

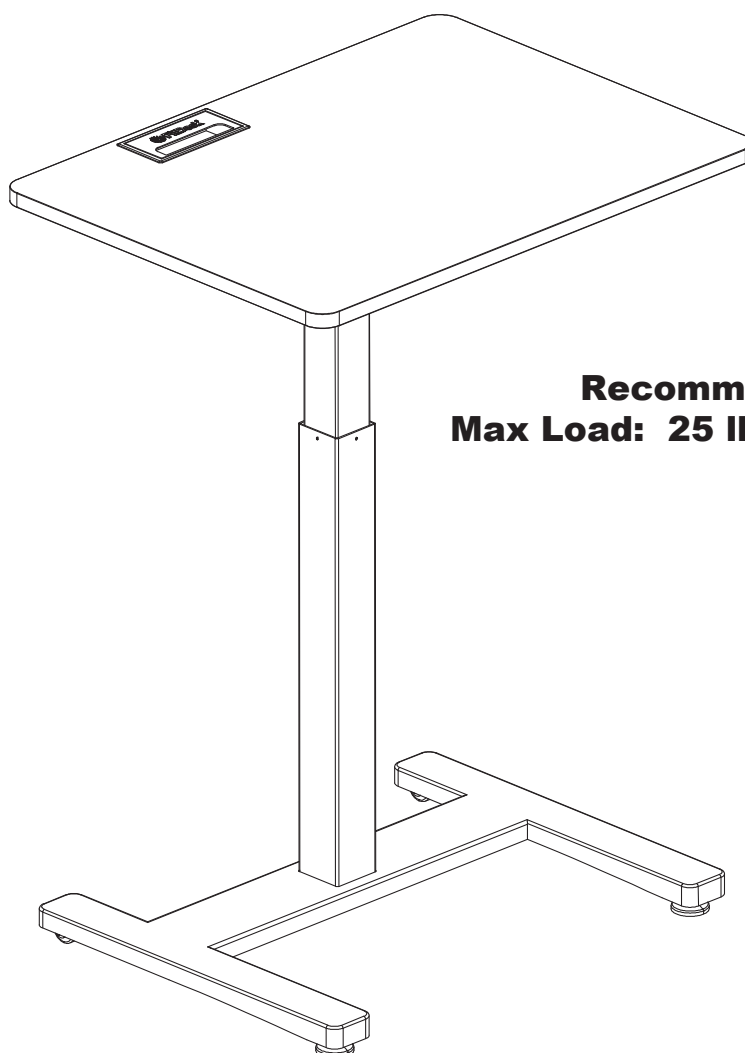

Where Health and Productivity Converge

Sit-To-Stand Desk

Owner's Manual



**Recommended
Max Load: 25 lbs. (11.3 kgs.)**

**VISIT OUR WEBSITE: WWW.THEFITDESK.COM
OR CALL US AT 1-336-423-5029 MONDAY - FRIDAY 9 A.M. - 5 P.M. EST**

DISTRIBUTED BY FD PRODUCTS LLC.
1161 SOUTH PARK DRIVE, KERNERSVILLE NC 27284

IMPORTANT: READ THE OWNER'S MANUAL BEFORE ASSEMBLING



TABLE OF CONTENTS

Introduction.....	1	Assembly.....	5
Safety Warnings / Maintenance.....	2	Operational Instructions.....	7
Customer Support.....	3	Warranty.....	8
Tools / Hardware / Parts.....	4		

INTRODUCTION

Congratulations on taking a **STAND** for your well-being by purchasing a **FitDesk® Sit-to-Stand Desk!**

We know that your chair will still be a part of your day, but we are confident that your new **Sit-to-Stand Desk** will give you a healthy alternative to inactive sitting.

Please check out some of our other health and productivity products @ www.thefitdesk.com

Weight of Sit Stand Desk: 48.1 lbs.

Recommended Max Load: 25 lbs. (11.3 kgs.)

Foot Print Size
30.7” Wide x 22.8” Deep x Min. 29.4” / Max. 47.9” High

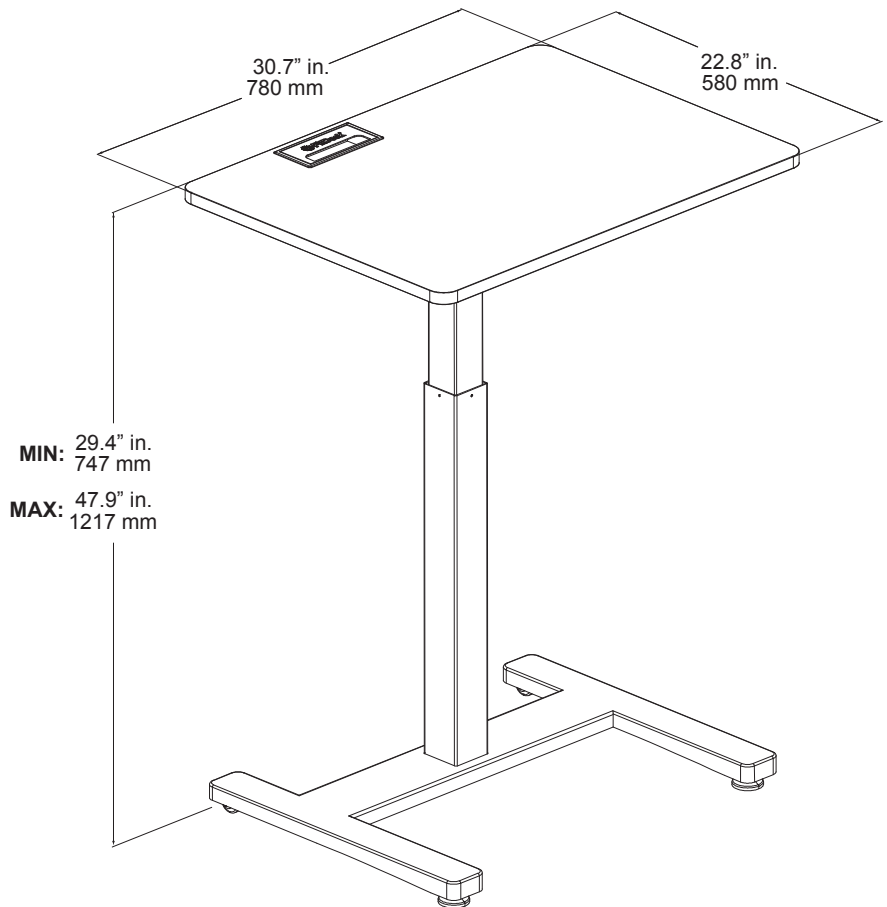

SAFETY WARNINGS - URGENT PLEASE READ THIS SECTION

WE WANT YOU TO SAFELY USE THIS PRODUCT

1. Read the entire manual before assembling and using this equipment. Safe use can only be achieved if the equipment is assembled, maintained and used properly. All users of the equipment must be informed of all warnings and precautions.
2. **CAUTION!** Do not exceed the Maximum Listed Weight Capacity of 25 lbs. (11.3 kgs). Serious Injury or Property Damage may occur.
3. **WARNING!** Make sure no obstacles are in the desk's path. Make sure the desktop is not touching any walls. Make sure all cords are appropriate length to accommodate the change in height.
4. Do not sit or stand on the desk frame. Do not crawl or lie under the desk frame.
5. Do not place any objects taller than 20" underneath the desk.
6. Do not attempt to raise or lower the desk with any item on the desk. Remove all items before raising or lowering.
7. Do not attempt to move the desk with any items on the desk. Remove all items before moving the desk.
8. Do not use for holding televisions or microwave ovens.
9. Keep young children and pets away from equipment.
10. Inspect and tighten all parts often. Replace any worn parts immediately. Do not use the equipment until the problem has been resolved.
11. If you find any defective components while assembling or checking the equipment, stop immediately.

WARNING! This height adjustable desk is designed for use in dry work areas only. The desk height is adjustable so that it can be positioned at the most ergonomically suitable height. Any other use is at user's risk.

MAINTENANCE

The integrity of the **FitDesk® Sit-To-Stand Desk** can only be maintained when it is regularly inspected for damage and wear. Special attention should be given to the following.

HARDWARE: Verify that all bolts are present and properly tightened.

TIP: Inspect Allen Bolts from time to time. **NOTE:** Do not overtighten Allen Bolts.

LUBRICATION: Periodically add lubrication for smooth operation.

NOTE: This equipment is suitable for home, school and office use only. Do not use in commercial or rental settings. This item was not intended or designed for use in commercial or public places.



NEED HELP?

CONTACT US FIRST

1-336- 423-5029

MONDAY - FRIDAY 9 A.M. - 5 P.M. EST

EASY TO USE CUSTOMER TICKETING

Step 1: www.thefitdesk.com

Step 2: “Support”

Step 3: “Submit A Support Ticket”

customerservice@thefitdesk.com

FOR FASTEST POSSIBLE SERVICE PLEASE HAVE AVAILABLE

Model # (refer to this manual) - Serial # (located on Where is this located?)

WWW.THEFITDESK.COM

TOOLS

Estimated Assembly Time : 10 minutes

AA



AA

AA. (1) 4mm Allen Wrench

BB



BB

BB. (1) 5mm Allen Wrench

Each FitDesk® Sit To Stand Desk comes equipped with two Allen Wrenches (**AA**) (**BB**).

HARDWARE

Note: Hardware and Tools not shown to actual size.

CC

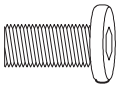

CC. (2) M6 x 12 Allen Bolt

DD



DD. (4) M6 x 30 Allen Bolt

EE

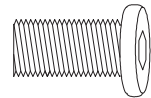

EE. (4) M8 x 20 Allen Bolt

PARTS

A

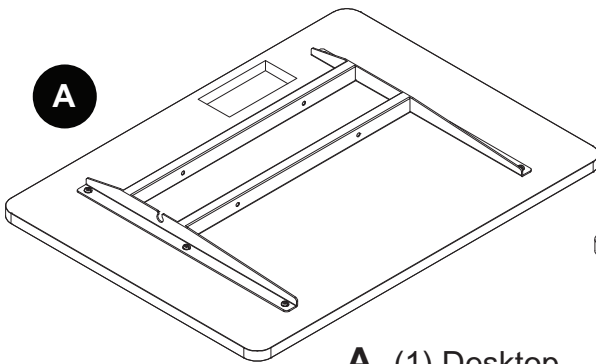

A. (1) Desktop

B

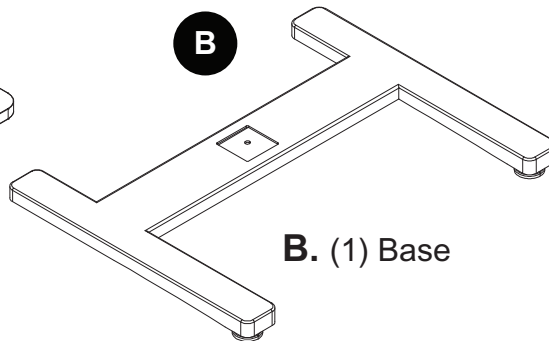

B. (1) Base

C

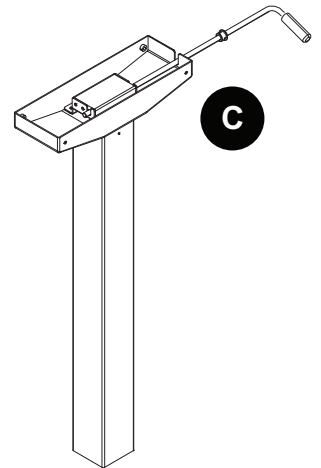

C. (1) Post

D

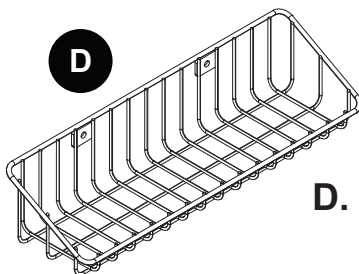

D. (1) Basket

E

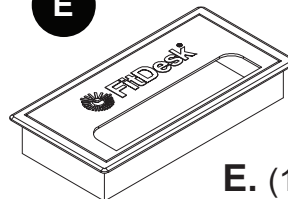

E. (1) Cable Management Box

NOTE: If Parts or hardware are missing contact customer service immediately.

ASSEMBLY

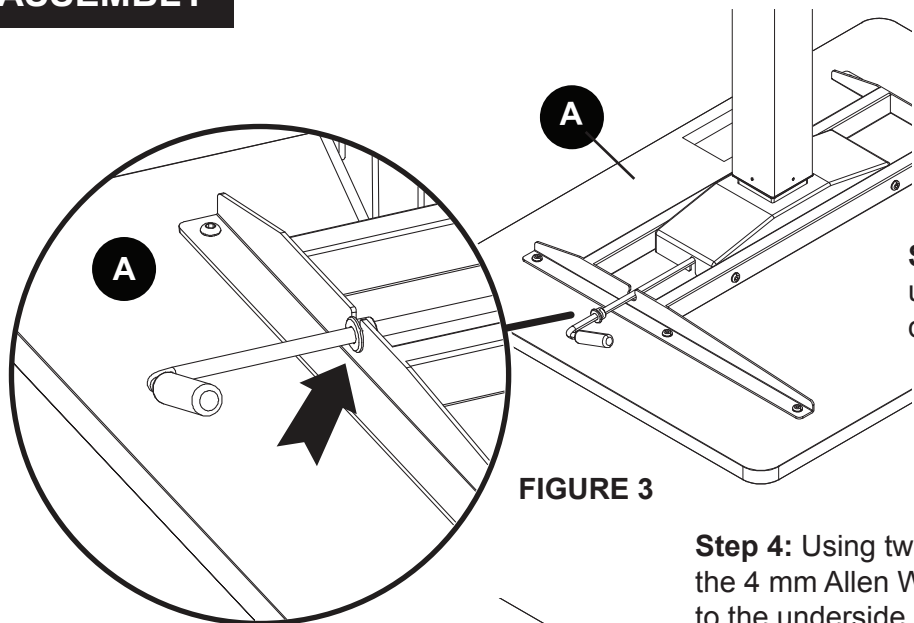

Step 3: While the Desktop (A) is still upside down, slide the plastic ring down, insert into place. **Figure 3**

Step 4: Using two M6 x 12 Allen Screws (CC) and the 4 mm Allen Wrench (AA) fasten the Basket (D) to the underside of the Desktop (A). **Figure 4**

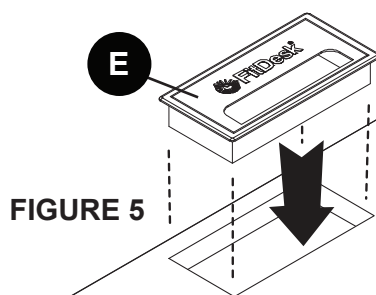
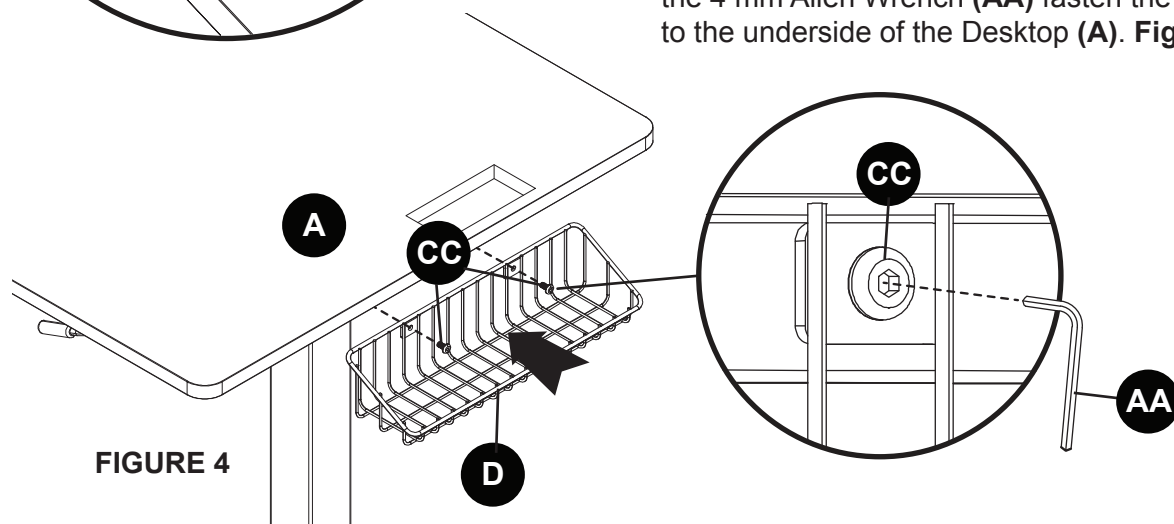

Step 5: Insert the Cable Management Box (E) into the Desktop (A). **Figure 5**

Your FitDesk® Model 2050 Sit To Stand Desk is now ready to use.



OPERATIONAL INSTRUCTIONS

NOTE: Before operating please read carefully

HEIGHT ADJUSTMENT

Step 1: To adjust the height of the Desktop (A) push handle up and hold.

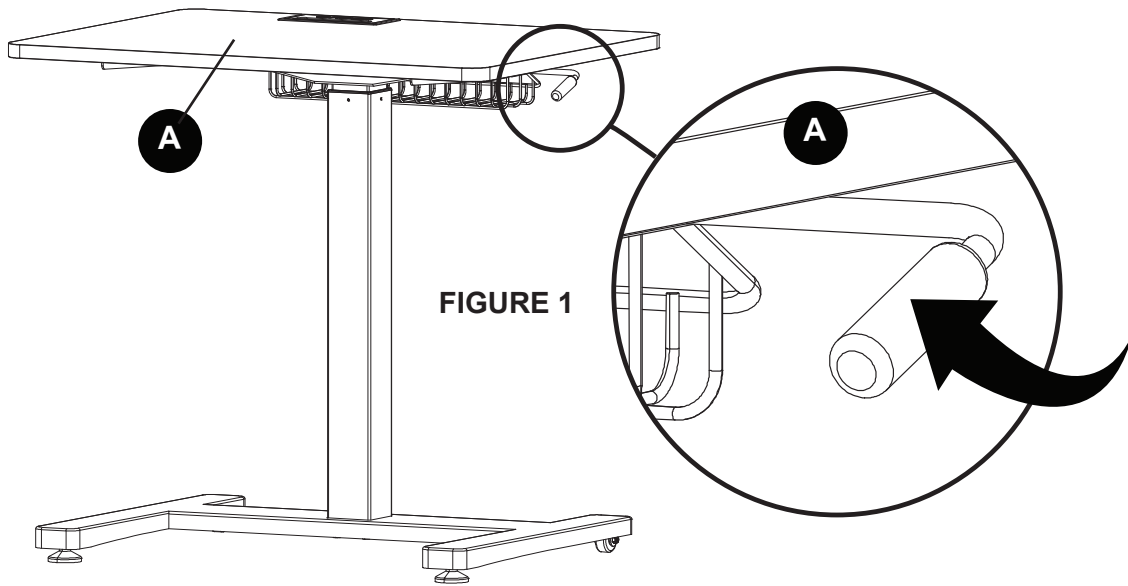

Step 2: Using both hands push down on the Desktop (A) to a desired height. Figure 2

Step 3: Using the same motion lift up the Desktop (A). Figure 3

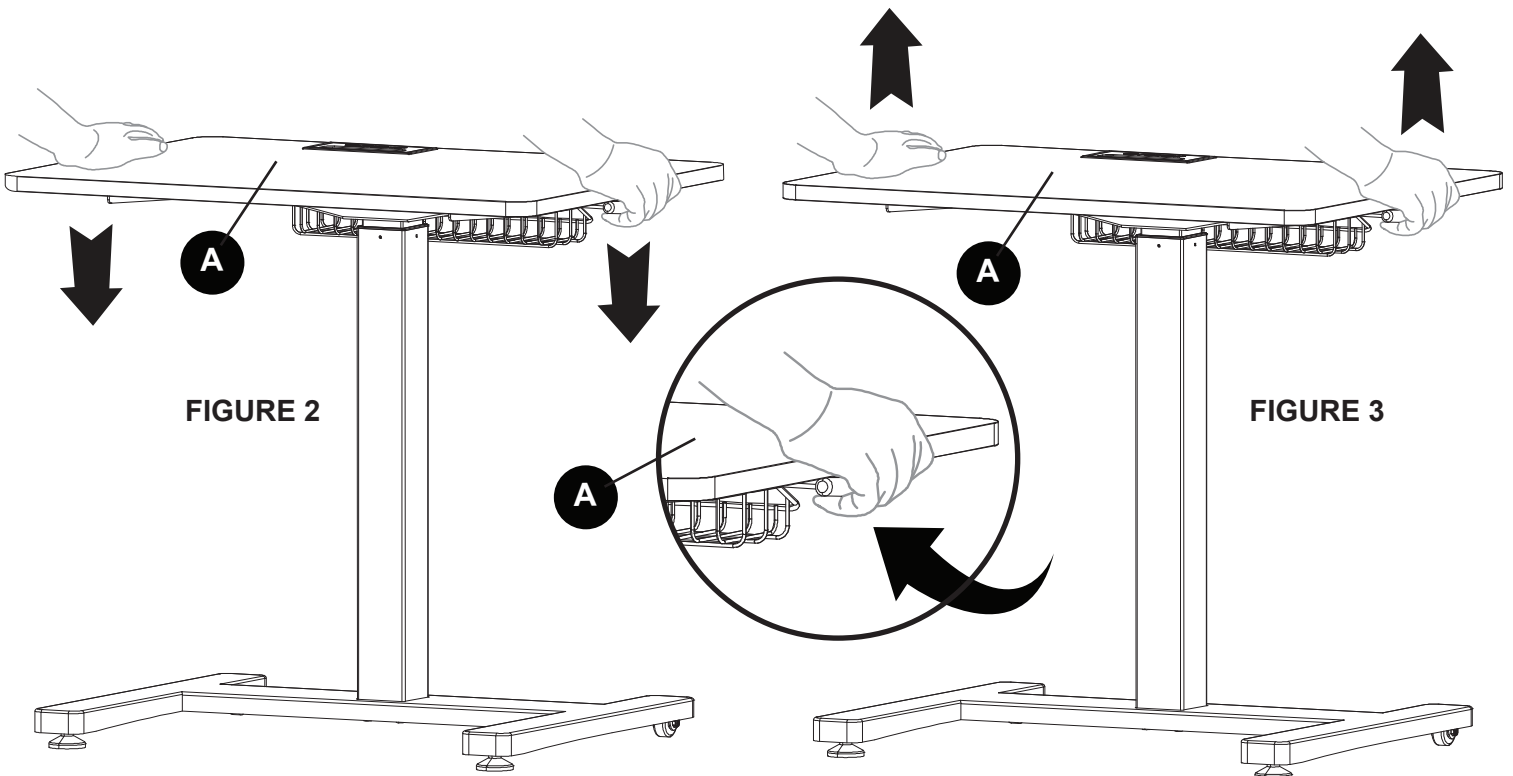

WARRANTY

This limited warranty is applicable to each original end-customer (hereinafter “Customer”) purchasing the **FitDesk®** Model: 2050 Sit-To-Stand Desk consisting of the structural metal frame (hereinafter the “Structural Frame”) and various other non-frame components (hereinafter the “Non-Frame Parts”) sold by FD Products, LLC (hereinafter “Company”) for Customer’s own use and not for resale. The Structural Frame and Non-Frame Parts are collectively referred to herein as the “Products”.

1. LIMITED WARRANTY; EXCLUSIVE REMEDIES:

1.1. **LIMITED WARRANTY ON PRODUCTS:** Company warrants solely to the original Customer that (a) the Structural Frame will be free from defects in materials and workmanship under normal use for a period of Five (5) YEARS from the date of original retail purchase, and (b) the Non-Frame Parts, will be free from defects in materials and workmanship under normal use for a period of Five (5) YEARS from the date of original retail purchase. Notwithstanding the foregoing, the colors and finishes of the Products may vary within a reasonable scope due to unavoidable color variations in different production batches, and such variations shall not constitute a material defect. This limited warranty is limited solely to the original Customer with proof of purchase and is not transferable.

1.2. **THE WARRANTY:** During a covered Product’s limited warranty period, Company will, at Company’s sole option and discretion, (1) repair the defective component or product without charge or (2) replace the defective component or product without charge.

1.3. The foregoing limited warranty is subject to the Customer’s proper storage, transportation, handling and use of the Products as the same are defined within Company’s then-current published guides and instructions for use and care. The limited warranty does not include defects due to normal wear and tear, abuse or misuse, mishandling, neglect, accident, fire, lightning, sunlight or other natural hazard, delivery or transportation damage, failure to follow applicable directions or instructions, or improper or inadequate cleaning, maintenance, care, repairs, modifications, or use beyond a Product’s intended use.

1.4. **LIMITED WARRANTY CLAIMS PROCEDURE:** To obtain performance under this limited warranty, Customer shall notify Company in writing (to FD Products, LLC, 1161 South Part Drive, Kernersville, NC 27284, Attn: Customer Service / Warranty Department), by email (to customerservice@thefitdesk.com), or by telephone (to (336) 423-5029) with a full description of the defect that is covered by warranty and a copy of the dated proof of purchase of the applicable product.

- Company shall review each such claim and issue Customer a return merchandise authorization (“RMA”) in the event that the described defect or condition merits warranty review as determined by Company. Customers who have been issued a RMA shall, at Company’s election, return the covered item to the same physical address listed above for reporting initial claims. Company shall not accept any returned product without a RMA.

- Upon receipt, Company will evaluate the returned product(s) to determine if there is a warranty claim and, if so, how Company wishes to remedy the same. During a covered product’s respective limited warranty period, Company will, at Company’s sole and absolute option and discretion, (1) repair the defective component or product without charge or (2) replace the defective component or product without charge. Refunds are not available pursuant to this limited warranty.

- Customer is solely responsible for transportation of the covered product(s) to the Company for evaluation (if applicable and requested by Company). In the event that Company determines that a claim under this limited warranty is justified, Company shall be responsible for transportation of the repaired, corrected, replaced or exchanged product back to Customer. Customer shall be solely responsible for the transportation of any product back to Customer if Company determines that a claim under this warranty is not justified.

- Any repaired, corrected, replaced or exchanged Products shall be subject to the Limited Warranty set forth to the duration of the original limited warranty period as set forth in Section 1.1. and not for any extended duration, following their repair, correction, replacement or exchange.

WARRANTY

1.1. IF A COMPANY PRODUCT DOES NOT CONFORM TO THESE LIMITED WARRANTIES, THE PURCHASER'S SOLE AND EXCLUSIVE REMEDY IS, AT COMPANY'S SOLE AND EXCLUSIVE OPTION, THE (1) REPAIR OF ANY DEFECTIVE PRODUCT OR COMPONENT PART OR (2) REPLACEMENT OF ANY DEFECTIVE PRODUCT OR COMPONENT PART. THE LIMITED WARRANTY AND REMEDIES SET FORTH ABOVE ARE EXCLUSIVE AND MADE IN LIEU OF ALL OTHER WARRANTIES, REMEDIES, RIGHTS OR CONDITIONS, WHETHER ORAL OR WRITTEN, EXPRESS OR IMPLIED, EITHER IN FACT OR BY OPERATION OF LAW, STATUTORY OR OTHERWISE, INCLUDING THE IMPLIED WARRANTIES OF MERCHANTABILITY AND FITNESS FOR A PARTICULAR PURPOSE. COMPANY SPECIFICALLY DISCLAIMS, WITHOUT LIMITATION, ANY AND ALL OTHER WARRANTIES, EXPRESS OR IMPLIED, OF ANY KIND. IF COMPANY CANNOT LAWFULLY DISCLAIM IMPLIED WARRANTIES UNDER THIS LIMITED WARRANTY, ALL SUCH WARRANTIES, INCLUDING THE IMPLIED WARRANTIES OF MERCHANTABILITY AND FITNESS FOR A PARTICULAR PURPOSE, ARE LIMITED IN DURATION TO THE DURATION OF THIS LIMITED WARRANTY. The Company does not assume or authorize any person to assume for them any other liability in connection with the Products.

2. EXCLUSION AND LIMITATION OF LIABILITY:

IN NO EVENT, WHETHER BASED ON CONTRACT OR TORT OR OTHER LEGAL THEORY, SHALL COMPANY BE LIABLE FOR ANY INDIRECT, INCIDENTAL, PUNITIVE, SPECIAL OR CONSEQUENTIAL DAMAGES, INCLUDING BUT NOT LIMITED TO, DAMAGES TO OTHER PROPERTY, INCONVENIENCE, DAMAGES FOR LOSS OF PROFITS, REVENUE, GOODWILL OR USE, INCURRED BY CUSTOMER OR ANY THIRD PARTY, WHETHER IN AN ACTION IN CONTRACT, TORT, STRICT LIABILITY, OR IMPOSED BY STATUTE, OR OTHERWISE, EVEN IF ADVISED OF THE POSSIBILITY OF SUCH DAMAGES. Some states do not allow the exclusion or limitation of incidental or consequential damages or exclusions or limitations on the duration of implied warranties or conditions, so the above limitations or exclusions may not apply to Customer. In jurisdictions that limit the scope of or preclude limitations or exclusion of remedies or damages, or of liability, such as liability for gross negligence or willful misconduct or do not allow implied warranties to be excluded, the limitation or exclusion of warranties, remedies, damages or liability set forth above are intended to apply to the maximum extent permitted by applicable law. This limited warranty gives the Customer specific legal rights, and the Customer may also have other rights that vary by state, country or other jurisdiction.

3. SEVERABILITY:

If any provision of this limited warranty is held to be illegal, invalid or otherwise unenforceable, such provision will be enforced to the extent possible consistent with its stated intention, or, if incapable of such enforcement, will be deemed to be severed and deleted from this limited warranty, while the remainder of the terms of this limited warranty will continue in full force and effect.

4. DISPUTE RESOLUTION:

This FitDesk Limited Warranty shall be governed by and construed in accordance with the laws of the State of North Carolina, without regard to its principles of conflicts of law. The parties acknowledge the exclusive jurisdiction of the federal and state courts of the State of North Carolina. Any claims or disputes under this FitDesk Limited Warranty shall be heard exclusively in any state or federal courts sitting in Guilford County, North Carolina, and both parties expressly consent to the personal jurisdiction and venue of the North Carolina state and federal courts for such actions.





Where Health and Productivity Converge



[facebook.com / Fitdesk](https://facebook.com/Fitdesk)

FitDesk® is a registered trademark of FD Products LLC. - All Rights Reserved 2016

Updated 12/5/2016