

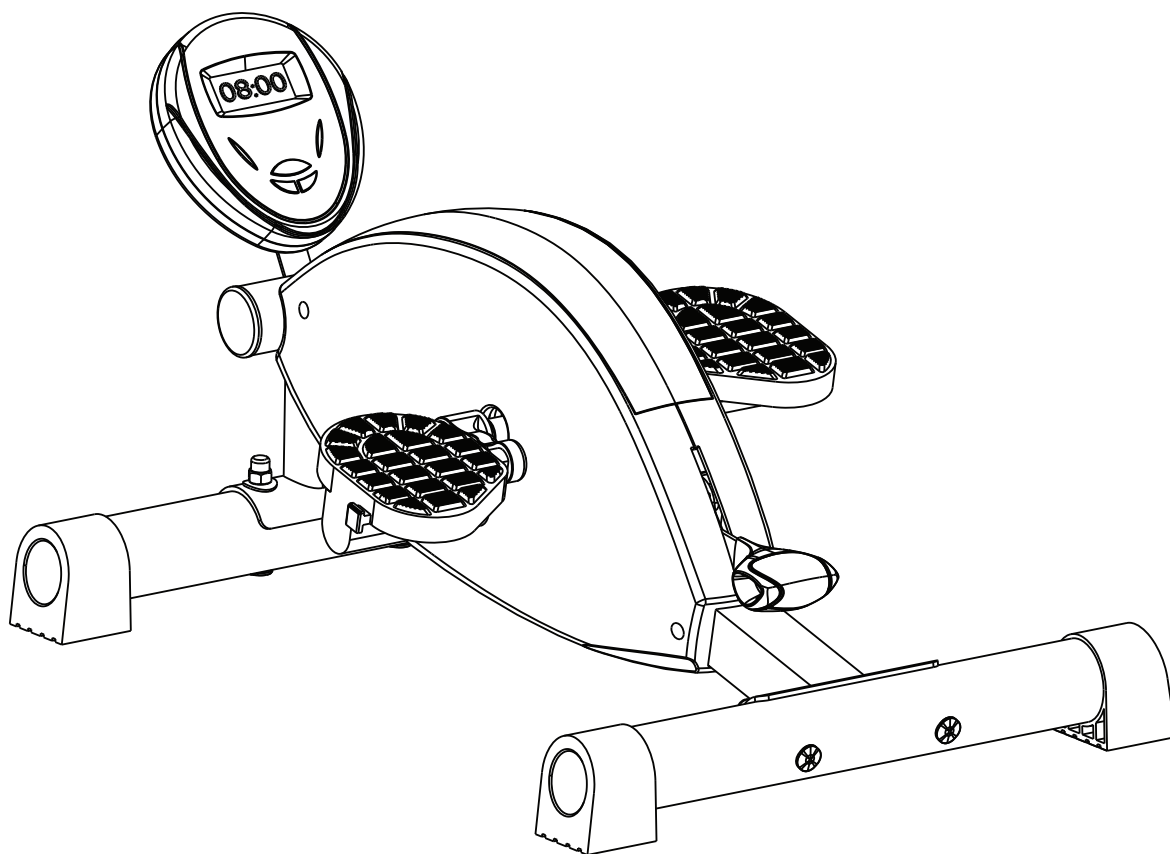

Where Health and Productivity Converge

Under Desk Cycle Owner's Manual



VISIT OUR WEBSITE: WWW.THEFITDESK.COM
OR CALL US AT 1-855-713-8887 MONDAY - FRIDAY 9 A.M. - 5 P.M. EST

DISTRIBUTED BY FD PRODUCTS LLC.
1161 SOUTH PARK DRIVE, KERNERSVILLE NC 27284

IMPORTANT: READ THE OWNER'S MANUAL BEFORE ASSEMBLING

TABLE OF CONTENTS

Introduction.....	2	Operational Instructions.....	10
Safety Warnings / Warnings and Labels.....	3	Maintenance and Troubleshooting	
Customer Service.....	4	Warranty.....	11
Tools / Hardware.....	5	Complete Parts List.....	13
Parts.....	6	Optional Products.....	14
Assembly.....	7		
Meter / Operation.....	9		

INTRODUCTION

Thank you for choosing **FitDesk®**. We hope your new **FitDesk® Under Desk Cycle** becomes a regular part of your daily routine and we wish you good health and increased wellness as you use this product to infuse activity into parts of your day.

Before you start assembling your new FitDesk® please take a moment to make sure all tools, hardware and parts are included.

Please read all safety precautions before using this product.

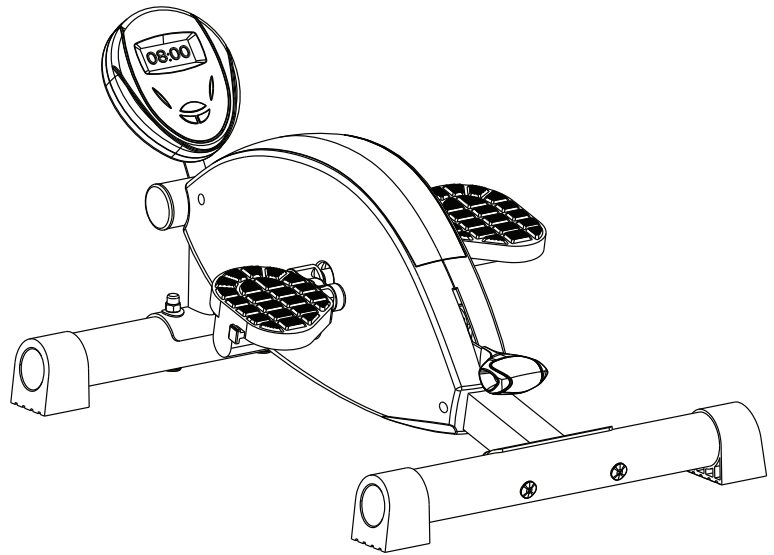

Weight of UDE: 21.94 lbs.

Foot Print in ASSEMBLED position
27.95" wide x 16.93" long x 11.80" high



SAFETY WARNINGS - URGENT PLEASE READ THIS SECTION

WE WANT YOU TO SAFELY USE THIS PRODUCT

1. Read the entire manual before assembling and using the equipment. Safe use can only be achieved if the equipment is assembled, maintained and used properly. All users of the equipment must be informed of all warnings and precautions.
2. Before starting or using this equipment you should consult your doctor to determine if you have any health conditions that could create a risk to your health and safety, or prevent you from using the equipment properly.
3. Be aware of your body's signals. Incorrect or excessive exercise can damage your health. Stop exercising if you experience any of the following symptoms: Pain, tightness in you chest, irregular heartbeat, extreme shortness of breath, feeling light headed, dizzy or nauseous. If you do experience any of these conditions consult your physician.
4. Warm-up stretching is recommended before exercise.
5. Read and follow all warning stickers on the **FitDesk®**.
6. Keep pets and young children away from the equipment.
Caution: Fingers can get pinched when picking up the **FitDesk®** UDC.
Caution: Pedal platforms can swing over.
7. Use the equipment on a solid, level surface with a protective cover for your floor or carpet.
8. If using included desk stand for meter, keep wires from getting tangled while pedaling.
9. Inspect and tighten all parts often. Replace any worn parts immediately.
10. If you find any defective components while assembling or checking the equipment or if you hear any unusual noises coming from the equipment during use, stop immediately. Do not use the equipment until the problem has been resolved.
11. Do not stand while pedaling. **For light exercise use only.**
Note: The equipment is suitable for home and office use only. Do not use in commercial or rental settings.

WARNINGS AND LABELS

NOTE: Read all warning stickers before operating this product.

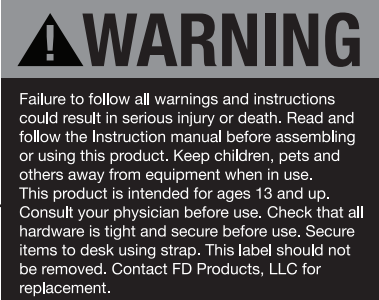
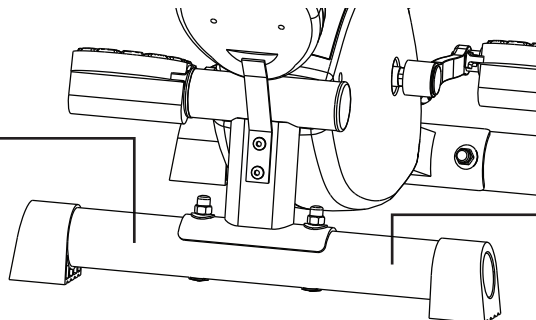

CUSTOMER SERVICE QUESTIONS



NEED HELP?

CONTACT US FIRST

1-855-713-8887

MONDAY - FRIDAY 9 A.M. - 5 P.M. EST

EASY TO USE CUSTOMER TICKETING

Step 1: www.thefitdesk.com

Step 2: “Support”

Step 3: “Submit A Support Ticket”

customerservice@thefitdesk.com

FOR FASTEST POSSIBLE SERVICE PLEASE HAVE AVAILABLE

Model # 3030 - Serial # (located on the front stabilizer)

WWW.THEFITDESK.COM

TOOLS

Estimated Assembly Time : 10 minutes

AA

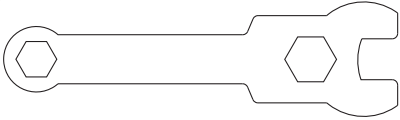

AA. Wrench
(Supplied)

BB



BB. 6mm Allen Key
(Supplied)

Each **FitDesk®** Under Desk Cycle comes equipped with one Wrench and a 6mm Allen Wrench.

HARDWARE

Note: Hardware and Tools not shown to actual size.

CC

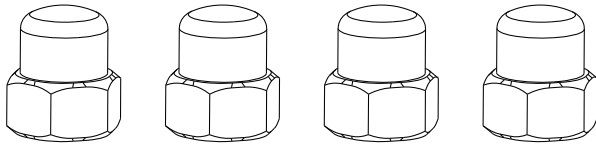

CC. (4) M8 Cap Nuts

DD



DD. (4) M8 Washers

EE

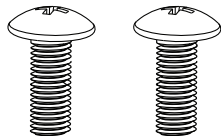

EE. (2) M5 Cross Bolts

NOTE: If parts or hardware are missing contact customer service immediately.

Please do not discard your packaging until your entire **FitDesk®** is fully assembled. Some parts are purposely packaged in cardboard or Styrofoam and can mistakenly be thrown away with the packaging.

PARTS

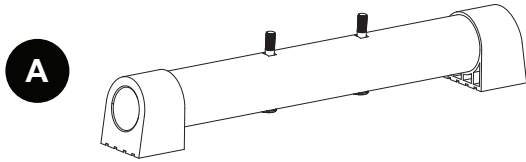

A. Front Stabilizer

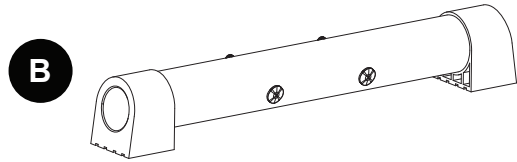

B. Rear Stabilizer

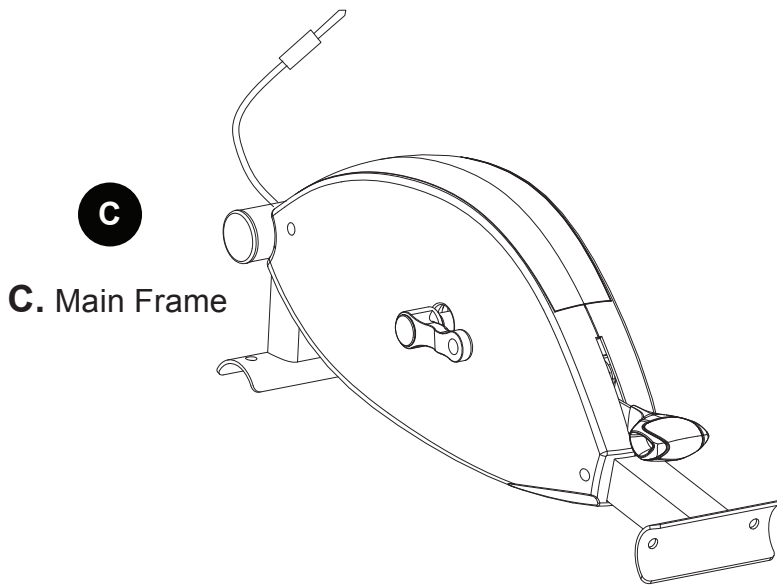

C. Main Frame



D. Left Pedal

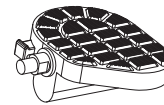

E. Right Pedal

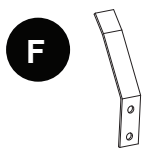

F. Meter Support

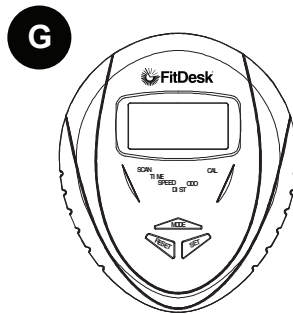

G. Meter

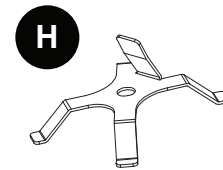

H. Meter Stand

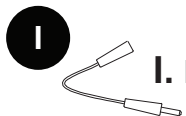

I. Long Meter Cord



ASSEMBLY

FIGURE 1

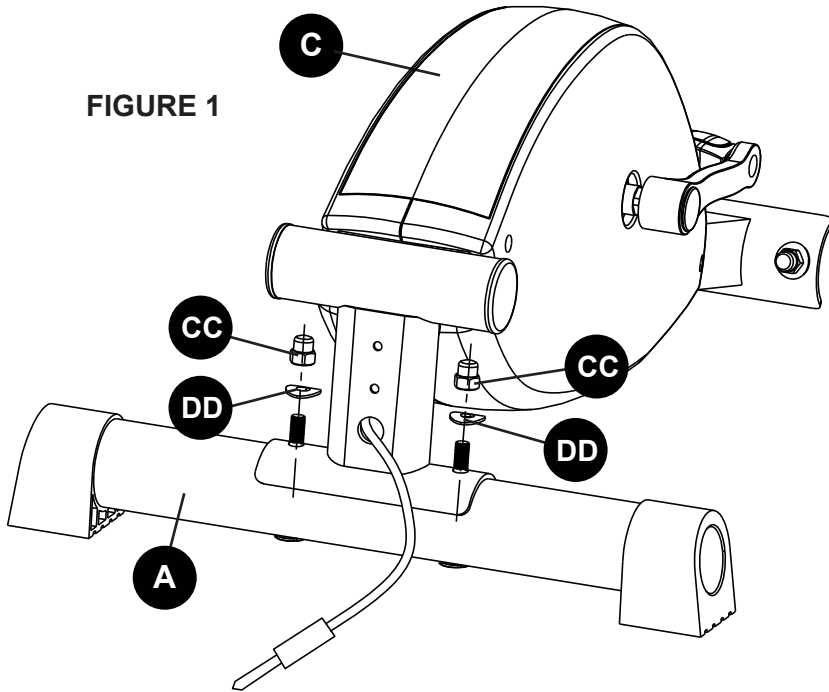

Step 1. Install the Front Stabilizer (A) to the UDC Main Frame (C) using the supplied Wrench (AA) Attach and tighten the two M8 Cap Nuts (CC) and M8 Washers (DD). Be sure to tighten securely. **Figure 1**

FIGURE 2

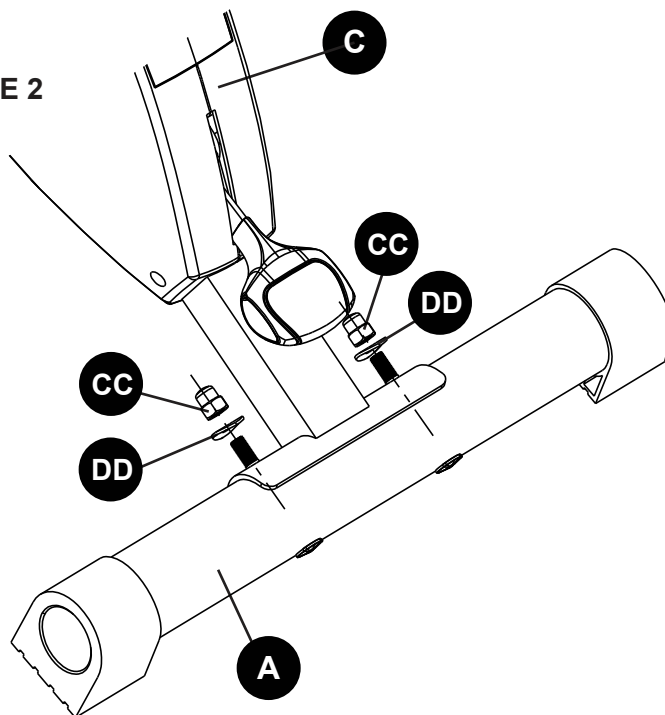

Step 2. Install the Rear Stabilizer (B) to the UDC Main Frame (C) using the supplied Wrench (AA) Attach and tighten the two M8 Cap Nuts (CC) and M8 Washers (DD). Be sure to tighten securely. **Figure 2**

ASSEMBLY

FIGURE 3

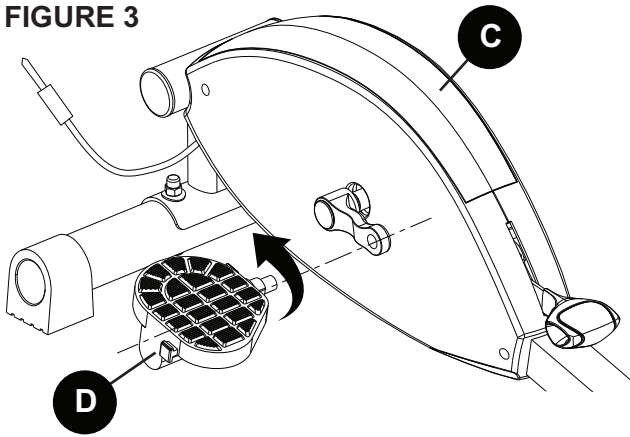

Step 3: Using the supplied Wrench (AA) attach the Left Pedal (D) to the Crank Arm attached to the Main Frame (C) by tightening the Pedal counter clockwise.

Note: Left Pedal (D) is reverse treaded. **Figure 3**

Step 4: Using the supplied Wrench (AA) attach the Right Pedal (E) to the Crank Arm attached to the Main Frame (C) by tightening the Pedal clockwise. **Figure 4**

WARNING: Make sure the pedals are threaded properly to ensure you do not damage the threads.

Note: The Pedals must be made extra tight. Use the included Wrench or a 15mm wrench to finish tightening.

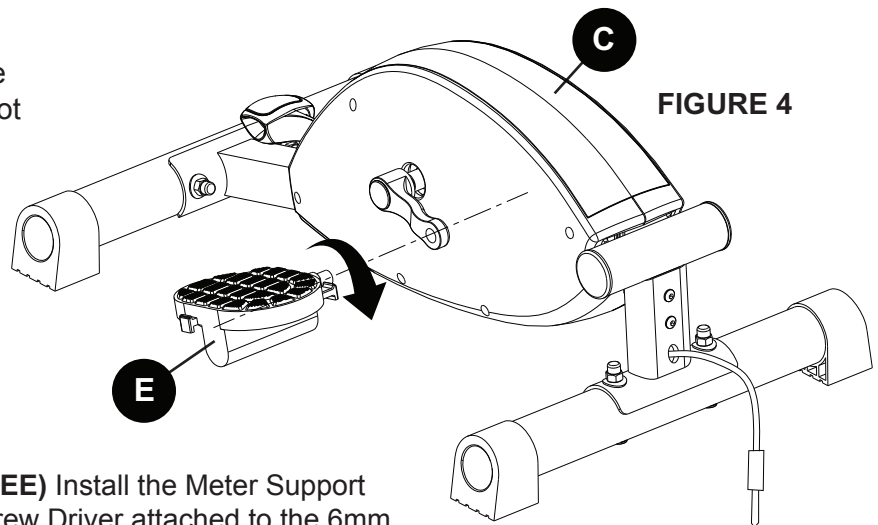

FIGURE 4

Step 5: Using the two M5 Cross Bolts (EE) Install the Meter Support (F) to the Main Frame (C) using the Screw Driver attached to the 6mm Allen Key (BB). **Figure 5**

Step 6: Slide the Meter (G) onto the Meter Support (F). **Figure 6**

Step 7: Plug the Meter Wire into the back of the Meter (G). (**Figure 7**)

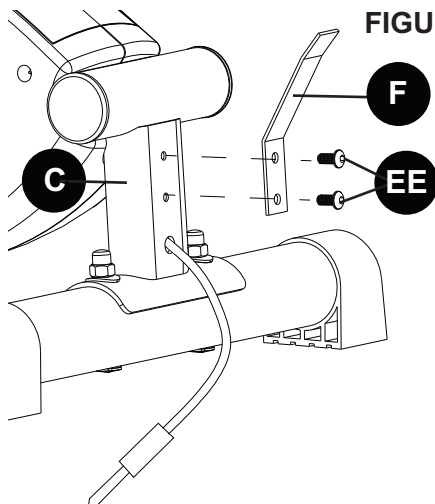

FIGURE 5

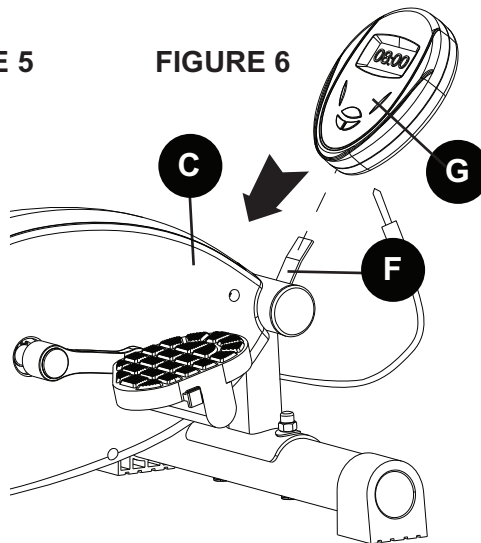

FIGURE 6

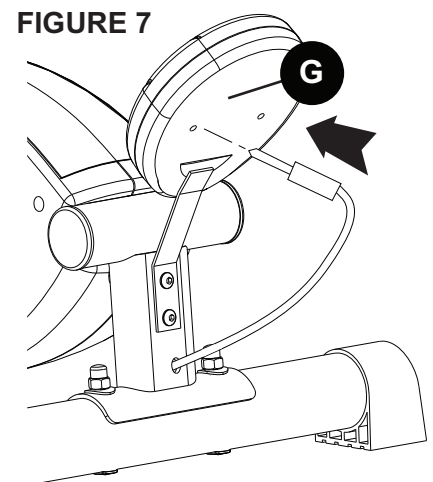
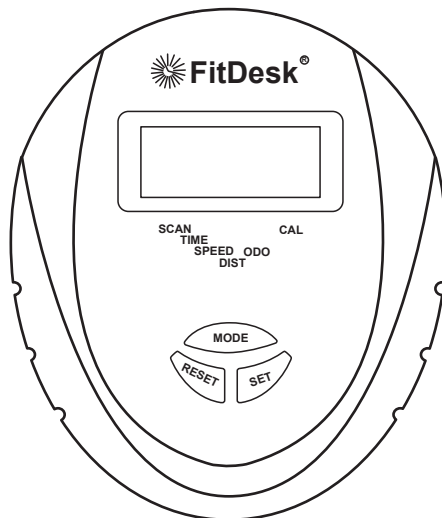
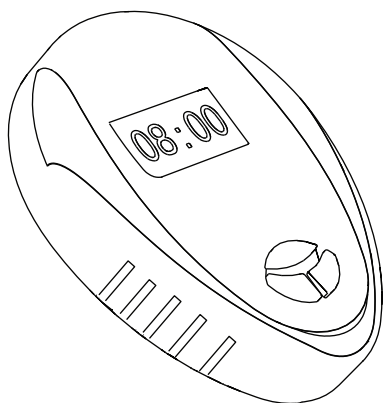

FIGURE 7

METER / OPERATION



INSTRUCTIONS:

1. Mode button advances the Meter.
 - a. Time in use
 - b. Speed - MPH
 - c. Distance - Miles or KM
 - d. Total distance on **FitDesk**[®] - ODO in Miles or KM.
 - e. Calories burned
2. Reset button allows for Meter to be reset for time. Distance and Calories Mode.
 - a. Stop pedaling then push reset to reset each Mode.
3. Scan will automatically start at each Mode.
 - a. To Stop Scan press mode button again.
 - b. Scan indicator is on screen when in Scan Mode.
4. Set button to count down feature. Hit the Mode button to stay on "Time," make sure you are not in Scan Mode. Hit "Set" until the desired count down time is displayed.

TROUBLESHOOTING:

1. Meter will turn on as soon as you start pedaling.
2. If Meter does NOT show zero even if you push the Mode Button.
 - a. Check to see that batteries are fresh and properly installed.
3. If zeros display when you press the Mode Button, But not when pedaling.
 - a. Check connection to Meter.

BATTERY INSTRUCTIONS

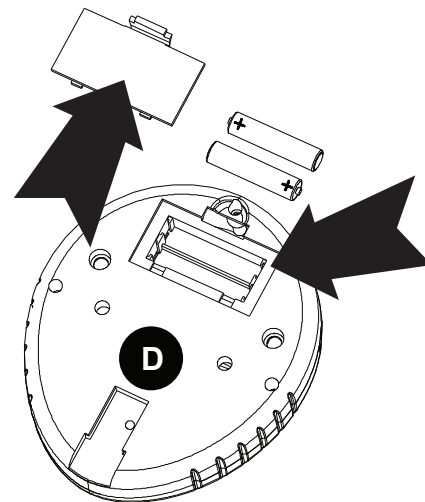

INSTALLING AND REPLACING **FitDesk**[®] METER BATTERIES:

The Meter (**D**) operates using two AAA batteries.

Batteries are included

Refer to the illustration to install or replace the batteries.

For Questions Contact:
1-855-713-8887

MONDAY - FRIDAY 9 A.M. - 5 P.M. EST



OPERATIONAL INSTRUCTIONS

NOTE: Before operating please read carefully

METER STAND

If you desire, use the supplied Long Meter Cord (I) and Meter Stand (H) to hold the Meter (G) on a desk to easily view your progress.

CAUTION: Keep Long Meter Cord (I) away from Pedals (D, E) when using UDC.

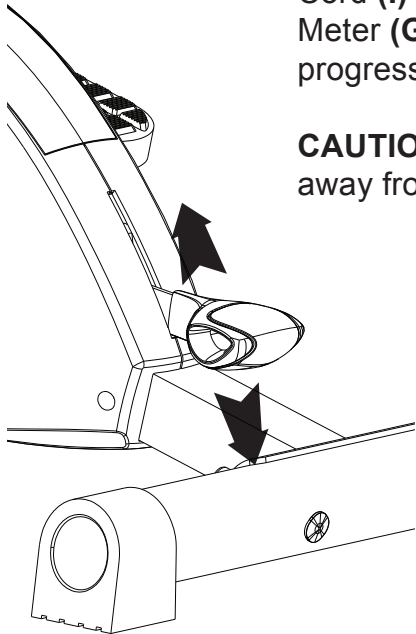

RESISTANCE LEVER

Move lever from 1-8 to change resistance. Start at the lowest resistance setting first.

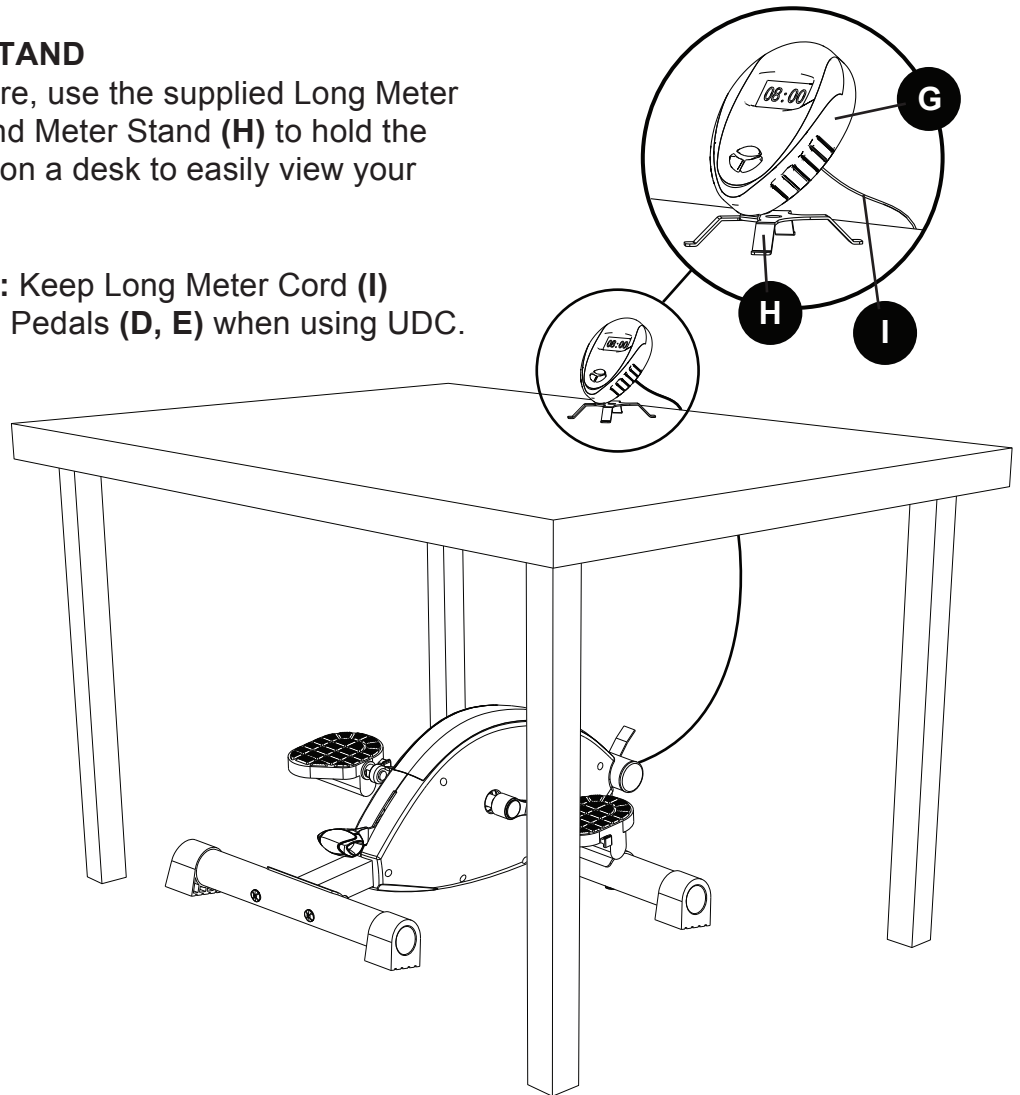

MAINTENANCE AND TROUBLESHOOTING

The integrity of the **FitDesk®** UDC 3030 can only be maintained when it is regularly examined for damage and wear. Special attention should be given to the following:

HARDWARE

Verify that all bolts are present and properly tightened.

NOTE: Inspect nuts, screws and knobs on a weekly basis.

WARRANTY

This limited warranty is applicable to each original end-customer (hereinafter “Customer”) purchasing the **FitDesk® Model: 3030** consisting of the structural metal frame (hereinafter the “Structural Frame”) and various other non-frame components (hereinafter the “Non-Frame Parts”) sold by FD Products, LLC (hereinafter “Company”) for Customer’s own use and not for resale. The Structural Frame and Non-Frame Parts are collectively referred to herein as the “Products”.

1. LIMITED WARRANTY; EXCLUSIVE REMEDIES:

1.1. **LIMITED WARRANTY ON PRODUCTS:** Company warrants solely to the original Customer that (a) the Structural Frame will be free from defects in materials and workmanship under normal use for a period of 180 days from the date of original retail purchase, Notwithstanding the foregoing, the colors and finishes of the Products may vary within a reasonable scope due to unavoidable color variations in different production batches, and such variations shall not constitute a material defect. This limited warranty is limited solely to the original Customer with proof of purchase and is not transferable.

1.2. **THE WARRANTY:** During a covered Product’s limited warranty period, Company will, at Company’s sole option and discretion, (1) repair the defective component or product without charge or (2) replace the defective component or product without charge.

1.3. The foregoing limited warranty is subject to the Customer’s proper storage, transportation, handling and use of the Products as the same are defined within Company’s then-current published guides and instructions for use and care. The limited warranty does not include defects due to normal wear and tear, abuse or misuse, mishandling, neglect, accident, fire, lightning, sunlight or other natural hazard, delivery or transportation damage, failure to follow applicable directions or instructions, or improper or inadequate cleaning, maintenance, care, repairs, modifications, or use beyond a Product’s intended use.

1.4. **LIMITED WARRANTY CLAIMS PROCEDURE:** To obtain performance under this limited warranty, Customer shall notify Company in writing (to FD Products, LLC, 1161 South Park Drive, Kernersville, NC 27284, Attn: Customer Service / Warranty Department), by email (to customerservice@thefitdesk.com), or by telephone (to (336) 423-5029) with a full description of the defect that is covered by warranty and a copy of the dated proof of purchase of the applicable product.

- Company shall review each such claim and issue Customer a return merchandise authorization (“RMA”) in the event that the described defect or condition merits warranty review as determined by Company. Customers who have been issued a RMA shall, at Company’s election, return the covered item to the same physical address listed above for reporting initial claims. Company shall not accept any returned product without a RMA.

- Upon receipt, Company will evaluate the returned product(s) to determine if there is a warranty claim and, if so, how Company wishes to remedy the same. During a covered product’s respective limited warranty period, Company will, at Company’s sole and absolute option and discretion, (1) repair the defective component or product without charge or (2) replace the defective component or product without charge. Refunds are not available pursuant to this limited warranty.

- Customer is solely responsible for transportation of the covered product(s) to the Company for evaluation (if applicable and requested by Company). In the event that Company determines that a claim under this limited warranty is justified, Company shall be responsible for transportation of the repaired, corrected, replaced or exchanged product back to Customer. Customer shall be solely responsible for the transportation of any product back to Customer if Company determines that a claim under this warranty is not justified.

- Any repaired, corrected, replaced or exchanged Products shall be subject to the Limited Warranty set forth to the duration of the original limited warranty period as set forth in Section 1.1. and not for any extended duration, following their repair, correction, replacement or exchange.

WARRANTY

1.1. IF A COMPANY PRODUCT DOES NOT CONFORM TO THESE LIMITED WARRANTIES, THE PURCHASER'S SOLE AND EXCLUSIVE REMEDY IS, AT COMPANY'S SOLE AND EXCLUSIVE OPTION, THE (1) REPAIR OF ANY DEFECTIVE PRODUCT OR COMPONENT PART OR (2) REPLACEMENT OF ANY DEFECTIVE PRODUCT OR COMPONENT PART. THE LIMITED WARRANTY AND REMEDIES SET FORTH ABOVE ARE EXCLUSIVE AND MADE IN LIEU OF ALL OTHER WARRANTIES, REMEDIES, RIGHTS OR CONDITIONS, WHETHER ORAL OR WRITTEN, EXPRESS OR IMPLIED, EITHER IN FACT OR BY OPERATION OF LAW, STATUTORY OR OTHERWISE, INCLUDING THE IMPLIED WARRANTIES OF MERCHANTABILITY AND FITNESS FOR A PARTICULAR PURPOSE. COMPANY SPECIFICALLY DISCLAIMS, WITHOUT LIMITATION, ANY AND ALL OTHER WARRANTIES, EXPRESS OR IMPLIED, OF ANY KIND. IF COMPANY CANNOT LAWFULLY DISCLAIM IMPLIED WARRANTIES UNDER THIS LIMITED WARRANTY, ALL SUCH WARRANTIES, INCLUDING THE IMPLIED WARRANTIES OF MERCHANTABILITY AND FITNESS FOR A PARTICULAR PURPOSE, ARE LIMITED IN DURATION TO THE DURATION OF THIS LIMITED WARRANTY. The Company does not assume or authorize any person to assume for them any other liability in connection with the Products.

2. EXCLUSION AND LIMITATION OF LIABILITY:

IN NO EVENT, WHETHER BASED ON CONTRACT OR TORT OR OTHER LEGAL THEORY, SHALL COMPANY BE LIABLE FOR ANY INDIRECT, INCIDENTAL, PUNITIVE, SPECIAL OR CONSEQUENTIAL DAMAGES, INCLUDING BUT NOT LIMITED TO, DAMAGES TO OTHER PROPERTY, INCONVENIENCE, DAMAGES FOR LOSS OF PROFITS, REVENUE, GOODWILL OR USE, INCURRED BY CUSTOMER OR ANY THIRD PARTY, WHETHER IN AN ACTION IN CONTRACT, TORT, STRICT LIABILITY, OR IMPOSED BY STATUTE, OR OTHERWISE, EVEN IF ADVISED OF THE POSSIBILITY OF SUCH DAMAGES. Some states do not allow the exclusion or limitation of incidental or consequential damages or exclusions or limitations on the duration of implied warranties or conditions, so the above limitations or exclusions may not apply to Customer. In jurisdictions that limit the scope of or preclude limitations or exclusion of remedies or damages, or of liability, such as liability for gross negligence or willful misconduct or do not allow implied warranties to be excluded, the limitation or exclusion of warranties, remedies, damages or liability set forth above are intended to apply to the maximum extent permitted by applicable law. This limited warranty gives the Customer specific legal rights, and the Customer may also have other rights that vary by state, country or other jurisdiction.

3. SEVERABILITY:

If any provision of this limited warranty is held to be illegal, invalid or otherwise unenforceable, such provision will be enforced to the extent possible consistent with its stated intention, or, if incapable of such enforcement, will be deemed to be severed and deleted from this limited warranty, while the remainder of the terms of this limited warranty will continue in full force and effect.

4. DISPUTE RESOLUTION:

This FitDesk Limited Warranty shall be governed by and construed in accordance with the laws of the State of North Carolina, without regard to its principles of conflicts of law. The parties acknowledge the exclusive jurisdiction of the federal and state courts of the State of North Carolina. Any claims or disputes under this FitDesk Limited Warranty shall be heard exclusively in any state or federal courts sitting in Guilford County, North Carolina, and both parties expressly consent to the personal jurisdiction and venue of the North Carolina state and federal courts for such actions.



COMPLETE PARTS LIST

DESCRIPTION:

QTY:

1. M8 Cap Nuts	4
2. M8 Washer	4
3. Rear Stabilizer	1
4. Main Frame	1
5. Left Pedal	1
6. Right Pedal	1
7. M5 Cross Bolts	2
8. Meter Support	1
9. Meter	1
10. Front Stabilizer	1
11. Meter Stand	1
12. Long Meter Cord	1

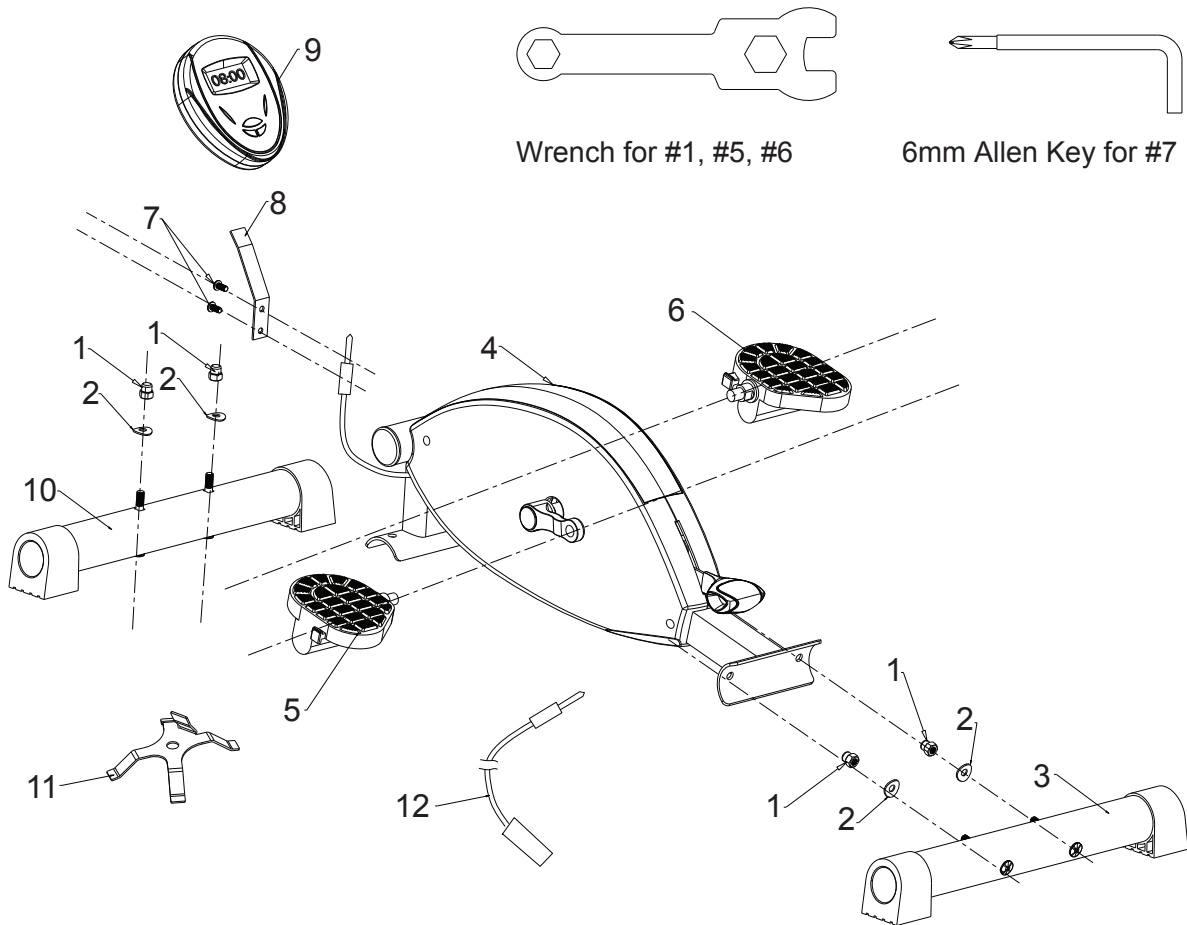

**For Questions Contact:
1-855- 713-8887**

MONDAY - FRIDAY 9 A.M. - 5 P.M. EST

OPTIONAL PRODUCTS

THE ORIGINAL

FitDesk® Model: 3.0

Weight of Bike: 48 lbs.

Recommended User Height Range
4'10" to 6'5" (147 cm to 199 cm)

Recommended Max User Weight
300lbs (136 kgs)

Foot Print in OPEN position
16" wide x 26" long x 45" high

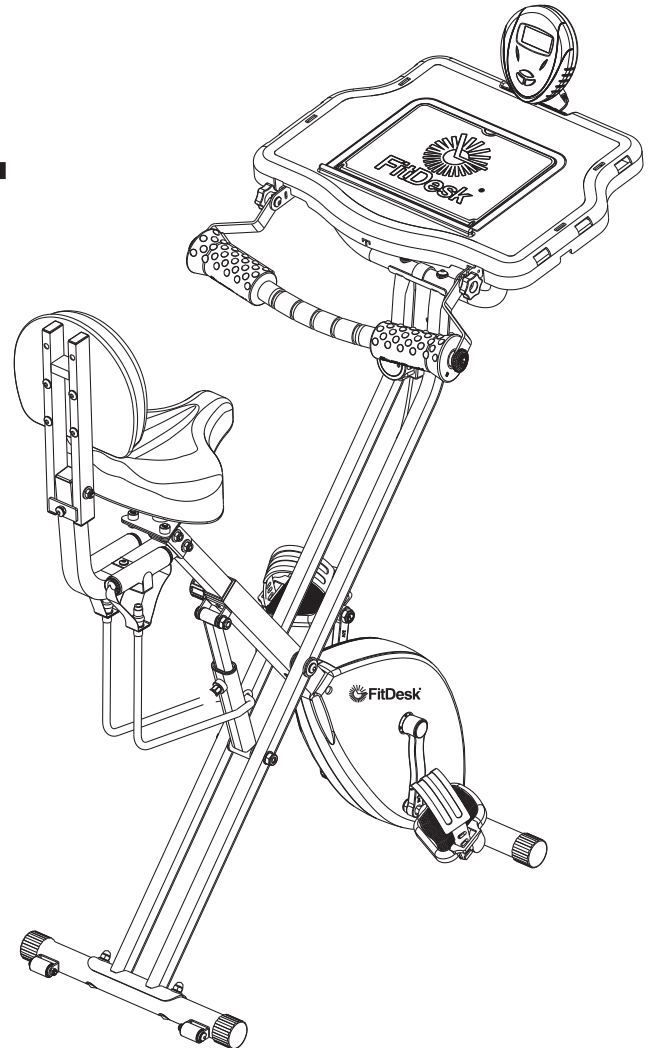
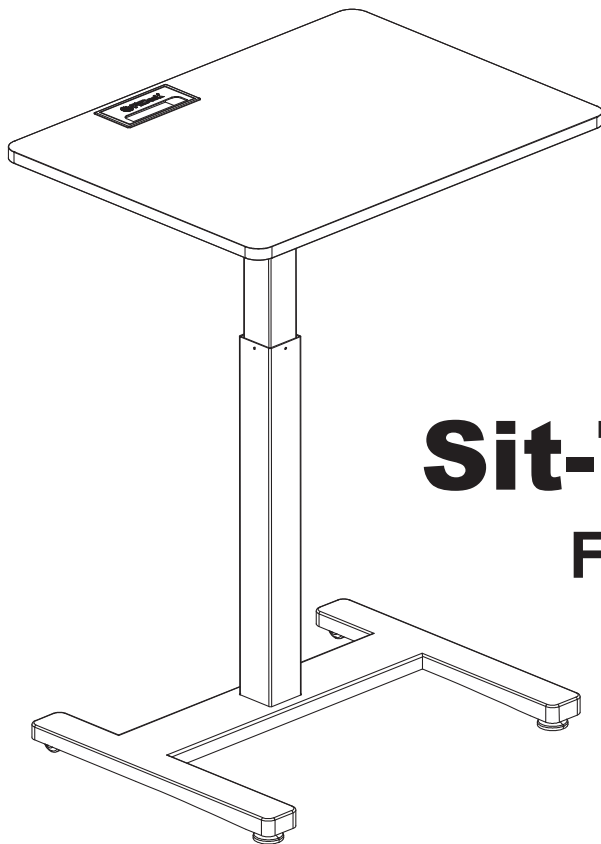

Sit-To-Stand Desk

FitDesk® Model: 2050

Recommended
Max Load: 25 lbs. (11.3 kgs.)

To buy other products go to our
Website @ www.thefitdesk.com





Where Health and Productivity Converge



[facebook.com / Fitdesk](https://facebook.com/Fitdesk)

FitDesk® is a registered trademark of FD Products LLC. - All Rights Reserved 2017

Updated 8/18/2017