

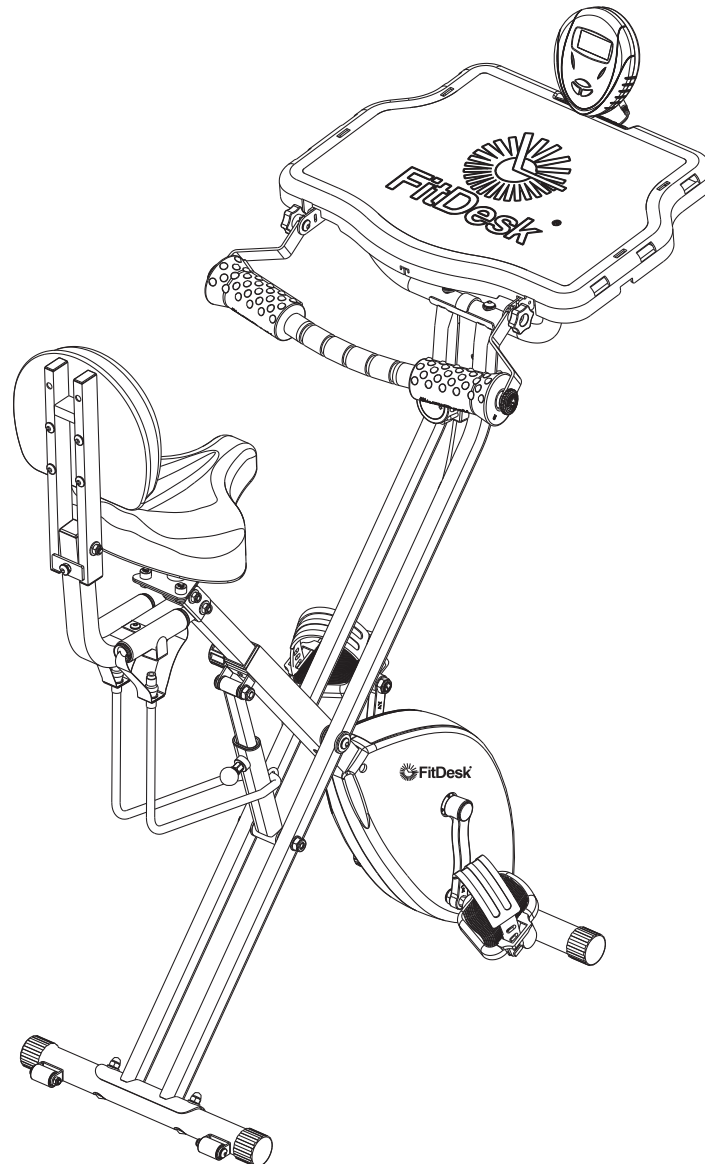

Where Health and Productivity Converge

Owner's Manual



VISIT OUR WEBSITE: WWW.THEFITDESK.COM
OR CALL US AT 1-855-713-8887 MONDAY - FRIDAY 9 A.M. - 5 P.M. EST

DISTRIBUTED BY FD PRODUCTS LLC.
1161 SOUTH PARK DRIVE, KERNERSVILLE NC 27284

IMPORTANT: READ THE OWNER'S MANUAL BEFORE ASSEMBLING

TABLE OF CONTENTS

Introduction.....	1	Operational Instructions.....	12
Safety Warnings.....	2	Meter.....	14
Customer Support.....	3	Set-Up / Storage.....	15
Tools / Hardware / Knobs.....	4	Maintenance and Troubleshooting.....	16
Parts / Desk Parts & Components.....	5	Warranty.....	17
BILT [®] / Assembly.....	6	Parts List.....	19
Assembly / Warnings and Labels.....	10	Exploded View.....	20
Warming Up.....	11	Optional Accessories.....	21

INTRODUCTION

Thank you for choosing **FitDesk**[®]. We hope your new **FitDesk**[®] Workstation becomes a regular part of your daily routine. And we wish you good health and increased wellness as you use the **FitDesk**[®] to infuse activity into parts of your day.

Before you start assembling your new **FitDesk**[®], please take a moment to download the **BILT**[™] Assemble Anything App. We have prepared an interactive 3-D assembly guide in full color to make assembling your **FitDesk**[®] as easy as possible.

All you have to do to get started is:

1. Download the **BILT**[™] App.
2. Search **FitDesk**[®]
3. Assemble your product with easy to understand 3-D instructions.

Whether using the **BILT**[™] App. or your paper manual, we encourage you to read this manual carefully before using your **FitDesk**[®].

Weight of Bike: 48 lbs.

**Recommended User Height Range
4'10" to 6'5" (147 cm to 199 cm)**

**Recommended Max User Weight
300lbs (136 kgs)**

**Foot Print in OPEN position
16" wide x 26" long x 45" high**

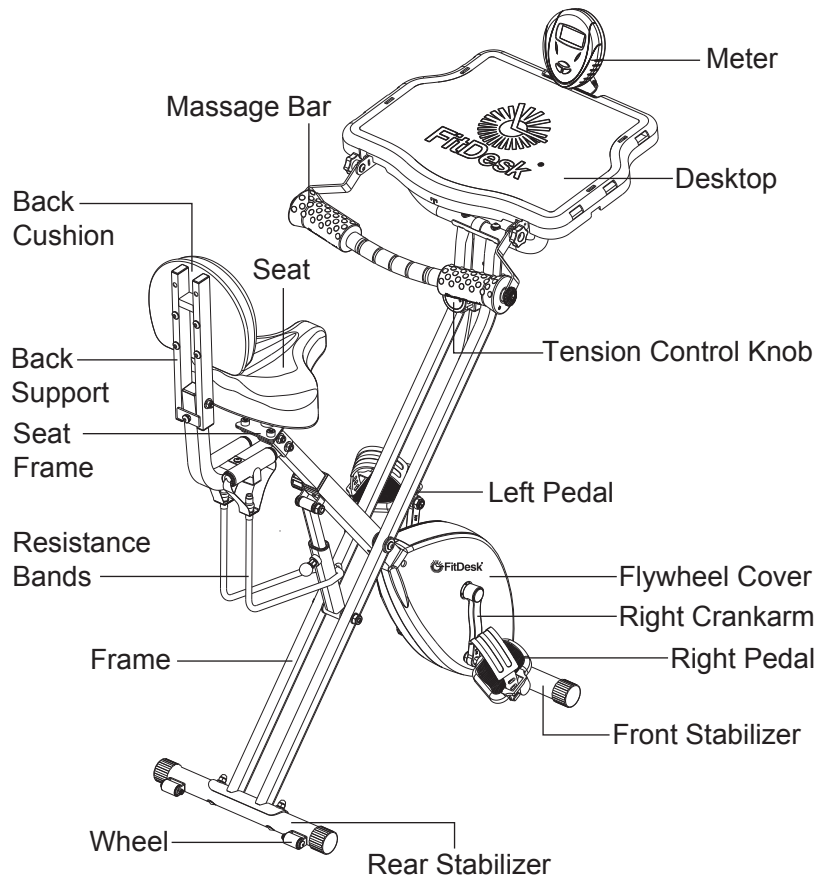



NEED HELP?

CONTACT US FIRST

1-855-713-8887

MONDAY - FRIDAY 9 A.M. - 5 P.M. EST

EASY TO USE CUSTOMER TICKETING

Step 1: www.thefitdesk.com

Step 2: “Support”

Step 3: “Submit A Support Ticket”

customerservice@thefitdesk.com

FOR FASTEST POSSIBLE SERVICE PLEASE HAVE AVAILABLE

Model # (FDX 2.0) - Serial # (located on tubular base safety sticker)

WWW.THEFITDESK.COM

TOOLS

Estimated Assembly Time : 30 minutes

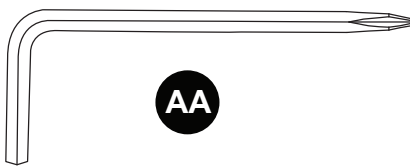

AA. Screwdriver Allen Wrench (Supplied)

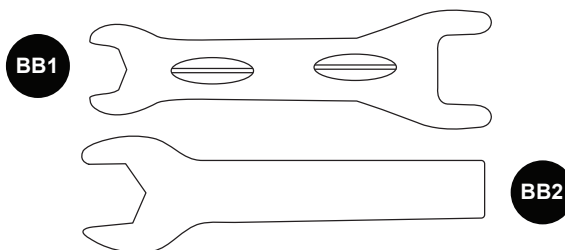

BB1. / BB2. Wrenches (Supplied)

Each **FitDesk®** comes equipped with one Screwdriver Allen Wrench (**AA**) and Wrenches (**BB1**) (**BB2**). It is recommended if you have your own tools, that you use a 1/2" socket with drive and a 15 mm Wrench to tighten the pedals from time to time.

HARDWARE

Note: Hardware and Tools not shown to actual size.

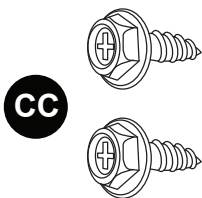

CC. (2) Self-Tapping Screws

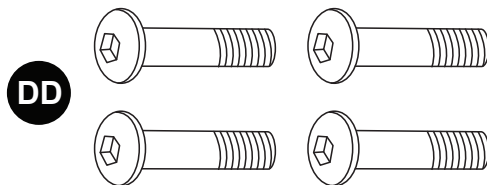

DD. (4) Saddle Back Allen Bolts

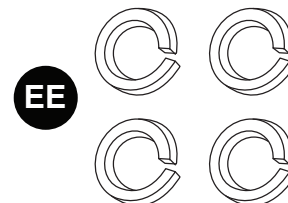

EE. (4) Saddle Back Lock Washers

KNOBS

**NOTE: Do not over tighten.
This could cause the knobs to strip.**

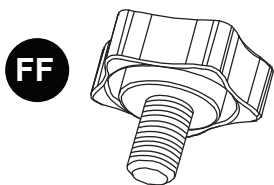

FF. (2) Sliding Adjustment Knobs



GG. (2) Desk Attachment Knobs

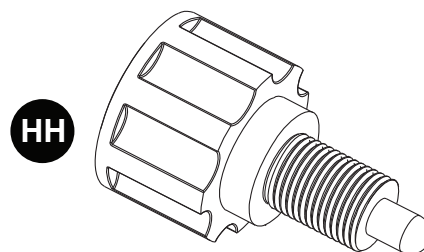

HH. Saddle Height Adjustment Knob
(Pre-Assembled on Frame)

NOTE: If Parts or hardware are missing contact customer service immediately.

Please do not discard your packaging until your entire **FitDesk®** is fully assembled. Some parts are purposely packaged in cardboard or Styrofoam and can mistakenly be thrown away with the packaging.

PARTS

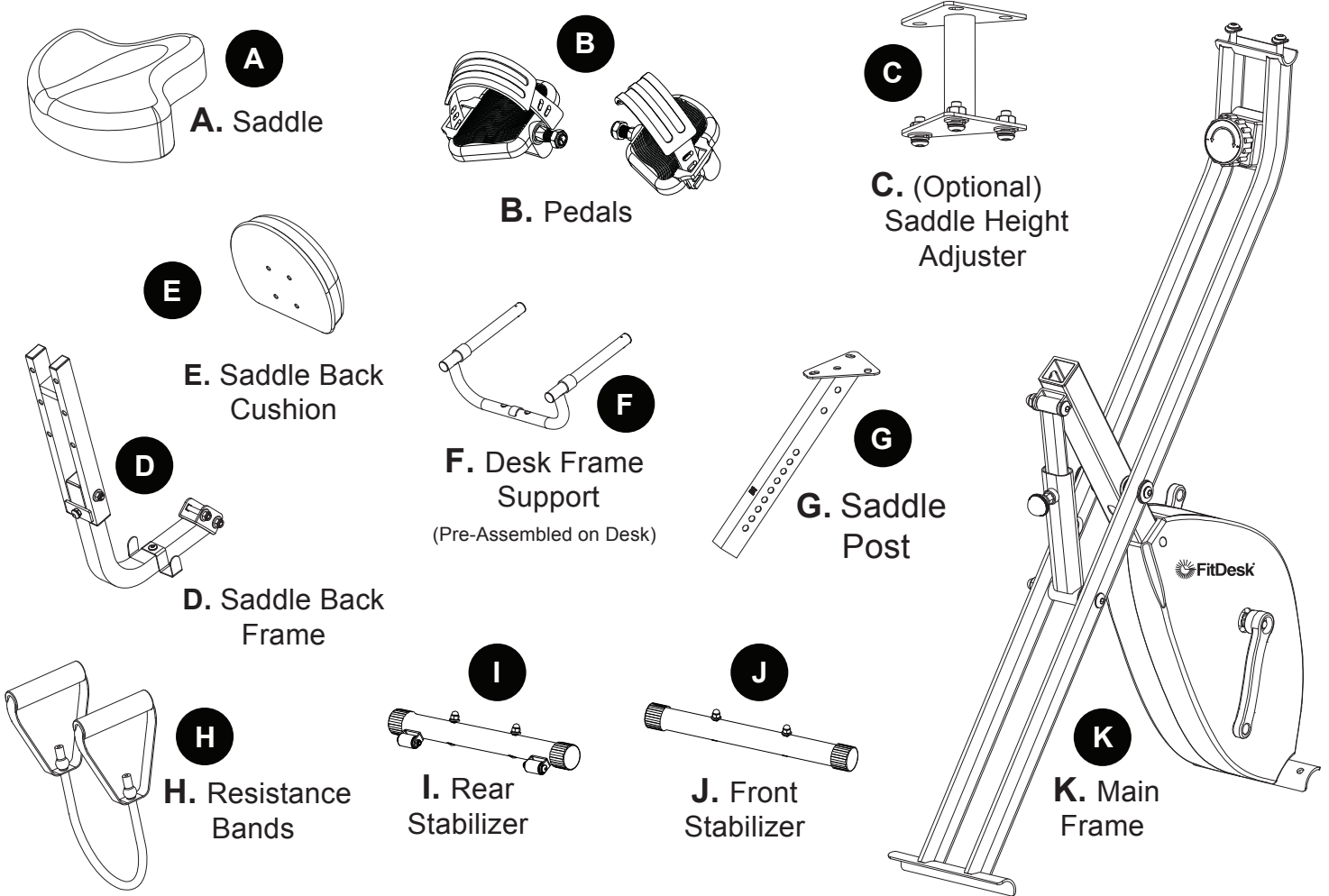

DESK PARTS & COMPONENTS

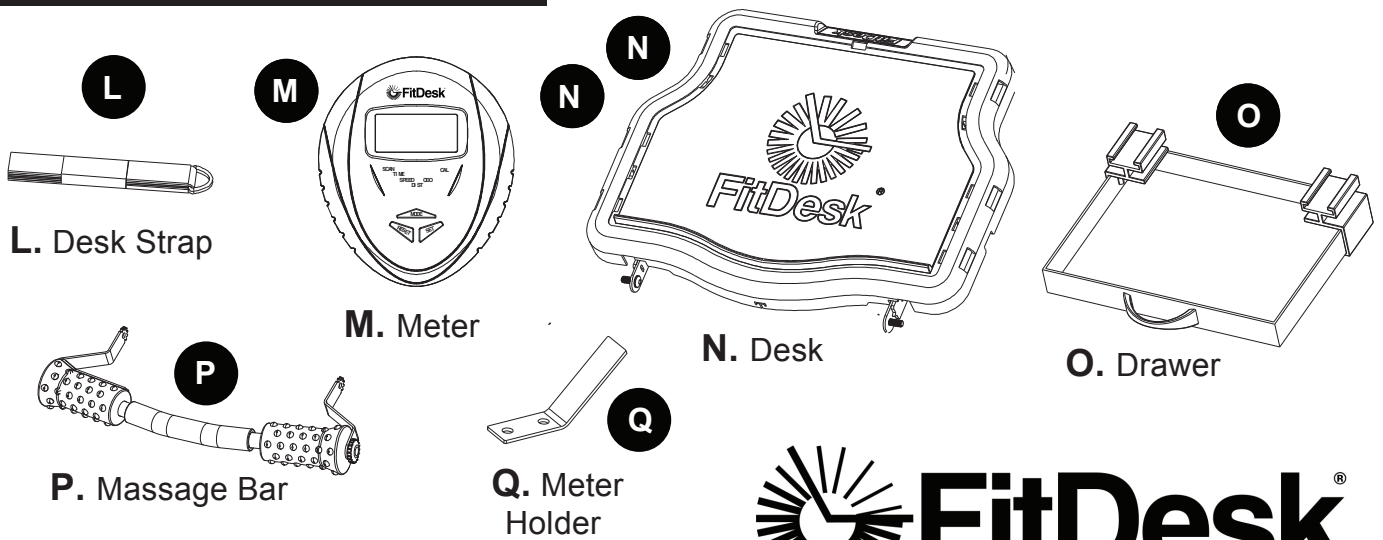

BEFORE YOU BEGIN

Download the FREE BILT™ App

**Search FitDesk® and assemble
this product with easy to understand 3-D instructions**

BILT.™

Set-up Made Easy

BILT™ equips you with 3D, interactive, step-by-step instructions for a quicker assembly, repair, maintenance and warranty experience.



Download on the
App Store



GET IT ON
Google Play

For Android, Apple, Tablets and Phones

ASSEMBLY

NOTE: Before assembly please check all parts carefully.

We take great care to deliver quality products that will last for years. However, even with years of manufacturing experience and high levels of quality control, problems still occur from time to time. If you experience a problem with any part of your new **FitDesk®**, please contact us before returning your product. In most cases, we can quickly solve your issue with technical advice or easily send you a replacement part if needed.

The included Screwdriver Allen Wrench (**AA**) and Wrenches (**BB1**) (**BB2**) are required to complete this assembly. To make the assembly easier, we recommend using a 1/2" inch Socket Wrench, 15mm Wrench, and a number five Allen Wrench.

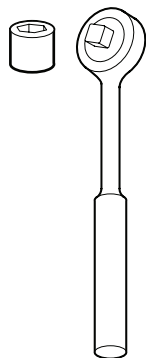

1/2" Socket
Wrench

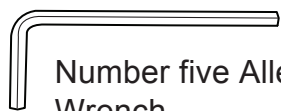

Number five Allen
Wrench

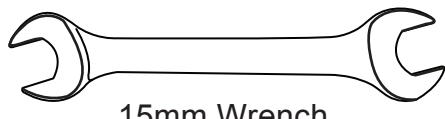

15mm Wrench

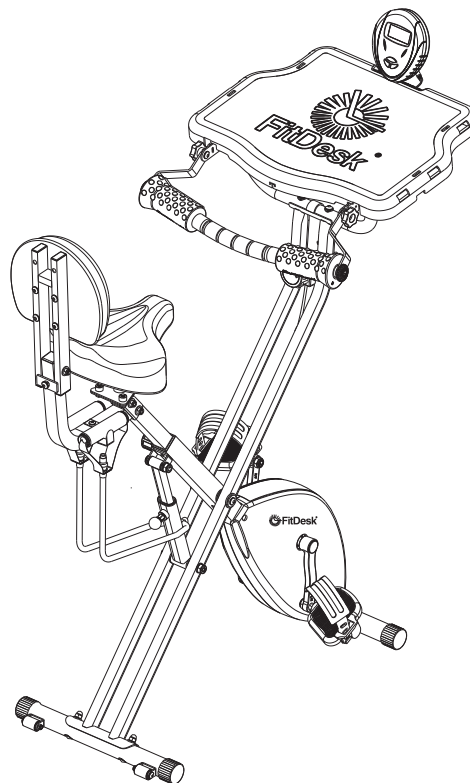

ASSEMBLY

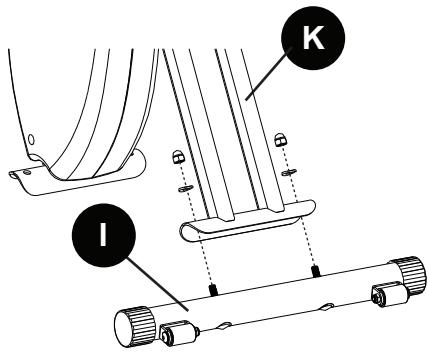

FIGURE 1

Step 1: Install the Rear Stabilizer (I) to the Main Frame (K). Be sure to tighten it securely. **Figure 1**

Note: The Rear Stabilizer (I) has transport wheels.

Note: Most of the mounting hardware is pre-installed for easy matching during assembly.

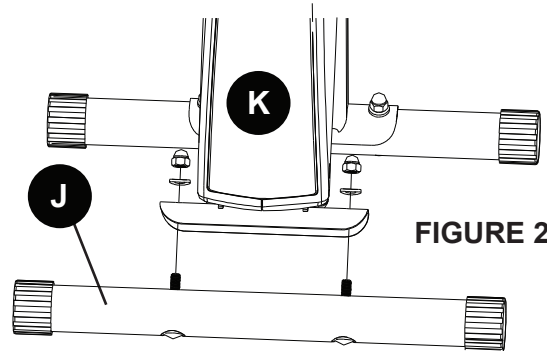

FIGURE 2

Step 2: Install the Front Stabilizer (J) to the Main Frame (K). Be sure to tighten it securely. **Figure 2**

Note: Check Base Stabilizers for tightness periodically.

Step 3: Unlock the Main Frame (K) to the open position by pulling the Frame Lock Pin while pushing lightly with your foot on the stabilizer, then release the Frame Lock Pin.

Figure 3

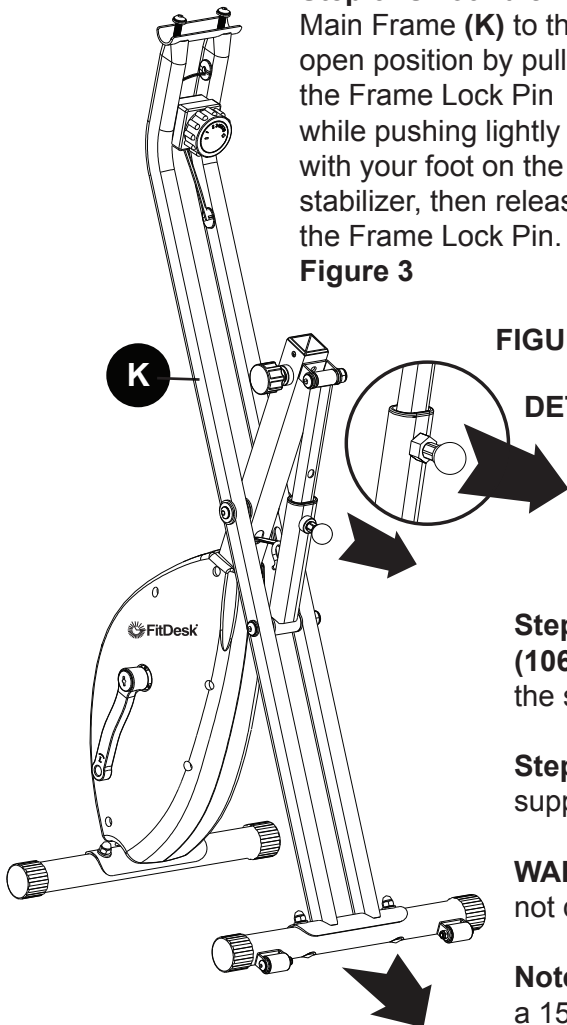

FIGURE 3

DETAIL

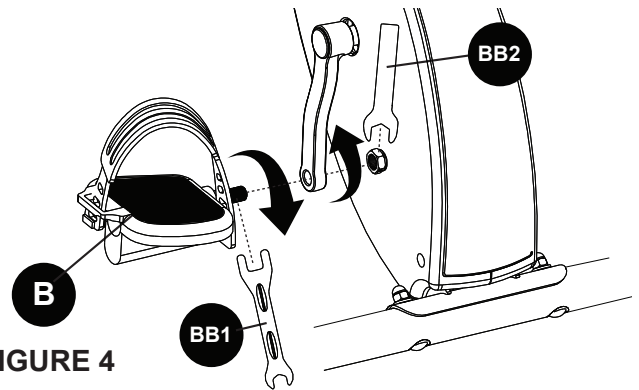

FIGURE 4

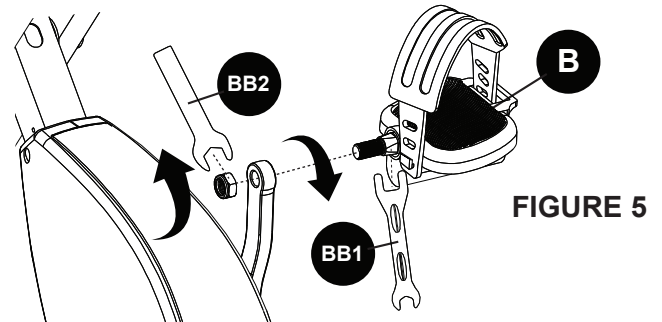

FIGURE 5

Step 4: Using the supplied Wrenches (BB1) (BB2) attach the Left Pedal (B) (106L) to the crank arm by tightening the pedal and holding the back nut at the same time. (Left pedal is reverse thread) **Figure 4**

Step 5: The Right Pedal (B) (106R) is installed the same way using the supplied wrenches. (Right pedal is not reverse thread) (BB1) (BB2). **Figure 5**

WARNING: Make sure the pedals are threaded properly to ensure you do not damage the threads.

Note: The Pedals must be made extra tight. Use the included Wrenches or a 15mm wrench to finish tightening.

ASSEMBLY

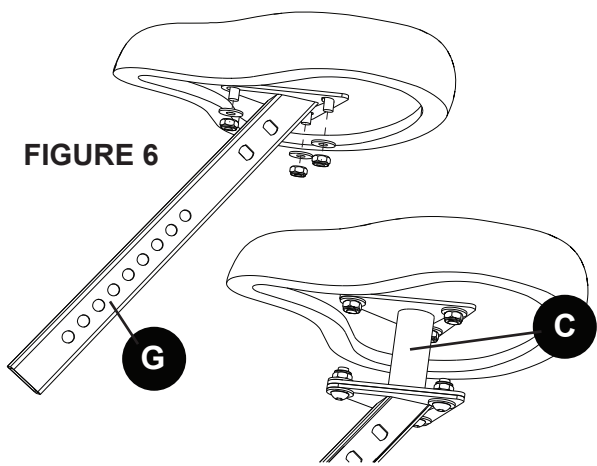

FIGURE 6

Step 6: Assemble the Saddle (A) to the Saddle Tube (G), using attached wrench (BB1) Figure 6

Note: Make sure the lock nuts are extra tight.

Note: The FitDesk® is supplied with an optional Saddle Height Extender (C) for increased leg extension if needed. It is recommended for use if you are taller than 5 feet 9 inches, or 175cm.

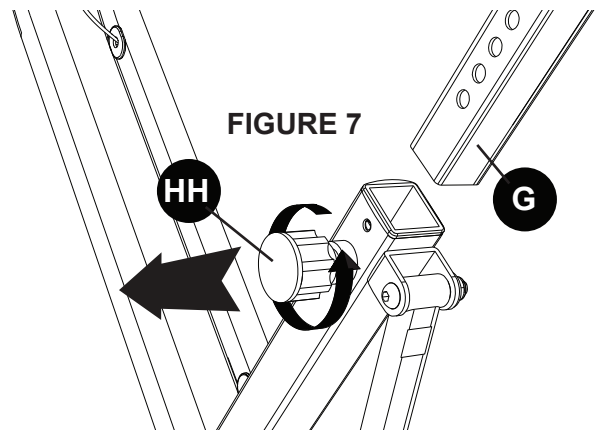
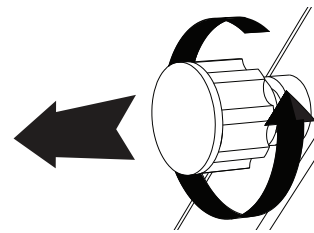

FIGURE 7

Step 7: To attach the Saddle (A) and Saddle Tube, (G) loosen the Saddle Tube Adjuster Knob (HH). Figure 7



Note: You do not have to remove the knob to adjust the height. Loosen the knob and pull, then retighten when the desired height is reached.

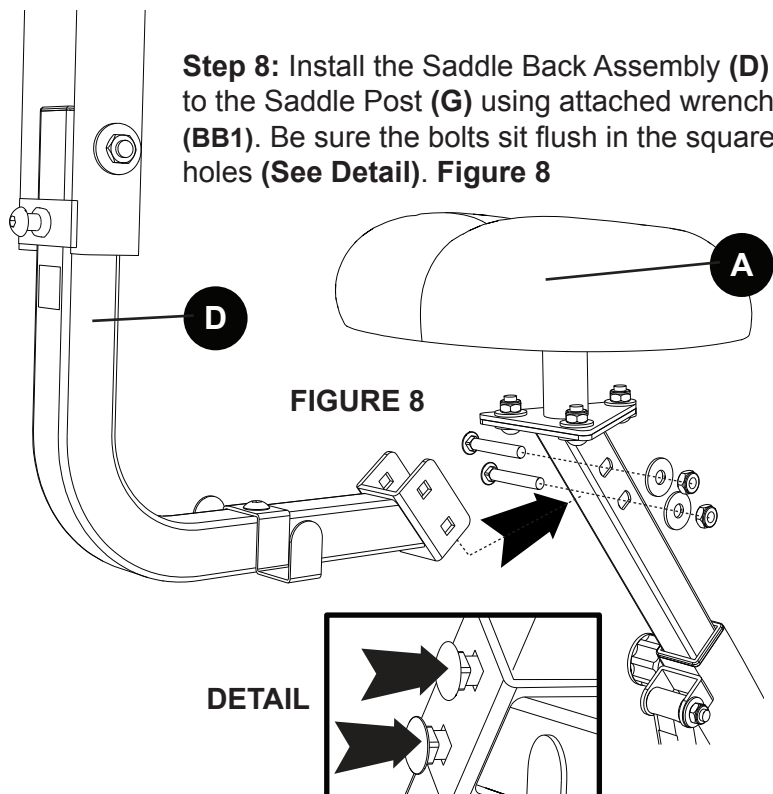

FIGURE 8

Step 8: Install the Saddle Back Assembly (D) to the Saddle Post (G) using attached wrench (BB1). Be sure the bolts sit flush in the square holes (See Detail). Figure 8

DETAIL

Step 9: Install the Saddle Back Cushion (E) to the Saddle Post (D) using attached Allen Wrench (AA). Be sure the Allen Bolts (DD) and Lock Washers (EE) sit flush in the holes. Figure 9

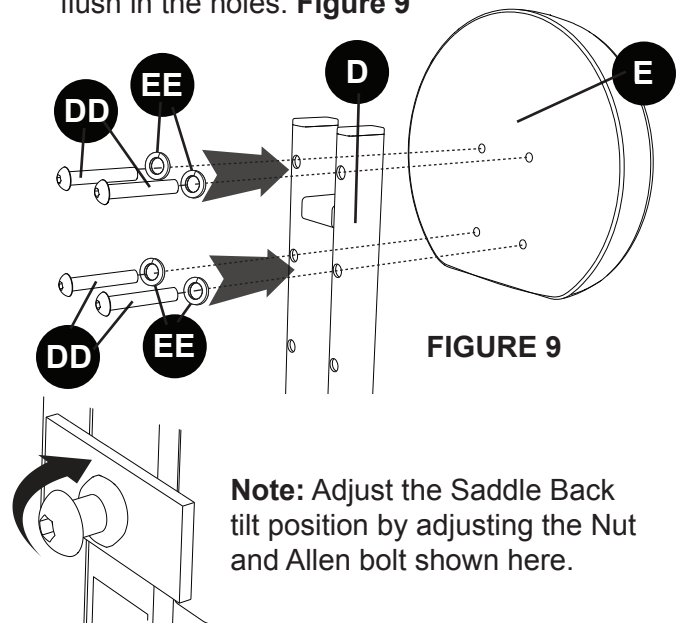
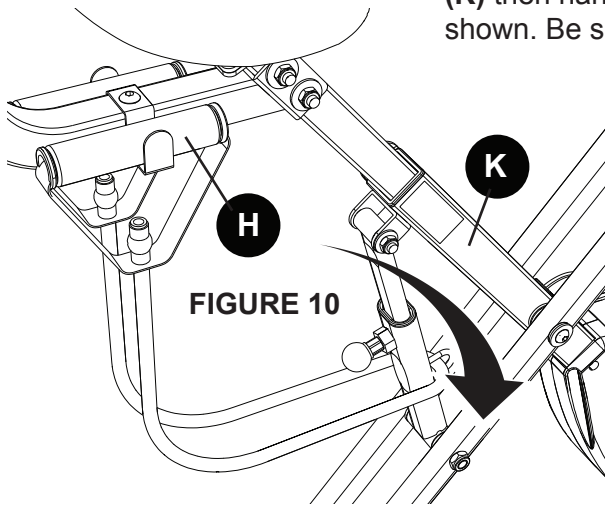

FIGURE 9

Note: Adjust the Saddle Back tilt position by adjusting the Nut and Allen bolt shown here.

ASSEMBLY

Step 10: Place one Resistance Band Handle through the opening in the frame, (K) then hang the handles (H) on the Resistance Band Hooks (3242) like shown. Be sure to place the Tube into the metal loop. **Figure 10**



WARNING: The Resistance Bands are for light use only. Do not overstretch the Resistance Bands.

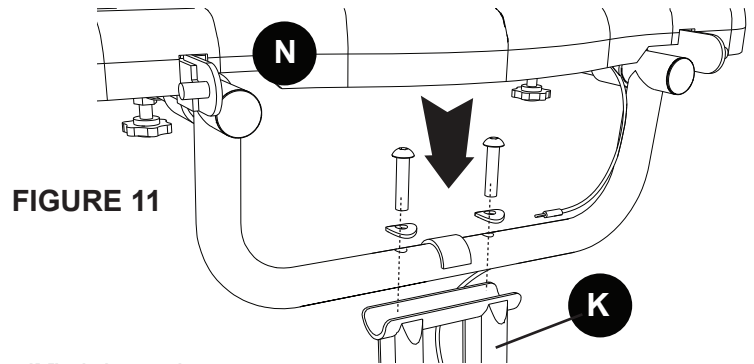

Step 11: Place the Desk (N) over the bikes Main Frame (K) tighten the two Allen Bolts and Washers using attached Allen Wrench (AA). **Figure 11**
Note: Do not over tighten.

Step 12: Slide in the Drawer (O) at the back of the desktop. (N) **Figure 12**

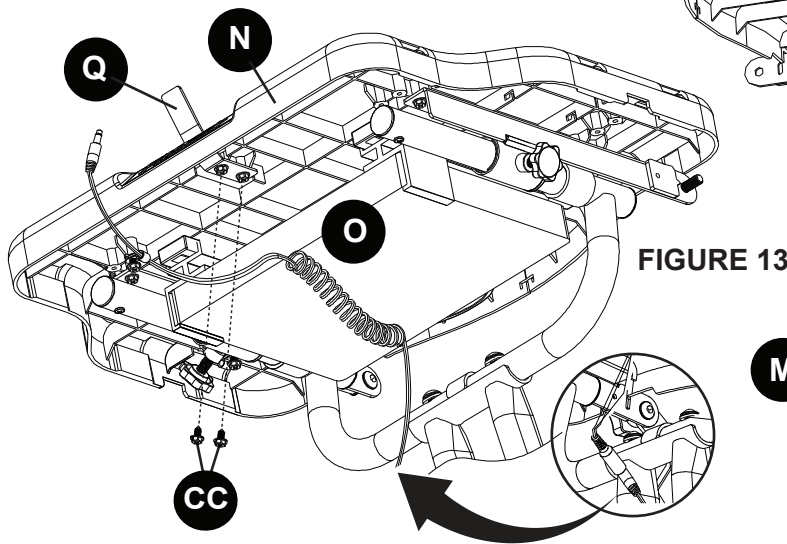
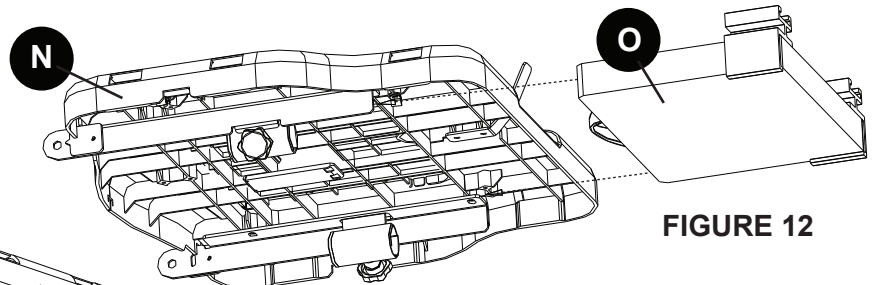

Step 13: Once Desk (N) and Drawer (O) is installed, connect the Meter Wire to the wire on the frame. Slide the Meter Holder (Q) and Meter Wire (9108) through the opening in the top center of the Desk (N), then install and tighten the two screws (CC) through the Meter Holder (Q). **Figure 13**

Step 15: Slide the Meter (M) onto the Meter Holder (Q) and then plug the Meter Wire (9108) into the back of the Meter (M). **Figure 15**

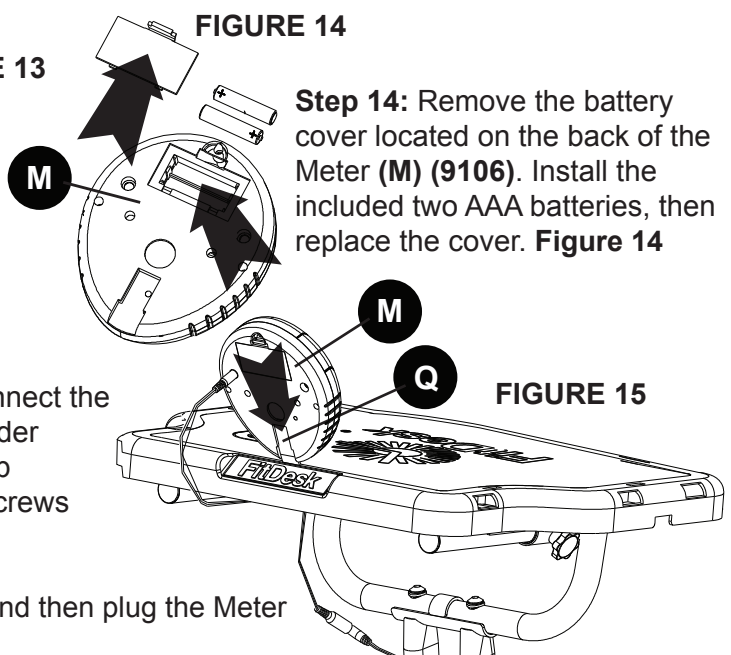

Step 14: Remove the battery cover located on the back of the Meter (M) (9106). Install the included two AAA batteries, then replace the cover. **Figure 14**

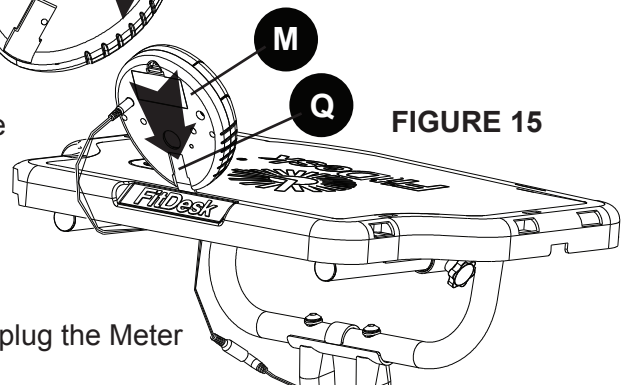

ASSEMBLY

Step 15: Attach the Massage Bar (O) to the Desk using the Desk Knobs (GG). The Massage Bar (O) can be set in three different positions above horizontal. Choose a desired height, but be sure to align each Support Arm in the same position on each side. Tighten the Desk Knobs (GG) securely. **Figure 15**

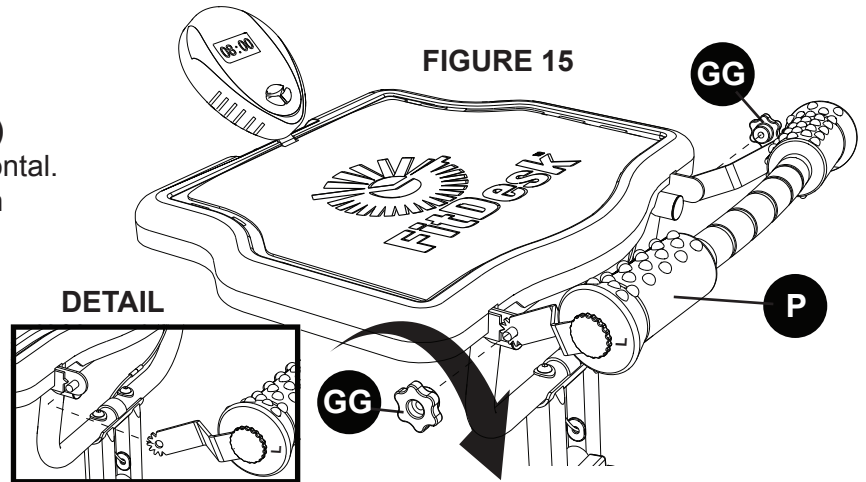

WARNINGS AND LABELS

NOTE: Read all warning stickers before operating this product.

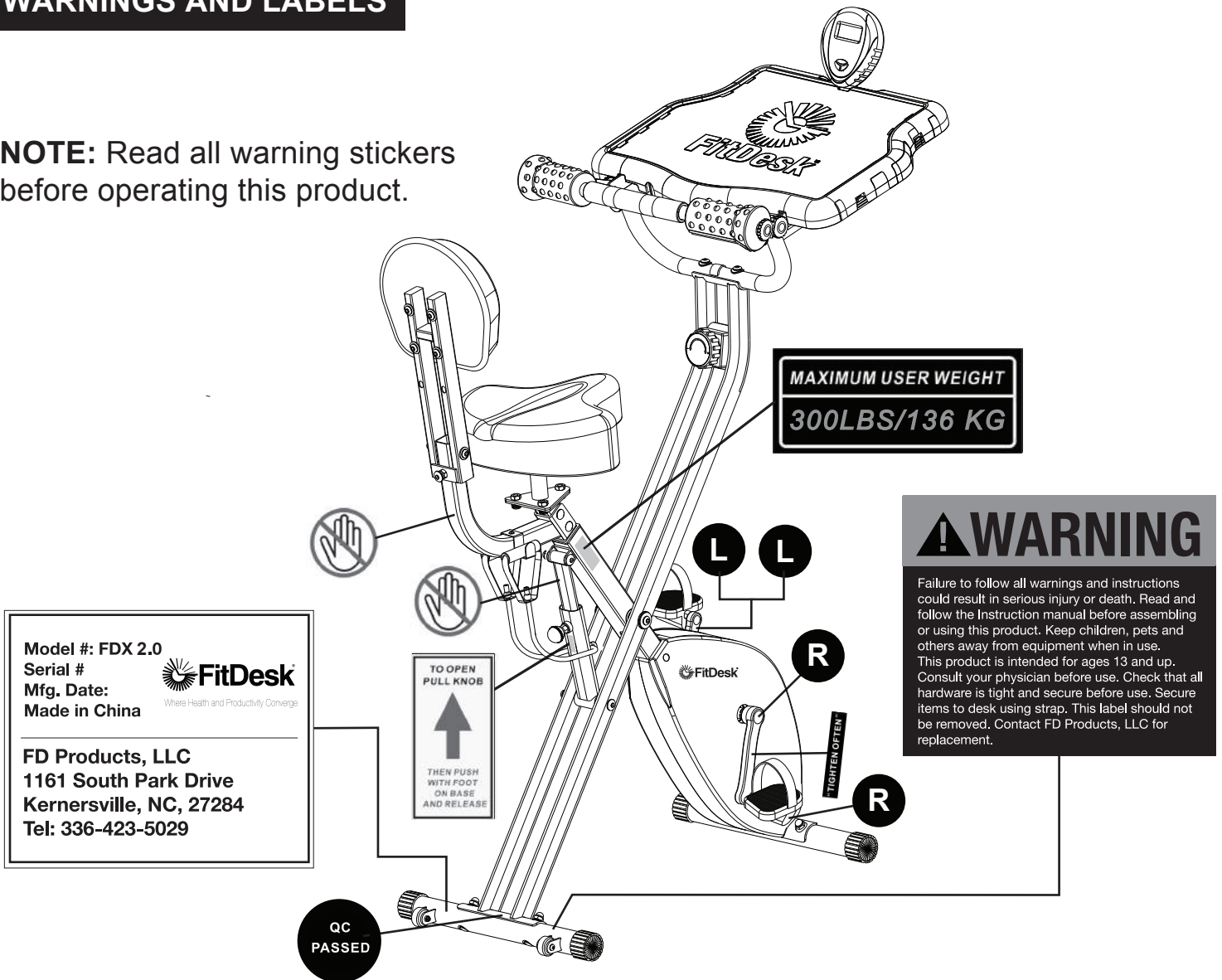

Model #: FDX 2.0
 Serial #
 Mfg. Date: 
 Made in China Where Health and Productivity Converge

FD Products, LLC
 1161 South Park Drive
 Kernersville, NC, 27284
 Tel: 336-423-5029

! WARNING

Failure to follow all warnings and instructions could result in serious injury or death. Read and follow the Instruction manual before assembling or using this product. Keep children, pets and others away from equipment when in use. This product is intended for ages 13 and up. Consult your physician before use. Check that all hardware is tight and secure before use. Secure items to desk using strap. This label should not be removed. Contact FD Products, LLC for replacement.

WARMING UP

WARNING: Always check with your physician before starting any type of exercise program.

Before you use the **FitDesk®**, it is advisable to warm up and stretch your muscles. Simple warm up exercises and stretches can help you be more efficient and safer during your time on the **FitDesk®**.

STRETCHING

Hold each stretch 10 to 30 seconds. If you feel you need more, stretch the other side and return for another set of stretching.

- The stretch should be strong, but not painful.
- Do not bounce.
- Breathe while you're stretching. Exhale as you stretch, inhale while holding the stretch.

SUGGESTED BASIC STRETCHING EXERCISES



SEATED HAMSTRING STRETCH

Sit on the floor, a step or on a chair with one leg stretched out in front of you, the other bent. Sit up tall and then lean forward as far as you comfortably can, stretching the back of the leg. You can grab onto the thigh, calf, ankle or foot to pull you further into the stretch. Hold for 15-30 seconds and switch sides.



HIP FLEXOR LUNGE STRETCH

Get into a lunge position on the floor, right foot forward and left knee back, both knees at about 90 degrees. Keeping the torso straight and abs engaged, lunge forward, gently pressing until you feel a stretch in the front of the hip. You can also squeeze the glutes for a deeper stretch. Hold for 15-30 seconds and switch sides.



SEATED STRETCH

Sit with both legs straight. Bend your left knee and cross it over your right leg so that your left ankle ends up by your right knee. Now twist your torso so that your right elbow ends up docking on your left knee. You can put some pressure from your elbow on your knee to push it in towards the midline of your body to increase the intensity of the stretch. Hold for 15-30 seconds and switch sides.

COOL DOWN

It is good to also stretch after using the **FitDesk®** when you're cooling down because your limbs, muscles and joints are still warm. Stretching can help reduce the buildup of lactic acid, which can lead to muscles cramping and stiffness.

OPERATIONAL INSTRUCTIONS

NOTE: Before operating please read carefully

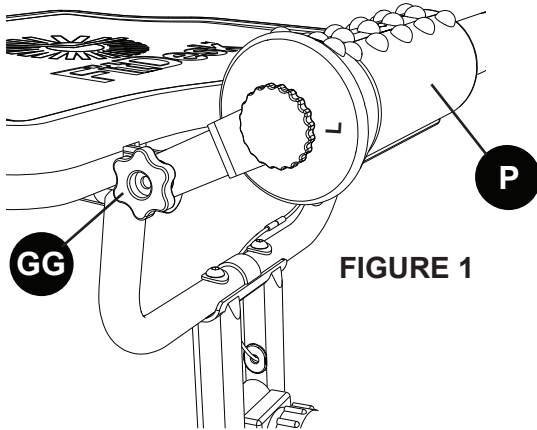

FIGURE 1

MASSAGE BAR

To adjust the Massage Bar, (**P**) loosen the left and right knobs, (**GG**) then lift or lower to the best position. Tighten the knobs (**GG**) when done. **Figure 1**

RIDE POSITION AND ADJUSTMENTS

The Desk (**N**) and ride position can be adjusted by loosening the knobs (**FF**) located on the underside of the Desk Slide. Slide the Desk (**N**) forward or back to a comfortable position, then tighten the knobs (**FF**). **Figure 2**

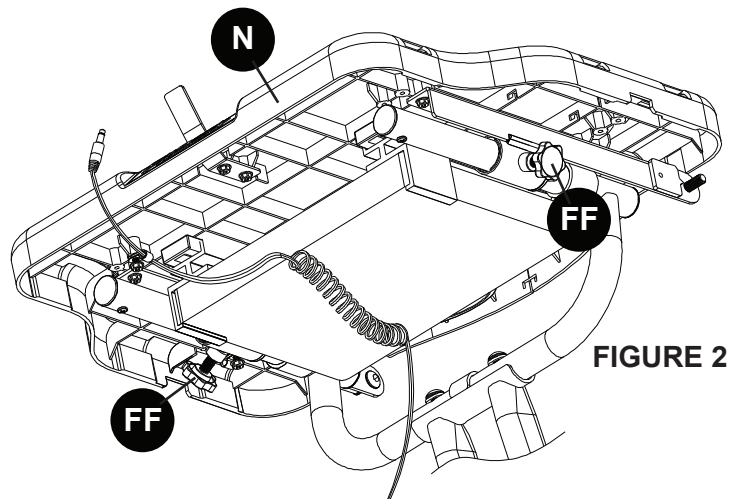

FIGURE 2

DESK STRAP

The **FitDesk**® also comes with a Desk Strap (**L**) (3240). Thread the strap through the openings in the Desk (**N**) and around your laptop or device. **Figure 3**

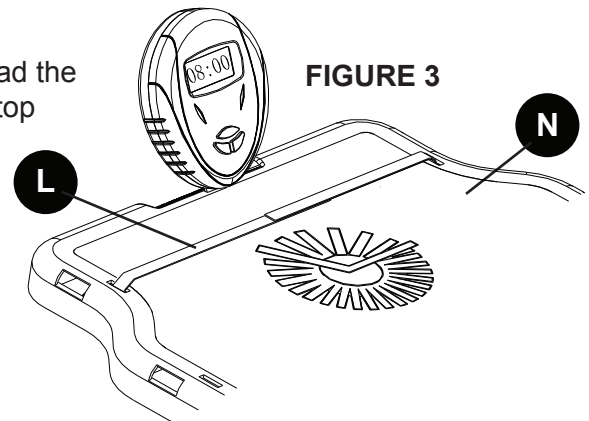

FIGURE 3

Note: Always secure laptop or devices when using the bike.

OPERATIONAL INSTRUCTIONS

NOTE: Before operating please read carefully

RESISTANCE KNOB

Turn Dial from 1-8 to change resistance. To increase the load, turn the knob located on the main frame clockwise. To decrease the load turn the tension knob counter clockwise.

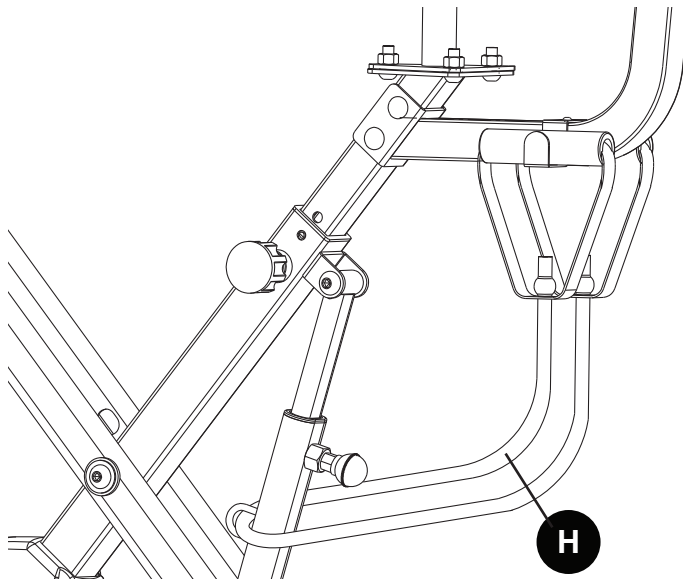
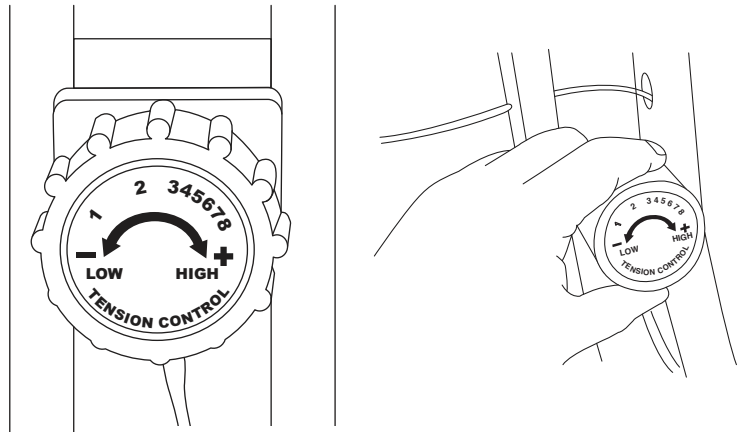

RESISTANCE BANDS

Your **FitDesk®** is supplied with a Premium Latex Resistance Band (**H**). Having this proven fitness staple near you throughout the day is a great option for more exercise. Here we want you to take a look at ways you can use your **FitDesk®** Resistance Bands and also show you how to maintain them for maximum safety.

How to use the **FitDesk®** Resistance Bands:

- Stop pedaling
- Reach under saddle and grab both handles.
- Raise one arm at a time, to a comfortable position.
- Repeat the motion.



WARNING: BANDS ARE FOR LIGHT USE ONLY. DO NOT OVER STRETCH THE RESISTANCE BANDS.

METER / OPERATION

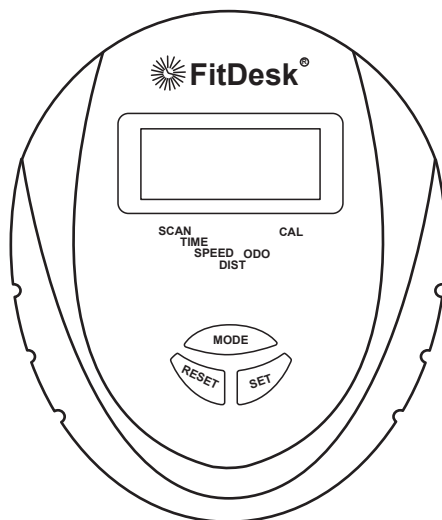
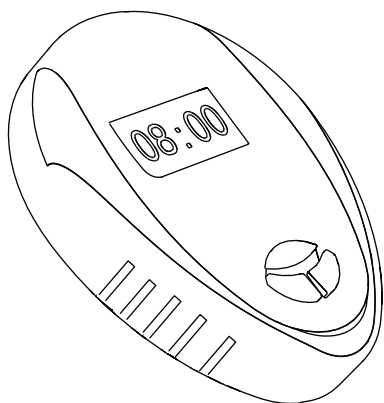

INSTRUCTIONS:

1. Mode button advances the Meter.
 - a. Time in use
 - b. Speed - MPH
 - c. Distance - Miles or KM
 - d. Calories burned
 - e. Total distance on **FitDesk**[®] - ODO in Miles or KM.
2. Reset button allows for Meter to be reset for time. Distance and Calories Mode.
 - a. Stop pedaling then push reset to reset each Mode.
3. Scan will automatically start at each Mode.
 - a. To Stop Scan press mode button again.
 - b. Scan indicator is on screen when in Scan Mode.
4. Set button to count down feature. Hit the Mode button to stay on "Time" make sure you are not in Scan Mode. Hit "Set" until the desired count down time is displayed.

TROUBLESHOOTING:

1. Meter will turn on as soon as you start pedaling.
2. If Meter does NOT show zero even if you push the Mode Button.
 - a. Check to see that batteries are fresh and properly installed.
3. If zeros display when you press the Mode Button, But not when pedaling.
 - a. Check connection to Meter and connection from frame to Meter.

BATTERY INSTRUCTIONS

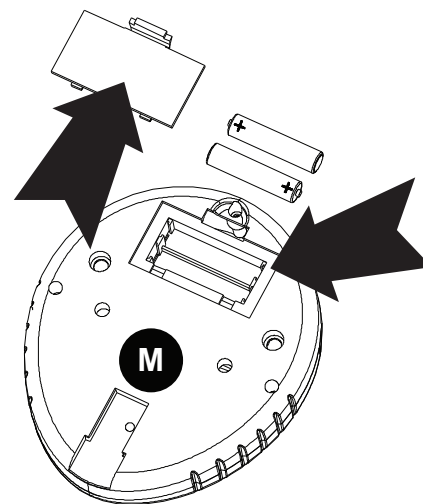

INSTALLING AND REPLACING FitDesk[®] METER BATTERIES:

The Meter (**M**) operates using two AAA batteries.

Batteries are included

Refer to the illustration to install or replace the batteries.

For Questions Contact:
1-855-713-8887

MONDAY - FRIDAY 9 A.M. - 5 P.M. EST



SET UP / STORAGE

This model **FitDesk®** uses a quick release frame unlock design.

As a safety precaution please use the technique shown here when opening and closing frame.

Figure 1. TO OPEN: Pull pin on frame support while placing foot on base. Open frame then release pin, then pull desk toward you.

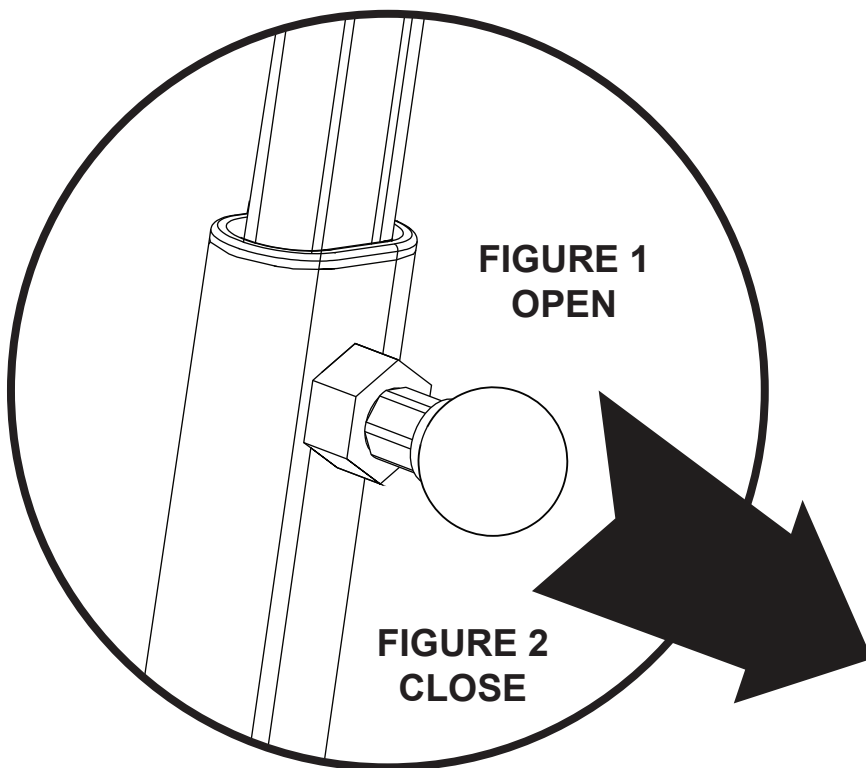
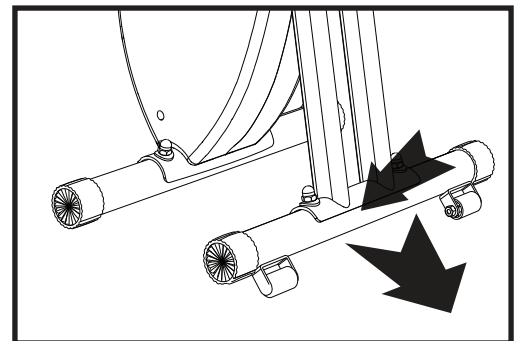

FIGURE 1 OPEN



Place Feet As Marked

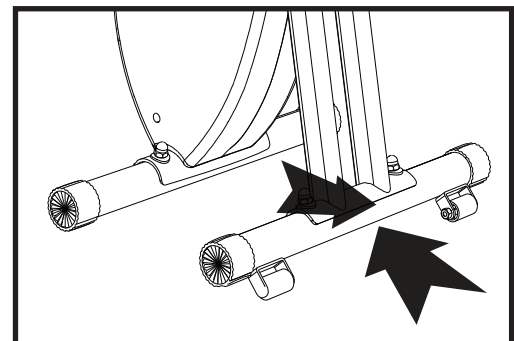

FIGURE 2 CLOSE

Figure 2. TO CLOSE:

1. Remove any items on desk.
2. Put foot on base, pull pin and close frame folding desk in.

NOTE: Frame is locked when **PULL PIN** clicks into place.

Before transporting. Fold frame in closed position with support pin engaged to prevent opening. Tighten desk knobs. Use transport wheels when possible. The frame must be in the closed and locked position prior to transport.

MAINTENANCE AND TROUBLESHOOTING

The integrity of the **FitDesk®** bike can only be maintained when it is regularly maintained for damage and wear. Special attention should be given to the following.

HARDWARE

Verify that all bolts are present and properly tightened.

TIP: Inspect nuts, screws and knobs on a weekly basis.

FRAME, SEAT, SEAT MOUNT

Properly adjust seat back angles for multiple position use.

NOTE: Check frame, seat, seat mount, desk mounting areas for wear.

WARNING: Do not use if any sign of frame cracking. Worn or damaged parts and components must be replaced immediately.

PEDALS

Check pedal (**B**) tightness with 15mm wrench **WHEN NEW - THEN AFTER** 30 miles.

NOTE: Make Pedals **EXTRA** Tight during Assembly.

BASE STABILIZERS

Check Base Stabilizers bolts for tightness periodically.

METER

Refer to page 14 in this manual for operation instructions.

If the meter is not resetting or turning on first check the battery. Replace with a new battery.

Check the battery springs to make sure proper contact is being made.

TIP: Check meter wires for any damage.

WARRANTY

This limited warranty is applicable to each original end-customer (hereinafter “Customer”) purchasing the **FitDesk®** Model: FDX 2.0 consisting of the structural metal frame (hereinafter the “Structural Frame”) and various other non-frame components (hereinafter the “Non-Frame Parts”) sold by FD Products, LLC (hereinafter “Company”) for Customer’s own use and not for resale. The Structural Frame and Non-Frame Parts are collectively referred to herein as the “Products”.

1. LIMITED WARRANTY; EXCLUSIVE REMEDIES:

1.1. **LIMITED WARRANTY ON PRODUCTS:** Company warrants solely to the original Customer that (a) the Structural Frame will be free from defects in materials and workmanship under normal use for a period of ONE (1) YEAR from the date of original retail purchase, and (b) the Non-Frame Parts, will be free from defects in materials and workmanship under normal use for a period of NINETY (90) DAYS from the date of original retail purchase. Notwithstanding the foregoing, the colors and finishes of the Products may vary within a reasonable scope due to unavoidable color variations in different production batches, and such variations shall not constitute a material defect. This limited warranty is limited solely to the original Customer with proof of purchase and is not transferable.

1.2. **THE WARRANTY:** During a covered Product’s limited warranty period, Company will, at Company’s sole option and discretion, (1) repair the defective component or product without charge or (2) replace the defective component or product without charge.

1.3. The foregoing limited warranty is subject to the Customer’s proper storage, transportation, handling and use of the Products as the same are defined within Company’s then-current published guides and instructions for use and care. The limited warranty does not include defects due to normal wear and tear, abuse or misuse, mishandling, neglect, accident, fire, lightning, sunlight or other natural hazard, delivery or transportation damage, failure to follow applicable directions or instructions, or improper or inadequate cleaning, maintenance, care, repairs, modifications, or use beyond a Product’s intended use.

1.4. **LIMITED WARRANTY CLAIMS PROCEDURE:** To obtain performance under this limited warranty, Customer shall notify Company in writing (to FD Products, LLC, 1161 South Park Drive, Kernersville, NC 27284, Attn: Customer Service / Warranty Department), by email (to customerservice@thefitdesk.com), or by telephone (to (336) 423-5029) with a full description of the defect that is covered by warranty and a copy of the dated proof of purchase of the applicable product.

- Company shall review each such claim and issue Customer a return merchandise authorization (“RMA”) in the event that the described defect or condition merits warranty review as determined by Company. Customers who have been issued a RMA shall, at Company’s election, return the covered item to the same physical address listed above for reporting initial claims. Company shall not accept any returned product without a RMA.

- Upon receipt, Company will evaluate the returned product(s) to determine if there is a warranty claim and, if so, how Company wishes to remedy the same. During a covered product’s respective limited warranty period, Company will, at Company’s sole and absolute option and discretion, (1) repair the defective component or product without charge or (2) replace the defective component or product without charge. Refunds are not available pursuant to this limited warranty.

- Customer is solely responsible for transportation of the covered product(s) to the Company for evaluation (if applicable and requested by Company). In the event that Company determines that a claim under this limited warranty is justified, Company shall be responsible for transportation of the repaired, corrected, replaced or exchanged product back to Customer. Customer shall be solely responsible for the transportation of any product back to Customer if Company determines that a claim under this warranty is not justified.

- Any repaired, corrected, replaced or exchanged Products shall be subject to the Limited Warranty set forth to the duration of the original limited warranty period as set forth in Section 1.1. and not for any extended duration, following their repair, correction, replacement or exchange.

WARRANTY

1.1. IF A COMPANY PRODUCT DOES NOT CONFORM TO THESE LIMITED WARRANTIES, THE PURCHASER'S SOLE AND EXCLUSIVE REMEDY IS, AT COMPANY'S SOLE AND EXCLUSIVE OPTION, THE (1) REPAIR OF ANY DEFECTIVE PRODUCT OR COMPONENT PART OR (2) REPLACEMENT OF ANY DEFECTIVE PRODUCT OR COMPONENT PART. THE LIMITED WARRANTY AND REMEDIES SET FORTH ABOVE ARE EXCLUSIVE AND MADE IN LIEU OF ALL OTHER WARRANTIES, REMEDIES, RIGHTS OR CONDITIONS, WHETHER ORAL OR WRITTEN, EXPRESS OR IMPLIED, EITHER IN FACT OR BY OPERATION OF LAW, STATUTORY OR OTHERWISE, INCLUDING THE IMPLIED WARRANTIES OF MERCHANTABILITY AND FITNESS FOR A PARTICULAR PURPOSE. COMPANY SPECIFICALLY DISCLAIMS, WITHOUT LIMITATION, ANY AND ALL OTHER WARRANTIES, EXPRESS OR IMPLIED, OF ANY KIND. IF COMPANY CANNOT LAWFULLY DISCLAIM IMPLIED WARRANTIES UNDER THIS LIMITED WARRANTY, ALL SUCH WARRANTIES, INCLUDING THE IMPLIED WARRANTIES OF MERCHANTABILITY AND FITNESS FOR A PARTICULAR PURPOSE, ARE LIMITED IN DURATION TO THE DURATION OF THIS LIMITED WARRANTY. The Company does not assume or authorize any person to assume for them any other liability in connection with the Products.

2. EXCLUSION AND LIMITATION OF LIABILITY:

IN NO EVENT, WHETHER BASED ON CONTRACT OR TORT OR OTHER LEGAL THEORY, SHALL COMPANY BE LIABLE FOR ANY INDIRECT, INCIDENTAL, PUNITIVE, SPECIAL OR CONSEQUENTIAL DAMAGES, INCLUDING BUT NOT LIMITED TO, DAMAGES TO OTHER PROPERTY, INCONVENIENCE, DAMAGES FOR LOSS OF PROFITS, REVENUE, GOODWILL OR USE, INCURRED BY CUSTOMER OR ANY THIRD PARTY, WHETHER IN AN ACTION IN CONTRACT, TORT, STRICT LIABILITY, OR IMPOSED BY STATUTE, OR OTHERWISE, EVEN IF ADVISED OF THE POSSIBILITY OF SUCH DAMAGES. Some states do not allow the exclusion or limitation of incidental or consequential damages or exclusions or limitations on the duration of implied warranties or conditions, so the above limitations or exclusions may not apply to Customer. In jurisdictions that limit the scope of or preclude limitations or exclusion of remedies or damages, or of liability, such as liability for gross negligence or willful misconduct or do not allow implied warranties to be excluded, the limitation or exclusion of warranties, remedies, damages or liability set forth above are intended to apply to the maximum extent permitted by applicable law. This limited warranty gives the Customer specific legal rights, and the Customer may also have other rights that vary by state, country or other jurisdiction.

3. SEVERABILITY:

If any provision of this limited warranty is held to be illegal, invalid or otherwise unenforceable, such provision will be enforced to the extent possible consistent with its stated intention, or, if incapable of such enforcement, will be deemed to be severed and deleted from this limited warranty, while the remainder of the terms of this limited warranty will continue in full force and effect.

4. DISPUTE RESOLUTION:

This FitDesk Limited Warranty shall be governed by and construed in accordance with the laws of the State of North Carolina, without regard to its principles of conflicts of law. The parties acknowledge the exclusive jurisdiction of the federal and state courts of the State of North Carolina. Any claims or disputes under this FitDesk Limited Warranty shall be heard exclusively in any state or federal courts sitting in Guilford County, North Carolina, and both parties expressly consent to the personal jurisdiction and venue of the North Carolina state and federal courts for such actions.



COMPLETE PARTS LIST

DESCRIPTION:	QTY:	DESCRIPTION:	QTY:
1. Resistance Adjuster	1	54. Nylon Lock Nut	1
2. Oval Head Cross Screws MS-20L	1	55. Stabilizer Cap	4
3. Meter Wire	1	56. Front and Back Stabilizer	2
4. Oval Head	6	57. Hooded Nut	4
5. Curved Washer	6	58. Oval Head Cross Screw M6x45L	2
6. Spring Washer for M8	9	59. Nylon Nut M6	2
7. Gearbox Plate	1	60. Universal Moving Wheel	2
8. Inner Tube Gum Cover	1	61. Saddle Tube	1
9. Zinc Alloy Bearing Bracket	2	62. Seat Back Bent Pipe	1
10. Bearing	4	63. Carriage Bolt	2
11. Phillip Head M6-10-15L and M6 Locking Washer	6/6	64. Flat Washer	2
12. Flywheel	1	65. Nylon Nut M8x1.25	2
13. Main Belt Wheel	1	66. Universal Saddle Extender	1
14. Axial Spring Ring	7	67. Saddle Back Tube	1
15. Curve Washer	2	68. Hex Nut M8x1.25	1
16. Idle Wheel	1	69. Oval Head Socket Head Screw M8x15L	1
17. Drive Shaft	1	70. Eva Foam Rubber Cushion	1
18. Bearing	2	71. Spacer	2
19. Spacer	1	72. Tube Plug	4
20. Hex Nut M10-1.25	2	73. Flat Head Socket Head Screw	1
21. Idle Wheel Adjuster	2	74. Flat Washer	5
22. Idler Axle	2	75. Armrest Arm	1
23. Bearing	2	76. Foam Cover for Armrest Arm	1
24. Circlip	2	77. Left PU Roller	2
25. Flat Washer	3	78. Right PU Roller	3
26. Nylon Nut M10-1.25	1	79. Armrest Adjustment Plate	2
27. Magnet Plate	1	80. Armrest Adjustment Knob M8	2/2
28. Spring	1	81. Desk	1
29. Hex Screw M6-15	1	82. Left Desk Slider	1
30. Belt 240J	1	83. Cover for Slider	2
31. Belt 230J	1	84. Adjustment Knob	4
32. Meter Wire Bottom Part	1	85. Right Desk Slider	1
33. Oval Head Cross Screw M1-10	1	86. Self-Tapping Screw	6
34. Left Chain Cover	1	87. U Shaped Handlebar	1
35. Right Chain Cover	1	88. Round Tube Plug / Foam Ring	4/2
36. Front Cover	1	89. Left Pedal Nut	1
37. Oval Head Tapping Screw	4	90. Right Pedal Nut	1
38. Oval Head Tapping Screw	4	91. Saddle	1
39. Crank Arm Bolt M10-1.25	1	92. Flat Washer	3
40. Crank End Plug M20	2	93. Nylon Nut M8x1.25	3
41. Support Axis Pin	1	94. Seat Back	1
42. Metal Collar	4	95. Resistance Bands	1
43. Plastic Collar	2	96. Spring Loaded Saddle Height Adjuster	1
44. M8 Special Washer	2	97. Meter Holder	1
45. Flat Head Socket Head Screw M8-15L	2	98. Square Tube Plug	2
46. Rubber Meter Wire Plug	3		
47. Upper Support Bar	1		
48. Adjusting Support Bar	1		
49. Shaft Sleeve	2		
50. Cover for Support Bar	1		
51. Frame Lock Pin	1		
52. Socket Head Screw M10x50L	1		
53. Socket Head Screw M10x100L	1		

REPLACEMENT PARTS

9018 Main Frame	1	106L Petal Left 9/16"	1
9100 Right Crank 9/16"	1	106R Petal Right 9/16"	1
9102 Left Crank 9/16"	1	107 Drawer	1
9106 Meter	1	108 Slide Rail	2
9108 Meter Wire	1	109 Screws	4
103A Allen Wrench w Phillips Head	1	3240 Desk Strap	1
103B Wrenches	2	3242 Resistant Band Hooks	1
		3243 Resistant Band Hook Screw	1

COMPLETE PARTS LIST

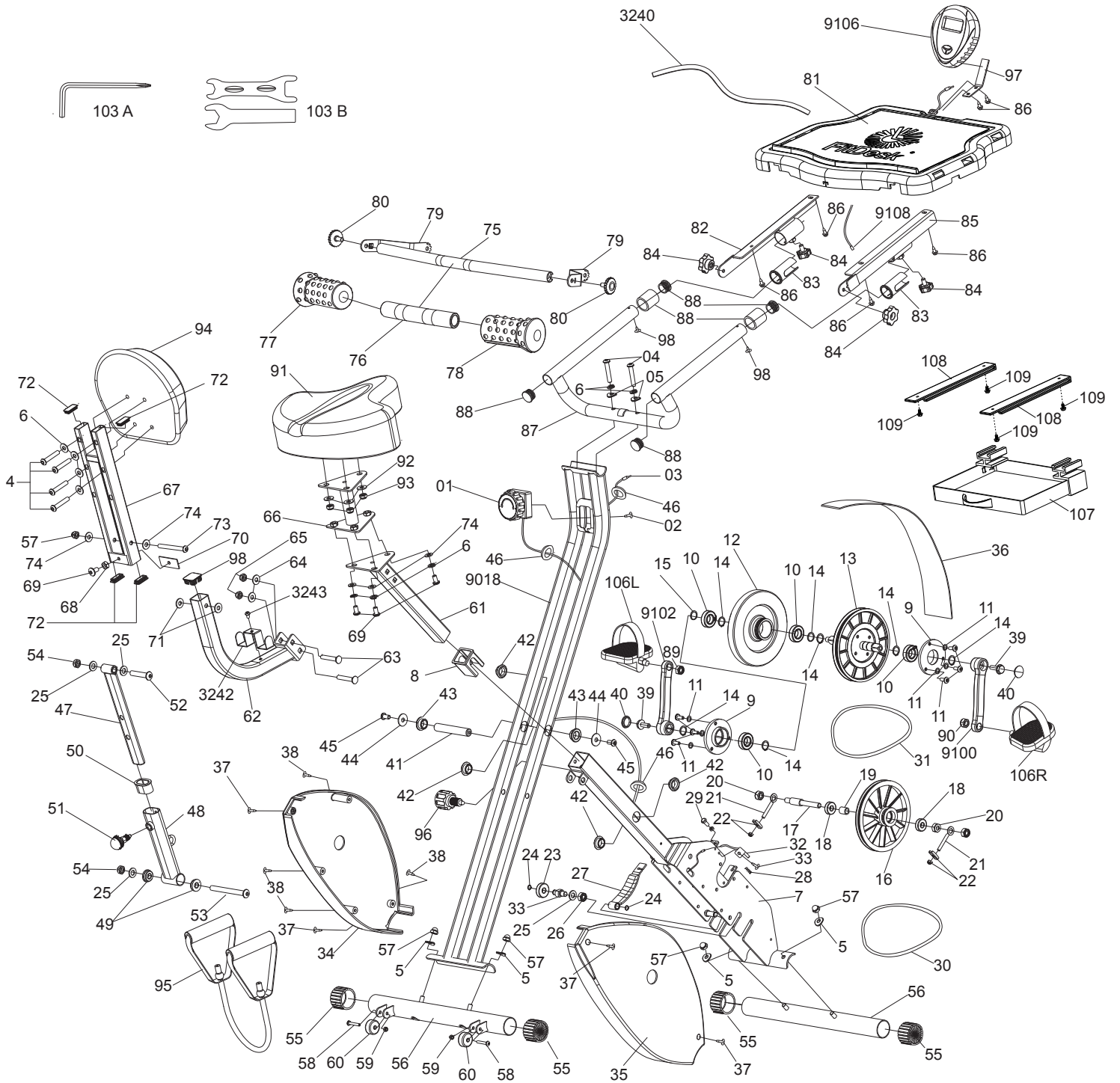

**For Questions or Replacement Parts Contact:
1-855-713-8887**

MONDAY - FRIDAY 9 A.M. - 5 P.M. EST

OPTIONAL ACCESSORIES FOR MODEL: FDX 2.0

OUR MOST POPULAR ACCESSORY

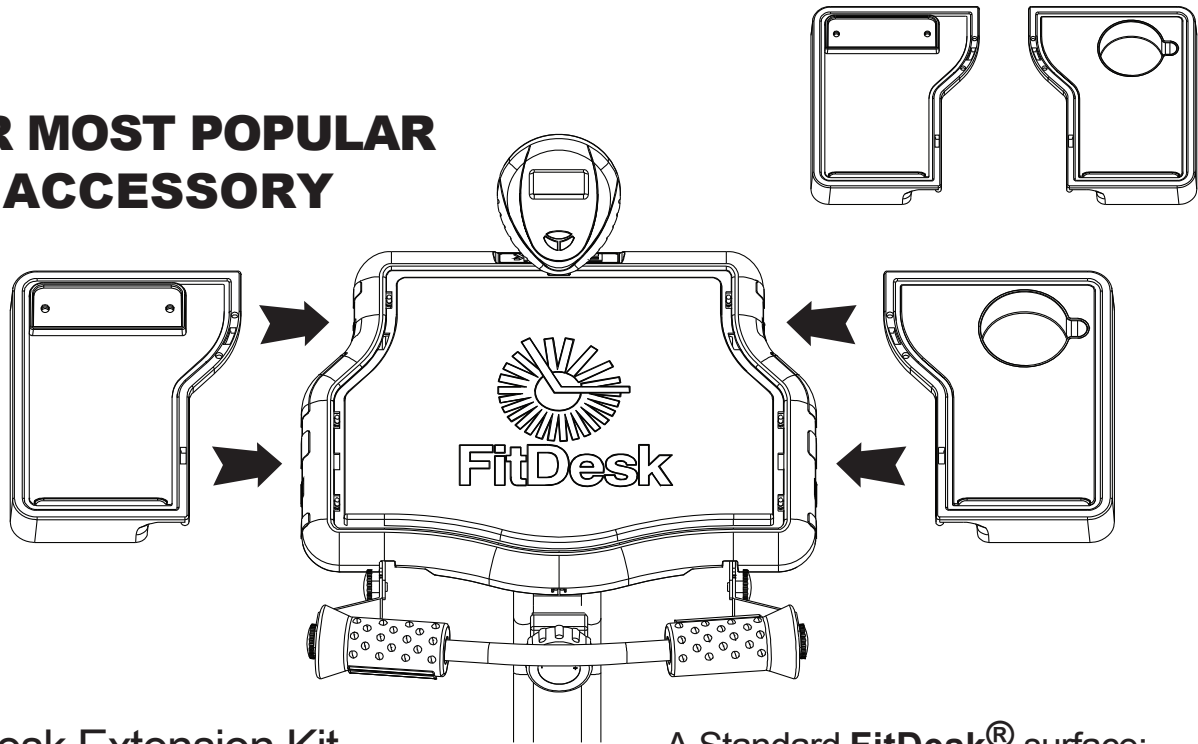

Desk Extension Kit
Includes drink, document holder and mousepad

A Standard **FitDesk®** surface:
20.5" W x 16" D
With extension kit:
31.5" W x 16" D

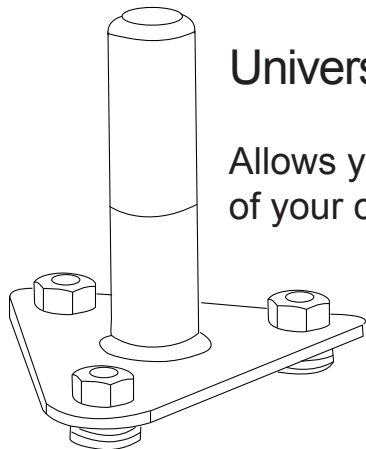

Universal Saddle Adapter

Allows you to use a saddle of your choice on your **FitDesk®**



Water Bottle Holder

To buy these Accessories go to our Website @ www.thefitdesk.com
Products > Accessories & Parts





Where Health and Productivity Converge



[facebook.com / Fitdesk](https://facebook.com/Fitdesk)

FitDesk® is a registered trademark of FD Products LLC. - All Rights Reserved 2017

Updated 8/22/2017