

| ITEM NO. | PART NUMBER | DESCRIPTION                               | QTY. |
|----------|-------------|---|------|
| 1        | 3-049/00    | ASSY. HOSE KIT, HANDSHOWER                | 1    |
| 2        | 6009/00     | ASSY. HANDSHOWER OUTLET SUPPLY AND HOLDER | 1    |
| 3        | P15028/00   | ROUND HANDSHOWER                          | 1    |

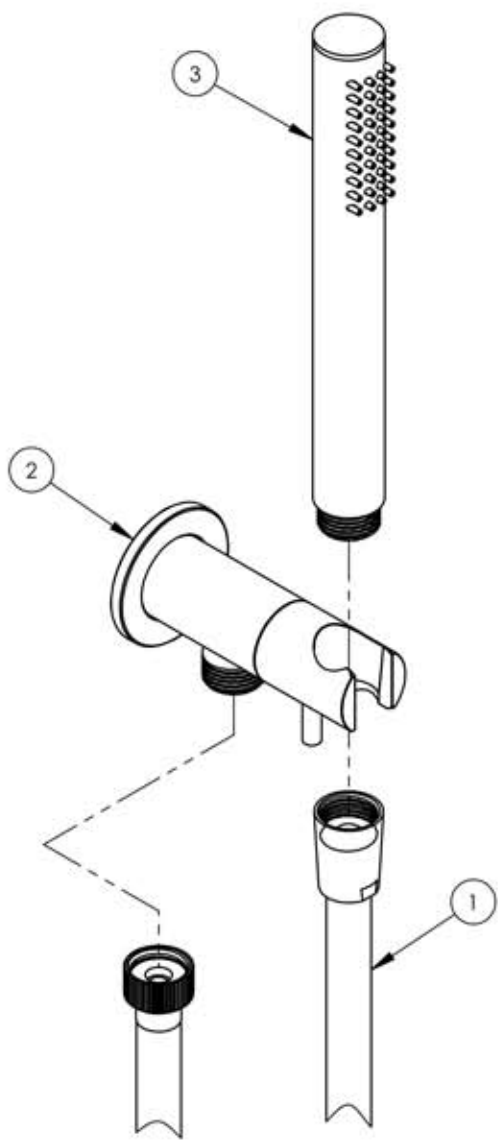

A

B

C

D

E

| ZONE  | REV. | DESCRIPTION | DATE   | APPROVED |
|---|------|-------------|--|----------|
| REVISIONS   |      |             |  |          |
| 1261 LOGAN AVENUE<br>COSTA MESA, CALIFORNIA 92626<br>PHONE: 714.361.4800<br>FAX: 714.617.3120 |      | PHYLTRICH®  | <b>PROPRIETARY AND CONFIDENTIAL</b><br><small>THE INFORMATION CONTAINED IN THIS DRAWING IS THE SOLE PROPERTY OF RSS MANUFACTURING. ANY REPRODUCTION IN PART OR AS A WHOLE WITHOUT THE WRITTEN PERMISSION OF RSS MANUFACTURING IS PROHIBITED.</small> |          |
| Defining Luxury Since 1959  |      |             |  |          |

|                             |         |   |   |                        |
|-----------------------------|---------|---|---|------------------------|
| -                           | -       | INTERPRET GEOMETRIC DIMENSIONING & TOLERANCING IN ACCORDANCE WITH ASME Y14.5-2009 & ASME Y14.41-2003 STANDARDS. UNLESS OTHERWISE SPECIFIED, DIMENSIONS ARE IN INCHES. TOLERANCES ARE: |   |                        |
| NEXT ASSY                   | USED ON | <b>FRACTIONS</b><br>±1/64"  | <b>DECIMALS</b><br>X.X: ±.1<br>X.XX: ±.01<br>X.XXX: ±.005 | <b>ANGULAR</b><br>±.5° |
| APPLICATION                 |         | MATERIAL  | NAME  | DATE                   |
| FINISH                      |         | DRAWN   | LLO   | 3/11/2015              |
| <b>DO NOT SCALE DRAWING</b> |         | CHECKED   | GRE   |                        |

**HAND SHOWER W/VOLUME CONTROL KIT, WALL MOUNT**

|              |              |              |
|--------------|--------------|--------------|
| SIZE         | ASM/PRT NO.  | REV          |
| A            | 4-204/00     | -            |
| SCALE: 1:2.5 | WEIGHT: lbs. | SHEET 1 OF 1 |

5

4

3

2

1