

## Models

KVO-50 KVO-75 KVO-100 KVO-150

## Features

- Rugged and easy to service
- High efficiency
- Quiet, small footprint
- Equipped with NEMA Premium motor
- Easy maintenance and less downtime
- Air-cooled
- Ultimate vacuum for continuous operation of 0.375 Torr (with gas ballast), 0.075 without gas ballast
- Standard gas ballast
- Multistage exhaust filtration system

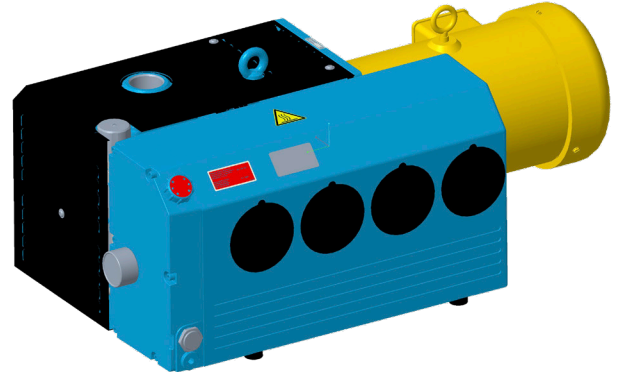

## Specifications

Model	Nominal Displacement	Ultimate Pressure Without Gas Ballast	Ultimate Pressure With Gas Ballast	Motor	Rotation Speed	Oil Capacity	Pump Weight Includes Motor	Noise Level Max
	CFM / m <sup>3</sup> /hr	Torr / mbar	Torr / mbar	60Hz HP / 50Hz kW	60Hz / 50Hz	Gal. / Liters	Lbs. / kg	dB(A)
KVO-50	50Hz 29.4 / 50 60Hz 35.3 / 60	0.075 / 0.1	0.375 / 0.5	2 / 1.5	1740 / 1450	.75 / 2.8	145 / 66	67
KVO-75	50Hz 41.2 / 70 60Hz 49.4 / 84	0.075 / 0.1	0.375 / 0.5	3 / 2.2	1740 / 1450	.75 / 2.8	191 / 87	68
KVO-100	50Hz 58.9 / 100 60Hz 70.6 / 120	0.075 / 0.1	0.375 / 0.5	5 / 3.7	1740 / 1450	.75 / 2.8	256 / 116	69
KVO-150	50Hz 88.3 / 150 60Hz 106 / 180	0.075 / 0.1	0.375 / 0.5	5 / 3.7	1740 / 1450	.875 / 3.3	254 / 115	71

## Typical Pumping Speed Curves NOTE: Curves represented with gas ballast open.

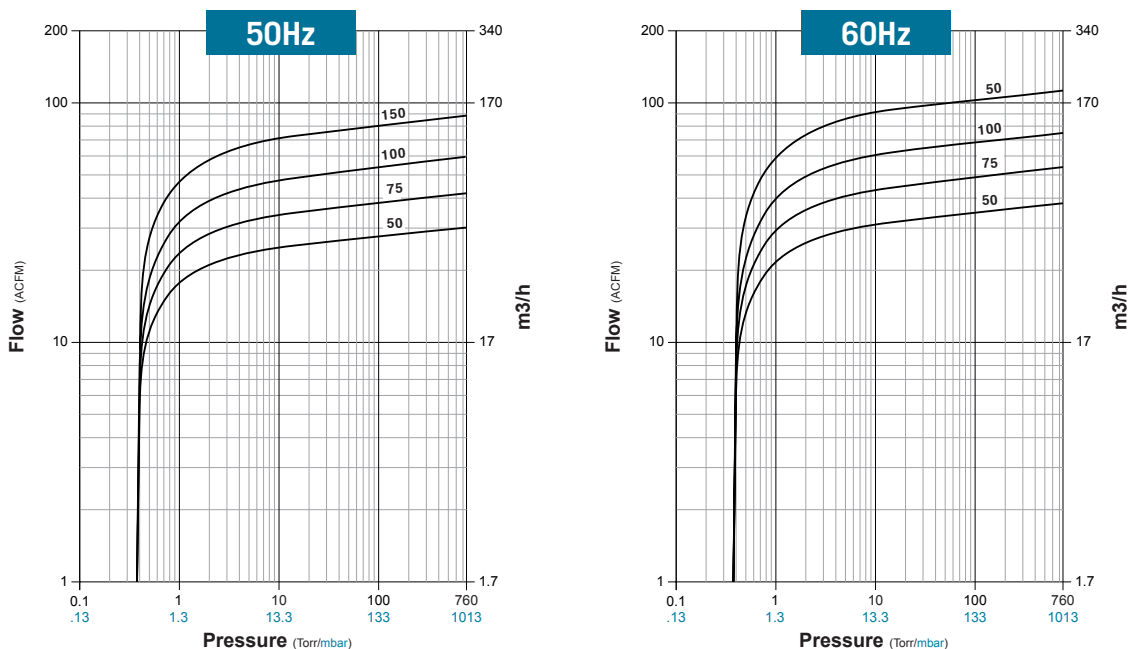

## Dimensions

Values shown are approximate and should not be used for construction.  
 Certified drawings are available through your local Kinney Sales Professional.

## Models KVO-50, KVO-75, KVO-100, KVO-150

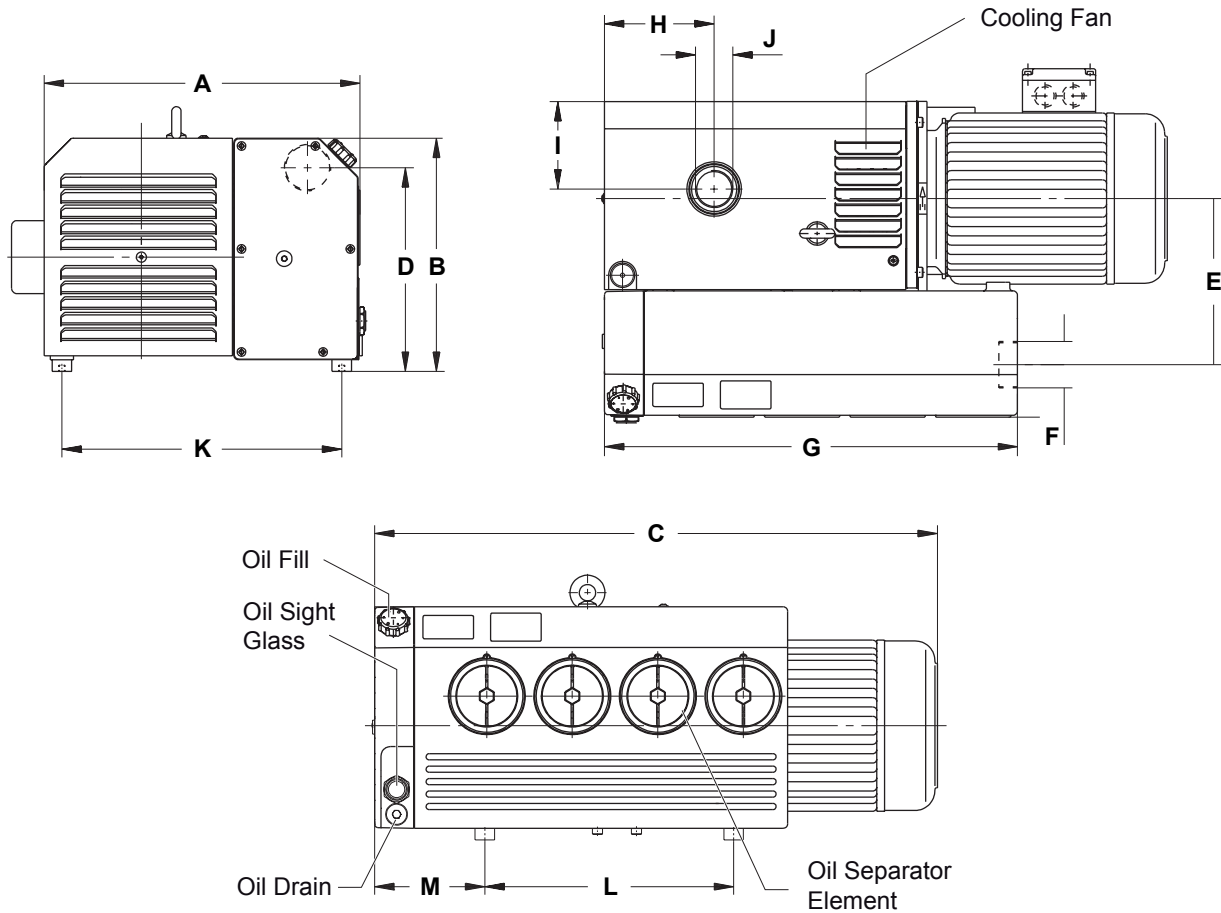

Model	A	B	C	D	E	F - EXHAUST	G	H	I	J - INLET	K	L	M
<b>KVO-50</b> in. / mm	14.48 342	10.55 268	26.04 661	9.53 242	6.56 167	1 ¼" FBSP	21.08 536	5.83 148	3.56 91	1 ¼" FNPT	11.32 288	12.6 320	5.47 139
<b>KVO-75</b> in. / mm	14.48 342	10.55 268	29.03 737	9.53 242	6.56 167	1 ¼" FBSP	21.08 536	5.83 148	3.56 91	1 ¼" FNPT	11.32 288	12.6 320	5.47 139
<b>KVO-100</b> in. / mm	16.23 416	11.73 298	32.93 837	10.2 259	8.43 214	2" FBSP	22.2 564	6.91 176	4.43 113	1 ½" FNPT	14.17 360	12.6 320	6.90 176
<b>KVO-150</b> in. / mm	16.23 416	11.73 298	32.93 837	10.2 259	8.43 214	2" FBSP	22.2 564	6.91 176	4.43 113	1 ½" FNPT	14.17 360	12.6 320	6.90 176

## CONTACT US

For more information, contact your  
 Regional Sales Manager or call us at:

**1-800-825-6937**

Your Local Sales Professional: