



POLARIS+
AIR COMPRESSOR

Delivering What Matters Most

The question isn't "Which compressor can do the job?" Many can perform that basic function. More important is knowing which compressor works reliably longer, even in the most demanding environments. Which saves money by using energy more efficiently. Which is easy to install and use. Which minimizes downtime and the hassle of emergency repairs and ongoing maintenance.

The question is "Which compressor delivers what matters most?"

When you ask the right question, the answer is clear: Polaris+ compressors not only "do the job," they deliver the high quality, efficiency, and ease of operation that make any job more successful.



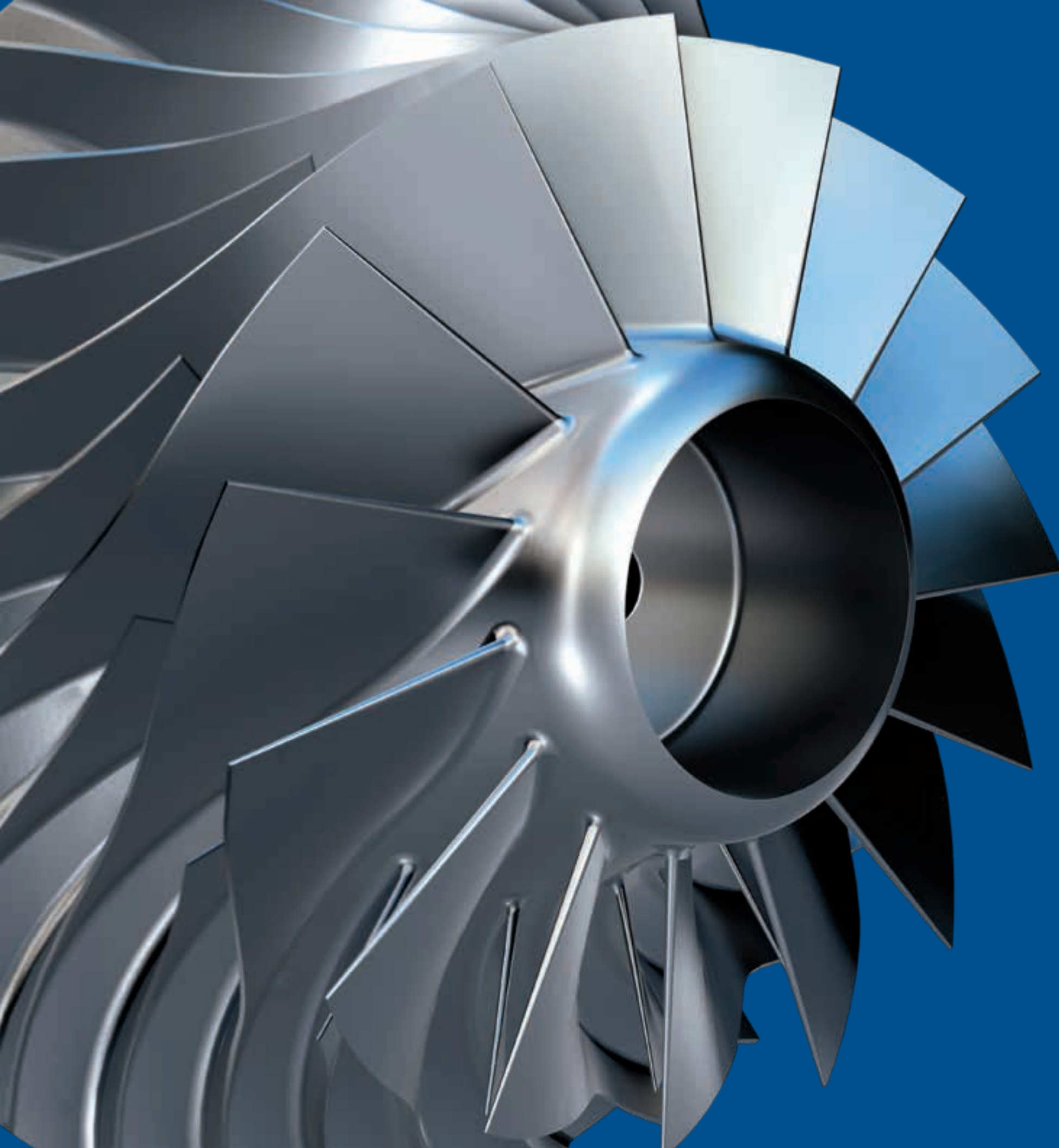

Why Centrifugal?

Efficient aerodynamics make centrifugal compressors ideal for a variety of industrial applications. Centrifugal compressors produce pressure by transferring energy from a rotating impeller to the air. Capacity can be controlled by adjusting the inlet guide vanes—closed to reduce and open to increase flow.

Polaris+ centrifugal compressors feature a simple, effective design that outperforms other compressors in delivering trouble-free operation and the lowest cost of ownership. Polaris+ owners enjoy:

- **Certified ISO 8573-1 Class 0 oil-free air** for purity that meets exacting standards.
- **Low maintenance** with no wearing parts that require regular change-out. Eliminates the need for periodic and expensive air end replacement.
- **Low-to-no vibration** without any special foundation required.
- **Superior control** through a variety of Regulus controller system options.
- **Excellent reliability** over extended periods with minimal maintenance.





A detailed view of the streamlines with velocity vectors between two impeller blades, also in a rotating reference frame, indicates efficient flow from the inducer to the trailing edge, which minimizes parasitic losses and maximizes impeller performance.

Highest Quality

Delivering the most reliable, oil-free air in the industry doesn't happen by chance: it's the result of a rigorous focus on quality from the inside out.

FS-Elliott is committed to building products that will support our customers' high standards. At the heart of the Polaris+ compressor is a technologically advanced, yet beautifully simple, aerodynamic design that builds on the flawless reliability of our custom-engineered PAP Plus product line. Every unit we manufacture is subject to strict quality control at our ISO 9001-certified manufacturing facility to ensure consistent reliability from commissioning through years of demanding use.

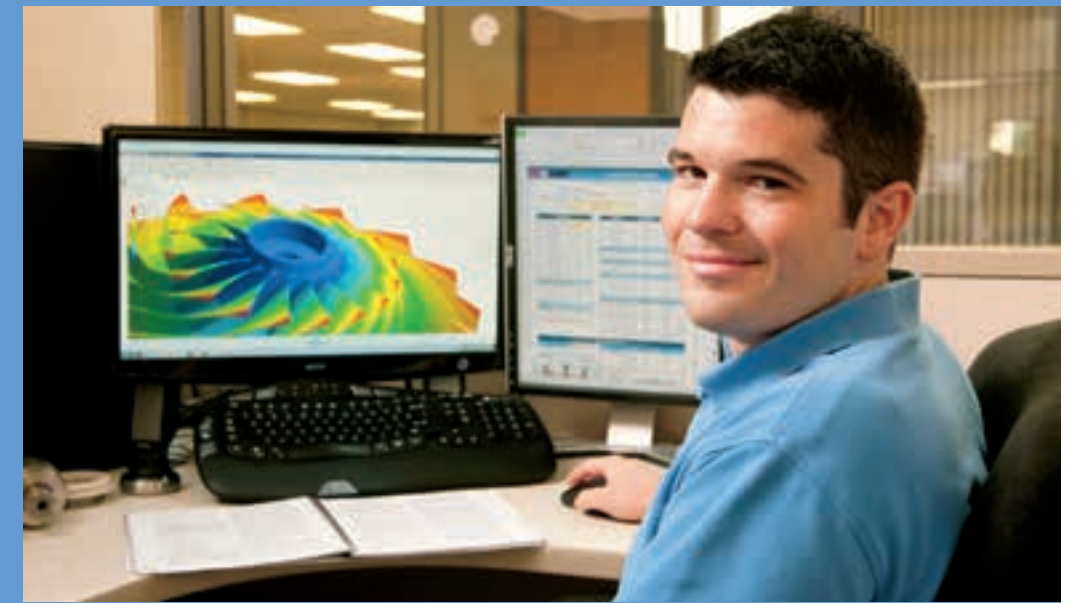

Proactive Control System

The advanced Regulus Control System, standard on every model, offers flexible control to efficiently manage plant load and maximize energy savings.

- Ambient Compensation Control**
 automatically adjusts the compressor surge control line based on changes in ambient conditions, allowing operators to reduce waste by maximizing turndown and minimizing bypass air.
- Integrated Compressor Control**
 automates a lead and lag control process, which provides increased efficiency when operating multiple compressors.
- Pressure Band Optimization**
 assists in avoiding unnecessary discharge air by continually regulating compressor output based on the minimum pressure required to meet system demand.



Efficiency Improvements with ACC & PBO

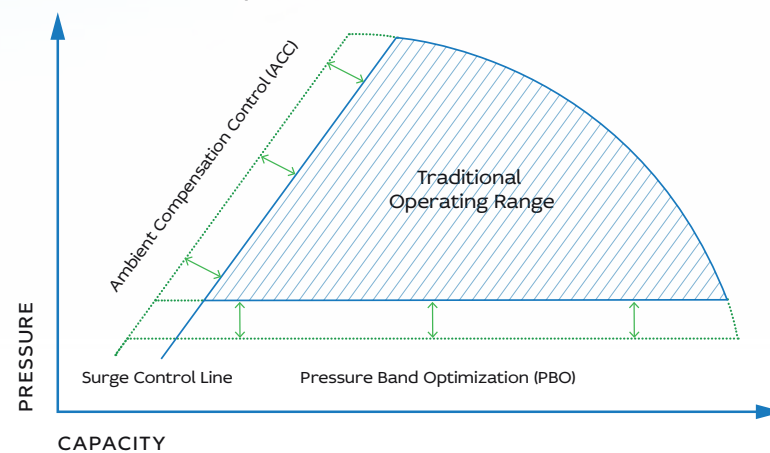

Energy Savings

Any compressor can supply pressurized air. What sets Polaris+ compressors apart is the advanced aerodynamic designs and control systems that enable them to deliver reliable compressed air while minimizing energy and maintenance costs.

Aerodynamic Design and Materials

To reduce power requirements, Polaris+ compressors combine optimized aerodynamic stage matching with intercooler efficiencies. Stainless steel, 5 axis precision-machined impellers resist corrosion, leading to longer life and increased efficiency. Their backward-leaning design can be precisely controlled to optimize both airflow and air compression. We custom-design each impeller using state-of-the-art software to ensure the perfect aerodynamics for your specific application.



Mechanically Superior Bearings

The patent-pending bearings featured on all Polaris+ compressors require less oil consumption and enable operators to reduce power requirements.



Adjustable Inlet Guide Vane

By controlling the amount of air being compressed (and consequently the power consumed), inlet guide vanes efficiently adjust to plant conditions and load variations to conserve energy.



Zero Loss Pulsar™ Drain Valves

Removing condensate from the compressor only when needed, rather than constantly, eliminates wasting compressed air—and the energy needed to produce it.



Ease of Ownership

No matter how well a compressor performs, if it's difficult to install, commission, and maintain, why own it? Polaris+ compressors are built to be easy to own and operate, year after year.

Installation Ease

By packaging key components and accessories—including the aftercooler, water manifold, and lube system—Polaris+ compressors reduce site preparation time and costs, making installation easier.

Operation Ease

The new ergonomically designed 9" full touch-screen control display comes standard on all Polaris+ compressors, and brings compressor control into the tablet era. Navigating the control system is an intuitive experience that simulates application-based computing.

Maintenance Ease

Polaris+ compressors combine several features that allow them to operate reliably for extended periods with minimal maintenance.

- **Horizontally split gear case and internal components** are integral features of the only truly field-serviceable gear box in the industry.
- **Straight-through intercooler tube** accommodates periodic cleaning, rather than replacement.
- **Full-capacity auxiliary oil pump** continues normal, safe operation in the event of a main oil pump failure.
- **Engineered coatings designed for extreme conditions** provide extended service life of internal and external surfaces, reduced maintenance, and corrosion prevention.
- **Corona™ brand lubricants** last longer and provide excellent wear protection. By minimizing harmful build-up, they also ensure longer equipment operating cycles.
- **Trained local distribution network** offers expert repair and maintenance services on demand 24/7/365.

Specializing in centrifugal technology provides us the resources and experience to constantly improve our product offerings. The Polaris+ product line refresh includes several new features included as standard options. Designed to improve efficiency, increase reliability, and enhance the overall user experience, the new features of the Polaris+ line of compressors include:

- **R1000 Control System**, featuring a 9-inch full touch-screen display, introduces several new control modes to provide increased energy efficiency.
- **Engineered coatings** that deliver extended service life, reduce maintenance, and prevent corrosion.
- **Mechanically superior, patent-pending bearings** that result in improved stability, require less oil consumption, and reduce power requirements.
- **Consolidated package upgrades**, providing increased package flexibility, additional future upgrade consideration, and extended product life.
- **Advanced aerodynamic staging** that reduces power consumption.

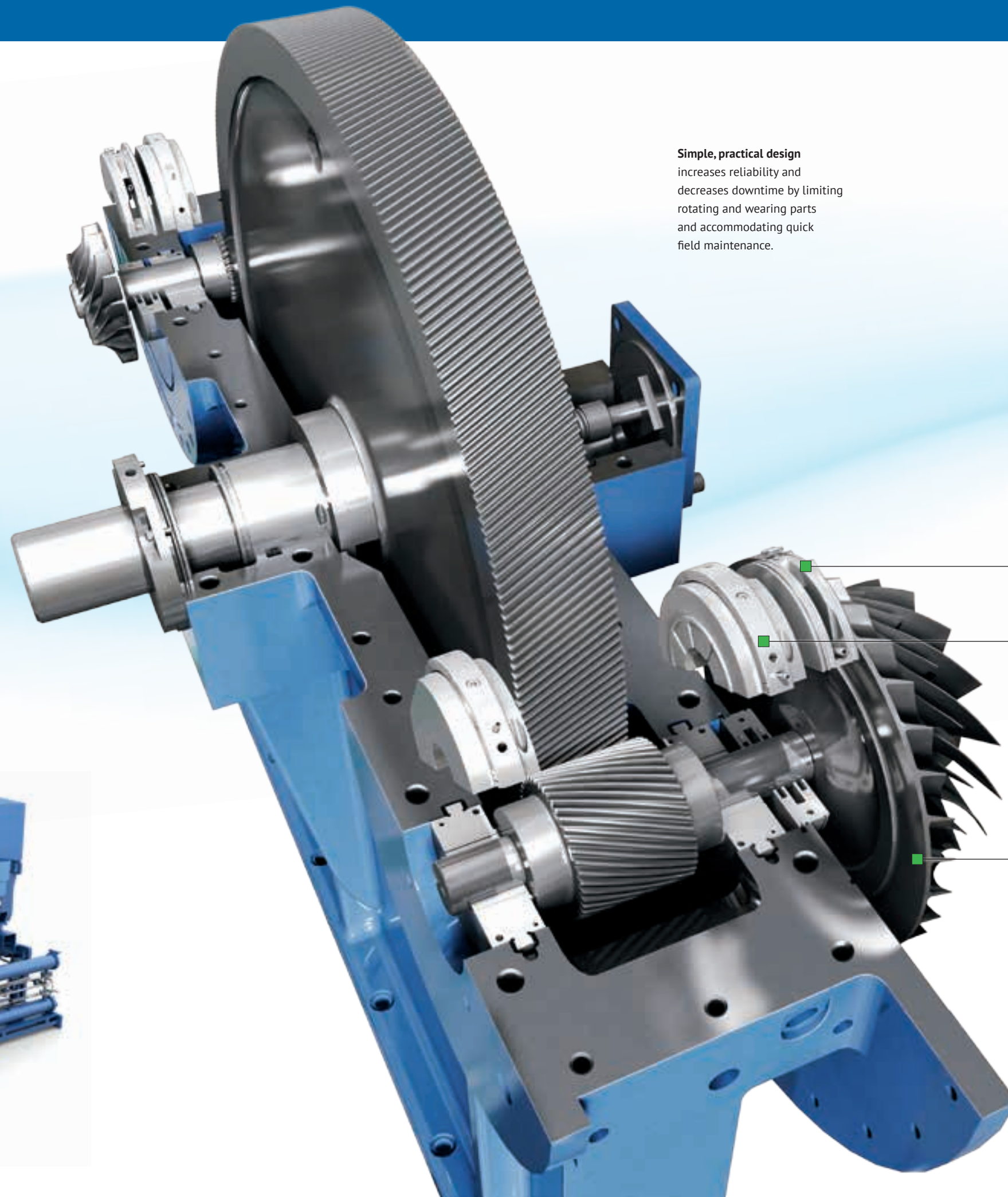

Simple, practical design increases reliability and decreases downtime by limiting rotating and wearing parts and accommodating quick field maintenance.

Horizontally split bearing and seal design allows for easy inspection and maintenance.



Seal

Bearing

Aerodynamic design of the stainless steel, 5 axis precision-machined impellers optimizes airflow and provides highly efficient air compression.

Polaris+ compressors combine 50 years of operational and design experience in an extremely reliable, energy-efficient, cost-effective package. They suit a broad range of applications, with models ranging from 250 hp to 2,500 hp in two- and three-stage configurations that deliver up to 150 psig (10.5 BARG) discharge pressure.

Polaris+ Model	Overall Dimensions						Approximate Weight*	
	A*		B*		C*		lb.	kg
	in.	mm	in.	mm	in.	mm		
P300+	115	2910	101	2568	72	1832	10000	4550
P400+	143	3632	75	1905	81	2057	14500	6575
P500+	125	3175	85	2160	85	2160	16000	7260
P600+	159	4040	87	2208	88	2238	13500	6222
P700+	181	4597	92	2337	87	2210	28800	13063

* Value may vary with motor rating and type

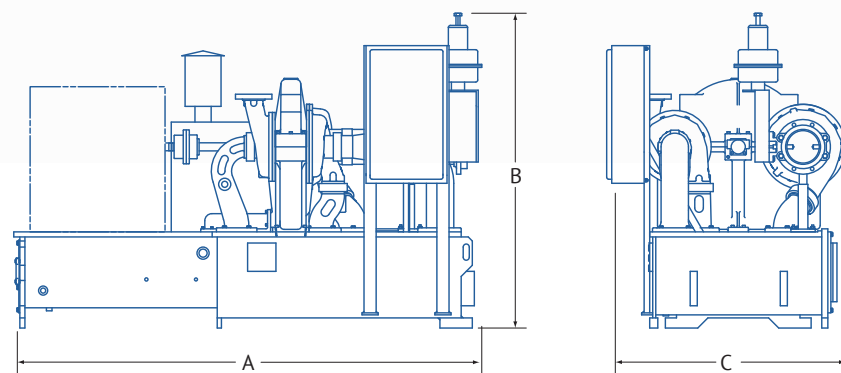

Discharge Pressure
45 to 150 psig/3.1 to 10.3 BARG
 Performance may vary based on actual site conditions. Consult your authorized FS-Elliott distributor for more information.



900 ICFM / 25 m³/min
 250 HP / 186 kW

1600 ICFM / 45 m³/min
 400 HP / 298 kW

2090 ICFM / 59 m³/min
 450 HP / 336 kW

2600 ICFM / 74 m³/min
 600 HP / 447 kW

3350 ICFM / 95 m³/min
 700 HP / 522 kW

4000 ICFM / 113 m³/min
 700 HP / 522 kW

4500 ICFM / 127 m³/min
 1000 HP / 746 kW

6000 ICFM / 170 m³/min
 1250 HP / 932 kW

6500 ICFM / 184 m³/min
 1500 HP / 1119 kW

11500 ICFM / 326 m³/min
 2500 HP / 1864 kW



P300+



P400+



P500+



P600+



P700+



Sound Enclosures
Modular enclosures accommodate installation sites that have special acoustic requirements. A rigid base frame provides a stable foundation, while side and roof panels are removable for easy access during routine maintenance and handling.



Motor Starters
Choose from a full line of motor starters to suit your needs. Certain models include an option to mount the starter on the unit.



Regulus Control Systems
The standard 9" full touch-screen display allows you to easily monitor and manage the performance of one or multiple compressors, at the unit or remotely, to meet air demands while maximizing energy savings.



Dual Oil Filters With Integral Transfer Valve
When continuous operation is essential and shutdowns for routine maintenance are unacceptable, opt for the dual filter and transfer valve configuration. It allows the compressor to continue to operate while switching smoothly from one filter element to the other.



Zero Loss Pulsar™ Drain Valve
By discharging condensate only when its reservoir is full, this energy-saving valve eliminates water without unnecessarily losing air. It is simple to install, intuitive, and features compact, rugged construction. Various configurations are available for installation.



Corona™ Lubricants
Our exclusive line of lubricants minimizes harmful build-up to maximize equipment operating cycles. Exclusive use of Corona lubricants makes your compressor eligible for the FS-Elliott Extended Warranty Program, adding peace of mind and reducing long-term cost of ownership.



Aries™ Dryers

To maintain optimum low dewpoints and high air cleanliness, Aries desiccant dryers are ideal. Their extremely low maintenance design (only one moving valve part) both minimizes pressure drop and extends the life of the desiccant.





Parts

Our extensive inventory of quality OEM parts gives you immediate access to the service parts you need. We can provide parts to meet exacting dimensions, material specifications, and the latest technology. Most parts can be shipped directly to you within 24 hours.

Installation and Start-up

Working with our distributors, we tailor installation and start-up services to meet your needs. From providing qualified assistance to your commissioning team to delivering a total turnkey installation, we will help you get up and running quickly and efficiently.

Repairs

Our compressors are designed for complete field servicing. FS-Elliott's factory-authorized distributor service teams are available to perform a variety of repair services at your facility. Whether a simple oil change or a complete overhaul, no job is too big or too small. Emergency situations are handled with urgency 24/7/365.

Maintenance

Polaris+ compressors combine several features that ensure reliable operation over extended periods with minimal maintenance:

- Inherently low vibration
- No rubbing or direct wearing parts
- Optimum clearances between rotating and stationary parts
- No oscillating load
- Integrated package to simplify installation and ongoing use

Rerates

Rerating an existing compressor is the most efficient way to meet the changing demands of your compressed air system. By implementing design innovations and upgrades to match current needs, you can improve reliability and reduce lifecycle costs. Given today's rising energy costs, rerates can generate very fast returns.

Training

We offer a wide range of operator and maintenance training programs, including standard, self-contained packages and customized sessions to fit your needs. Training can be delivered at your facility or one of ours.



Headquarters—Export, Pennsylvania, USA

Basingstoke, United Kingdom
Houston, Texas, USA
Jubail, Kingdom of Saudi Arabia
Los Angeles, California, USA
Bangalore, India
Kuala Lumpur, Malaysia
Shanghai, China
Taipei, Taiwan

Building on a 50-year tradition of excellence in compressor design and manufacturing, FS-Elliott brings our customers the resources of a global industry leader along with the convenience and responsiveness of local sales and service. Thousands of reliable, hard-working FS-Elliott compressors are installed worldwide.

FS-Elliott Co., LLC

5710 Mellon Road
Export, PA 15632-8948, USA
+1.724.387.3200 tel
+1.724.387.3270 fax
info@fs-elliott.com email
www.fs-elliott.com

Represented by:



ISO 9001- certified
for the design
and manufacture
of centrifugal
compressors.

FS-Elliott Co., LLC reserves the right to modify the design or construction of the equipment described in this brochure and to furnish it, as altered, without further reference to the illustrations or information contained herein.