



H Series High Efficiency Coalescing Filters



ENGINEERING YOUR SUCCESS.



Why Filter Compressed Air?

Product rejects and increased maintenance expenses can occur due to poor air quality

Submicronic contaminants in compressed air systems plug orifices of sensitive pneumatic instrumentation, wear out seals, erode system components, reduce the absorptive capacity of desiccant air/gas dehydrators, foul heat transfer surfaces, reduce air tool efficiency, and damage finished products. The results include product rejects, lost production time and increased maintenance expense. For example, trace amounts of submicronic oil can cause serious fish eye blemishing in automotive finishing operations. Water left in air lines can freeze during exposure to cold temperatures, blocking flow or rupturing pipes. Compressor lubricant not captured in a coalescing filter will eventually collect in pneumatic components, causing premature component repair or replacement. Environmental concerns will be raised if oily, compressed air is continually discharged into the atmosphere through a pneumatic muffler.

Finite's H-Series Offers

- Coalescing, particulate and adsorption filter elements
- Optional indicators, gauges and drains
- Temperatures to 450° F (232° C)
- Pressures to 500 PSIG (34 bar)
- Connection sizes from 1/4" to 3" NPT, BSPP & BSPT
- Flows from 10 to 1660 SCFM (17-2822 m³/hr)

Why Use Finite Filters?

Element formation

Our special UNI-CAST formed elements provide lower pressure drop and less frequent changeouts, saving you time and money.

We meet your needs

Finite offers a variety of filter elements to meet your application requirements.

Technical support

We are committed to providing unmatched technical support to all of our customers.

Short lead times

Our LEAN manufacturing capability assures that you will have the right filter product at the right time. Popular products are shipped in three days.

Manufacturing plants use compressed air in a variety of automated processes.



Typical Applications

(See Pages 4-5 for application and air cleanliness schematics)

Coalescing (Oil Removal)

- Air dryer prefilter
- Paint spray booths
- Breathing air
- Tool protection
- Air valve protection
- Air cylinder protection
- Natural gas filtration
- Technical gas filtration

Interceptor (Particulate Removal)

- Desiccant dryer afterfilter
- Prefilter for coalescer
- Systems with high concentrations of solid contaminant
- Particulate protection for non-lubricated systems

Adsorber (Vapor Removal)

- Odor removal
- Breathing air
- Food packaging equipment
- High purity laboratory gases
- Hydrocarbon vapor removal

Sources of Contamination

Compressed air and gas lines typically contain water, oil, and particulate contamination

The contaminants of greatest concern in precision compressed air systems are water, oil, and solids. Water vapor is present in all compressed air and it becomes greatly concentrated by the compression process. While air dryer systems can be used effectively to remove water from compressed air, they will not remove the second major liquid contaminant – oil.

Most oil comes from compressor lubrication carry-over, but even the air produced by oil-free compressors has hydrocarbon contamination brought into the system through the intake.

The third contaminant is solid matter including dirt, rust, and scale. Solid particulates, combined with aerosols of water and oil, can clog and shorten the life of air system components and can foul processes.

Four steps to clean, dry compressed air and gas.

Determine your application, media grade, media type and end seal material.
Pages 4-7

1

Choose your housing and replacement elements.
Pages 8-9

2

Choose your accessories. Find out what's standard or choose what's best for your application.
Page 9

3

How to Order. Build your own part number here!
Page 10

4

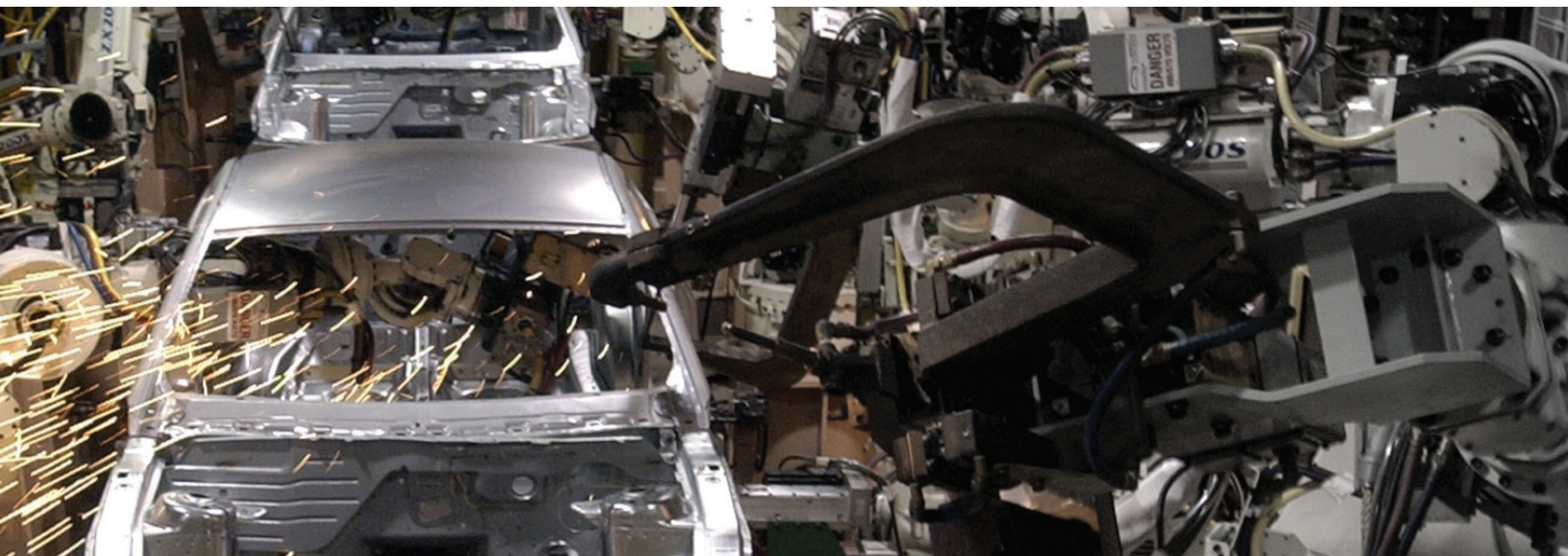



Compressed Air Standards and Applications

From aeration in pharmaceutical and chemical processes to pneumatic power systems, the possibilities for applications are endless. Finite has some suggested air cleanliness standards that may fit your needs.

International Standard ISO8573-1 has become the industry standard method for specifying compressed air cleanliness. The following diagrams describe various systems in terms of their corresponding ISO classification.

Notification as specified in ISO8573 - 1 (1991)							
Class	Maximum Particle Size	Solid		Water		Oil	
		Maximum Concentration*		Maximum Pressure Dewpoint		Maximum Concentration*	
		(µm)	ppm	mg/m ³	°F	°C	ppm
1	0.1	0.08	(0.1)	-94	(-70)	0.008	(0.01)
2	1	0.8	(1)	-40	(-40)	0.08	(0.1)
3	5	4.2	(5)	-4	(-20)	0.83	(1)
4	15	6.7	(8)	37	(+3)	4.2	(5)
5	40	8.3	(10)	45	(+7)	21	(25)
6	-	-	-	50	(+10)	-	-

*At 14.7 psi (1 bar) absolute pressure, +70°F (+20°C) and a relative humidity of 60%.

- It should be noted that at pressures above atmospheric, the contaminant concentration is higher.
- The quality of the air delivered by non-lubricated compressors is influenced by the quality of the intake air and the compressor design.

ISO Class 2 3

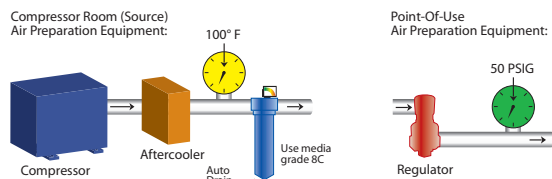

Any compressor with aftercooler. Air intended for use with lubricated air tools, air motors, cylinders, shot blasting, non-frictional valves.

OTHER SPECS MET: Compressed Air & Gas Institute: CGA – G7.1 (Grades A & Ba1)

ISO Class 1 1

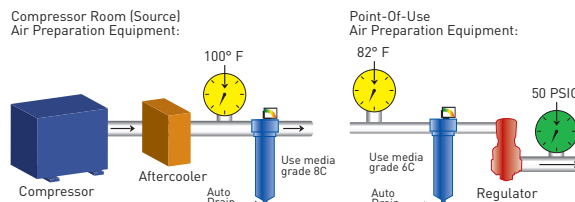

Any compressor with aftercooler and 2-stage coalescing. Air intended for use with lubricated control valves, cylinders, parts blow-down, etc.

OTHER SPECS MET: Mil. Std. 282 H.E.P.A., U.S.P.H.S. 3A Accepted particles for milk

ISO Class 1 1

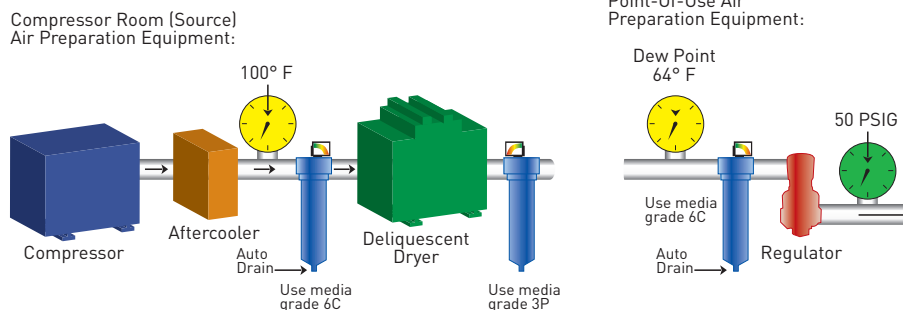

Any compressor with aftercooler, 2-stage coalescing and deliquescent dryer. Air intended for use with general pneumatic systems, body shop spray painting and components sensitive to high moisture content.

OTHER SPECS MET: Compressed Air & Gas Institute: CGA – G7.1 (Grade C)



ISO Class 1 4 1

Compressor Room (Source)
Air Preparation Equipment

Point-Of-Use
Air Preparation Equipment

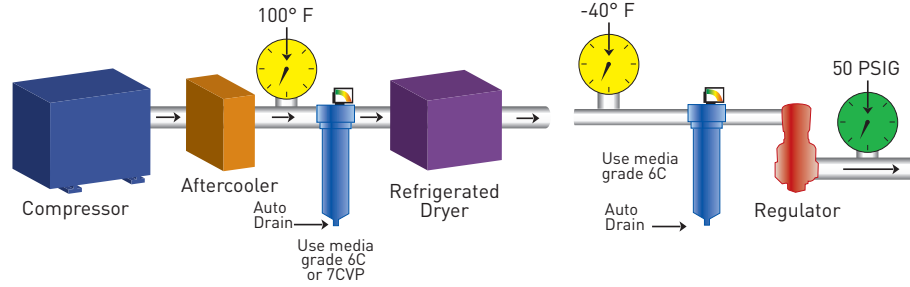

Any compressor with aftercooler, 2-stage coalescing and refrigerated dryer. Air intended for use with air-gauging, air conveyors, spray-painting, food processing,

instrumentation, blow molding, cosmetics, film processing, bottling, pharmaceuticals, dairy, breweries, medical, robotics, and close tolerance valves.

SPECS MET: CGA – G7.1 (Grades D & E), ISAS7.3 Fed. Std. 209 (Class 100)

ISO Class 1 4 1

Compressor Room (Source)
Air Preparation Equipment:

Point-Of-Use
Air Preparation Equipment:

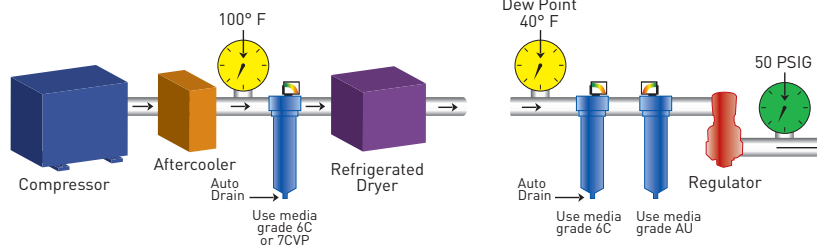

Any compressor with aftercooler, 2-stage coalescing, refrigerated dryer and carbon absorber. Air intended for use as industrial breathing air and decompression chambers.

CAUTION: Always use high temperature synthetic lubricants and monitor (alarm for carbon monoxide concentrations). This system will not eliminate toxic gases!

OTHER SPECS MET: O.S.H.A. 29CFR 1910.134

ISO Class 1 2 1

Compressor Room (Source)
Air Preparation Equipment:

Point-Of-Use
Air Preparation Equipment:

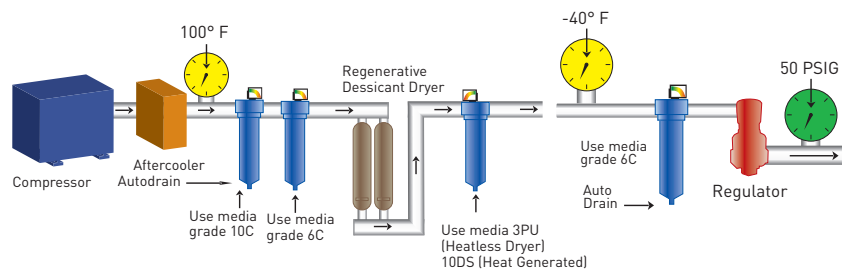

Any compressor with aftercooler, two-stage and double coalescing and a regenerative-type desiccant dryer. Air intended for use in applications involving rapid expansion

of compressed air, critical instrumentation, high purity gases, computer chip drying, etc. CAUTION: This air is too dry for respiratory use.

SPECS MET: CGA – G7.1 (Grade F)

1

Determine your application, media grade, type, and end seals.

Find your (or similar) application from the descriptions below, from the basic application circuits on the previous page, or consult a Finite application engineer. Determine media grade, media type, and end seal required. If your application requires a coalescing element, use the information listed below. For other media types, please see the following page.



Coalescing Elements (removal of liquids and particulate)



Media type C

Available in grades 4, 6, 8, or 10
Air Flow: Inside to Outside

This coalescing element is made with our special UNI-CAST construction. Composed of an epoxy saturated, borosilicate glass micro-fiber media, this media is used in applications requiring the removal of liquid and particulate contamination. The outer synthetic fabric layer allows swift removal of coalesced liquids.

Media type I is constructed similarly to the C media but also includes an inner retainer intended for additional strength where reverse flow is likely.

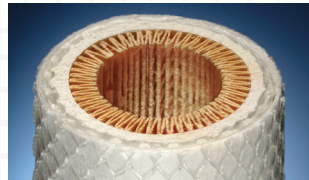

Media type Q

Available in grades 4, 6, 8, or 10
Air Flow: Inside to Outside

This coalescing element is composed of an epoxy saturated, borosilicate glass micro-fiber media, and is also made with our special UNI-CAST construction. This media type has a built-in pleated cellulose prefilter as the inner layer. As with the C and I media types, the outer synthetic fabric layer aids in the swift and efficient removal of coalesced liquids.

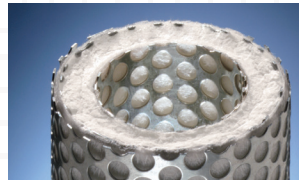

Media type D

Available in grades 4, 6, 8, or 10
Air Flow: Inside to Outside

Media type D elements are composed of a micro-glass coalescer, utilize a special high temperature UNI-CAST formulation, but are surrounded by inner and outer diameter metal retainers. These metal retainers, coupled with a glass drain layer, make this an extremely robust element designed to remove both solid and liquid contaminants at elevated temperatures.

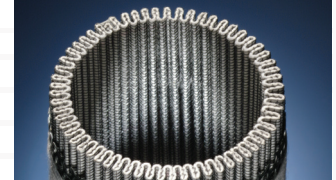

Media type 7CVP or ME

Air Flow: Inside to Outside

Finite's 7CVP media type consists of two filter layers between metal retainers. The outer layer removes aerosols while the inner layer traps solid particles, protecting and extending the life of the outer layer. 7CVP elements are used in bulk liquid coalescing applications or when relatively high efficiency and low pressure drop are required. A special 7DVP media is constructed the same way, however it allows for higher temperature applications.

Finite's ME media type are mist eliminator elements that are constructed similarly to the 7CVP, but offer even higher filtration efficiency for more critical compressed air quality demands.

Only available in 1¼" NPT port size housings and larger

For types C, D, I and Q - Choose your grade

Grade 4

Finite's media grade 4 is typically chosen when an extremely high coalescing efficiency is required. Its 99.995% rating is the best available and is ideal for use as a final filter in applications with elevated operating pressures (up to 500 PSIG), or when removing liquid contaminants from gases lighter than compressed air.

Grade 6 (Standard)

Grade 6 filters are used when "total removal of liquid aerosols and suspended fines" is required. Because of its overall performance characteristics, this grade is most often recommended in a variety of industrial applications. Grade 6 is an excellent choice as a prefilter for regenerative desiccant air dryers, as it prevents oil or varnish from coating the desiccant.

Grade 8

Grade 8 filters combine high efficiency (98.5%) with high flow rate and long element life. A separate prefilter is not required for "normal to light" particulate loading. A grade 8 element is often chosen as protection for refrigerated air dryers. This element allows the dryer to maintain efficiency by preventing the coating of copper coils with the build-up of oil or varnish.

Grade 10

Grade 10 filters are used as prefilters for grades 6 or 8 to remove gross amounts of liquid aerosols or tenacious aerosols. Grade 10 is often referred to as a coarse coalescer, or precoalescer. A grade 10 in a media type D filter element is recommended as an afterfilter for heat regenerated desiccant type air dryers as its one micron rating is ideal for collecting air dryer desiccant fines before they pass downstream.



Water Separator Element (removal of bulk liquids)

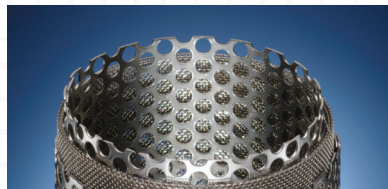

Media type 100WS

Air Flow: Inside to Outside

This rolled stainless steel mesh element has ID and OD metal retainers with rolled stainless steel mesh in between. It is an extremely robust design. With a nominal rating of 100 micron, this media is used for the reduction and elimination of excess liquids in gas streams. It also would be a good choice as a prefilter for coalescing grades 6 and 10 when extreme volumes of liquid contaminants are present.

Interceptor Element (removal of solids)



Media type 3P

Air Flow: Outside to Inside

Finite's 3P pleated cellulose element removes solid contaminants, with a 3 micron absolute rating. Because this element is designed to flow from its outside to the inside, it has a strong inner retainer that gives this element added strength. 3P particulate "Interceptor" elements are used where very high dirt loading is expected but a relatively fine pore structure is required. It is also used as a prefilter to a coalescing filter in systems where a lot of solid contamination exists.

Adsorption Element (removal of odor)



Media type A

Air Flow: Outside to Inside

This hydrocarbon vapor removal element consists of an ultra-fine grained, highly concentrated, activated carbon sheet media. Because these elements are designed to flow from the outside to their inside, they have a strong inner retainer giving this element added strength. This media type is used to remove hydrocarbon vapor and is often used to remove the smell or taste of compressor lube oil from breathing air.

Finite Media Specifications

Grade Designation	Coalescing Efficiency 0.3 to 0.6 Micron Particles	Maximum Oil Carryover ¹ PPM w/w	Micron Rating	Pressure Drop (PSID) @ Rated Flow ²	
				Media Dry	Media Wet With 10-20 wt. oil
4	99.995%	0.003	0.01	1.25	3-4
6	99.97%	0.008	0.01	1.0	2-3
ME	99.95%	0.02	0.3	0.5	1.0
7	99.5%	0.09	0.5	0.25	0.5-0.7
8	98.5%	0.2	0.5	0.5	1-1.5
10	95%	0.85	1.0	0.5	0.5
100WS	99+ ³	N/A	100	<0.25	<0.25
3P	N/A	N/A	3.0	0.25	N/A
A	99+ ⁴	N/A	3.0	1.0	N/A

1. Tested per ISO 12500-1 at 40 ppm inlet.
2. Add dry + wet for total pressure drop.
3. Bulk liquid removal efficiency.
4. Oil vapor removal efficiency is given for A media.

End Seals available

End Seals	Available on Media type	Max temp of element with end seal
No end seals. Element are self sealing.	C	175°F (79°C)
U: Molded Urethane (standard)	C	175°F (79°C)
	I	
	Q	
	3P	
	100WS	
S: Molded Silicone Rubber	C	175°F (79°C)
	Q	175°F (79°C)
	D	450°F (232°C)
	3P	350°F (177°C)
V: Fluorocarbon gaskets on metal end caps	C	350°F (177°C)
	Q	350°F (177°C)
	D	450°F (232°C)
Note: V option is only available on 1¼" NPT and larger. Standard on all 7CVP, 7DVP, ME and 100WS media.	ME	175°F (79°C)
	7CVP	175°F (79°C)
	7DVP	400°F (204°C)
	100WS	450°F (232°C)
	3P	350°F (177°C)
	A	175°F (79°C)

2

Determine your housing

Find your desired flow rate under the appropriate media grade column. For pressures other than 100 PSIG or temperatures other than 70°F, please see Alternate Housing Selection Chart, Step 2a, on following page.

Housing Selection Chart

Rated Flows: SCFM @ 100 PSIG (m³/hr @ 7 bar)
For other pressures, please see Step 2a on following page.

Note: The housing assembly part numbers below have a NPT connection. For BSPP, insert F in place of N. For BSPT, insert T in place of N.

Housing Assembly	Port Size	Grade 4 Coalescer	Grade 6 Coalescer (Standard)	Grade 7CVP Coalescer (or ME Media)	Grade 8 Coalescer	Grade 10 Coalescer	Grade 3PU Interceptor	Grade 100WS Water Separator	Grade A Adsorber
HN1S	1/4"	11 (19)	15 (26)	N/A	20 (34)	25 (43)	25 (43)	50 (85)	15 (26)
HN15S	3/8"	15 (26)	20 (34)	N/A	27 (46)	33 (56)	33 (56)	66 (112)	20 (34)
HN2S	1/2"	19 (32)	25 (43)	N/A	34 (58)	42 (71)	42 (71)	83 (141)	25 (43)
HN1L	1/4"	23 (39)	30 (51)	N/A	41 (68)	50 (85)	50 (85)	50 (85)	30 (51)
HN15L	3/8"	30 (51)	40 (68)	N/A	55 (94)	66 (112)	66 (112)	66 (112)	40 (68)
HN2L	1/2"	38 (65)	50 (85)	N/A	68 (116)	83 (141)	83 (141)	83 (141)	50 (85)
HN3S	3/4"	61 (104)	80 (136)	N/A	109 (185)	133 (226)	133 (226)	133 (226)	80 (136)
HN4S	1"	76 (129)	100 (170)	N/A	136 (231)	166 (282)	166 (282)	232 (394)	100 (170)
HN4L	1"	106 (180)	140 (238)	N/A	191 (325)	232 (394)	232 (394)	232 (394)	140 (238)
HN5S	1 1/4"	190 (323)	250 (425)	415 (706)	330 (461)	415 (706)	415 (706)	415 (706)	250 (425)
HN6S	1 1/2"	260 (442)	350 (595)	600 (1020)	465 (791)	600 (1020)	600 (1020)	600 (1020)	350 (595)
HN8E	2"	260 (442)	350 (595)	600 (1020)	465 (791)	600 (1020)	600 (1020)	600 (1020)	350 (595)
HN8S	2"	340 (578)	450 (765)	750 (1275)	600 (1020)	750 (1275)	750 (1275)	750 (1275)	450 (765)
HN8L	2"	470 (799)	625 (1063)	1035 (1760)	830 (1411)	1035 (1760)	1035 (1760)	1035 (1760)	625 (1063)
HN0L	2 1/2"	600 (1020)	800 (1360)	1330 (2261)	1060 (1802)	1330 (2261)	1330 (2261)	1330 (2261)	800 (1360)
HN12L	3"	750 (1275)	1000 (1700)	1660 (2822)	1330 (2261)	1660 (2822)	1660 (2822)	1660 (2822)	1000 (1700)

Replacement Element Part Numbers

*Insert selected media grade 4, 6, 8, 10.

Housing Assembly	Coalescer	Coalescer w/inner retainer	High Temperature	Coalescer w/ built-in prefilter	ME Mist Eliminator	7CVP Pleated Coalescer	3PU Interceptor	100WS Water Separator	AU Adsorber
HN1S	*C10-025	*IU10-025	*DS10-025	*QU10-025	N/A	N/A	3PU10-025	100WSU10-025	AU10-025
HN15S	*C10-025	*IU10-025	*DS10-025	*QU10-025	N/A	N/A	3PU10-025	100WSU10-025	AU10-025
HN2S	*C10-025	*IU10-025	*DS10-025	*QU10-025	N/A	N/A	3PU10-025	100WSU10-025	AU10-025
HN1L	*C10-050	*IU10-050	*DS10-050	*QU10-050	N/A	N/A	3PU10-050	100WSU10-025	AU10-050
HN15L	*C10-050	*IU10-050	*DS10-050	*QU10-050	N/A	N/A	3PU10-050	100WSU10-025	AU10-050
HN2L	*C10-050	*IU10-050	*DS10-050	*QU10-050	N/A	N/A	3PU10-050	100WSU10-025	AU10-050
HN3S	*C15-060	*IU15-060	*DS15-060	*QU15-060	N/A	N/A	3PU15-060	100WSU15-060	AU15-060
HN4S	*C15-060	*IU15-060	*DS15-060	*QU15-060	N/A	N/A	3PU15-060	100WSU15-060	AU15-060
HN4L	*C15-095	*IU15-095	*DS15-095	*QU15-095	N/A	N/A	3PU15-095	100WSU15-060	AU15-095
HN5S	*CU25-130	*CU25-130	*DS25-130	*QU25-130	ME25-130	7CVP25-130	3PU25-130	100WS25-130	AU25-130
HN6S	*CU25-130	*CU25-130	*DS25-130	*QU25-130	ME25-130	7CVP25-130	3PU25-130	100WS25-130	AU25-130
HN8E	*CU25-130	*CU25-130	*DS25-130	*QU25-130	ME25-130	7CVP25-130	3PU25-130	100WS25-130	AU25-130
HN8S	*CU25-187	*CU25-187	*DS25-187	*QU25-187	ME25-187	7CVP25-187	3PU25-187	100WS25-187	AU25-187
HN8L	*CU25-235	*CU25-235	*DS25-235	*QU25-235	ME25-235	7CVP25-235	3PU25-235	100WS25-235	AU25-235
HN0L	*CU35-280	*CU35-280	*DS35-280	*QU35-280	ME35-280	7CVP35-280	3PU35-280	100WS35-280	AU35-280
HN12L	*CU35-280	*CU35-280	*DS35-280	*QU35-280	ME35-280	7CVP35-280	3PU35-280	100WS35-280	AU35-280

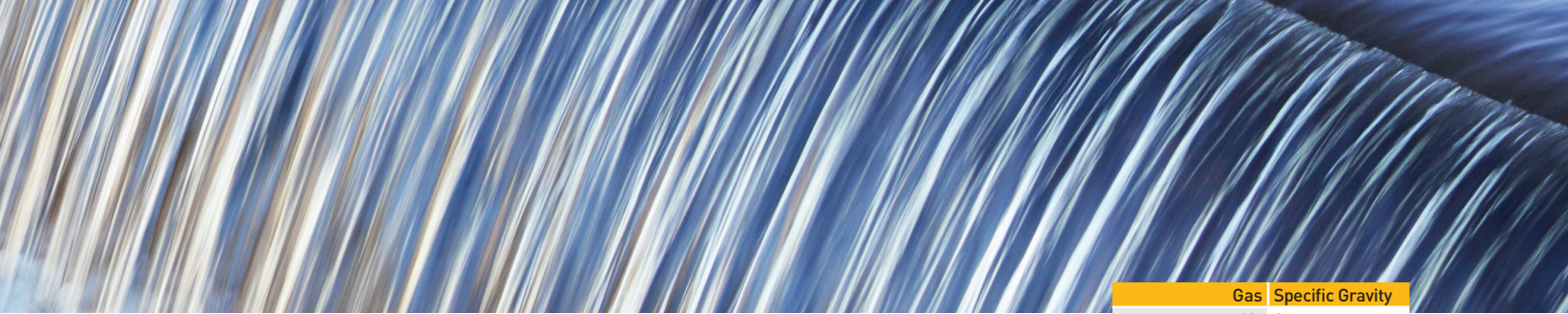

Gas	Specific Gravity
Air	1
Ammonia	0.58
Argon	1.37
Carbon Dioxide	1.52
Carbon Monoxide	0.96
Chlorine	2.48
Ethane	1.04
Ethylene	0.97
Helium	0.13
Hexane	2.73
Hydrogen	0.06
Methane	0.55
Natural Gas	0.66
Neon	0.69
Nitrogen	0.96
Oxygen	1.18
Pentane	2.47
Propane	1.56

Step 2a. Alternate Housing Selection Chart

Use this step for applications with technical gases or for applications that do not have standard conditions (100 PSIG and 70°F).

Because the required size of a filter is affected not only by flow, but also by operating pressure and operating temperature, it is necessary to convert those actual conditions to standardized conditions (100 PSIG and 70°F). The calculated adjusted flow rate can then be used to choose the appropriate filter in the chart on the previous page. When using the chart, choose the closest flow rate from the appropriate media grade column.

Note: Take the square root of your specific gravity. If this is for a compressed air application, skip this step because the specific gravity of air equals one. Please see chart to the right for specific gravities.

Flow Rate	Pressure	Temperature	Specific Gravity (See chart above)	Adjusted Flow Rate
Actual System Flow Rate (SCFM)	$\times \frac{(100 \text{ PSIG} + 14.7 \text{ PSIG})}{(\text{System Pressure (PSIG)} + 14.7 \text{ PSIG})}$	$\times \frac{(\text{System Temp. } ^\circ\text{F} + 460^\circ\text{F})}{70^\circ\text{F} + 460^\circ\text{F}}$	$\times \sqrt{\quad}$	$= \frac{\text{SCFM @ 100 PSIG, } 70^\circ\text{F}}$
Information Given: Flow Rate = 136 SCFM Pressure = 150 PSIG Actual Temperature = 100°F	$136 \text{ SCFM} \times \frac{(100 \text{ PSIG} + 14.7 \text{ PSIG})}{(150 \text{ PSIG} + 14.7 \text{ PSIG})}$	$\times \frac{(100^\circ\text{F} + 460^\circ\text{F})}{70^\circ\text{F} + 460^\circ\text{F}}$	$\times \sqrt{1}$	$= 100 \text{ SCFM}$

Now go to the chart on page 8, look down the media grade 6 column for a flow of 100 SCFM, you will see the correct housing is the HN4S.

Accessories

Consult Finite when choosing pre-installed accessories for gases other than air.



DPG Gauge



DPI Indicator



Auto Drain (AD-12)



Pre-installed Accessories

Accessory Designator	Installed with	Maximum Pressure	Maximum Temperature
A	Auto Drain	250 PSIG (17 bar)	175°F (79°C)
D	DPI Indicator	250 PSIG (17 bar)	175°F (79°C)
G	DPG Gauge	500 PSIG (34 bar)	175°F (79°C)
J	High Temp	250 PSIG (17 bar)	450°F (232°C)
N	No Accessories	500 PSIG (34 bar)	175°F (79°C)
P	DP Ports (1/8" NPT gauge ports)	500 PSIG (34 bar)	175°F (79°C)
V	Fluorocarbon O-rings	500 PSIG (34 bar)	175°F (79°C)
W	Auto Drain and DPI Indicator	250 PSIG (17 bar)	175°F (79°C)
X	Auto Drain and DP Ports	250 PSIG (17 bar)	175°F (79°C)
Y	Auto Drain and DGP Gauge	250 PSIG (17 bar)	175°F (79°C)

Other Compatible Accessories



TV-50 Timed Drain Valve	ZLD-013 Zero Loss Drain	VS-50 Visual Sump Drain (not shown: standard bowl guard)	MS-50 Metal Sump Drain (External)
210° F (99° C)	140° F (60° C)	125° F (52° C)	175° F (79° C)
300 PSIG (20 Bar)	232 PSIG (16 Bar)	150 PSIG (10 Bar)	250 PSIG (17 Bar)
1/2" NPT	1/2" NPT	1/2" NPT	1/2" NPT

- The accessories above are compatible with this product line, however, they are sold separately. Other timed drain valves can be found in Finite's Catalog 1300-300-06/USA.
- Auto drains require a minimum operating pressure of 10 PSIG to seal.
- Mounting brackets available: BK-M (1/4" - 1/2" connections); BK-3 (3/4" - 1" connections).

How to Order

Use the steps below to build your own part number.
For any permutation not mentioned below, please consult factory at 1-800-521-4357.

Step 2 or 2a

H	N	1 2	L -
Series Name	Port Type	Port Size (Connection)	Bowl ³
	N - NPT	1 - 1/4" 5 - 1/4"	S - Standard
	F - BSPP	15 - 3/8" 6 - 1/2"	L - Long
	S - SAE ¹	2 - 1/2" 8 - 2"	E - Economy
	T - BSPT	3 - 3/4" 0 - 2 1/2"	(short bowl) ²
		4 - 1" 12 - 3"	

1. SAE-32 2" connection only
2. Bowl length is determined by the flow rate required. See page 8, Housing Selection Chart, for flow rates.
3. Economy bowl is only available on 2" connection size.

4

Examples of How to Order

Example 1

HN12L-6CUY

What am I ordering?

An H-Series, with a 3" NPT connection, long bowl, standard grade 6 coalescing element with urethane end seals, an auto drain, and a standard DPG gauge.

Example 2

HN15L-8CA

What am I ordering?

An H-Series, with a 3/8" NPT connection, long bowl, grade 8 coalescing element without end seals and an auto drain.

Example 3

HN8S-7CVPG

What am I ordering?

An H-Series, with a 2" NPT connection, standard bowl, a 7CVP coalescing element, with the standard fluorocarbon end seals and standard DPG gauge.

Example 4

HN8E-10DVJ

What am I ordering?

An H-Series, with a 2" NPT connection, economy short bowl, grade 10 high-temp coalescing element, with the standard fluorocarbon end seals and "J" as an accessory. This high temperature option converts all materials to be capable of handling temperatures of 450°F.

Example 5

HN2S-AUN

What am I ordering?

An H-Series, with a 1/2" NPT connection, short bowl, adsorber element, with the standard urethane end seals and no accessories.

Step 1

6	C	U
Element Grade ¹	Element Type	End Seal
4	C	Blank No end seal, Standard on 1/4" to 1" connection sizes
6		U Urethane, Standard on 1/4" to 3" connection sizes
8		S Molded Silicone Rubber
10		V Fluorocarbon, Available 1/4" to 3" connections only
	Q	U Urethane, Standard on 1/4" to 3" connection sizes
		S Molded Silicone Rubber
		V Fluorocarbon, Available 1/4" to 3" connections only
	D	S Molded Silicone Rubber
		v Fluorocarbon, Available 1/4" to 3" connections only
7CVP 7DVP ME		Blank Fluorocarbon, Standard on all 7CVP, 7DVP, and ME elements; elements available 1/4" to 3" connections only
	I	U Urethane, Standard on 1/4" to 1" connection sizes
	3P	U Urethane, Standard on all connection sizes
		S Molded Silicone Rubber
		v Fluorocarbon, Available 1/4" to 3" connections only
100WS		U Urethane, Standard on 1/4" to 1" connection sizes
		Blank Fluorocarbon, standard on 100WS elements 1/4" to 3" connections only
	A	U Urethane, Standard on all connection sizes
		S Molded Silicone Rubber

1. Grades are available on element type C, Q, D, and I. For 7CVP, 7DVP, ME, 3P, 100WS, and A, leave this blank.

Drawings, Dimensions & Specifications

Step 3

G

Accessory Designator
for preinstalled accessories

- A - Auto Drain
- D - DPI Indicator
- G - DPG Gauge
(Standard on 3/4" & up)
- J - High Temperature (450°F)
- N - No Accessories
- P - 1/8" Differential (3/4" & up)
Sensing Ports
- V - Fluorocarbon O-rings
- W - A + D
- X - A + P
- Y - A + G

- For max. pressures and temperatures related to Accessories, please see chart on previous page.

Max. Pressure	500 PSIG (34 bar)
Safety Factor	Max. operating to burst 4:1
Max. Temp.	175°F (79°C) with option to 450°F (232°C)
Seals	Nitrile Std./Fluorocarbon optional
Materials	1/4" to 1" Port Size Housings: Aluminum - 380 Die cast heads; 6061 Drawn bowls 1 1/4" to 3" Port Size Housings: Aluminum - 356 Die cast heads; 6061 Drawn bowls
Coatings	Chromated heads and bowls; Powder painted exterior
Design	In-line threaded bowl to head

- Manual Drain port is 1/8" FNPT when tee valve is removed from drain bushing.

1/4" to 1" Port Size Housings

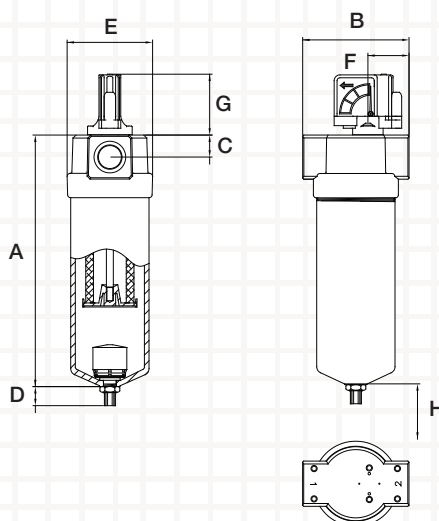

1 1/4" to 3" Port Size Housings

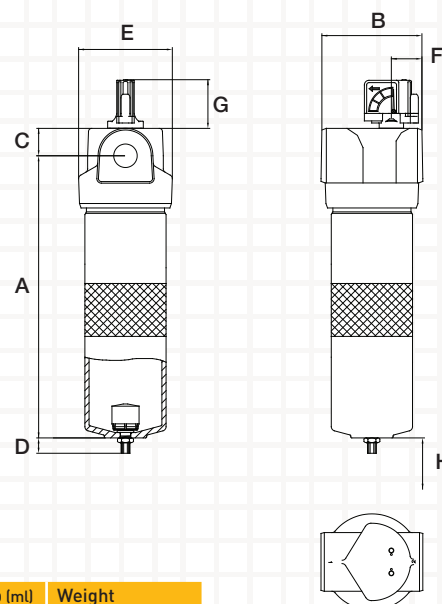

Model	A	B	C	D	E	F	G	H*	Sump (ml)	Weight
H_1S	6.80 (172)	3.12 (79)	.63 (16)	.79 (20)	2.98 (76)	1.56 (39.5)	2.6 (66)	2.99 (76)	150	1.49 (.68)
H_15S	6.80 (172)	3.12 (79)	.63 (16)	.79 (20)	2.98 (76)	1.56 (39.5)	2.6 (66)	2.99 (76)	150	1.47 (.66)
H_2S	6.80 (172)	3.12 (79)	.63 (16)	.79 (20)	2.98 (76)	1.56 (39.5)	2.6 (66)	2.99 (76)	150	1.44 (.65)
H_1L	9.19 (233)	3.12 (79)	.63 (16)	.79 (20)	2.98 (76)	1.56 (39.5)	2.6 (66)	5.51 (140)	140	1.89 (.86)
H_15L	9.19 (233)	3.12 (79)	.63 (16)	.79 (20)	2.98 (76)	1.56 (39.5)	2.6 (66)	5.51 (140)	140	1.87 (.85)
H_2L	9.19 (233)	3.12 (79)	.63 (16)	.79 (20)	2.98 (76)	1.56 (39.5)	2.6 (66)	5.51 (140)	140	1.85 (.84)
H_3S	10.86 (276)	4.65 (118)	.96 (24)	.79 (20)	3.68 (93.5)	1.73 (44)	2.6 (66)	6.5 (165)	270	3.56 (1.61)
H_4S	10.86 (276)	4.65 (118)	.96 (24)	.79 (20)	3.68 (93.5)	1.73 (44)	2.6 (66)	6.5 (165)	270	3.29 (1.49)
H_4L	14.36 (365)	4.65 (118)	.96 (24)	.79 (20)	3.68 (93.5)	1.73 (44)	2.6 (66)	10.0 (254)	270	4.11 (1.86)

Model	A	B	C	D	E	F	G	H*	Sump (ml)	Weight
H_5S	18.23 (463)	6.0 (152)	1.65 (42)	.83 (21)	5.67 (144)	1.85 (47)	2.6 (66)	13.50 (343)	440	12.11 (5.49)
H_6S	18.23 (463)	6.0 (152)	1.65 (42)	.83 (21)	5.67 (144)	1.85 (47)	2.6 (66)	13.50 (343)	440	11.97 (5.43)
H_8E	18.23 (463)	6.0 (152)	1.65 (42)	.83 (21)	5.67 (144)	1.85 (47)	2.6 (66)	13.50 (343)	440	11.97 (5.43)
H_8S	24.23 (617)	6.0 (152)	1.65 (42)	.83 (21)	5.67 (144)	1.85 (47)	2.6 (66)	19.25 (489)	530	14.00 (6.35)
H_8L	29.23 (742)	6.0 (152)	1.65 (42)	.83 (21)	5.67 (144)	1.85 (47)	2.6 (66)	24.02 (610)	620	15.99 (7.25)
H_0L	35.70 (907)	8.0 (203)	2.4 (61)	.83 (21)	7.24 (184)	2.36 (60)	2.6 (66)	28.50 (724)	880	35.00 (15.87)
H_12L	35.70 (907)	8.0 (203)	2.4 (61)	.83 (21)	7.24 (184)	2.36 (60)	2.6 (66)	28.50 (724)	880	34.14 (15.48)

1. Dimensions are in inches (millimeters); weight is in pounds (kilograms).
2. Clearance required to remove bowl.

 State of California ONLY
WARNING: Proposition 65
 The products described herein can expose you to chemicals known to the State of California to cause cancer or reproductive harm.
 For more information: www.P65Warnings.ca.gov

Worldwide Filtration Manufacturing Locations

North America

Compressed Air Treatment

Industrial Gas Filtration and Generation Division

Lancaster, NY
716 686 6400
www.parker.com/igfg

Haverhill, MA
978 858 0505
www.parker.com/igfg

Engine Filtration

Racor

Modesto, CA
209 521 7860
www.parker.com/racor

Holly Springs, MS
662 252 2656
www.parker.com/racor

Hydraulic Filtration

Hydraulic & Fuel Filtration

Metamora, OH
419 644 4311
www.parker.com/hydraulicfilter

Laval, QC Canada
450 629 9594
www.parkerfarr.com

Velcon
Colorado Springs, CO
719 531 5855
www.velcon.com

Process Filtration

domnick hunter Process Filtration SciLog

Oxnard, CA
805 604 3400
www.parker.com/processfiltration

Water Purification

Village Marine, Sea Recovery, Horizon Reverse Osmosis

Carson, CA
310 637 3400
www.parker.com/watermakers

Europe

Compressed Air Treatment

domnick hunter Filtration & Separation

Gateshead, England
+44 (0) 191 402 9000
www.parker.com/dhfn

Parker Gas Separations

Etten-Leur, Netherlands
+31 76 508 5300
www.parker.com/dhfn

Hiross Airtek

Essen, Germany
+49 2054 9340
www.parker.com/hzfd

Padova, Italy
+39 049 9712 111
www.parker.com/hzfd

Engine Filtration & Water Purification

Racor

Dewsbury, England
+44 (0) 1924 487 000
www.parker.com/rfde

Racor Research & Development

Stuttgart, Germany
+49 (0)711 7071 290-10

Hydraulic Filtration

Hydraulic Filter

Arnhem, Holland
+31 26 3760376
www.parker.com/hfde

Urjala, Finland
+358 20 753 2500

Condition Monitoring

Parker Kittiwake

West Sussex, England
+44 (0) 1903 731 470
www.kittiwake.com

Process Filtration

domnick hunter Process Filtration Parker Twin Filter BV

Birtley, England
+44 (0) 191 410 5121
www.parker.com/processfiltration

Asia Pacific

Australia

Castle Hill, Australia
+61 2 9634 7777
www.parker.com/australia

China

Shanghai, China
+86 21 5031 2525
www.parker.com/china

India

Chennai, India
+91 22 4391 0700
www.parker.com/india

Parker Fowler

Bangalore, India
+91 80 2783 6794
www.johnfowlerindia.com

Japan

Tokyo, Japan
+81 45 870 1522
www.parker.com/japan

Korea

Hwaseon-City
+82 31 359 0852
www.parker.com/korea

Singapore

Jurong Town, Singapore
+65 6887 6300
www.parker.com/singapore

Thailand

Bangkok, Thailand
+66 2186 7000
www.parker.com/thailand

Latin America

Parker Comercio Ltda. Filtration Division

Sao Paulo, Brazil
+55 12 4009 3500
www.parker.com/br

Pan American Division

Miami, FL
305 470 8800
www.parker.com/panam

Africa

Aeroport Kempton Park, South Africa
+27 11 9610700
www.parker.com/africa



Parker Hannifin Corporation
Industrial Gas Filtration and Generation Division
4087 Walden Avenue
Lancaster, NY 14086
phone 800 343 4048
www.parker.com/igfg



State of California ONLY
WARNING: Proposition 65
The products described herein can expose you to chemicals known to the State of California to cause cancer or reproductive harm.
For more information: www.P65Warnings.ca.gov