

AIR KNIFE MOUNTING



For Conveyor Top Drying

Each air knife comes with:

1. Mounting plate kit, part # 8001789-KIT-L or -R (installed on knife)
2. Mounting rod kit, part # 8006634

Instructions below are for mounting one air knife. For multiple air knives, repeat instructions and position air knives 1-4 feet apart, and preferably not less than 12" apart.

INSTRUCTIONS

1. Mount rods to conveyor: Drill two 11/32" holes, 2" on center vertically, on both sides of the conveyor to mount rod brackets. Alternatively, the brackets can be stud welded to the conveyor using 5/16" bolts. The bracket can be installed such that the knob is on either side and at any convenient height.
2. Install rods on the brackets such that the short upright is on the downstream side.
3. Using the knobs, adjust the height of the rods such that the horizontal portion of the rod is at or above the height of any conveyor rails.

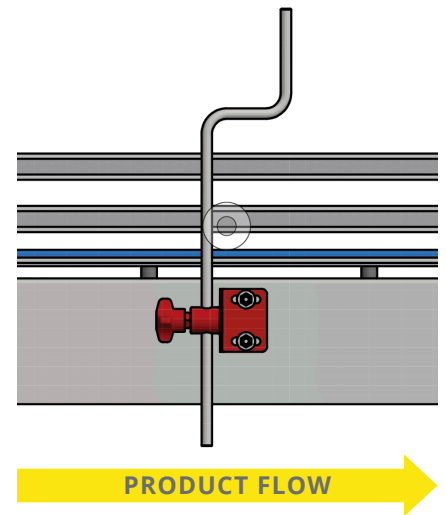

4. Install air knives by sliding the rods through the knobs on the air knife brackets. The air inlet should be positioned to minimize the distance / amount of hose from the blower. Remove tape that was holding the brackets in place during shipment.

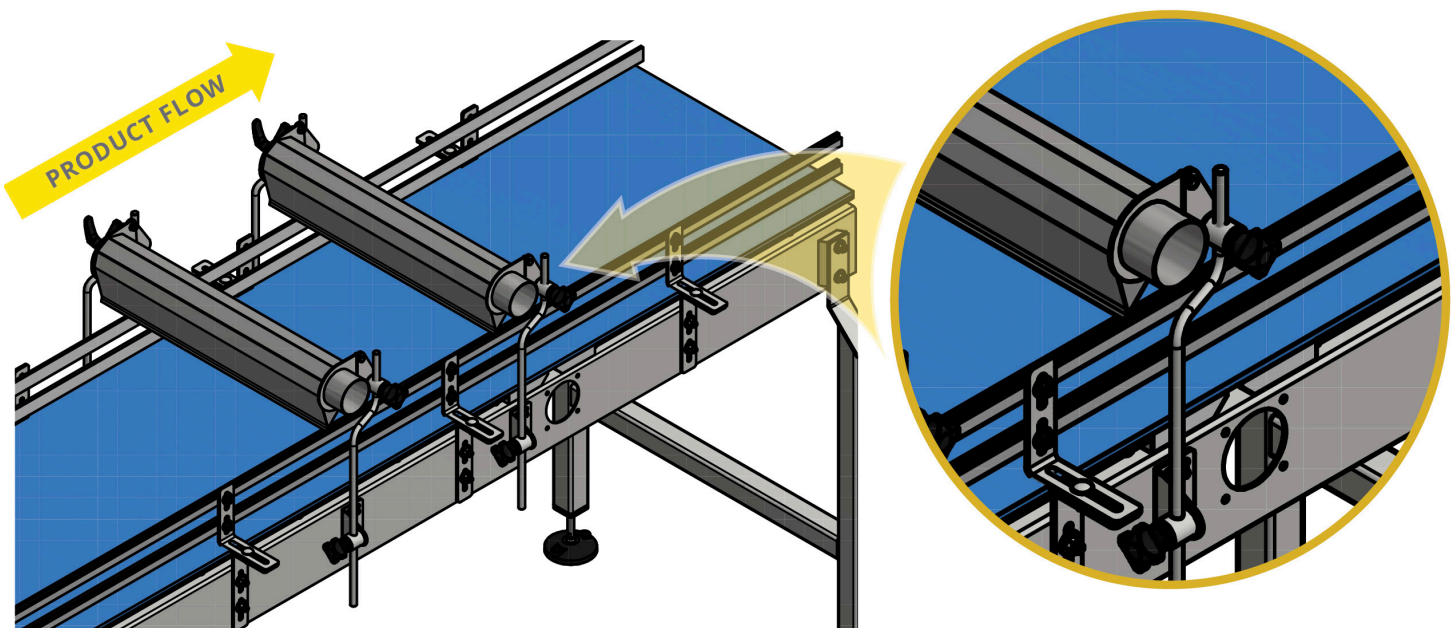

5

Adjust the height of the air knives, by sliding the rods up or down, such that the knife is positioned 1–2" above the top of the product being dried. It may be necessary to cut the rails to position the knives close to product.

6

The pitch of the air knives must be adjusted using the knob on the end of the air knife. The air knife should be tilted about 10° from vertical, against the flow.

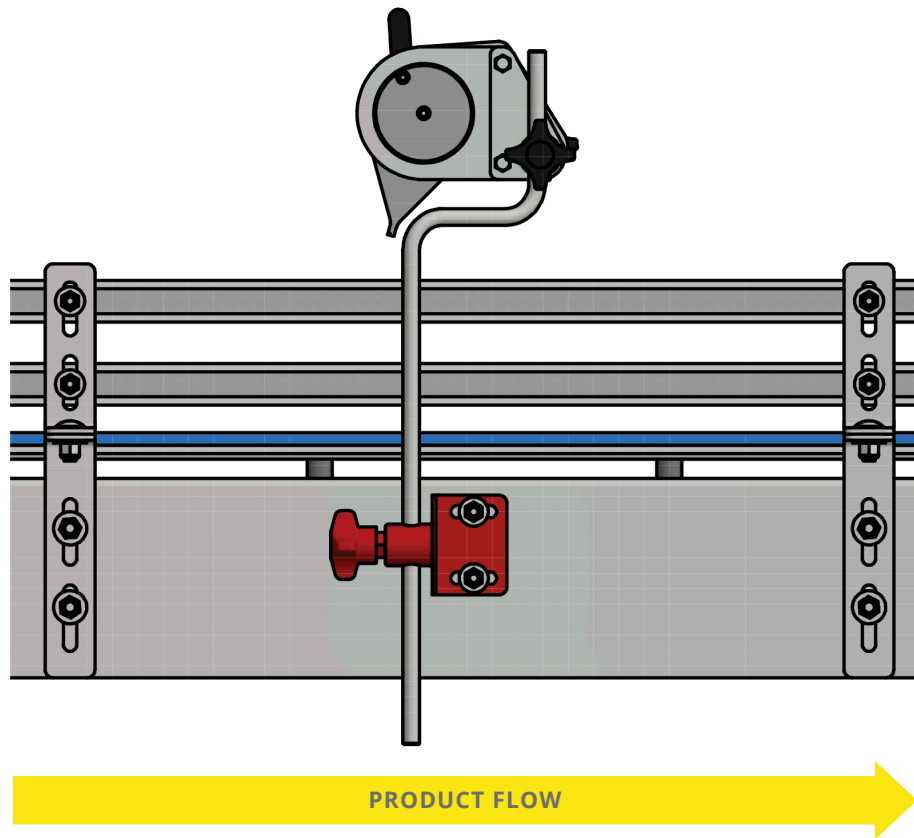

7

Install hose from blower to air knife inlet(s), using hose clamps.