

SANDPIPER EVOLUTION X 1" NON-METALLIC PUMP TECHNICAL DATA SHEET

EVOLUTION X™

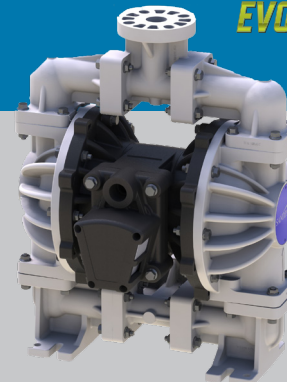

MODEL SPE10

STANDARD DUTY NON-METALLIC BALL VALVE PUMP

Patent Pending, High Performance AODD

PERFORMANCE

SUCTION / DISCHARGE PORT SIZE

- 1" ANSI/DIN Flange

CAPACITY

- 0 to 63 GPM (0 to 238 LPM)

AIR DISTRIBUTION VALVE

- No-lube, no-stall design

SOLIDS-HANDLING

- Up to .25 in. (6mm)

SUCTION LIFT

- 19' (5.8 m) Dry, 31' (9.5 m) Wet

HEADS UP TO

- 125 psi or 288 ft. of water
(8.6 bar or 88 meters)

MAXIMUM OPERATING PRESSURE

- 125 psi (8.6 bar)

DISPLACEMENT/STROKE

- .22 Gallon / .83 liter

WEIGHTS

- Polypropylene 25 lbs. (11.3kg)
- PVDF 42 lbs. (19kg)

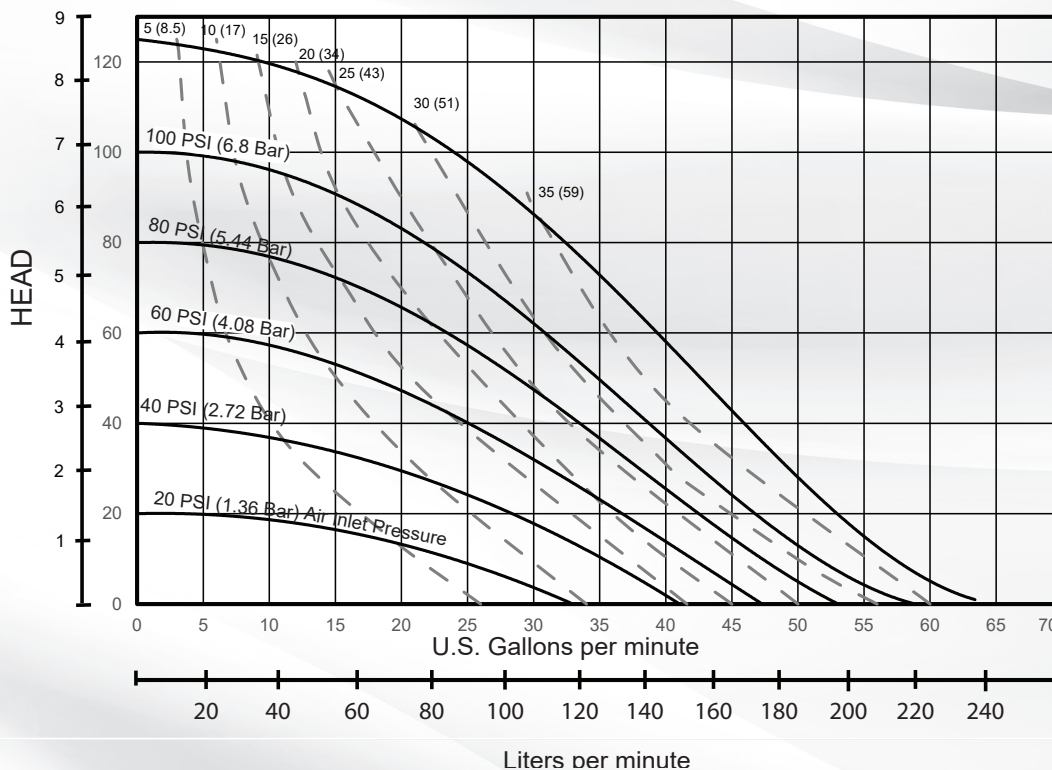

5 YEAR LIMITED PRODUCT WARRANTY

5 Year Guarantee for defects in material or workmanship. See sandpiperpump.com/content/warranty-certifications for complete warranty, including terms and conditions, limitations and exclusions.



USE ONLY GENUINE SANDPIPER PARTS

All certification, standards, guarantees & warranties originally supplied with this pump will be invalidated by the use of service parts not identified as "Genuine SANDPIPER Parts."

DIMENSIONS

SPE10 Non-Metallic Center Ported Options

Dimensions in inches (metric dimensions in brackets). Dimensional Tolerance .125" (3mm).

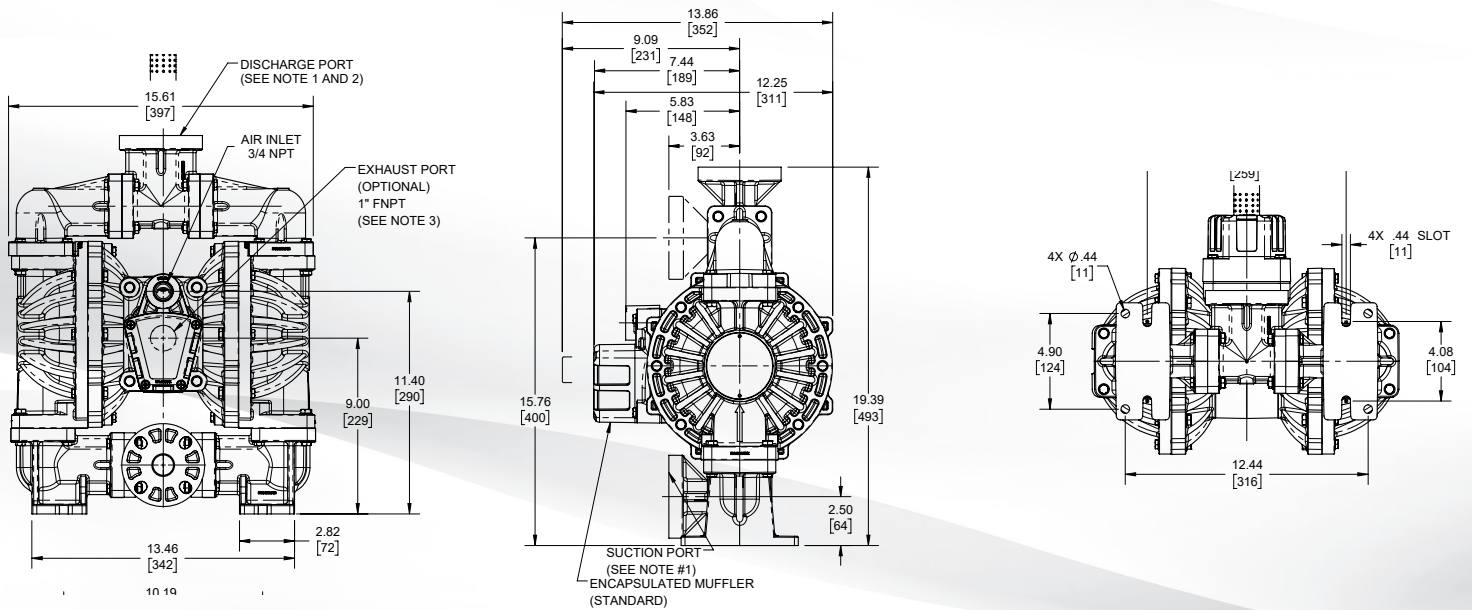

SPE10 Non-Metallic End Ported Option- Polypropylene Wet End Models ONLY

Dimensions in inches (metric dimensions in brackets). Dimensional Tolerance .125" (3mm).

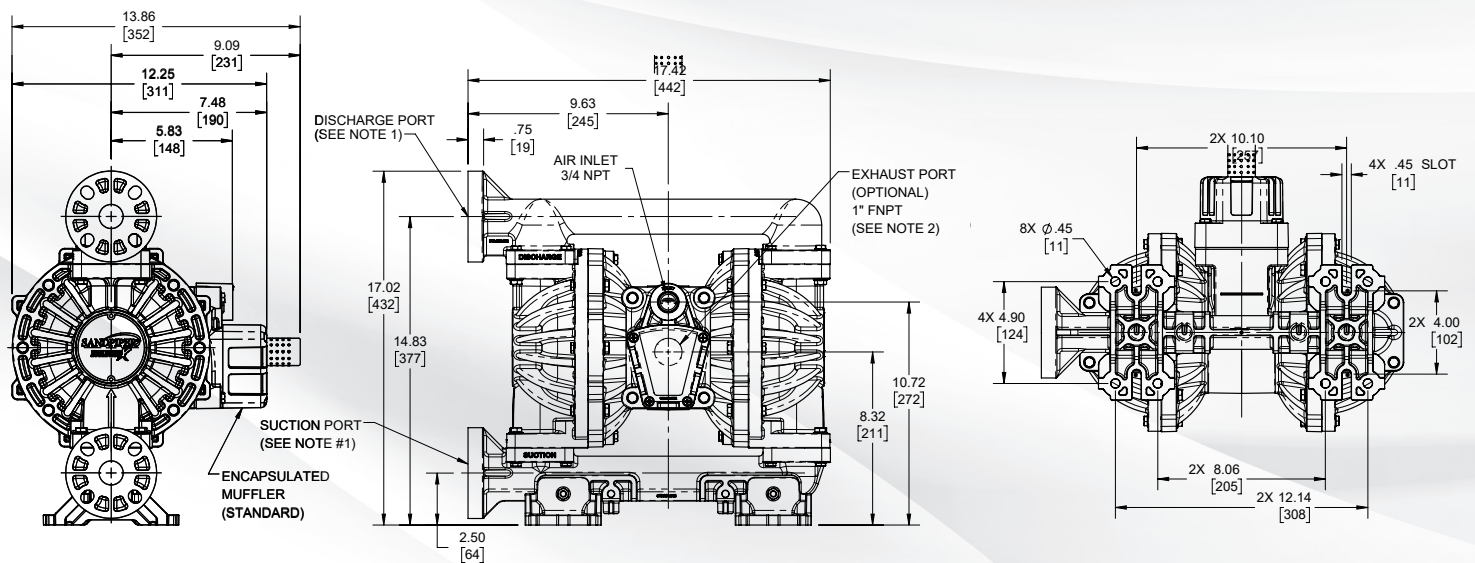

EXPLANATION OF PUMP NOMENCLATURE

Your Model #: SP E 10 B

(fill in from pump nameplate)

Position.....	Pump Brand	Product Line	Pump Size	Check Valve Type	Wetted Material	Non-Wetted Material	Diaphragm Material	Backup Diaphragm	Check Valve Material	Seat Material	Air Valve	Air Valve Option	Exhaust Option	Port Type	Port Option	Design Level
	P1	P2	P3	P4	P5	P6	P7	P8	P9	P10	P11	P12	P13	P14	P15	P16

PUMP BRAND

SP SANDPIPER

PRODUCT LINE

E Evolution

PUMP SIZE

10 1"

CHECK VALVE TYPE

B Ball

WET END MATERIALS

C Conductive Polypropylene

K PVDF (Kynar)

P Polypropylene

NON-WETTED MATERIAL

C Conductive Polypropylene

P Polypropylene

DIAPHRAGM MATERIAL

B Nitrile (Buna)

E EPDM

H Hytrel (FDA Compliant)

N Neoprene

R Santoprene

T PTFE Overlay

V FKM (Viton)

Z One Piece Bonded PTFE

*BACKUP DIAPHRAGM

B Nitrile (Buna)

N Neoprene

R Santoprene

O None

CHECK VALVE MATERIAL

B Nitrile

N Neoprene

R Santoprene

T PTFE

SEAT MATERIAL

K PVDF (Kynar)

P Polypropylene

AIR VALVE

0 SANDPIPER Standard

AIR VALVE OPTION

0 Matched ground sleeve and spool

EXHAUST OPTION

0 Encapsulated Polypropylene

1 Encapsulated Conductive Polypropylene

6 Threaded Metal

PORT TYPE

U Universal ANSI/DIN Flange

PORT OPTION

C Center Ported

D Dual Suction / Dual Discharge

E End Ported

F Suction Only Dual Ported

G Discharge Only Dual Ported

DESIGN LEVEL

1 Design Level

*If T is selected for Diaphragm Material, select backup diaphragm "N or R"

*If Z is selected for Diaphragm Material, the backup will be "B"

*For all other Diaphragm Materials, the backup will be "0"

MATERIALS

Material Profile:	Operating Temperatures:	
	Max.	Min.
CAUTION! Operating temperature limitations are as follows:		
CONDUCTIVE ACETAL: Tough, impact resistant, ductile. Good abrasion resistance and low friction surface. Generally inert, with good chemical resistance except for strong acids and oxidizing agents.	190°F 88°C	-20°F -29°C
EPDM: Shows very good water and chemical resistance. Has poor resistance to oils and solvents, but is fair in ketones and alcohols.	280°F 138°C	-40°F -40°C
FKM (FLUOROCARBON): Shows good resistance to a wide range of oils and solvents; especially all aliphatic, aromatic and halogenated hydrocarbons, acids, animal and vegetable oils. Hot water or hot aqueous solutions (over 70°F(21°C)) will attack FKM.	350°F 177°C	-40°F -40°C
HYTREL®: Good on acids, bases, amines and glycols at room temperatures only.	220°F 104°C	-20°F -29°C
NEOPRENE: All purpose. Resistance to vegetable oils. Generally not affected by moderate chemicals, fats, greases and many oils and solvents. Generally attacked by strong oxidizing acids, ketones, esters and nitro hydrocarbons and chlorinated aromatic hydrocarbons.	200°F 93°C	-10°F -23°C
NITRILE: General purpose, oil-resistant. Shows good solvent, oil, water and hydraulic fluid resistance. Should not be used with highly polar solvents like acetone and MEK, ozone, chlorinated hydrocarbons and nitro hydrocarbons.	190°F 88°C	-10°F -23°C
NYLON: 6/6 High strength and toughness over a wide temperature range. Moderate to good resistance to fuels, oils and chemicals.	180°F 82°C	32°F 0°C

POLYPROPYLENE: A thermoplastic polymer. Moderate tensile and flex strength. Resists strong acids and alkali. Attacked by chlorine, fuming nitric acid and other strong oxidizing agents.	180°F 82°C	32°F 0°C
PVDF: (Polyvinylidene Fluoride) A durable fluoroplastic with excellent chemical resistance. Excellent for UV applications. High tensile strength and impact resistance.	250°F 121°C	0°F -18°C
SANTOPRENE®: Injection molded thermoplastic elastomer with no fabric layer. Long mechanical flex life. Excellent abrasion resistance.	275°F 135°C	-40°F -40°C
UHMW PE: A thermoplastic that is highly resistant to a broad range of chemicals. Exhibits outstanding abrasion and impact resistance, along with environmental stress-cracking resistance.	180°F 82°C	-35°F -37°C
URETHANE: Shows good resistance to abrasives. Has poor resistance to most solvents and oils.	150°F 66°C	32°F 0°C
VIRGIN PTFE: (PFA/TFE) Chemically inert, virtually impervious. Very few chemicals are known to chemically react with PTFE; molten alkali metals, turbulent liquid or gaseous fluorine and a few fluoro-chemicals such as chlorine trifluoride or oxygen difluoride which readily liberate free fluorine at elevated temperatures.	220°F 104°C	-35°F -37°C
Maximum and Minimum Temperatures are the limits for which these materials can be operated. Temperatures coupled with pressure affect the longevity of diaphragm pump components. Maximum life should not be expected at the extreme limits of the temperature ranges.		
Metals:		
ALLOY C: Equal to ASTM494 CW-12M-1 specification for nickel and nickel alloy.		
STAINLESS STEEL: Equal to or exceeding ASTM specification A743 CF-8M for corrosion resistant iron chromium, iron chromium nickel and nickel based alloy castings for general applications. Commonly referred to as 316 Stainless Steel in the pump industry.		

For specific applications, always consult the Chemical Resistance Chart.



NOTE: See service manual for ATEX details.