



PATRICK CAIN DESIGNS

Made in Los Angeles

MANZA

DIAMETER: 16"
HEIGHT: Up to 19"

COLORS: Grey, Black, Chromatic Concrete,
Custom Ombre
MATERIAL: Concrete & Recycled Styrofoam

WEIGHT: Approximately 35 lbs
LEAD TIME: Typically, 2 - 3 Days
PRODUCTION CAPABILITY: 2 per Day
*Potentially more on large orders | Contact for questions

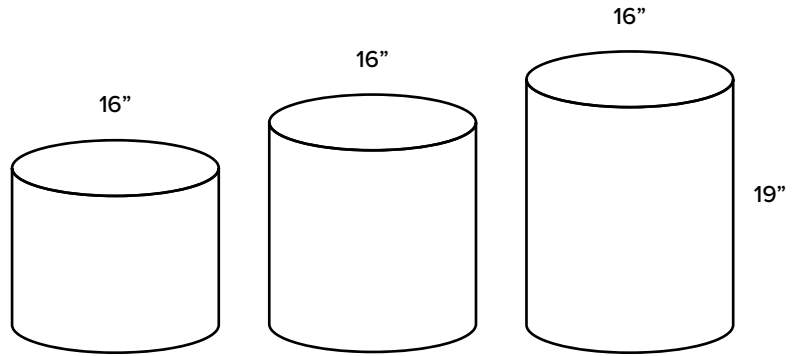



PATRICK CAIN DESIGNS

Made in Los Angeles

MANZA (QUICK SHIP)

DIAMETER: 16"
HEIGHT: Up to 19"

COLORS: Grey
MATERIAL: Concrete & Recycled Styrofoam

WEIGHT: Approximately 35 lbs
LEAD TIME: Quick Ship
MINIMUM HELD QUANTITY: 5

