

# Thoughtfully Designed Education Furniture

Complete Range Of Furniture Solutions  
From Kindergarten To University



EDUCATION  
FURNITURE



# INDEX





<b>About Us .....</b>	<b>02</b>
<b>Pri-Primary Furniture Solutions .....</b>	<b>04</b>
<b>Primary / Secondary Furniture Solutions .....</b>	<b>14</b>
<b>Faculty Furniture Solutions .....</b>	<b>22</b>
<b>Teaching Aid Solutions .....</b>	<b>24</b>
<b>Library Furniture Solutions .....</b>	<b>26</b>
<b>Hostel Furniture Solutions .....</b>	<b>28</b>
<b>Principal's Cabin Furniture Solutions .....</b>	<b>30</b>
<b>Admin Office Furniture Solutions .....</b>	<b>32</b>
<b>Training Furniture Solutions .....</b>	<b>34</b>
<b>Storage Solutions .....</b>	<b>36</b>
<b>Cafeteria Furniture Solutions .....</b>	<b>38</b>
<b>Waiting Area Furniture Solutions .....</b>	<b>42</b>
<b>Cambro Nilkamal Hospitality Solutions .....</b>	<b>42</b>

## THOUGHTFULLY DESIGNED



Ensure Efficient Learning with Nilkamal Education Furniture Solutions made by experts after detailed understanding of student's need for agility, movement and flexibility. Our furniture is designed to deliver:

- **Enhanced Ergonomics** - Suited to support age and height of students across age groups to support long hours of sitting
- **Child safety** - All our solutions have been crafted with rounded corners and pinch safe design
- **Flexibility** - Stackable and lightweight solutions to easily convert spaces into multi-utility spaces

## MANUFACTURING EXCELLENCE



Nilkamal Is Known For World Class Manufacturing. Our State-of The Art Manufacturing Facilities Are Accomplished With Latest International Technology To Deliver High Quality Furniture Solutions Across Materials Like

- Wood
- Metal
- Fabric
- Plastic.

# CERTIFIED QUALITY

Our Healthcare products are tested for quality from raw material to packaging in our in-house state of the art laboratories. All our offerings are certified for quality and safety standards by leading institutions.



**ISO9001:2015**



**ISO14001:2015**



**ISO 45001:2018**



**ISO50001:2018**

**BIFMA LEVEL 3**

**AIOTA**

**GreenGUARD**

## AWARDS



**FROST & SULLIVAN**

WITH ECONOMICS TIMES  
FOR EXCELLENCE IN MANUFACTURING



**G.O.I AWARD**

FOR ENERGY MANAGEMENT



**CII AWARD**

EXCELLENCE IN  
ENERGY MANAGEMENT

# PRE-PRIMARY FURNITURE SOLUTIONS



## Featured Products :

Petal Activity Desk, Grape Chair and Cube Storage



# PRE-PRIMARY FURNITURE SOLUTIONS



## CHR 5260 / 5300 / 5325

- Monoblock Structure
- Vibrant Colours
- Portable and Stackable
- Multiple Height Options

**Dimensions:** 352mm (W) X 360mm (D) X 503 / 543 / 568mm (H)

**Available Colours:** 

## GRAPE

- Comfortable seating
- Easy-to-clean & Maintain
- Sturdy Round Legs
- Portable and stackable

**Dimensions:** 440mm (W) X 530mm (D) X 620mm (H)

**Available Colours:** 



## CURRENT

- Comfortable seating
- Easy-to-clean & Maintain
- Durable and stylish
- Portable and stackable

**Dimensions:** 440mm (W) X 530mm (D) X 620mm (H)

**Available Colours:** 







### EEEZY GO BABY

- Comfortable seating
- Easy-to-clean & Maintain
- Durable and stylish
- Portable and stackable

**Dimensions:** 425mm (W) X 388mm (D) X 554mm (H)

**Available Colours:** ● ● ● ● ●

### CHR 5026

- Monoblock Structure
- Comfortable High Back
- Safe Round Edges
- Portable and Stackable

**Dimensions:** 440mm (W) X 530mm (D) X 620mm (H)

**Available Colours:** ● ● ●



### CHR 5027

- Monoblock Structure
- Safe Round Edges
- Easy-to-Clean & Maintain
- Portable and Stackable

**Dimensions:** 440mm (W) X 375mm (D) X 607mm (H)

**Available Colours:** ● ● ● ●

# PRE-PRIMARY FURNITURE SOLUTIONS



## ORANGE RECTANGLE ACTIVITY TABLE

- Sturdy Construction with MDF Table Top
- Height Adjustable Telescopic Legs
- Multiple Layout Configurations Possible
- Colorful Aesthetics

### Dimensions:

1100mm (W) X 550mm (D) X 370-620mm (H)

Available Colours:

## ORANGE SQUARE ACTIVITY TABLE

- Sturdy Construction with MDF Table Top
- Height Adjustable Telescopic Legs
- Space Optimisation
- Colorful Aesthetics

Dimensions: 550mm (W) X 550mm (D) X 370-620mm (H)

Available Colours:



## ORANGE TRAPEZOID ACTIVITY TABLE

- Sturdy Construction with MDF Table Top
- Height Adjustable Telescopic Legs
- Multiple Layout Configurations Possible
- Colorful Aesthetics

Dimensions: 1100mm (W) X 550mm (D) X 370-620mm (H)

Available Colours:



## ORANGE PETAL ACTIVITY TABLE

- Sturdy Construction with MDF Table Top
- Height Adjustable Telescopic Legs
- Multiple Layout Configurations Possible
- Colorful Aesthetics

**Dimensions:** 620mm (W) X 710mm (D) X 370-620mm (H)

**Available Colours:**

## ORANGE MOON ACTIVITY TABLE

- Sturdy Construction with MDF Table Top
- Height Adjustable Telescopic Legs
- Multiple Layout Configurations Possible
- Colorful Aesthetics

**Dimensions:** 675mm (W) X 675mm (D) X 370-620mm (H)

**Available Colours:**



## ORANGE CIRCLE ACTIVITY TABLE

- Sturdy Construction with MDF Table Top
- Perfect for Collaborative Study
- Height Adjustable Telescopic Legs
- Colorful Aesthetics

**Dimensions:** 900mm (Dia) X 370-620mm (H)

**Available Colours:**



# PRE-PRIMARY FURNITURE SOLUTIONS



## ORANGE BEAN ACTIVITY TABLE

- Sturdy Construction with MDF Table Top
- Height Adjustable Telescopic Legs
- Multiple Layout Configurations Possible
- Colorful Aesthetics

### Dimensions:

1083mm (W) X 614mm (D) X 370-620mm (H)

Available Colours: ●●●●

## ACTIVO

- Circle Shape High-Density Polyethylene Table Top
- Sturdy Construction
- Perfect for Colaborative Study
- Colorful Aesthetics

**Dimensions:** 1100mm (Dia) X 490mm (H)

**Available Colours:** ●●●



## SMILO

- Bean Shape High-Density Polyethylene Table Top
- Sturdy Construction
- Multiple Layout Configurations Possible
- Colorful Aesthetics

**Dimensions:** 1370mm (W) X 760mm (D) X 490mm (H)

**Available Colours:** ●●●



## SHISHU (ANGANWADI DESK)



- Space-Efficient Stackable Design
- Ideal for Two Kids
- Easy Cleaning and Maintenance

### Dimensions:

840mm (W) X 355mm (D) X 210mm (H)

Available Colours: 

## CUBE STORAGE

- Sturdy Construction
- Accessible Shelves for Kids
- Easy Cleaning and Maintenance
- Colorful Aesthetics

Dimensions: 1200mm (W) X 300mm (D) X 900mm (H)

Available Colours: 



## SLUMBER BED

- Sturdy Construction
- Portable and Stackable
- Easy To Clean and Maintain
- Comfortable

Dimensions: 1525mm (W) X 610mm (D) X 266mm (H)



# PRE-PRIMARY FURNITURE SOLUTIONS

You Can Create Multiple Classroom Layouts With The Nilkamal Activity Desk Range And Learning More Fun!

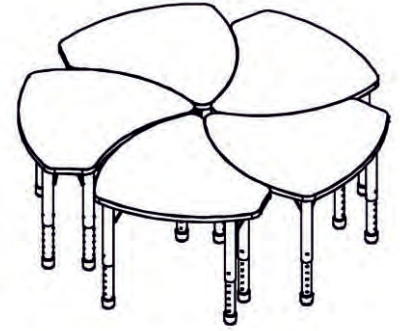
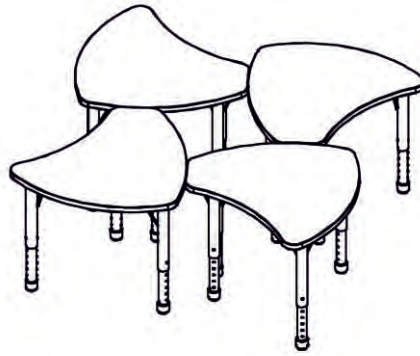
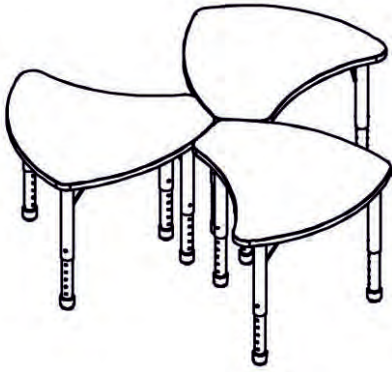

Layout Options: Orange Petal Activity Desk

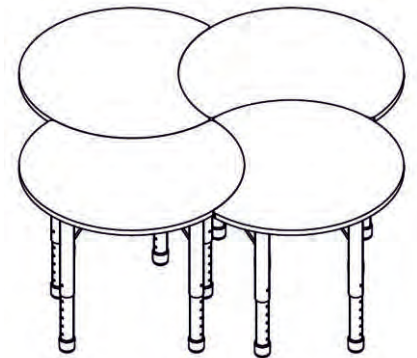
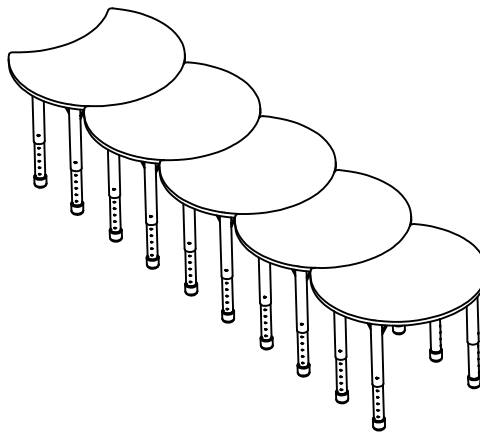
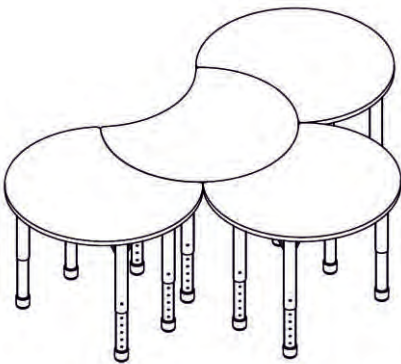

Layout Options: Orange Moon Activity Desk

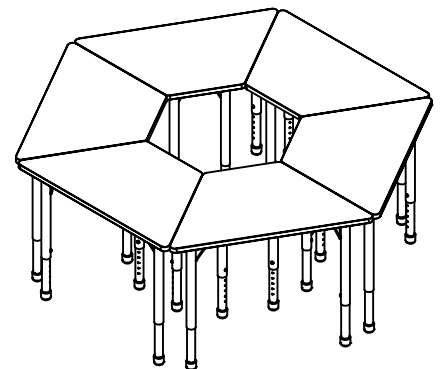
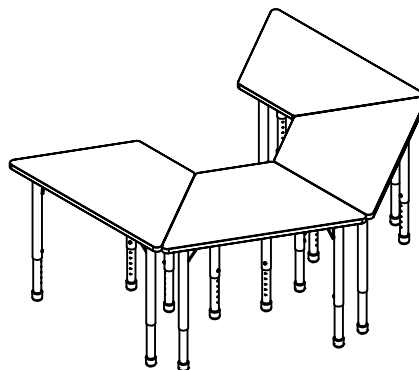
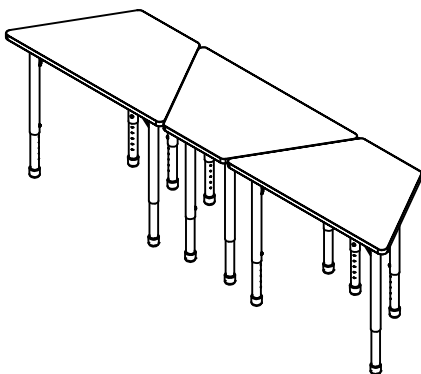

Layout Options: Orange Trapezoid Activity Desk

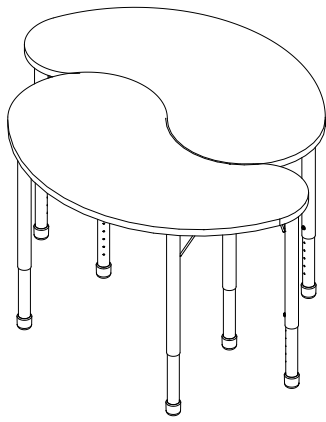

**Layout Options: Orange Bean Activity Desk**

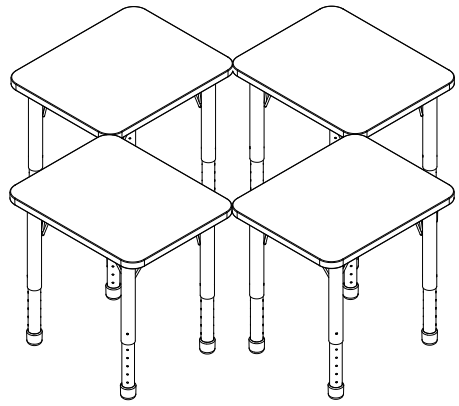

**Layout Options: Orange Square Activity Desk**

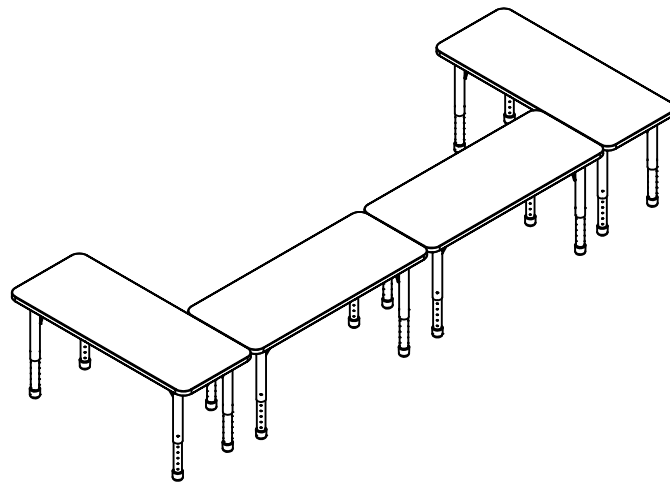

**Layout Options: Orange Rectangle Activity Desk**

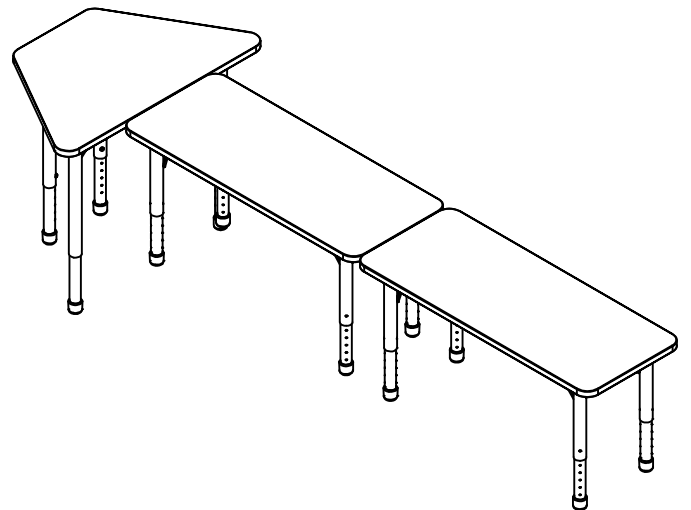
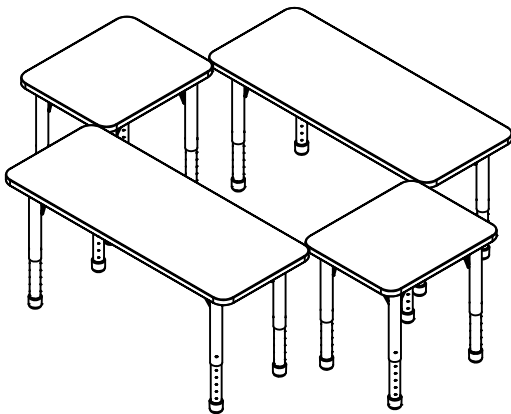

**Multi-Shape Layout Options**

# PRIMARY / SECONDARY FURNITURE SOLUTIONS



**Featured Products :**  
Sensible Desk, Stylo Teachers Desk,  
Thames Visitor Chair





# PRIMARY / SECONDARY FURNITURE SOLUTIONS



## AMPERE SINGLE DESK

- Stylish Learning Single Desk
- Convenient Mesh Drawer
- Sturdy Metal Structure
- Chip-Resistant MDF Top
- Multiple Height Options

### Dimensions:

610mm (W) X 470mm (D) X 650/700/750mm (H)

Available Colours: ● ●

## AMPERE DOUBLE DESK

- Stylish Learning Dual Desk
- Strong Mesh Drawer
- Sturdy Metal Structure
- Enough Leg Room for 2 Chairs
- Multiple Height Options

Dimensions: 1100mm (W) X 470mm (D) X 650/700/750mm (H)

Available Colours: ● ●



## OHMS SCHOOL CHAIR

- Modern Cantilever Design
- Durable Virgin Plastic
- Ergonomic Seat Shell
- Multiple Height Options

### Dimensions:

427mm (W) X 520mm (D) X 380/420/455mm (H)

Available Colours: ● ●



## AMPERE HEIGHT ADJUSTABLE TABLE

- Height Adjustable Single Desk
- Strong Mesh Drawer
- Sturdy Metal Structure
- Chip-Resistant MDF Top

**Dimensions:** 610mm (W) X 470mm (D) X 650-750mm (H)

**Available Colours:** ● ●

## HEIGHT ADJUSTABLE CHAIR

- Height Adjustable Chair
- Modern Cantilever Design
- Durable Virgin Plastic
- Ergonomic Seat Shell

**Dimensions:** 427mm (W) X 520mm (D) X 380-455mm (H)

**Available Colours:** ● ●



## SWING CHAIR

- Flexible Cantilever Design
- Lightweight and Stackable
- Ergonomic Seat Shell
- Multiple Height Options

**Dimensions:**

530mm (W) X 529mm (D) X 380/420/455mm (H)

**Available Colours:** ● ●

# PRIMARY / SECONDARY FURNITURE SOLUTIONS



## ORVILLE SINGLE DESK

- Stylish Learning Single Desk
- Built-In Storage
- Sturdy Metal Structure
- Premium Material
- Multiple Height Options

### Dimensions:

600mm (W) X 470mm (D) X 650/700/750mm (H)

Available Colours: ● ●

## ORVILLE DOUBLE DESK

- Stylish Learning Dual Desk
- Built-In Storage
- Sturdy Metal Structure
- Enough Leg Room for 2 Chairs
- Multiple Height Options

Dimensions: 1100mm (W) X 470mm (D) X 650/700/750mm (H)

Available Colours: ● ●



## HERTZ SCHOOL CHAIR

- Safe & Sturdy Structure
- Durable Virgin Plastic
- Ergonomic Seat Shell
- Multiple Height Options

Dimensions: 435mm (W) X 520mm (D) X 380/420/455mm (H)

Available Colours: ● ●



## SENSIBLE DESK CUM BENCH

- Space-Efficient Stackable Design
- Monolithic Structure for Ever Lasting Strength
- Colapsable Bookshelf
- Seamless Placement

### Dimensions:

1100mm (W) X 995mm (D) X 785mm (H)



Stackable

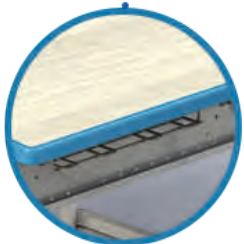

Bookshelf

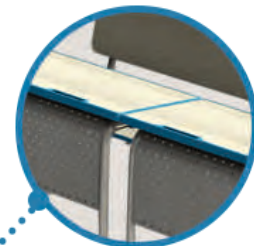

Seamless Placement

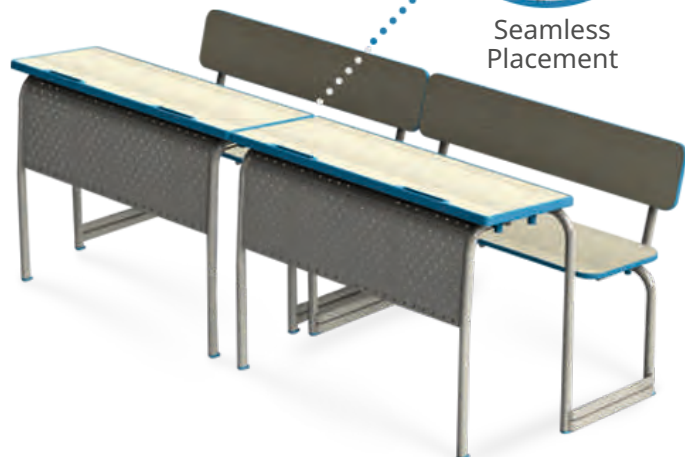

# PRIMARY / SECONDARY FURNITURE SOLUTIONS



## OXFORD - 2 SEATER DESK CUM BENCH

- Streamlined and Organized Look in a Room
- Sturdy Structure
- Balancing Utility and Elegance
- Easy to Maintain and Clean

### Dimensions:

1200mm (W) X 967mm (D) X 797mm (H)

## CLASSMATE DESK CUM BENCH

- Streamlined and Organized Look in a Room
- Sturdy Structure
- Easy to Maintain and Clean
- Multiple Size Options
- Available in Multiple Colours

### Dimensions:

1066mm (W) X 900mm (D) X 636mm (H)

1066mm (W) X 915mm (D) X 696mm (H)

1066mm (W) X 940mm (D) X 768mm (H)

1066mm (W) X 940mm (D) X 788mm (H)

Available Colours: 





### SMART DESK CUM BENCH

- Streamlined and Organized Look in a Room
- Sturdy Structure
- Easy to Maintain and Clean
- Bag Hook Provided On Both Side

**Dimensions:** 1048mm (W) X 868mm (D) X 668mm (H)

### FOCUS DESK CUM BENCH

- Streamlined and Organized Look in a Room
- Sturdy Structure
- Easy Access to Book Shelf
- Easy to Maintain and Clean

**Dimensions:** 1200mm (W) X 944mm (D) X 788mm (H)



# FACULTY FURNITURE SOLUTIONS



## Featured Products :

Stylo Teachers Desk, Thames Visitor Chair, Wonder White Board





## ARISTA

### Dimensions:

1200mm (W) X 600mm (D) X 730mm (H)  
1350mm (W) X 750mm (D) X 730mm (H)  
1500mm (W) X 750mm (D) X 730mm (H)  
1650mm (W) X 900mm (D) X 730mm (H)



## SYTLO TABLE

### Dimensions:

900mm (W) X 600mm (D) X 750mm (H)  
1200mm (W) X 600mm (D) X 750mm (H)  
1500mm (W) X 750mm (D) X 750mm (H)  
1800mm (W) X 900mm (D) X 750mm (H)



## NOAH TABLE

### Dimensions:

1200mm (W) X 600mm (D) X 750mm (H) | 1500mm (W) X 750mm (D) X 750mm (H)



## ALBA VISITOR



## NILE VISITOR



## THAMES VISITOR

# TEACHING AID SOLUTIONS

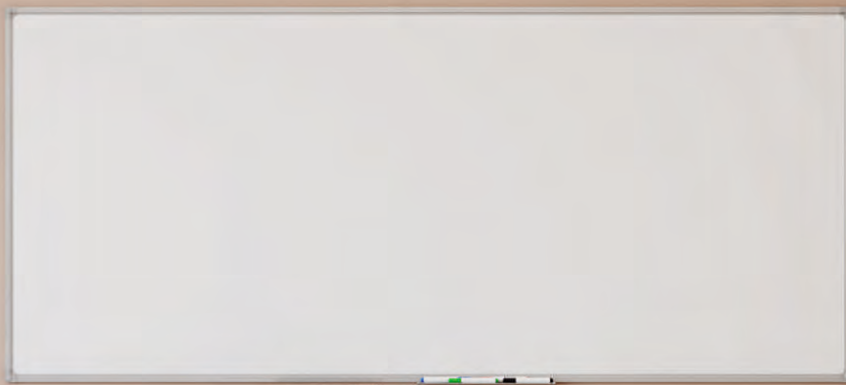

## **Featured Products :**

Wonder White Board, Stylo Teachers Desk, Focus Desk Cum Bench

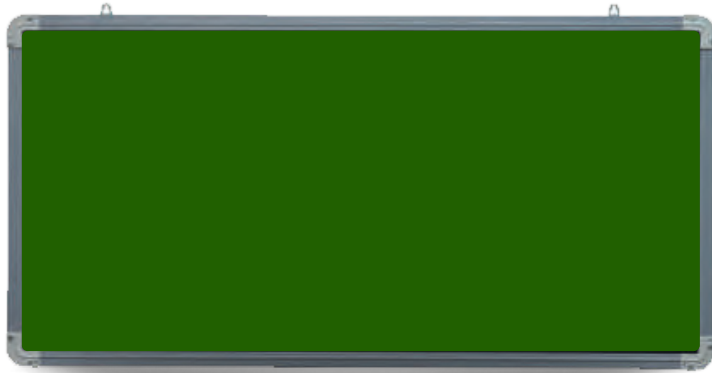

## WONDER GREEN BOARD

- Matt Black Finish for Smooth Writing Surface
- ABS Caps at Corner for enhanced Safety
- Easy Wall Mounting
- Light Weight

**Dimensions:**

1200mm (W) X 600mm (H) X 22.5mm (D)

## WONDER WHITE BOARD

- Semi Gloss White Finish for Smooth Writing Surface
- ABS Caps at Corner for enhanced Safety
- Easy Wall Mounting
- Light Weight

**Dimensions:**

1200mm (W) X 600mm (H) X 22.5mm (D)

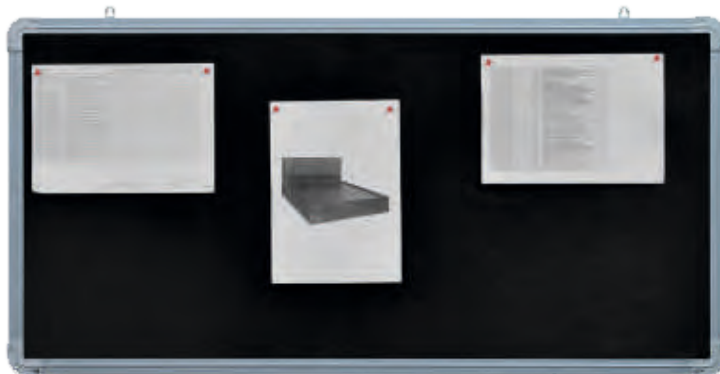

## WONDER SOFT BOARD

- Durable Construction to withstand repeated use
- ABS Caps at Corner for enhanced Safety
- Easy Wall Mounting
- Light Weight

**Dimensions:**

1200mm (W) X 600mm (H) X 22.5mm (D)

# LIBRARY FURNITURE SOLUTIONS



**Featured Products :**  
Open Racking System

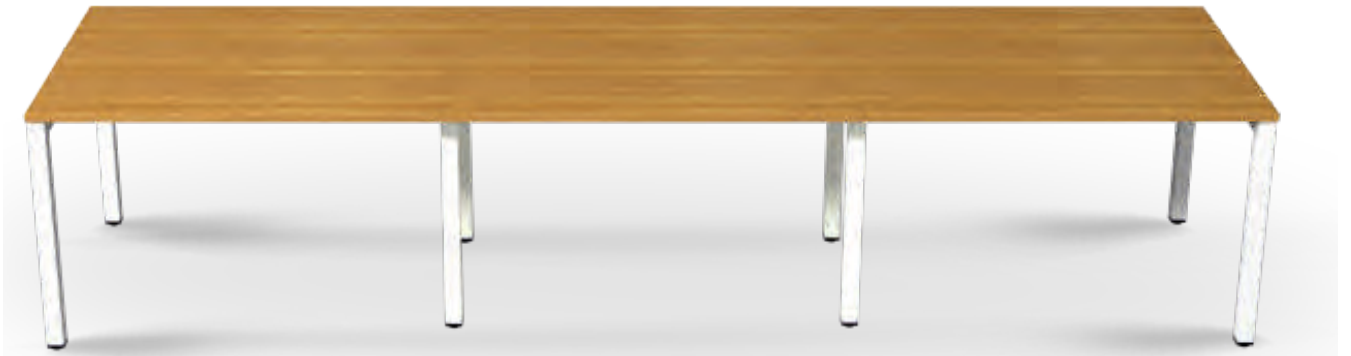

## OPTIMIZE LIBRARY TABLE

- Customisable Design
- Sturdy Under-Structure with 25 mm Table Top
- Easy to Maintain and Clean
- Enhances the Overall Aesthetics of Libraries



## OPEN RACKING SYSTEM

- Maximizes storage space for books and other items
- Ease of Assembly due to Knock Down Structure
- Accessible and Convenient
- Easy to Maintain and Clean

### Dimensions:

900mm (W) X 450mm (D) X 900/1200/1500/1800mm (H)



## CONTRACT 02 WITH ARM

### Dimensions:

550mm (W) X 605mm (D) X 788mm (H)



## FESTA WITH ARM

### Dimensions:

533mm (W) X 560mm (D) X 828mm (H)

# HOSTEL FURNITURE SOLUTIONS



**Featured Products :**  
Shine Bunk Bed, Cyrus Table, Amaze Chair



### RISE BUNK BED

**Dimensions:**

2045mm (W) X 995mm (D) X 1720mm (H)



### SHINE BUNK BED

**Dimensions:**

2045mm (W) X 995mm (D) X 1720mm (H)



### RAFEL METAL DOOR

**Dimensions:**

900mm (W) X 450mm (D) X 750/1200/2015mm (H)



### CYRUS TABLE

**Dimensions:**

1200mm (W) X 600mm (D) X 750mm (H)



### AMAZE CHAIR

**Dimensions:**

1200mm (W) X 600mm (D) X 750mm (H)

# PRINCIPAL'S CABIN FURNITURE SOLUTIONS



**Featured Products :**  
Volga chair and Optimize Cabin Table





I ELEGANT I



I DUALTONE I



I COMMAND HB I



I VOLGA PLUS HB I



I TRENTON HB I



I NILE NEO MB I



I ALBA VISITOR I



I INDUS CHAIR I

# ADMIN OFFICE FURNITURE SOLUTIONS



**Featured Products :**  
Victory Chair and Optimize Workstation Range



| GRACE WORKSTATION |



| TRANSFORM WORKSTATION |



| VOLGA MB |



| ALBA MB |



| VICTORY MB |



| HEXON MB |



| THAMES NEO MB |



| ZING WITH ARM |

# TRAINING AREA FURNITURE SOLUTIONS



**Featured Products :**  
Arena Step



I ARENA I



I GLORIUS I



I MAXIMUS+ I



I OPERA+ I



I AMAZE WITH FULL  
TABLET I



I CONTRACT 01 WITH  
FULL TABLET I



I ZING WITH  
WRITING PAD I

# STORAGE SOLUTIONS



**Featured Products :**  
Lockr Box PLU



I COMPACTOR I



I VAULT PLU I



I OPEN RACKING  
SYSTEM I



I VAULT SERIES I

# SOLUTIONS FOR CAFETERIA



**Featured Products :**  
Zayka Table and Crystal Chair





I ZAYKA SQUARE I



I ZAYKA ROUND I



I LAZIZ RECTANGLE I



I NOVELLA 07 I



I ZING I



I NOVELLA 19 I

# WAITING AREA FURNITURE SOLUTIONS



**Featured Products :**  
Italia 3 seater



I NOVELLA 07  
MULTI SEATER I



I STEELO  
2 & 3 SEATER I



I ITALIA  
2 & 3 SEATER I

I SIGNATURE  
VISITOR CHAIR I





**CAMBRO NILKAMAL  
HOSPITALITY SOLUTIONS**



I STORAGE SHELVING I



I HOLDING & TRANSPORT I



I STORAGE CONTAINER I





## Office Solutions

Our innovative office furniture solutions are designed to optimize productivity, collaboration, and comfort in the modern workplace. From ergonomic workstations and versatile storage solutions to collaborative meeting spaces and dynamic lounge areas, our office furniture seamlessly integrates functionality and style. We understand the evolving needs of today's businesses and offer customizable options to create a workspace that aligns with your company's culture and values.



## Auditorium Seating

Nilkamal furniture is a leading manufacturer of a complete range of auditorium seating furniture. The range finds wide application across institutions, including schools, colleges, universities, theatres, and conference halls. Our range is available in a variety of styles and finishes to complement any interior design. The range offers a variety of features to enhance the audience experience, such as cupholders and writing tablets.



## Healthcare Solutions

Nilkamal is a leading manufacturer of certified and tested hospital furniture in India. We offer a complete range of furniture for all hospital needs, and our team is committed to providing our customers with the highest quality products and services.



## Education Solutions

Nilkamal offers a complete range of certified and tested educational furniture for all institutions, from preschool to university. Our wide range of products includes student desks and chairs, teacher desks, classroom storage units, library furniture, and more. We offer customisable solutions for both government and private institutions.



- **13** MANUFACTURING FACILITIES
- **44** REGIONAL DEPOTS
- **60** REGIONAL OFFICES

### PRESENCE ACROSS 60+ CITIES IN INDIA:

Ahmedabad | Aurangabad | Indore | Jabalpur | Uran Dc | Nagpur | Raipur | Pune | Gwalior | Surat | Vasona | Akola | Bhaglpur | Bhubaneshwar | Guwahati | Patna | Ranchi | Sambalpur | Barjora | Kolkata | Siliguri | Delhi | Dharuhera | Haridwar | Jaipur | Punjab | Noida | Varanasi | Bareilly | Jammu | Kanpur | Bangalore | Kochi | Hubli | Hyderabad | Trichy | Vijaywada | Pondicherry | Coimbatore | Chennai | Hosur | Calicut | Ongole | Tuticorin



Head office: Nilkamal Ltd., Nilkamal House, Street No.14, MIDC, Andheri (E), Mumbai - 400 093  
 Tel: 022 4235 8503, Fax: 022-2835 3556 | Email: [educationsolutions@nilkamal.com](mailto:educationsolutions@nilkamal.com)  
[www.nilkamalfurniture.com](http://www.nilkamalfurniture.com) | Toll Free No: 1800 121 9115