

GARDENSTONE

Redefining Outdoor Planters

Gardenstone Inc
2851 Hwy 7, Concord ON, L4K 1W2
1 800-209-0917
sales@gardenstonemfg.com
www.gardenstonemfg.com

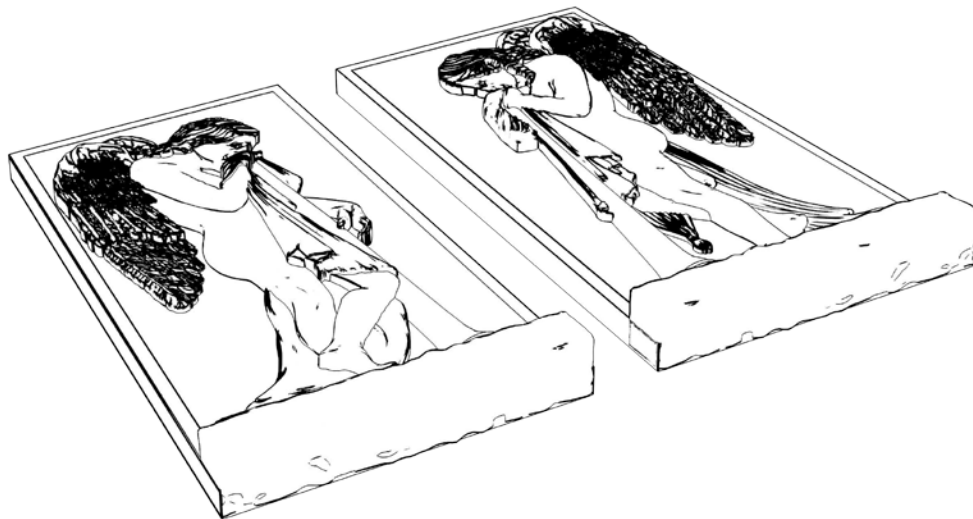
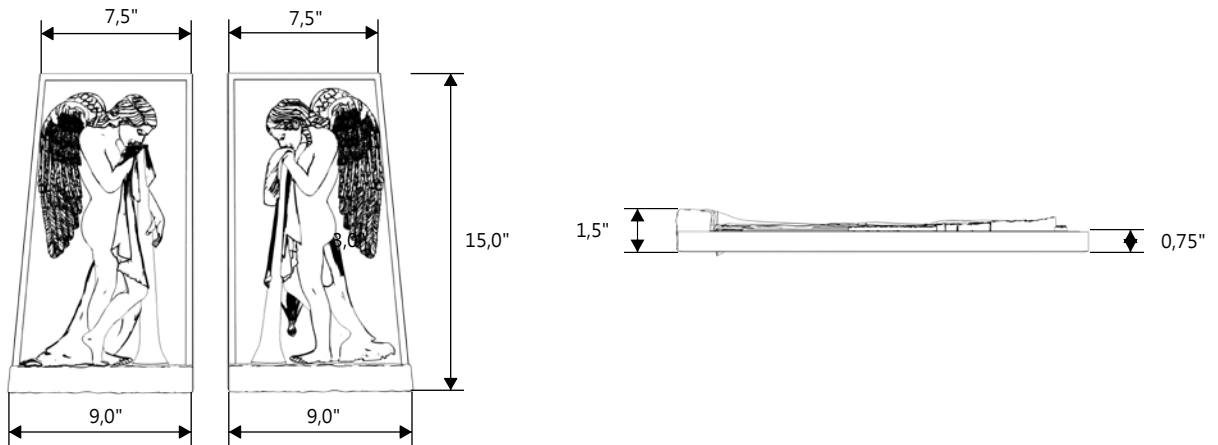

VATICAN ANGELS BRONZE (LEFT/RIGHT)

1590

WEIGHT: 10 LBS

NOTE: ALL INFORMATION ENCLOSED WAS CURRENT AT THE TIME OF DEVELOPMENT, BUT SHOULD BE REVIEWED BY THE PRODUCT MANUFACTURER TO BE CONSIDERED ACCURATE.