

# Remote Throwing System Assembly Instructions

[www.perfectmarc.com](http://www.perfectmarc.com)



## You've purchased the toughest and most reliable remote throwing system on the planet!

Thank you for trusting Perfect mARC to support you in achieving your retriever training objectives.

We're passionate about helping people, like you, who want to train retrievers with innovative products that reliably perform. That's why we set out to design a superior throwing system and we're confident we have successfully developed a solution that will help you build a better dog.

At Perfect mARC we value your safety, so please heed all warnings addressed in the user manual and be sure to follow maintenance guidelines. Failure to follow the safety guidelines can result in serious injury. It is essential that you read and comprehend all documentation prior to use.

Once again, thank you for your confidence in the Perfect mARC Remote Throwing System. We look forward to helping you and your dog TRAIN. TEST. TITLE.

Best Regards and Good Training,

Troy T. Miller - Owner  
Perfect mARC, LLC.



## Time and Space Required

- Assembles in about 30 - 45 minutes
- Access to at least an 8 ft x 8 ft space to set out components while assembling is helpful



## Tools Required

- 7/16" wrench
- 1/2" wrench
- Racketing socket wrench with 7/16" socket or 7/16" racketing wrench
- Medium size screw driver



## Scan the QR code for help.

These instructions are supplemented by videos. Simply use your mobile device to read the QR code at any step to see the corresponding YouTube video. You can also view the assembly video at [www.perfectmarc.com](http://www.perfectmarc.com)

# Finished Goods Box Contents

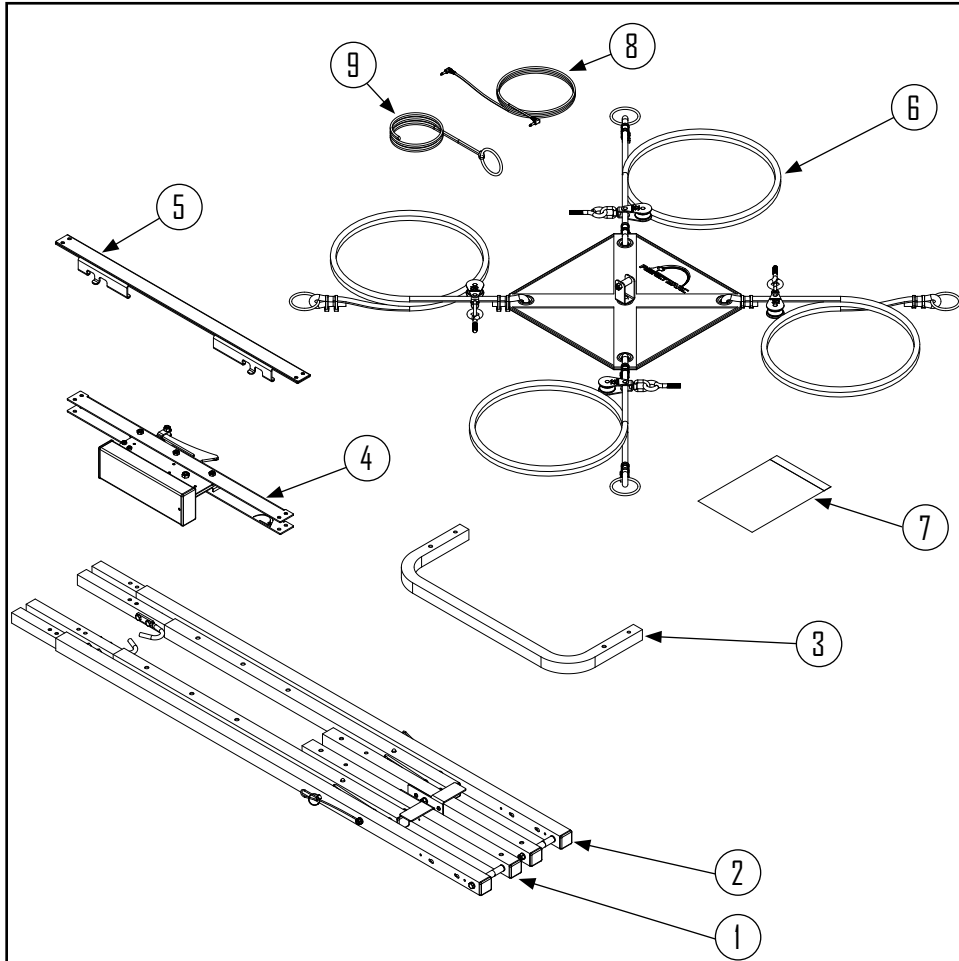

Item	Qty	Description
1	1	Right Leg Assembly
2	1	Left Leg Assembly
3	1	U-Brace
4	1	Trigger Assembly
5	1	Leg Brace
6	1	Pouch Assembly

# Hardware / Accessories

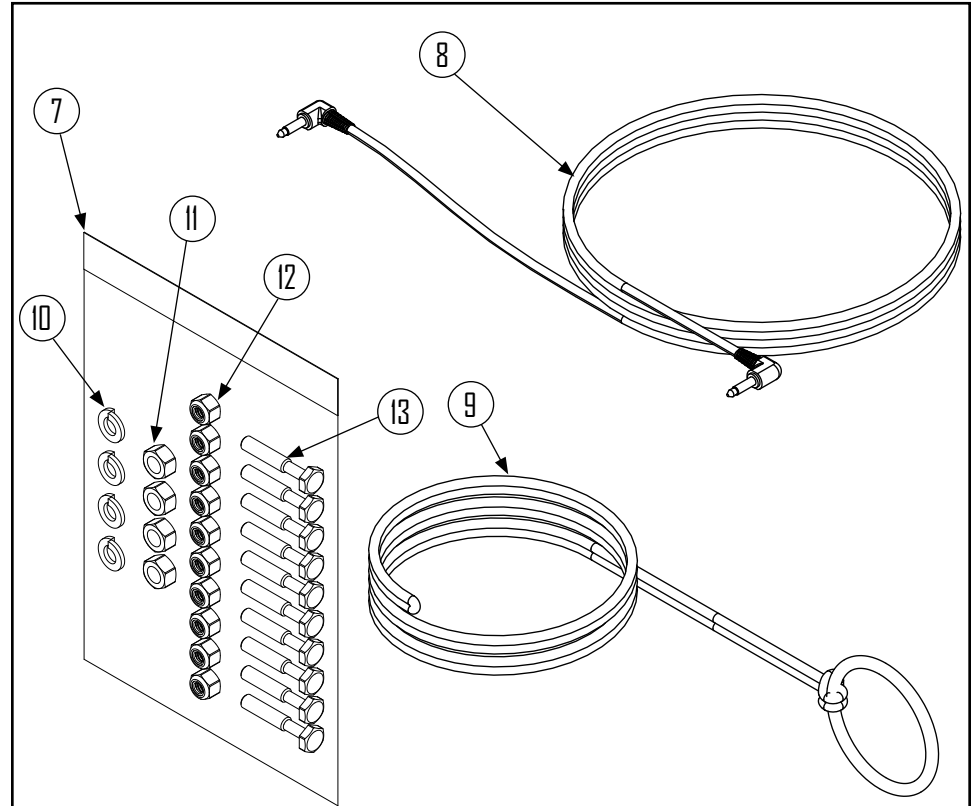

Item	Qty	Description
7	1	Hardware Pack
8	1	6' Electronics Cable
9	1	Manual Pull Lanyard
10	4	5/16" Lock Washer
11	4	5/16"-18 Nut
12	10	1/4"-20 Nylon Lock Nut
13	10	1/4"-20 x 1-1/2" Bolt



# Unpack Contents

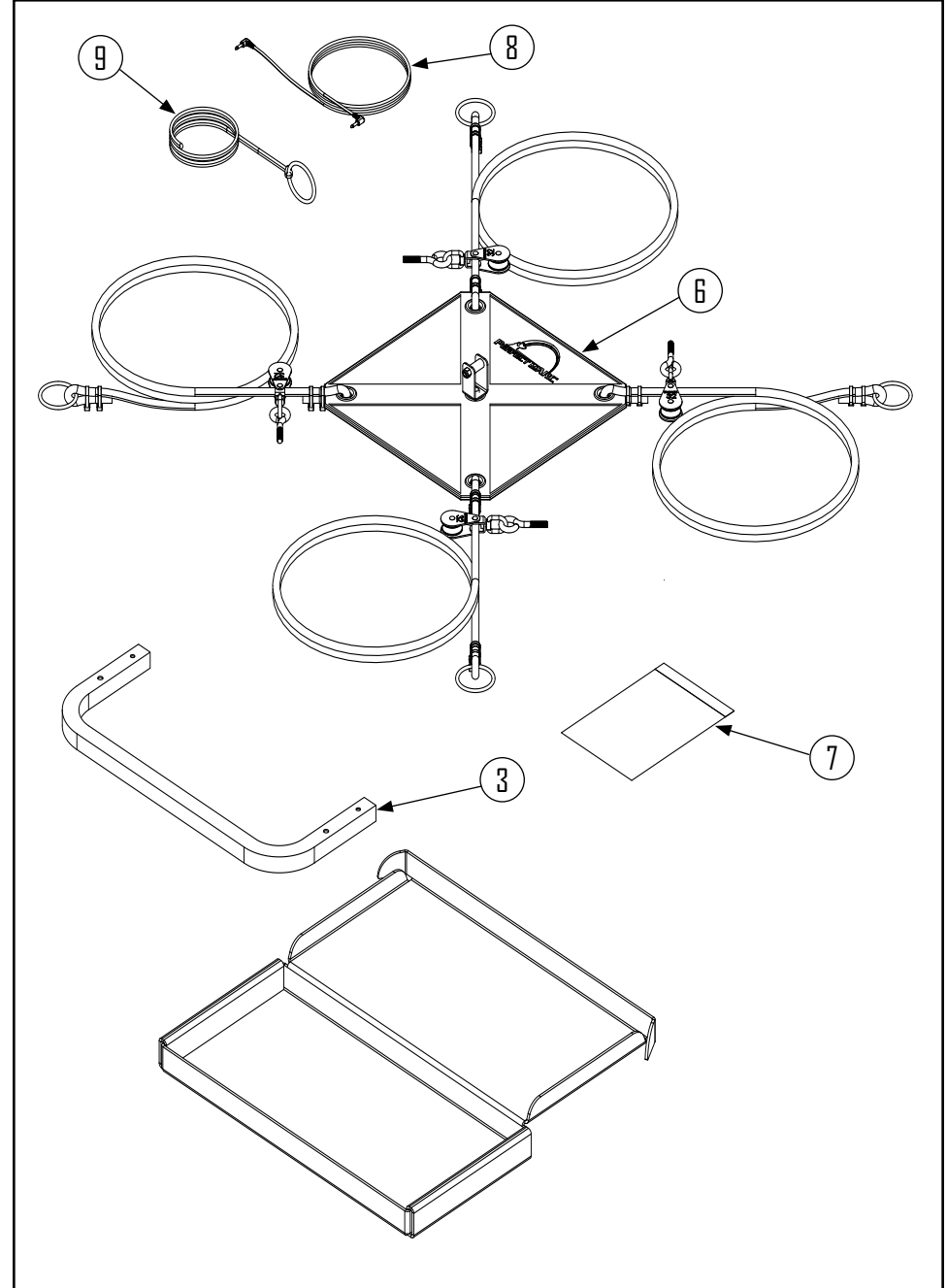
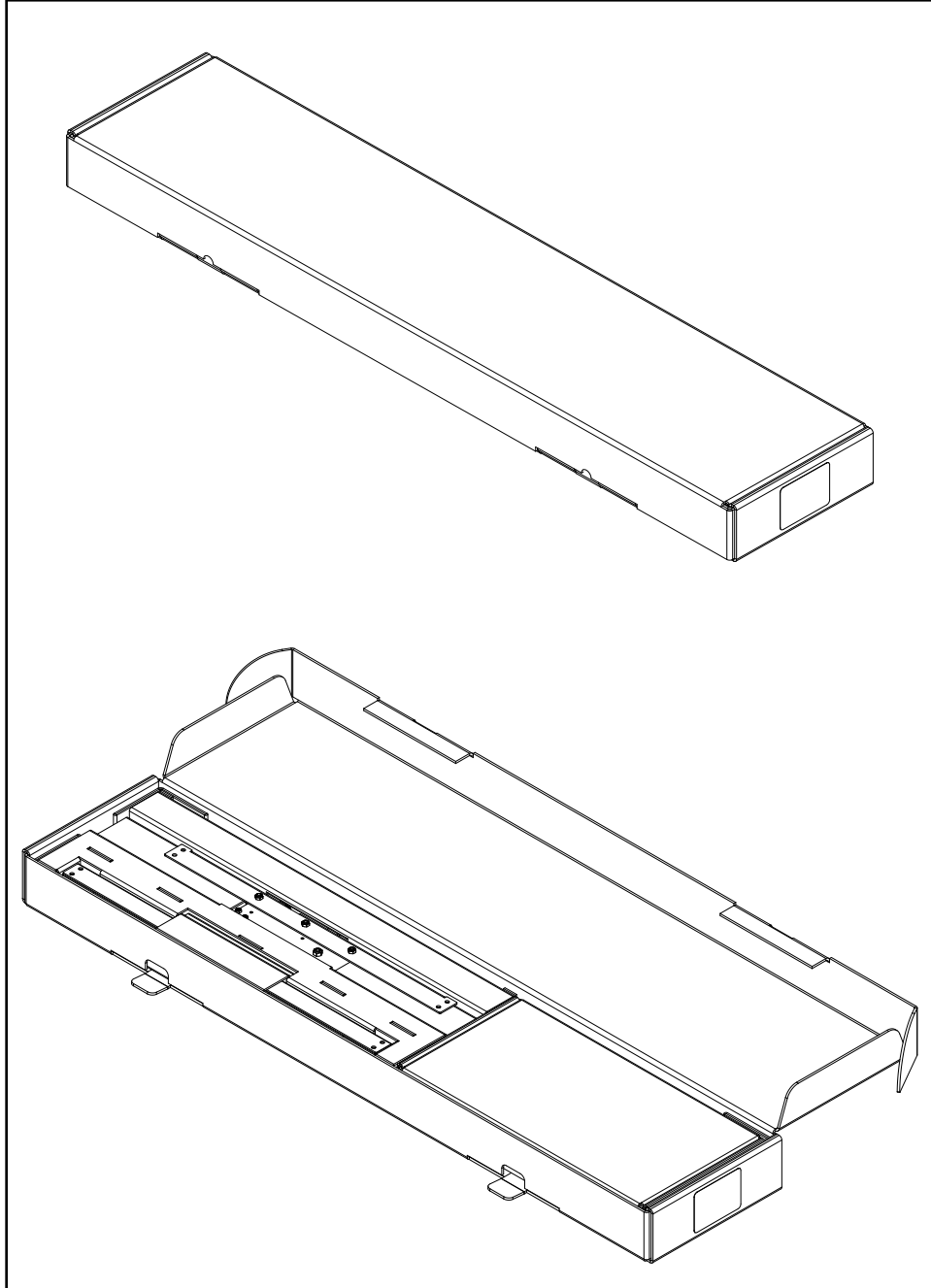



# Unpack Contents

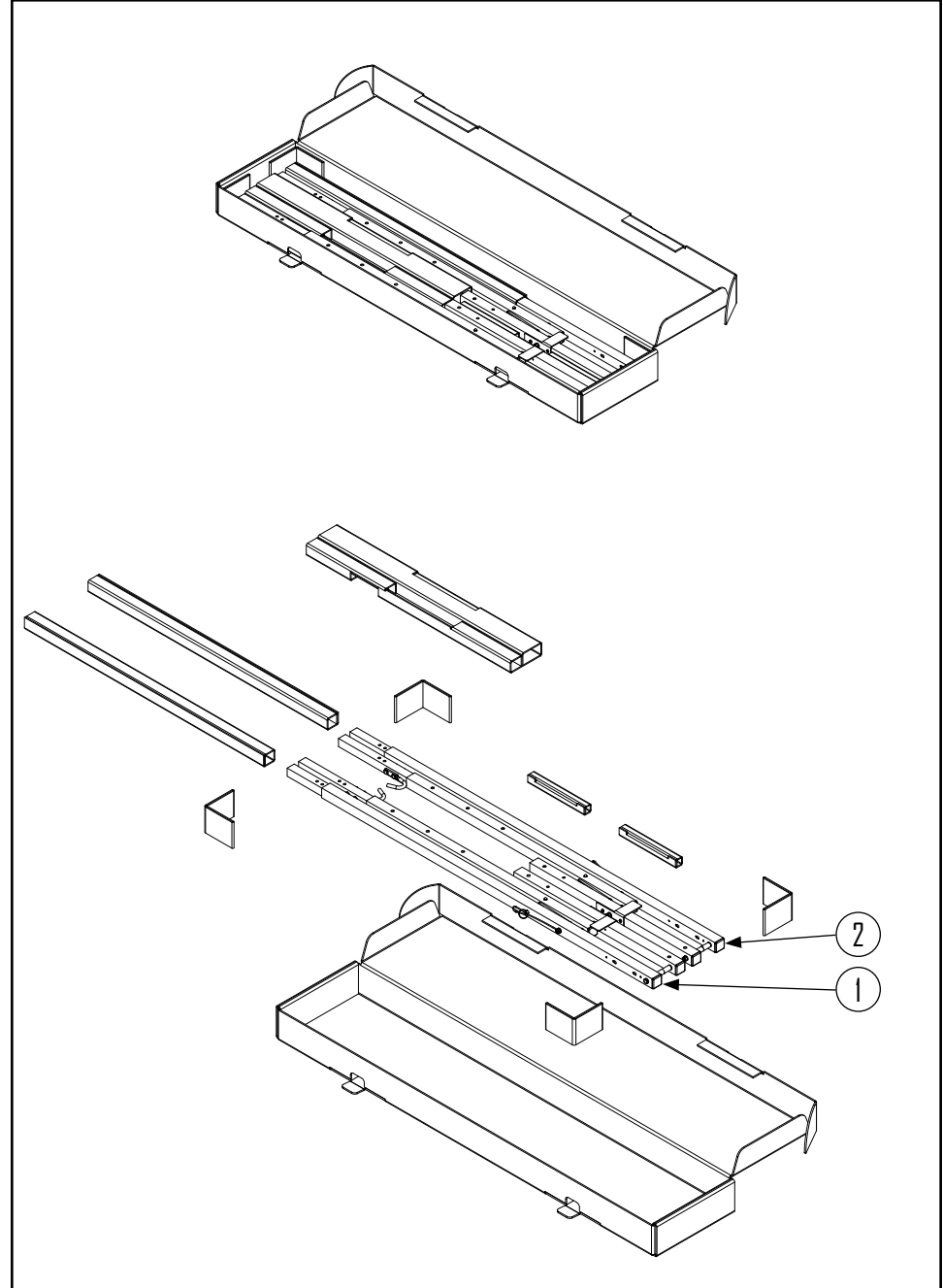
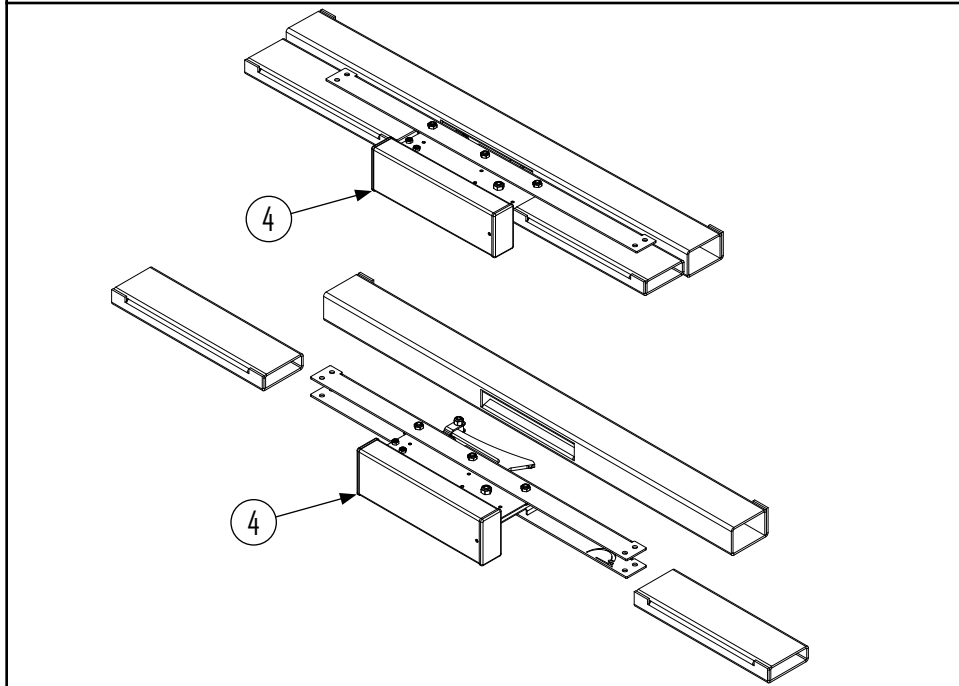
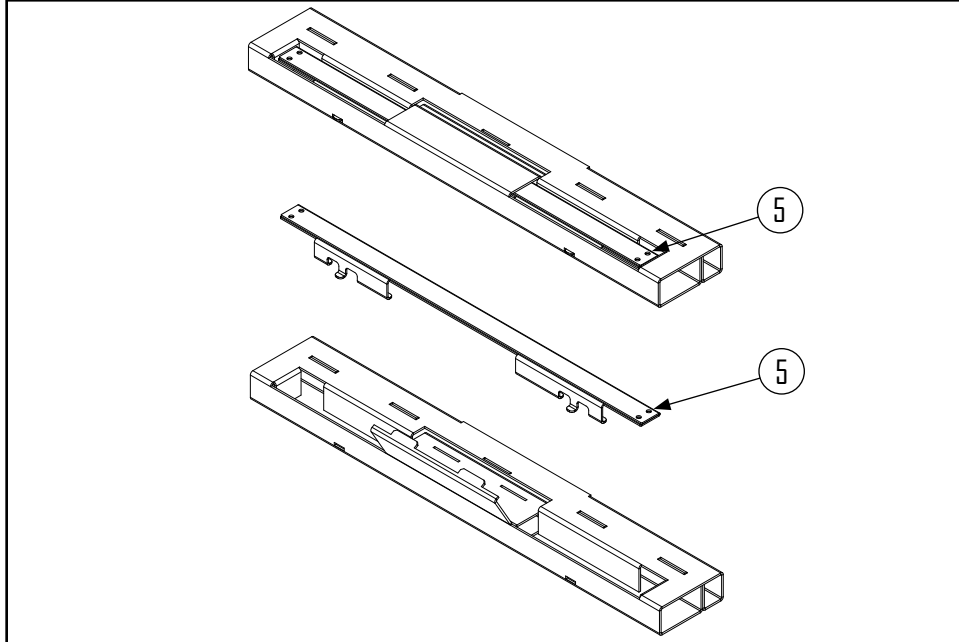



## Assemble the U-Brace to Leg Assemblies



1. Place the Right Leg (Item 1) and the Left Leg (Item 2) Assemblies on flat surface such that the hooks face each other as shown.
2. Position the U-Brace (Item 5) between the Right Leg (Item 1) and Left Leg (Item 2) the Assembly
3. Align the U-Brace (Item 5) with the tubing of both legs as shown.
4. Insert the U-Brace (Item 5) into the tubing of both legs until all four holes are aligned.

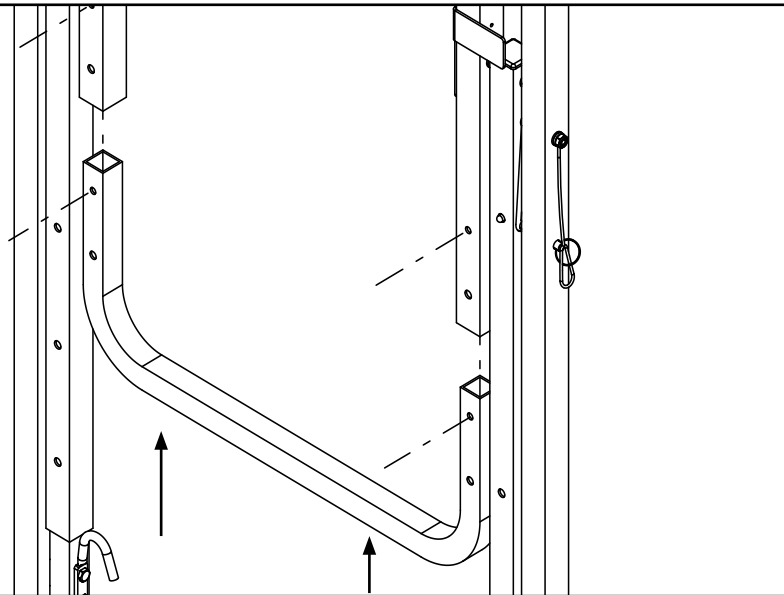
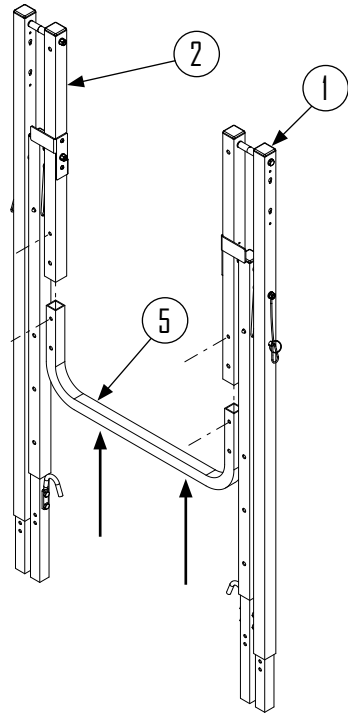

5. Insert (2) 1/4"-20 x 1-1/2" Bolts (Item 13) through the holes shown such that the bolt heads are on the same side of the legs as the inner spring buttons. Ensure that the U-Brace (Item 5) is fully inserted into the Right Leg (Item 1) and Left (Item 2) Assemblies.
6. Thread (2) 1/4"-20 Nylon Lock Nuts (Item 12) onto the (2) 1/4"-20 x 1-1/2" Bolts (Item 13). Do NOT tighten at this step.

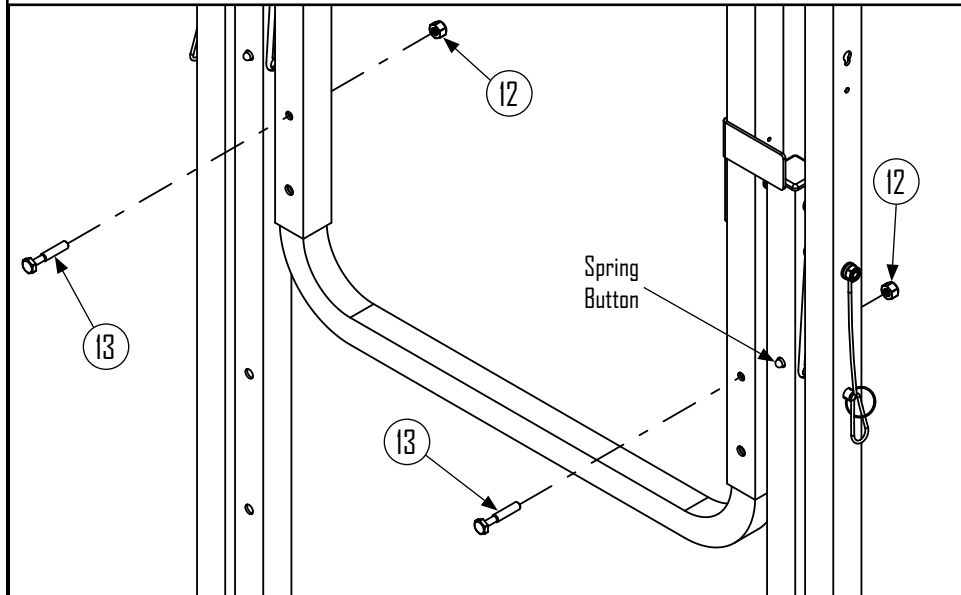
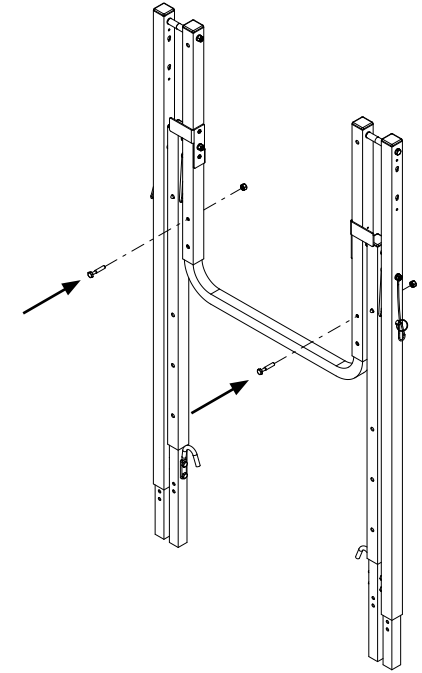



# Assemble the Trigger Brace Assembly



1. Stand the assembly upright with the inner spring button and holes facing you.
2. Pull out (2) QR (quick release) pins.

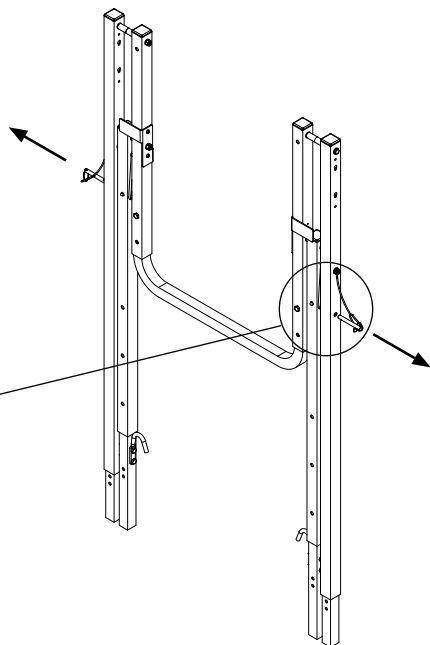
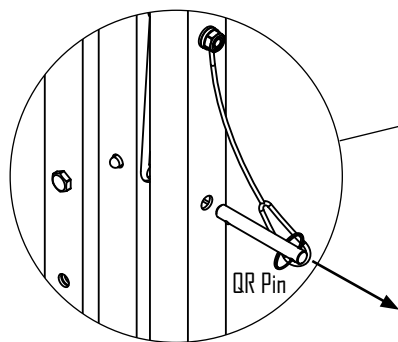

3. With both hands on the top of the outer legs, simultaneously unfold the legs slightly. The assembly will NOT unfold completely with the throwing column retracted to the storage position.

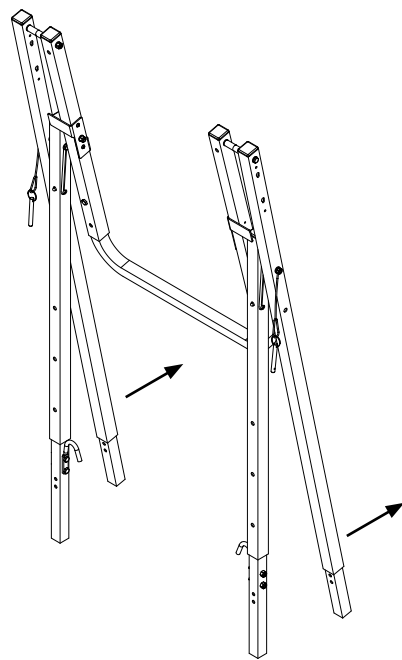

4. Position the Trigger Brace Assembly (Item 4) so that the wider side of the housing is facing out and slide onto the Right Leg (Item 1) and Left Leg (Item 2) Assembly column tubing aligning the (4) holes as shown.
5. Insert (4) 1/4"-20 x 1-1/2" Bolts (Item 12) through the holes as shown.
6. Thread (4) 1/4"-20 Nylon Lock Nuts (Item 11) onto the (4) 1/4"-20 x 1-1/2" Bolts (Item 12). Do NOT tighten at this step.

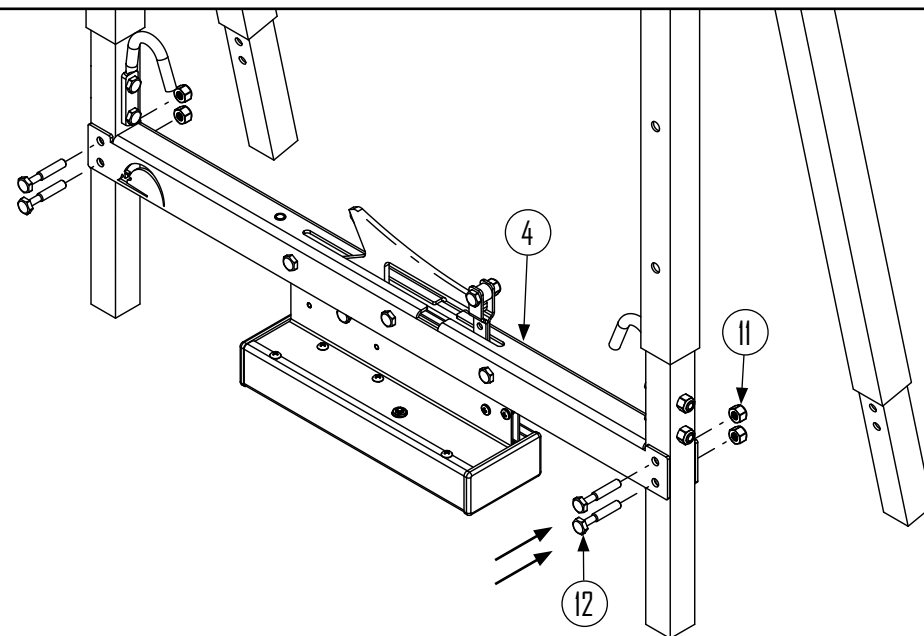
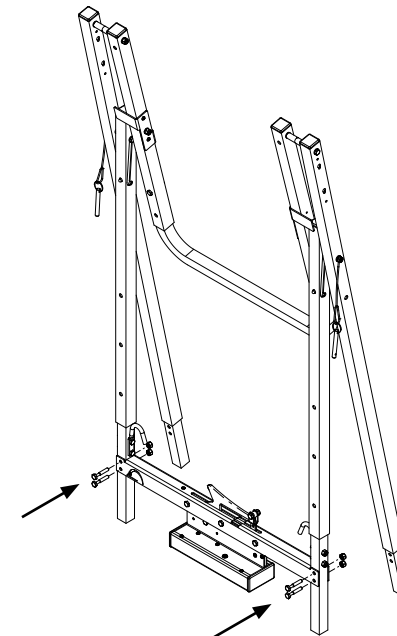



## Assemble the Leg Brace

1. Align the Leg Brace (Item 5) with the leg holes such that the CrossKeeper Ring Tabs are facing towards the inside of the assembly as shown.
2. Insert (4) 1/4"-20 x 1-1/2" Bolts (Item 13) through the leg holes as shown.
3. Thread (4) 1/4"-20 Nylon Lock Nuts (Item 12) onto the (4) 1/4"-20 x 1-1/2" Bolts (Item 13).
4. Tighten (8) 1/4"-20 Nylon Lock Nuts (Item 12) on Trigger Brace (Item 4) and Leg Brace (Item 5) with 7/16" wrenches.

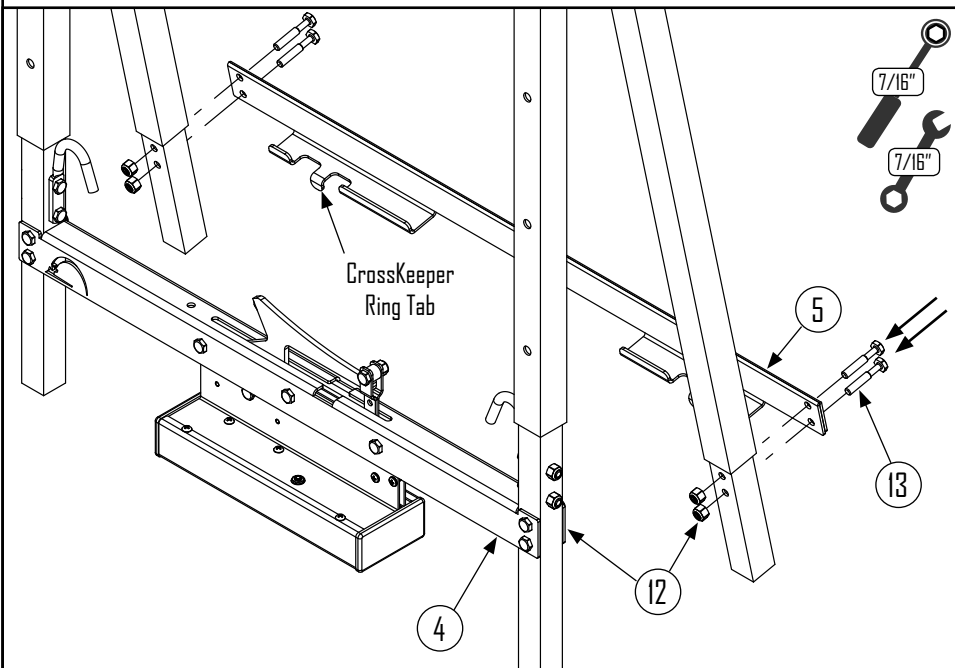
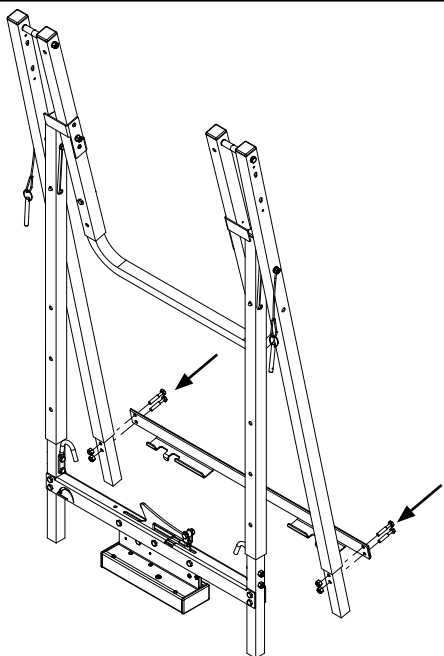

## Extend the Assembly



1. Positioned facing the trigger assembly, extend the throwing columns by simultaneously pressing the (2) spring buttons and lifting the assembly until the buttons spring out of the next hole position.

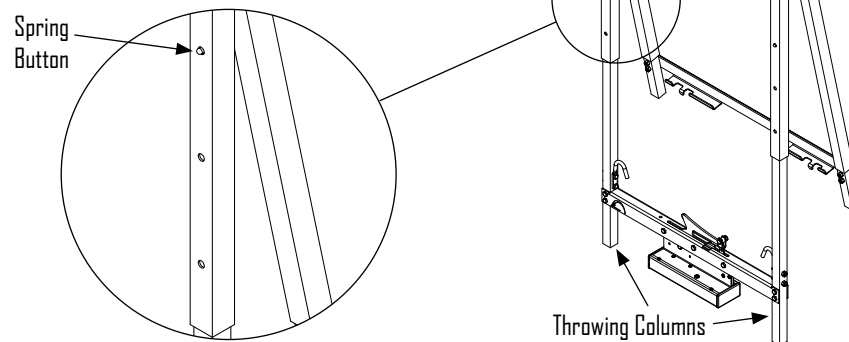

2. With both hands on the top of the outer legs, simultaneously unfold until the legs slide forward and stop. The leg bolts will slide to the end of the SlotSlide groove in the frame and cease movement.
3. Carefully set the assembly on all four legs.

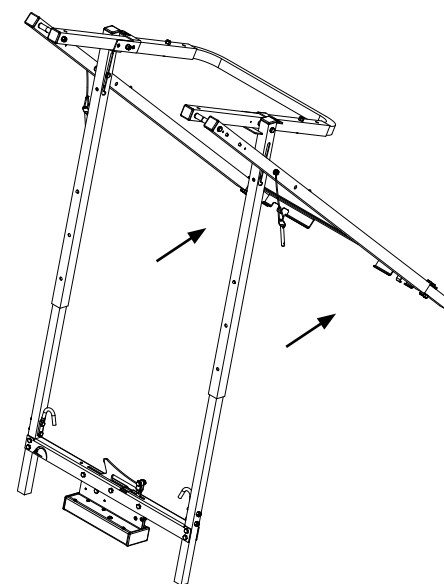





## Lock Frame Into Extended Position



### WARNING

Failure to insert the (2) QR (quick release) pins can result in personal injury during the loading process. The engagement of the QR pins is critical to the mechanism stability during the loading process.

1. With both leg bolts seated in the SlotSlide groove as depicted, insert (2) QR pins through the column frame holes above the leg bolt seated in the SlotSlide groove.

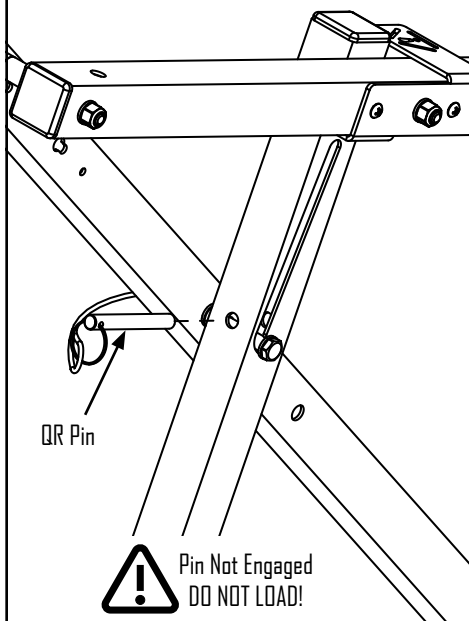
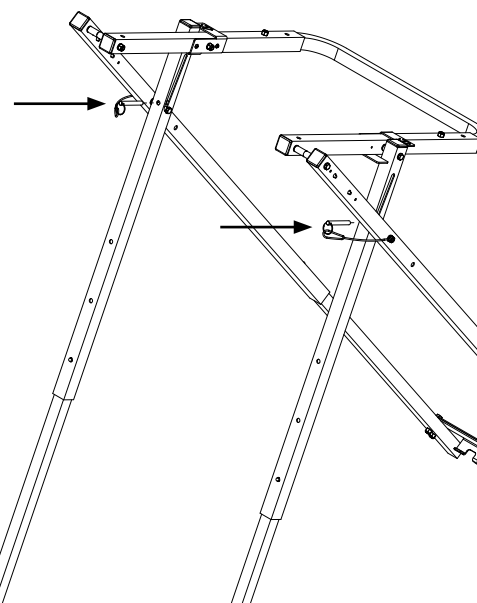

Pin Not Engaged  
DO NOT LOAD!

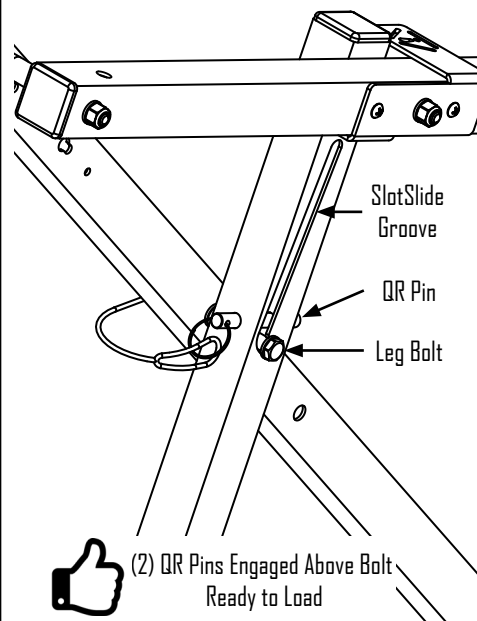

(2) QR Pins Engaged Above Bolt  
Ready to Load



## Install Pouch Assembly



1. Position the Pouch Assembly (Item 6) so that the roller bracket is parallel to the trigger arm and the logo on the pouch is outward as shown.
2. Insert (4) eyebolts up through the U-Brace holes as depicted.
3. Place (4) 5/16" Lock Washers (Item 10) and thread (4) 5/16"-18 Nuts (Item 11) onto eyebolts.
4. Tighten (4) 5/16"-18 Nuts (Item 11) using a 1/2" wrench and screw driver to hold the eyebolt parallel to the U-Brace.
5. Tighten (2) 1/4"-20 Nylon Lock Nuts (Item 12) using a 7/16" wrench and ratchet.

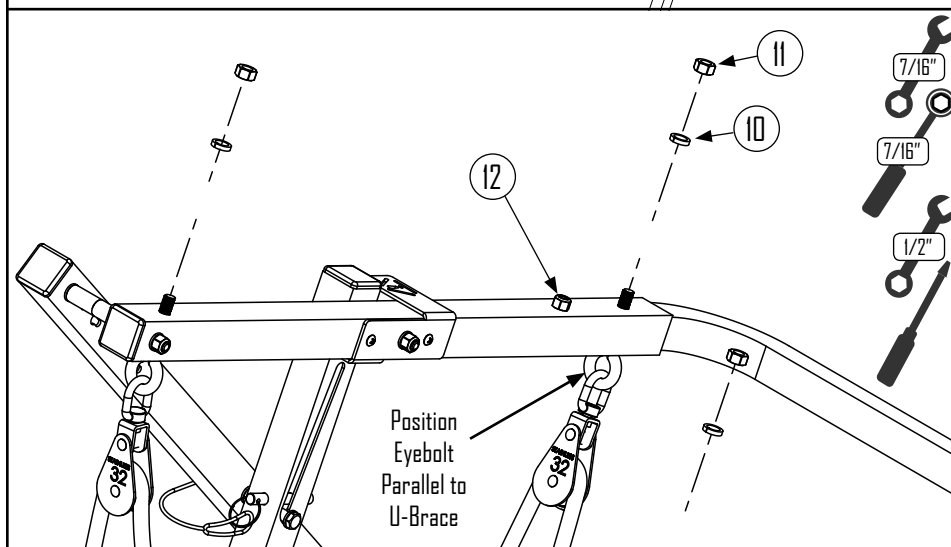
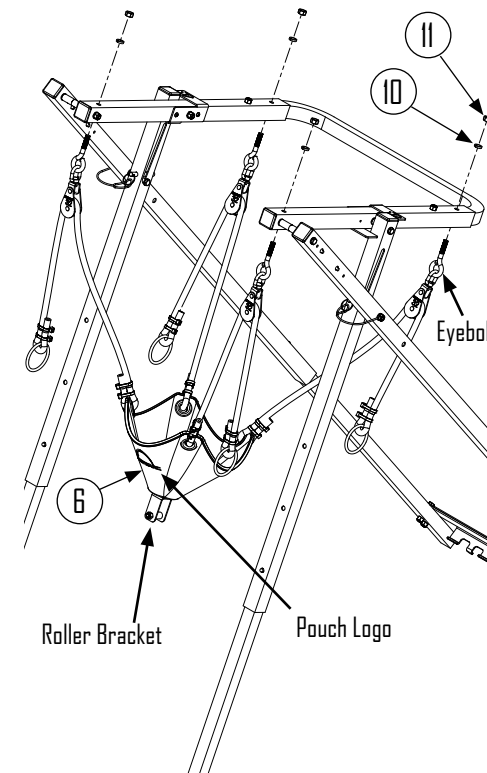



# Retract and Fold Assembly



1. Retract the throwing column legs by simultaneously pressing in the spring pins and moving the legs up into the frame until the spring pins move past the third set of holes. When folded flat the spring pins will emerge from the quick release pin holes.
2. Retract the legs similarly until the spring pins emerge from the upper most holes.
3. Disengage the (2) QR pins.
4. Fold the assembly until the spring pins on the throwing columns spring from the holes in which the quick release pins were installed when fully extended. Continue to fold the launcher flat, ensuring the elastics are not pinched in the assembly.

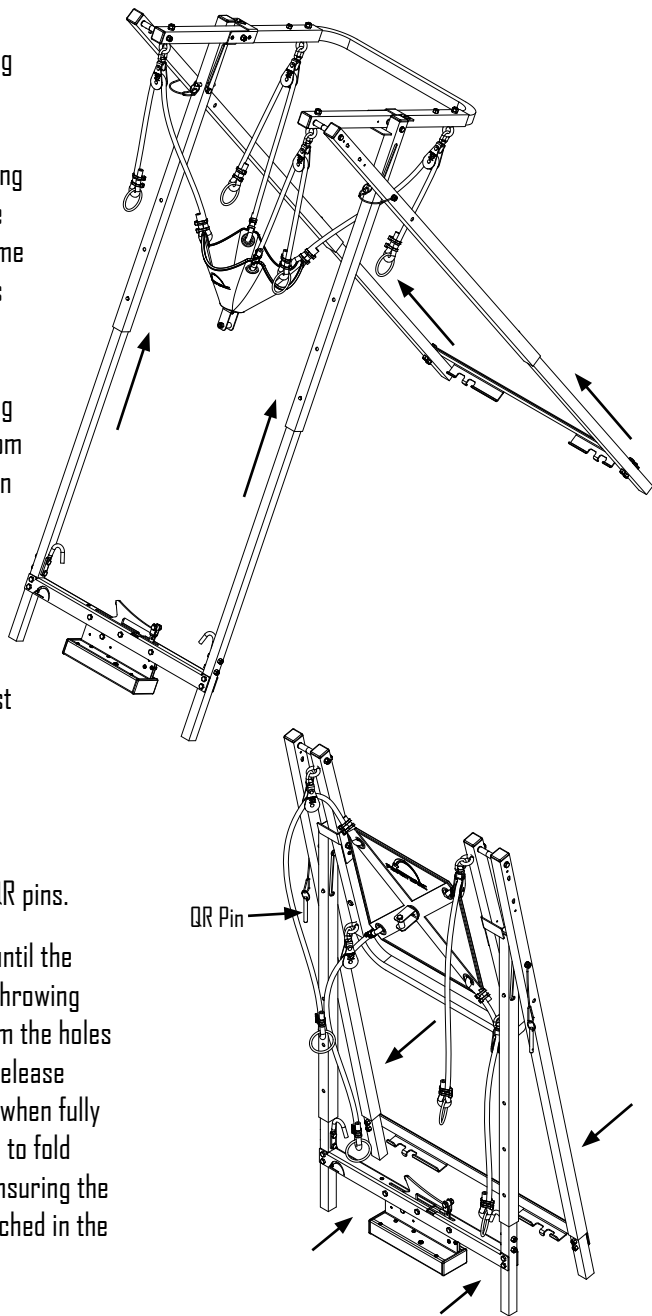

5. With the assembly folded flat, insert the (2) QR pins into the side holes of the leg assemblies.
6. Hook the rings from top most elastics to the anchor hooks opposite of the pulley it is through.
7. Hook the rings of from the bottom elastics to the CrossKeeper ring tabs on the leg brace such that they cross each other as shown below.

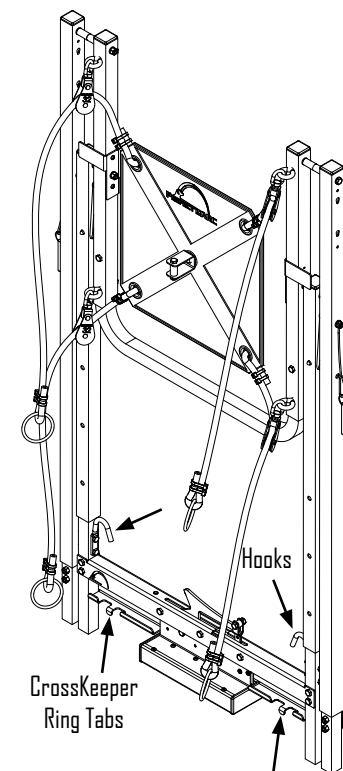
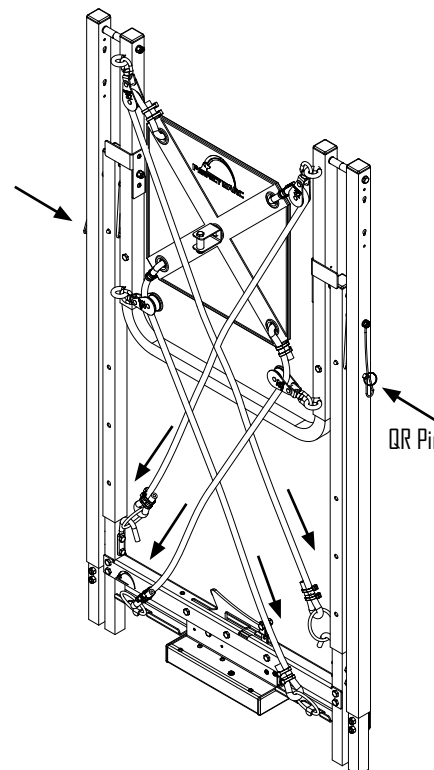

Congratulations, you have successfully assembled a valuable tool which will help you and your dog TRAIN. TEST. TITLE.

Be sure to review the user manual to get familiar with the operation and care of your remote throwing system.



Need a hey, hey, hey?  
470.297.8788

Visit Us  
[www.perfectmarc.com](http://www.perfectmarc.com)

Follow Us

