

NO.	SPECIFICATION	QTY	REMARK
1	SPT-2 18/2C 105°C BLACK	1PC	1820±15(YL)
2	YP-11 INNER BODY	1PC	
3	YP-11 PVC PLASTIC:35P BLACK	15g/PC	
4	TER:98675BS-1	2PCS	
5	YC-13 PVC PLASTIC:50P BLACK	9g/PC	
6	YC-13 H. S. G	1PC	
7	YC-13 TER	2PCS	
8	MINI TIE:L=110mm BLACK	1PC	
9	SLEEVE WHITE	1PC	

TOLERANCE >0.0±0.30 >1.0±0.50 >10.0±1.0 >20.0±2.0 Angle: ±1°	APPROVED	<i>Avo Landre</i>	DATE	06-07-2023	SIGNAL+POWER			
	CHECKED		DATE					
	DRAWN	H F	DATE	22.07.01	CUSTOMER			
	TYPE	YP-11/YC-13			P/N	P-ZIP-06-EN		
	DRAWING NO.	CY-U0003-48	REV	B	MATERIAL	P. V. C	UNIT	mm
				HEFT(g)	90			

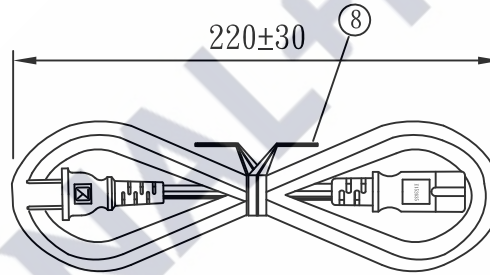

(15') 4570±80

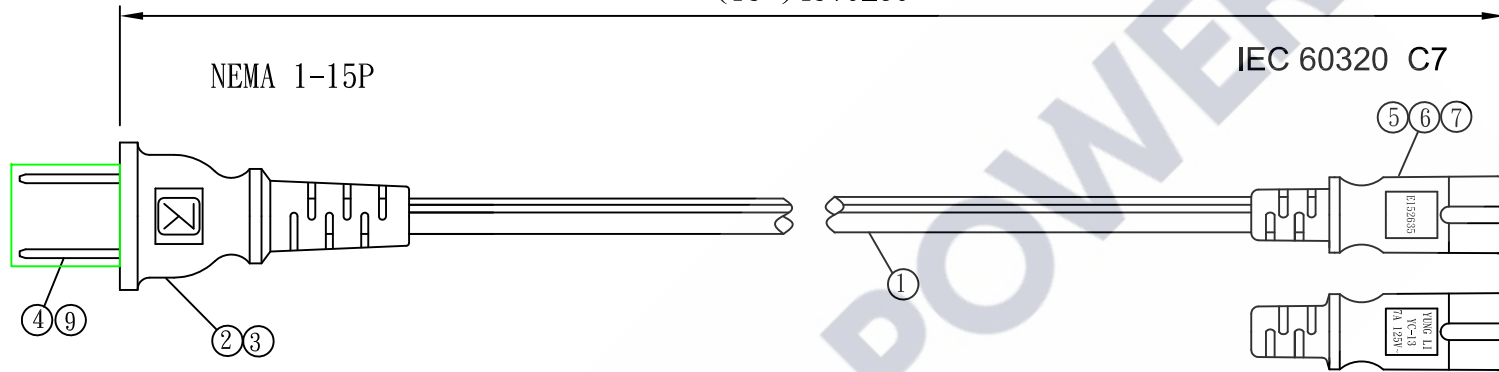

NO.	SPECIFICATION	QTY	REMARK
1	SPT-2 18/2C 105°C BLACK	1PC	
2	YP-11 INNER BODY	1PC	
3	YP-11 PVC PLASTIC:35P BLACK	15g/PC	
4	TER:98675BS-1	2PCS	
5	YC-13 PVC PLASTIC:50P BLACK	9g/PC	
6	YC-13 H. S. G	1PC	
7	YC-13 TER	2PCS	
8	MINI TIE:L=150mm BLACK	1PC	
9	SLEEVE WHITE	1PC	

TOLERANCE >0±0.30 >1.0±0.50 >10.0±1.0 >20.0±2.0 Angle: ±1°	APPROVED	<i>Ivo Landro</i>	DATE	06-07-2023	SIGNAL+POWER			
	CHECKED		DATE					
	DRAWN	SUKI	DATE	22.09.06	CUSTOMER			
	TYPE	YP-11/YC-13		P/N	P-1113-15B			
	DRAWING NO.	CY-U5020	REV	C	MATERIAL	P. V. C	UNIT	mm
				HEFT(g)	198			