

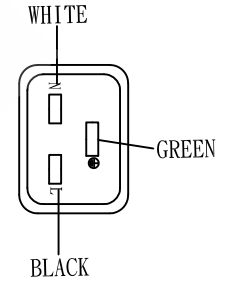

(6')1830±50

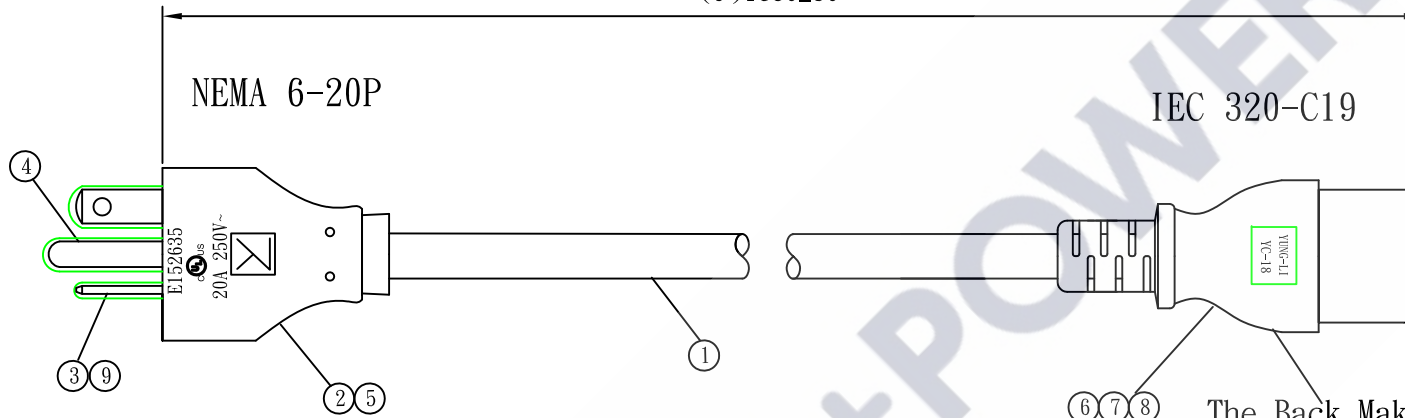

The Back Making
E152635
20A 250V~

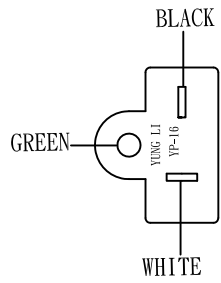
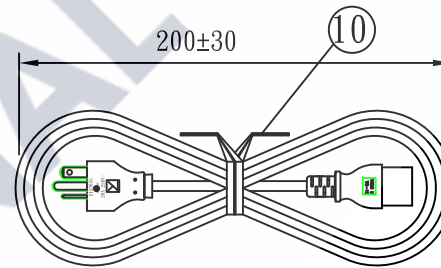

NO.	SPECIFICATION	QTY	REMARK
1	SJT 12/3C 105°C BLACK	1PC	
2	YP-16 PVC PLASTIC:35P BLACK	27g/PC	
3	TER:98673BS-1	2PCS	
4	TER:98475BS-1	1PC	
5	YP-16 INNER BODY	1PC	
6	YC-18 PVC PLASTIC:50P BLACK	25g/PC	
7	YC-18 INNER BODY	1PC	
8	YC-18 TER	3PCS	
9	SLEEVE:3PIN WHITE	1PC	
9	MINI TIE:L=180mm BLACK	1PC	

Tolerance >0±0.30 >1.0±0.50 >10.0±1.0 >20.0±2.0 Angle: ±1°	Approved		Date		SIGNAL+POWER			
	Checked		Date					
	Drawn	SUKI	Date	22.09.05	Customer			
	Cat. No.	YP-16/YC-18			P/N.	P-1618-06B		
	Drawing No.	CY-U4731	Rev.	C	Material	P. V. C	Unit	mm
				Scale				



(10') 3050±50

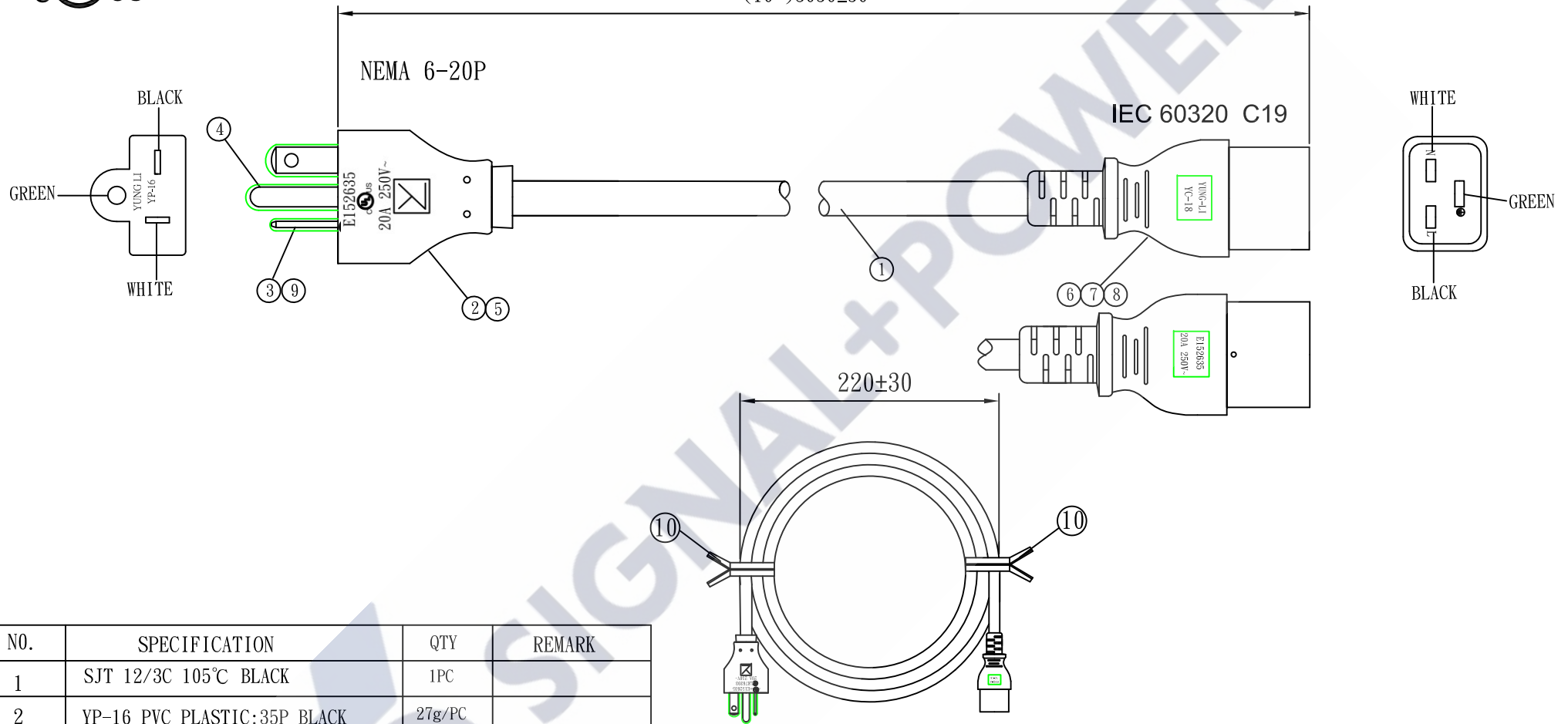

NO.	SPECIFICATION	QTY	REMARK
1	SJT 12/3C 105°C BLACK	1PC	
2	YP-16 PVC PLASTIC:35P BLACK	27g/PC	
3	TER:98695BS-1	2PCS	
4	TER:98473BS-1	1PC	
5	YP-16 INNER BODY	1PC	
6	YC-18 PVC PLASTIC:50P BLACK	25g/PC	
7	YC-18 INNER BODY	1PC	
8	YC-18 TER	3PCS	
9	SLEEVE:3PIN WHITE	1PC	
10	MINI TIE BLACK	2PCS	

TOLERANCE >0±0.30 >1.0±0.50 >10.0±1.0 >20.0±2.0 Angle: ±1°	APPROVED		DATE		SIGNAL+POWER			
	CHECKED		DATE					
	DRAWN		DATE		CUSTOMER			
	TYPE	YP-16/YC-18			P/N	P-1618-10B		
	DRAWING NO.		REV	B	MATERIAL	P. V. C	UNIT	mm
				SCALE				

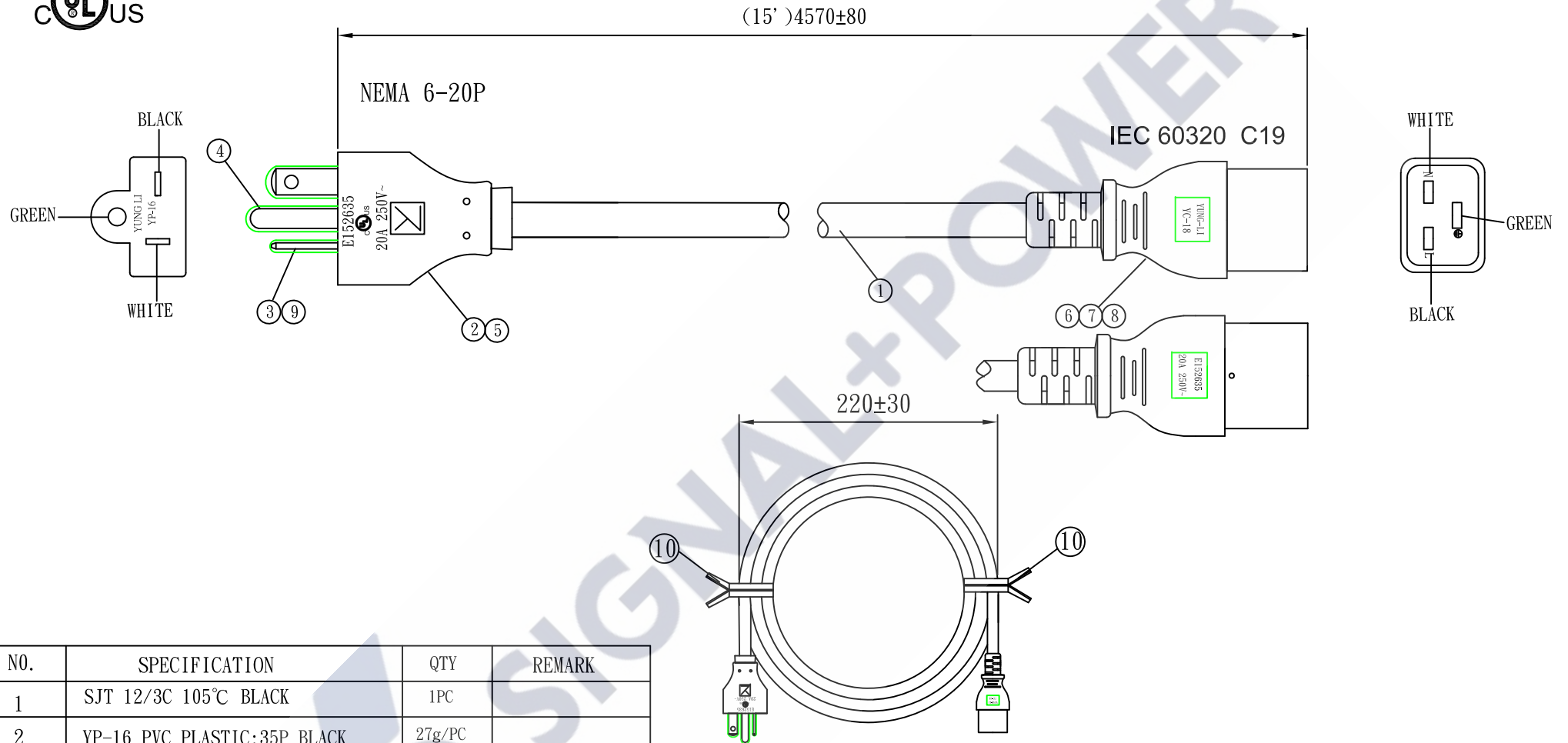

NO.	SPECIFICATION	QTY	REMARK
1	SJT 12/3C 105°C BLACK	1PC	
2	YP-16 PVC PLASTIC:35P BLACK	27g/PC	
3	TER:98695BS-1	2PCS	
4	TER:98473BS-1	1PC	
5	YP-16 INNER BODY	1PC	
6	YC-18 PVC PLASTIC:50P BLACK	25g/PC	
7	YC-18 INNER BODY	1PC	
8	YC-18 TER	3PCS	
9	SLEEVE:3PIN WHITE	1PC	
10	MINI TIE BLACK	2PCS	

TOLERANCE >0±0.30 >1.0±0.50 >10.0±1.0 >20.0±2.0 Angle: ±1°	APPROVED		DATE		SIGNAL+POWER			
	CHECKED		DATE					
	DRAWN	SUKI	DATE	22.09.20	CUSTOMER			
	TYPE	YP-16/YC-18			P/N	P-1618-15B		
	DRAWING NO.	CY-U2051-02	REV	B	MATERIAL	P. V. C	UNIT	mm
				SCALE				