

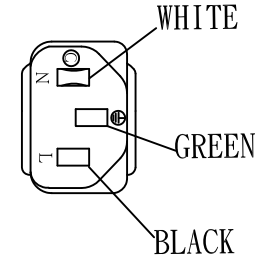

(3') 915±30

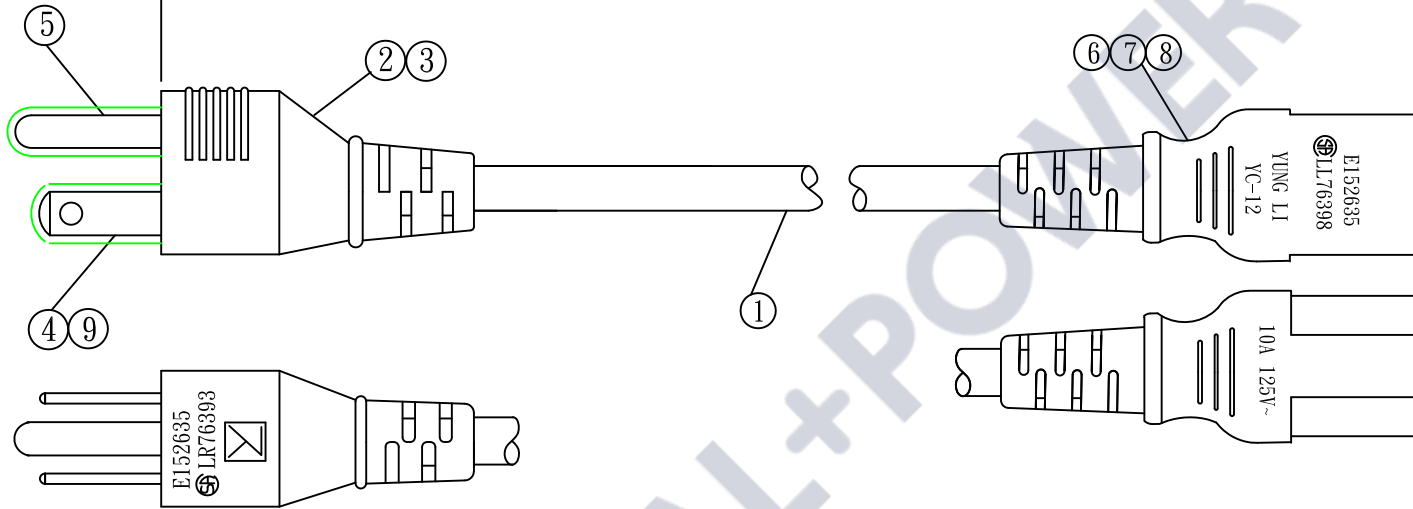
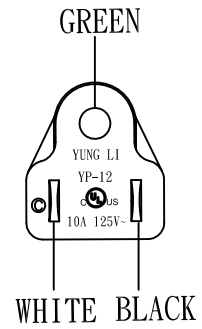

Packing: Bulk Pack.

NO.	SPECIFICATION	QTY	REMARK
1	SVT 18/3C 105°C BLACK	1PC	
2	YP-12 PVC PLASTIC:50P BLACK	19g/PC	
3	YP-12 INNER BODY	1PC	
4	TERMINAL:98675BS-1	2PCS	
5	TERMINAL:98475	1PC	
6	U-TYPE TERMINAL:97740BS-0	3PCS	
7	YC-12 PVC PLASTIC:50P BLACK	18g/PC	
8	YC-12 INNER BODY	1PC	
9	SLEEVE	1PC	

TOLERANCE >0±0.30 >1.0±0.50 >10.0±1.0 >20.0±2.0 Angle: ±1°	APPROVED		DATE				
	CHECKED		DATE				
	DRAWN		DATE		CUSTOMER		
	TYPE	YP-12/YC-12			P/N	P-1212-03B	
	DRAWING NO.	CY-U1530-01	REV	C	MATERIAL	P. V. C	UNIT mm
				SCALE			

You will not be informed separately if we change any marking or indication on cables according with approval organization ' s requirement !

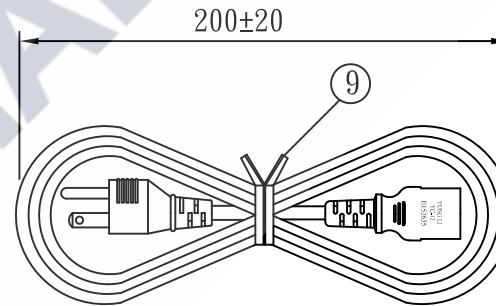
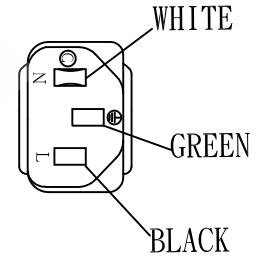
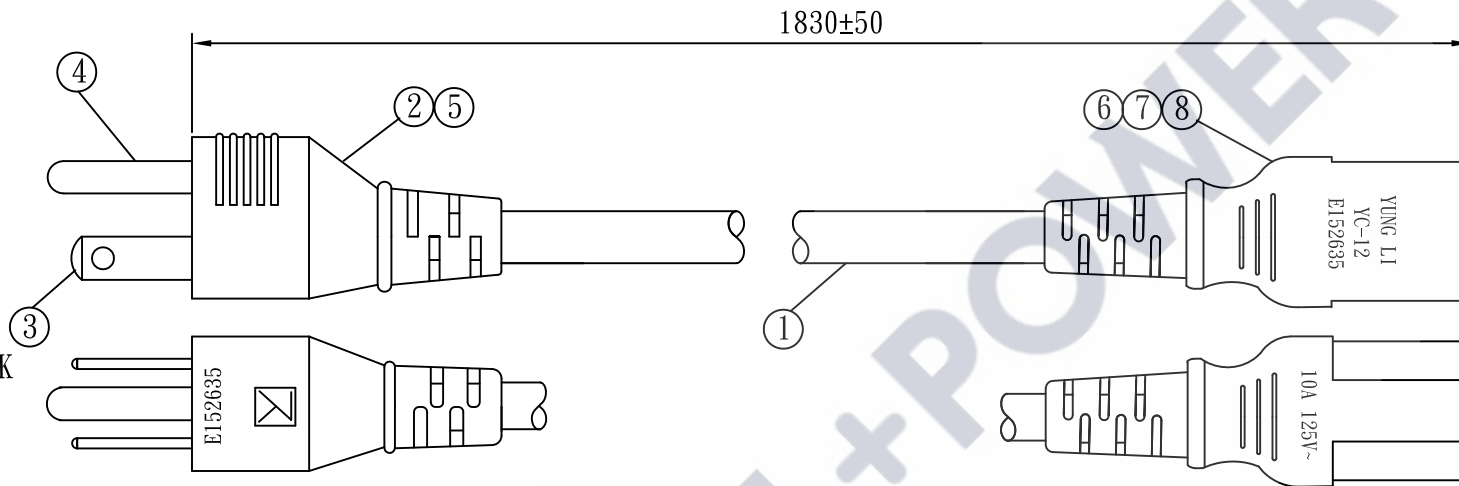
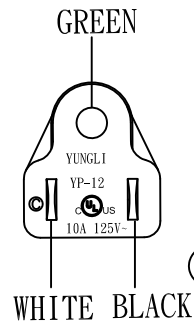

NO.	SPECIFICATION	QTY	REMARK
1	SVT 18/3C 105°C BLACK	1PC	
2	YP-12 PVC PLASTIC 35P BLACK	19g/PC	
3	TERMINAL:98675BS-1	2PCS	
4	Ø4.75 TERMINAL:98475	1PC	
5	YP-12 INNER BODY	1PC	
6	YC-12 PVC PLASTIC 50P BLACK	18g/PC	
7	U-TYPE TERMINAL:97740	3PCS	
8	YC-12 INNER BODY	1PC	
9	MINI TIE:L=130mm BLACK	1PC	

Tolerance >0±0.30 >1.0±0.50 >10.0±1.0 >20.0±2.0 Angle: ±1°	Approved	Date		<b>SIGNAL+POWER</b>			
	Checked	Date					
Drawn	H.F	Date	22.08.04	P/N.	P-06B-EN		
Cat. No.	YP-12/YC-12			Material	P.V.C	Unit	mm
Drawing No.	CY-U0032-60	Rev.	C	Scale			

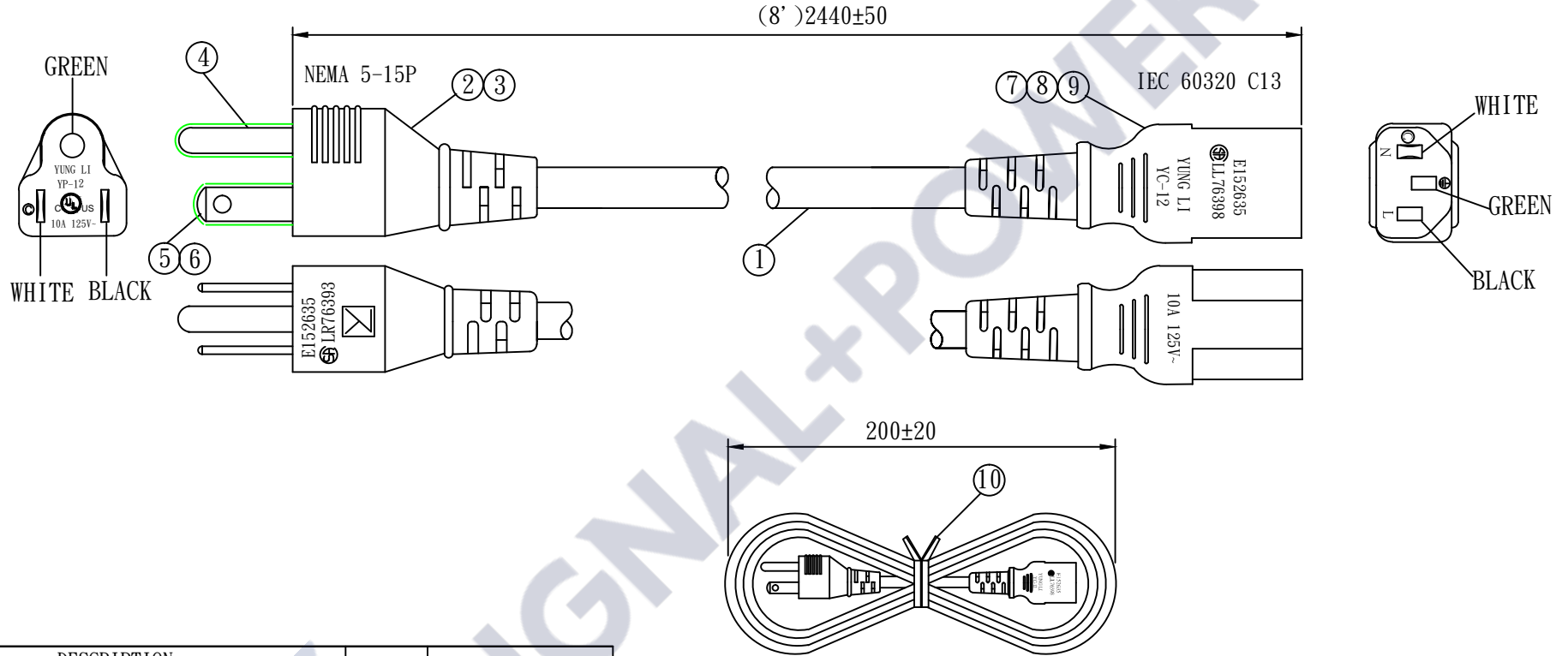

NO.	DESCRIPTION	QTY	REMARK
1	SVT 18/3C 105°C BLACK	1PC	
2	YP-12 PVC PLASTIC 35P BLACK	19g/PC	
3	YP-12 INNER BODY	1PC	
4	TERMINAL:98475	1PC	
5	TERMINAL:98675BS-1	2PCS	
6	SLEEVE	1PC	
7	YC-12 PVC PLASTIC 50P BLACK	18g/PC	
8	U-TYPE TERMINAL:97740	3PCS	
9	YC-12 INNER BODY	1PC	
10	MINI TIE:L=150mm BLACK	1PC	

Tolerance >0±0.30 >1.0±0.50 >10.0±1.0 >20.0±2.0 Angle: ±1°	Approved	Date	SIGNAL+POWER			
	Checked	Date	Customer	P/N. P-1212-08B		
Drawn	Date	Material	P. V. C	Unit	mm	
Cat. No.	YP-12/YC-12		HEFT(g)			
Drawing No.	CY-U1156-01	Rev.	C			

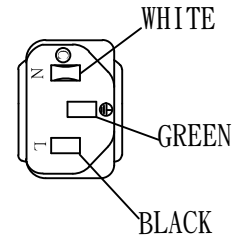
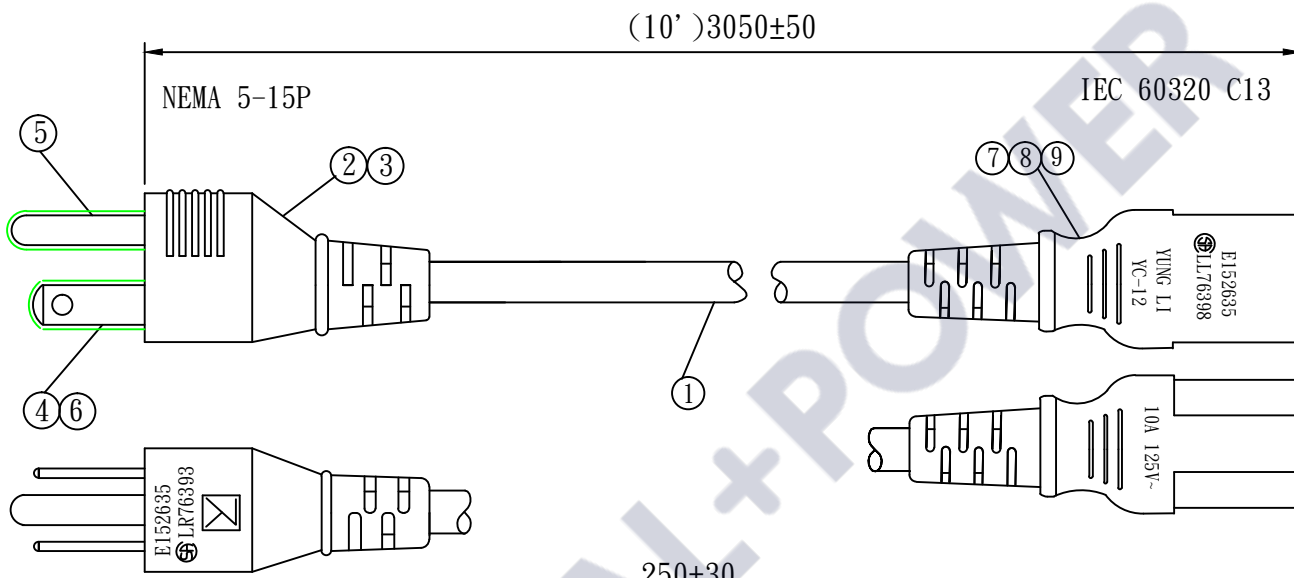
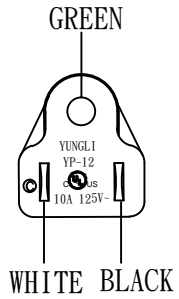

NO.	DESCRIPTION	QTY	REMARK
1	SVT 18/3C 105°C BLACK	1PC	
2	YP-12 PVC PLASTIC:50P BLACK	19g/PC	
3	YP-12 INNER BODY	1PC	
4	TERMINAL:98675BS-1	2PCS	
5	TERMINAL:98475	1PC	
6	SLEEVE	1PC	
7	U-TYPE TERMINAL:97740BS-0	3PCS	
8	YC-12 PVC PLASTIC:50P BLACK	18g/PC	
9	YC-12 INNER BODY	1PC	
10	MINI TIE: L=200mm BLACK	1PC	

TOLERANCE >0±0.30 >1.0±0.50 >10.0±1.0 >20.0±2.0 Angle: ±1°	APPROVED	DATE	SIGNAL+POWER			
	CHECKED	DATE	CUSTOMER			
DRAWN	DATE	P/N	P-1212-10B			
TYPE	YP-12/YC-12		MATERIAL	P. V. C	UNIT	mm
DRAWING NO.	CY-U0781-04	REV	C	SCALE		