

CLENCH ™

FOOTPLATE RISER KIT

INSTALLATION GUIDE

INSTALLATION INSTRUCTIONS:

1. ALIGN RUBBER FOOT (2) WITH MOUNTING HOLES ON FOOTPLATE (1).
2. INSTALL SCREW (4) WITH PHILLIPS SCREWDRIVER, HAND TIGHTEN ONLY. DO NOT OVERTIGHTEN AS MOUNTING HOLE CAN BE PERMANENTLY DAMAGED.
3. REPEAT STEPS 1 & 2 UNTIL ALL 8 RUBBER FEET (2) ARE INSTALLED.

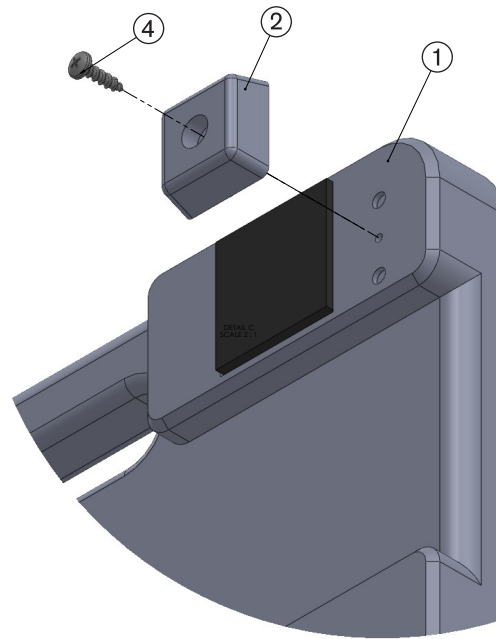
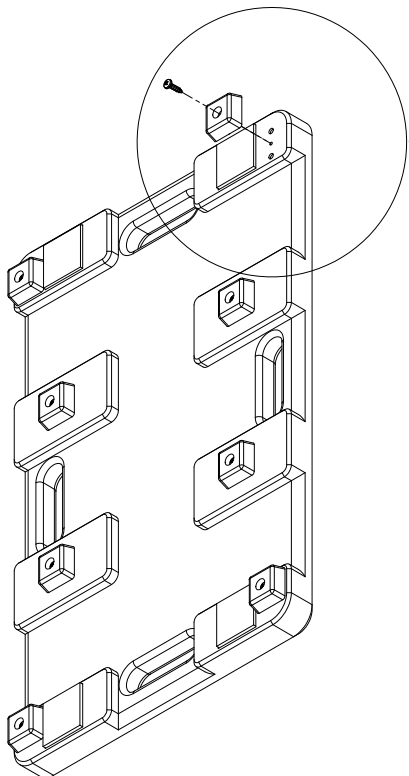

FOR EXERCISES AND WORKOUTS CHECK OUT
[CLENCHFITNESS.COM/VIDEOS](https://www.clenchfitness.com/videos) AND @CLENCHFITNESS

