



HOSE & FITTING

EVOLUTION IN HYDRAULICS

Soumission par courriel - Email Submission

Voici un exemple du courriel que vous devez nous envoyer

Pièce catalogue hydraulique - Page 49 - No. ST14390-06-06
quantité 50

Here is an example of the email you should send us

Hydraulic catalog part - Page 49 - No. ST14390-06-06
quantity 50

ST14390

(SAE J516/ISO 11926)

90° SWIVEL MALE O'RING BOSS TYPE

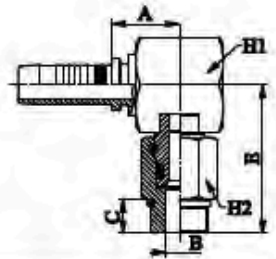

PART. REF.	HOSE BORE			THREAD	DIMENSIONS					
	DN	INCH	SIZE	ORB	B	A	C	E	H1	H2
ST14390 - 06 - 06	10	3/8	- 06	9/16 - 18	7.0	22.8	15.5	46.5	22	22
ST14390 - 06 - 08	10	3/8	- 08	3/4 - 16	7.0	22.8	22.1	51.1	22	27
ST14390 - 08 - 08	12	1/2	- 08	3/4 - 16	9.5	23.0	22.1	51.1	22	27
ST14390 - 08 - 10	12	1/2	- 10	7/8 - 14	9.5	23.0	24.8	53.8	22	27
ST14390 - 10 - 10	16	5/8	- 10	7/8 - 14	12.0	28.0	19.1	52.6	27	27
ST14390 - 12 - 12	19	3/4	- 12	1.1/16 - 12	15.0	30.5	26.2	66.7	32	32

TABLE OF CONTENTS

NUMERICAL INDEX	PAGE(S)
INDEX PRODUCT NUMBER.....	10,
CHARTS	
PAGE(S)	
HOSE INSTALLATION GUIDE.....	3
TWIST ANGLE	4
THREADS IDENTIFICATION.....	5
WORKING PRESSURE ACCORDING TO HOSE TYPE.....	6
WORKING PRESSURE ACCORDING TO THREADS TYPE.....	7
HOW TO MEASURE ASSEMBLIES.....	8
HOSE SECTION	
PAGE(S)	
HOSE.....	12 - 32
HOSE-END SECTION	
PAGE(S)	
"TWO-PIECE" FITTINGS.....	36 - 78
"ONE-PIECE" FITTINGS.....	80 - 157
"A & B SERIES" FITTINGS.....	80 - 121
"C SERIES" FITTINGS.....	122 - 157
REUSABLE HOSE ENDS.....	158 - 165
COMBINATION NIPPLES AND INSERTS.....	168 - 169
PUSH-ON INSERTS.....	170 - 176
ASSEMBLY EQUIPMENT SECTION	
PAGE(S)	
HOSE CRIMPING MACHINES.....	178 - 187
HOSE CUTTING MACHINES SKIVERS AND HOSE RACK.....	187 - 191

Hose Installation Guide

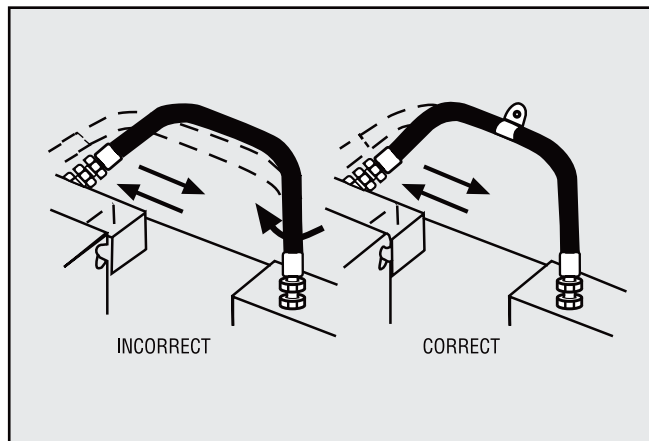
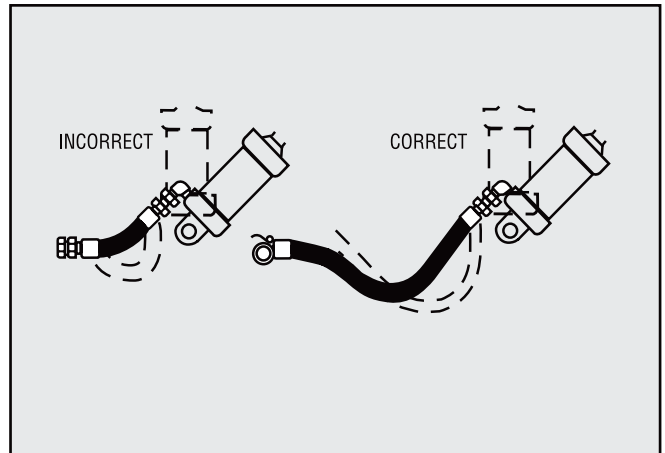
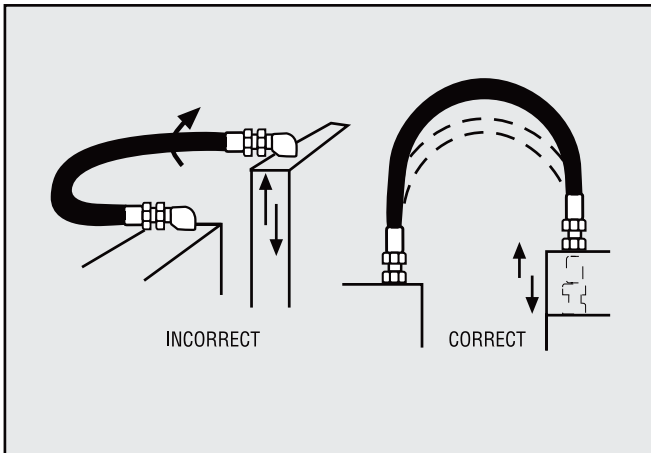
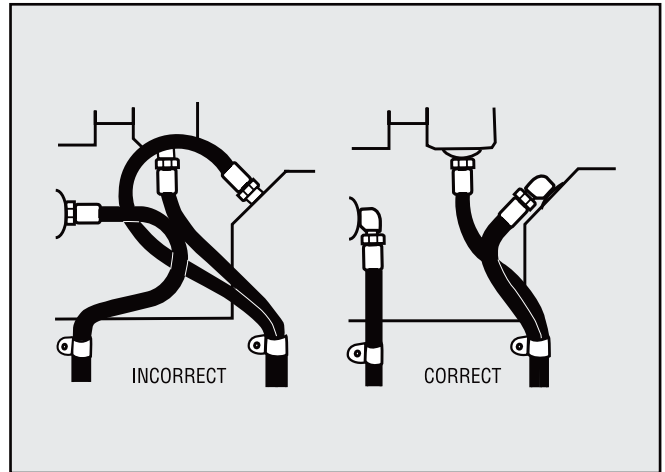
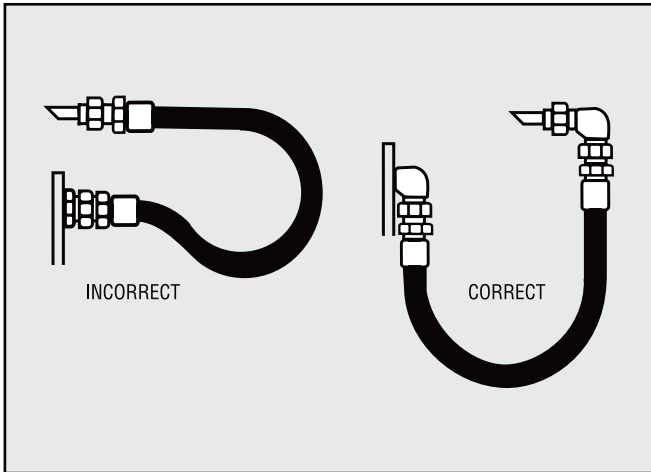
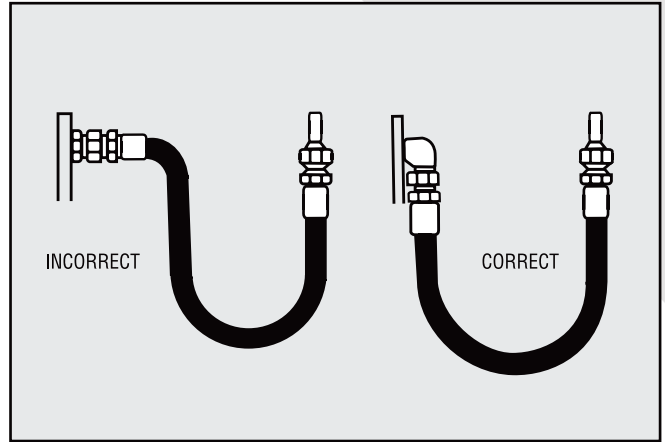
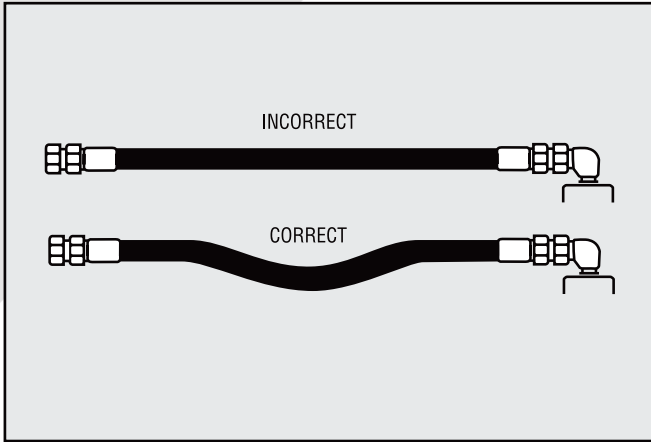

TWIST ANGLE CHART

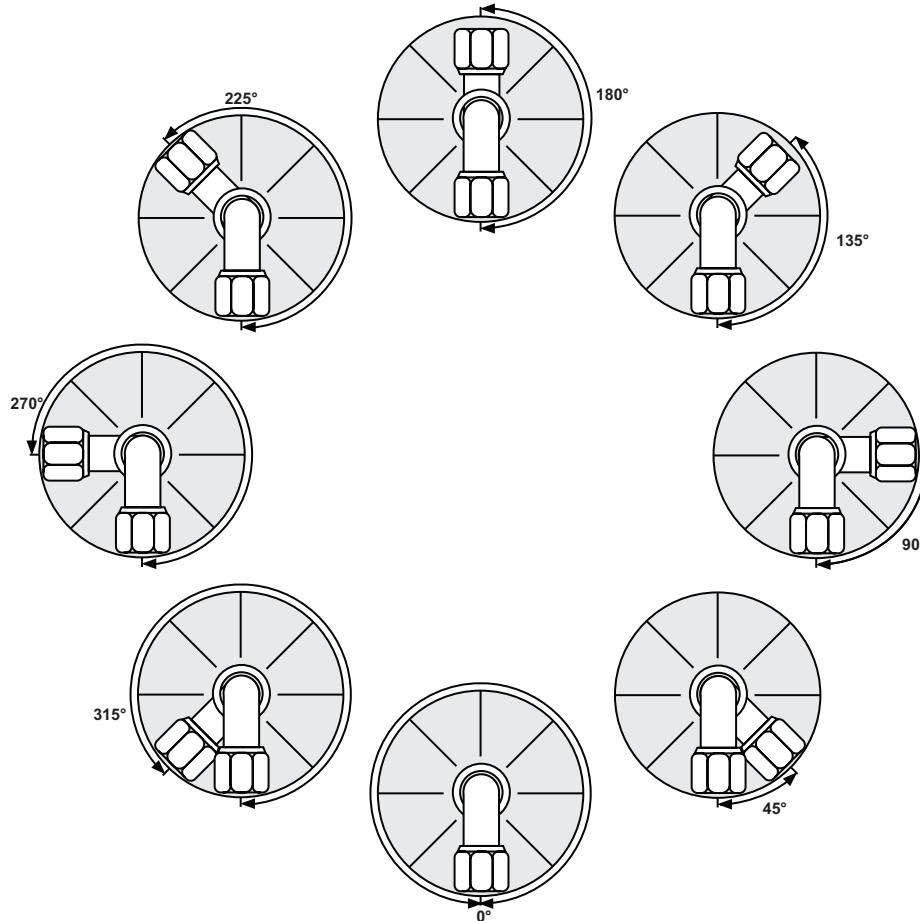

**Angle of Rotation: (measured in degrees)
Measure the angle counter clockwise**

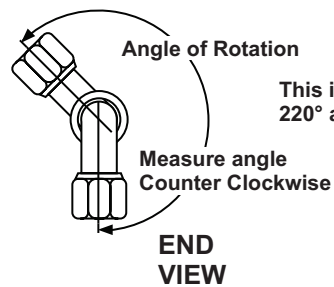

This is an example of a
220° angle of rotation.

THREAD IDENTIFICATION

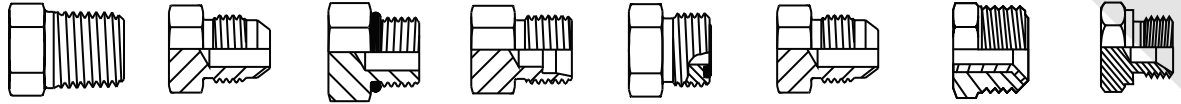

INCH SIZE	DASH SIZE	NPTF PIPE	SAE 37° Flare / JIC	SAE O-RING BOSS	ERMETO Flareless	ORFS FOR-SEAL	SAE 45° Flare / J512	INVERTED Flare / J512	BSP British
1/8	-02	1/8 - 27	5/16 - 24	5/16 - 24	5/16 - 24	--	5/16 - 24	5/16 - 28	1/8 - 28
3/16	-03	--	3/8 - 24	3/8 - 24	3/8 - 24	--	3/8 - 24	3/8 - 24	--
1/4	-04	1/4 - 18	7/16 - 20	7/16 - 20	7/16 - 20	9/16 - 18	7/16 - 20	7/16 - 24	1/4 - 19
5/16	-05	--	1/2 - 20	1/2 - 20	1/2 - 20	--	1/2 - 20	1/2 - 20	--
3/8	-06	3/8 - 18	9/16 - 18	9/16 - 18	9/16 - 18	11/16 - 16	5/8 - 18	5/8 - 18	3/8 - 19
7/16	-07	--	--	--	--	--	11/16-16	11/16 - 18	--
1/2	-08	1/2 - 14	3/4 - 16	3/4 - 16	3/4 - 16	13/16 - 16	3/4 - 16	3/4 - 18	1/2 - 14
5/8	-10	--	7/8 - 14	7/8 - 14	7/8 - 14	1 - 14	7/8 - 14	7/8 - 18	5/8 - 14
3/4	-12	3/4 - 14	1.1/16 - 12	1.1/16 - 12	1.1/16 - 12	1.3/16 - 12	1.1/16 - 14	1.1/16 - 16	3/4 - 14
7/8	-14	--	1.3/16 - 12	1.3/16 - 12	1.3/16 - 12	--	1.1/4 - 12	1.3/16 - 16	--
1	-16	1 - 11.5	1.5/16 - 12	1.5/16 - 12	1.5/16 - 12	1.7/16 - 12	1.3/8 - 12	1.5/16 - 16	1 - 11
1.1/4	-20	1.1/4 - 11.5	1.5/8 - 12	1.5/8 - 12	1.5/8 - 12	1.11/16 - 12	--	--	1.1/4 - 11
1.1/2	-24	1.1/2 - 11.5	1.7/8 - 12	1.7/8 - 12	1.7/8 - 12	2 - 12	--	--	1.1/2 - 11
2	-32	2 - 11.5	2.1/2 - 12	2.1/2 - 12	2.1/2 - 12	--	--	--	2 - 11
2.1/2	-40	2.1/2 - 8	3 - 12	--	--	--	--	--	2.1/2 - 11
3	-48	3 - 8	3.1/2 - 12	--	--	--	--	--	3 - 11

SÉRIE MÉTRIQUE / METRIC SERIES

LL		L		S		Français French	
Allemand Extra Leger	/ German Super Light	Allemand Legere	/ German Light	Allemand Lourd	/ German Heavy		
TUBE	Filetage Thread	TUBE	Filetage Thread	TUBE	Filetage Thread	TUBE	Filetage Thread
4 MM	M 8 X 1.0	6 MM	M 12 X 1.5	6 MM	M 14 X 1.5	12.00 MM	M 18 X 1.5
5 MM	M 10 X 1.0	8 MM	M 14 X 1.5	8 MM	M 16 X 1.5	13.25 MM	M 20 X 1.5
6 MM	M 10 X 1.0	10 MM	M 16 X 1.5	10 MM	M 18 X 1.5	16.75 MM	M 24 X 1.5
8 MM	M 12 X 1.0	12 MM	M 18 X 1.5	12 MM	M 20 X 1.5	21.25 MM	M 30 X 1.5
10 MM	M 14 X 1.0	15 MM	M 22 X 1.5	14 MM	M 22 X 1.5	26.75 MM	M 36 X 1.5
12 MM	M 16 X 1.0	18 MM	M 26 X 1.5	16 MM	M 24 X 1.5	33.50 MM	M 45 X 1.5
		22 MM	M 30 X 2.0	20 MM	M 30 X 2.0		
		28 MM	M 36 X 2.0	25 MM	M 36 X 2.0		
		35 MM	M 45 X 2.0	30 MM	M 42 X 2.0		
		42 MM	M 52 X 2.0	38 MM	M 52 X 2.0		

HOSE TYPE	INTERIOR HOSE DIAMETER											
	1/8"	3/16"	1/4"	5/16"	3/8"	1/2"	5/8"	3/4"	1"	1.1/4"	1.1/2"	2"
SNF1 100R1AT/SN	—	3,625	3,263	—	2,610	2,320	—	1,523	1,276	914	725	580
SNF17 100R17	—	—	3,040	—	3,040	3,040	—	3,040	3,040	—	—	—
SNF2 100R2AT/SN	—	—	5,800	5,074	4,785	3,988	3,625	3,118	2,393	1,813	1,305	1,131
SNF2SC EN857 TYPE 2SC	—	—	5,800	—	4,785	3,988	3,625	—	—	—	—	—
TECH2SNK 100R16S	—	—	6,530	—	5,590	5,010	4,640	4,350	3,270	2,540	—	—
NFJACK EN857 TYPE 2SC	—	—	10,000	—	10,000	—	—	—	—	—	—	—
NFFS(FIRE SUPPRESSION) 100R1AT/1SN	—	—	3,263	—	2,610	2,320	—	1,523	1,276	—	—	—
NFPILOT ISO 1307	—	1,740	1,740	1,740	1,740	1,740	—	—	—	—	—	—
PUSHRC RUBBER COVER	—	—	250	250	250	250	250	250	—	—	—	—
PUSHCC COTTON COVER	—	—	300	300	300	300	300	300	—	—	—	—
N4 100R4	—	—	—	—	—	—	—	300	250	200	150	100
HORIZON GENERAL PURPOSE	—	—	250	—	250	250	250	250	200	200	150	150
TECH12 100R12	—	—	—	—	4,003	4,003	4,003	4,003	4,003	3,002	2,495	2,495
TECH13 100R13	—	—	—	—	—	—	—	5,004	5,004	5,004	5,004	5,004
TECH15 100R15	—	—	—	—	6,019	6,019	—	6,019	6,019	6,019	6,019	6,019
NF5 NUVOFLEX 5000	—	—	—	—	5,070	5,070	5,070	5,070	5,070	5,070	5,000	5,000
NF6 NUVOFLEX 6000	—	—	—	—	6,090	6,090	6,090	6,090	6,090	6,090	6,090	6,090
NF4SH 4SH	—	—	—	—	—	—	—	—	—	—	4,205	3,625
NFPW1 100R1SN	—	—	4,000	—	4,000	4,000	—	—	—	—	—	—
NFPW2 100R2SN	—	—	—	—	5,800	—	—	—	—	—	—	—
R6 100R6	—	500	400	400	400	400	350	300	—	—	—	—
TEFLON 100R14	3,260	2,750	2,610	2,540	2,390	1,740	1,270	1,010	870	—	—	—
N5 100R5	—	3,045	3,045	2,277	—	1,770	1,523	—	—	—	—	—
NFR7 100R7	3,000	3,000	2,750	2,500	2,250	2,000	—	1,250	—	—	—	—
NFR8 100R8	5,000	5,000	5,000	—	4,000	3,500	—	2,250	2,000	—	—	—
NFR18 100R18	—	—	3,000	—	3,000	3,000	—	—	—	—	—	—
GAUNTLET 100R1SN	—	—	—	—	3,000	3,000	—	—	—	—	—	—
J20R3 AUTO HEATER	—	—	—	—	—	60	60	50	50	—	—	—
J30R7 FUEL LINE	50	50	50	50	50	35	35	35	—	—	—	—

*ALL PRESSURE ARE LISTED IN POUNDS PER INCH (PSI)
 *NEVER USE ANY HYDRAULIC HOSE OR THREADS UP TO IT'S RATED PRESSURE
 *ALWAYS ALLOW EXTRA SAFETY MARGIN TO ALLOW FOR SPIKE.

THREAD TYPE	STANDARD THREAD SIZE											
	-2(1/8)	-3(3/16)	-4(1/4)	-5(5/16)	-6(3/8)	-8(1/2)	-10(5/8)	-12(3/4)	-16(1)	-20(1.1/4)	-24(1.1/2)	-32(2)
M.NPT	11,000	—	11,000	—	10,000	10,000	—	10,000	7,200	5,100	5,100	3,100
F.NPT FIX	11,000	—	10,000	5,000	5,000	4,500	3,500	3,500	3,000	2,500	2,000	1,500
F.NPT SWIVEL	10,000	—	10,000	—	10,000	8,000	—	6,500	5,100	4,100	4,100	3,100
M.JIC	5,000	5,000	5,000	5,000	5,000	4,500	3,500	3,500	3,000	2,500	2,000	1,500
F.JIC SWIVEL	5,000	5,000	4,500	4,000	4,000	4,000	3,000	3,000	2,500	2,000	1,500	1,125
ORB	5,000	5,000	5,000	5,000	5,000	4,500	3,500	3,500	3,000	2,500	2,000	1,500
BSP BOUNDED SEAL	6,100	—	6,100	—	6,100	5,100	5,100	4,100	4,100	4,100	3,100	2,100
BSP ED SEAL	9,000	—	9,000	—	7,000	7,000	7,000	7,000	5,300	4,100	4,100	3,300
F.BSP SWIVEL	10,000	—	10,000	—	10,000	10,000	10,000	9,000	9,000	7,000	6,100	5,100
ORFS	—	—	10,000	—	10,000	9,150	9,150	7,000	6,100	4,100	4,100	—
FLANGE CODE 61	—	—	—	—	—	5,000	—	5,000	5,000	4,000	3,000	3,000
FLANGE CODE 62	—	—	—	—	—	6,000	—	6,000	6,000	6,000	6,000	6,000
FLANGE SUPER CAT	—	—	—	—	—	—	—	6,000	6,000	6,000	6,000	6,000

THREAD TYPE	METRIC THREAD SIZE											
	M14X1.5	M16X1.5	M18X1.5	M22X1.5	M24X1.5	M27X2.0	M30X1.5	M33X1.5	M36X1.5	M42X1.5	M50X2.0	M60X2.0
KOMATSU	6,100	6,100	6,100	5,500	5,100	4,100	4,100	3,100	2,500	2,500	1,500	1,000

TUBE TYPE	METRIC TUBE SIZE (mm)															
	6mm	8mm	10mm	12mm	14mm	15mm	16mm	18mm	20mm	22mm	25mm	28mm	30mm	35mm	38mm	42mm
METRIC LIGHT	6,300	6,300	6,300	5,100	—	5,100	—	5,100	—	4,100	—	3,100	—	2,600	—	2,600
METRIC HEAVY	10,000	10,000	10,000	9,000	9,000	—	6,100	—	6,100	—	6,100	—	6,100	—	6,100	—

*ALL PRESSURE ARE LISTED IN POUNDS PER INCH (PSI)
 *NEVER USE ANY HYDRAULIC HOSE OR THREADS UP TO IT'S RATED PRESSURE
 *ALWAYS ALLOW EXTRA SAFETY MARGIN TO ALLOW FOR SPIKE.

PRESSURE CONVERSION TABLE			
PSI	KPA	MPA	BAR
100	689.0	0.70	6.9
200	1,379.0	1.40	13.8
300	2,068.0	2.10	20.7
400	2,758.0	2.80	27.6
500	3,447.0	3.40	34.5
600	4,137.0	4.10	41.4
700	4,826.0	4.80	48.3
800	5,516.0	5.50	55.2
900	6,205.0	6.20	62.1
1,000	6,895.0	6.90	68.9
2,000	13,790.0	13.80	137.9
3,000	20,684.0	20.70	206.8
4,000	27,579.0	27.60	275.8
5,000	34,474.0	34.50	344.7
6,000	41,369.0	41.40	413.7
7,000	48,263.0	48.30	482.6
8,000	55,158.0	55.20	551.6
9,000	62,053.0	62.10	620.5
10,000	68,948.0	68.90	689.0

How to Measure Assemblies

Use to identify length of customer sample and for checking proper length of new hose assembly.

Unless otherwise specified, assembly length shall be the overall length measured from the extreme end of one connector to the extreme end of the other. Where elbow connectors used, measurement shall be to the centerline of the sealing surface of the elbow end. See figures below

Hold the assembly so that you can look along the length of the hose and with the fitting furthest away from you in the vertical position. Measure the angle between the vertical fitting and the one nearest to you in a clockwise direction. Relationship can then be expressed from 0° to 360°.

Method of measurement should be specified. Tolerances on assembly length shall be as in table below.

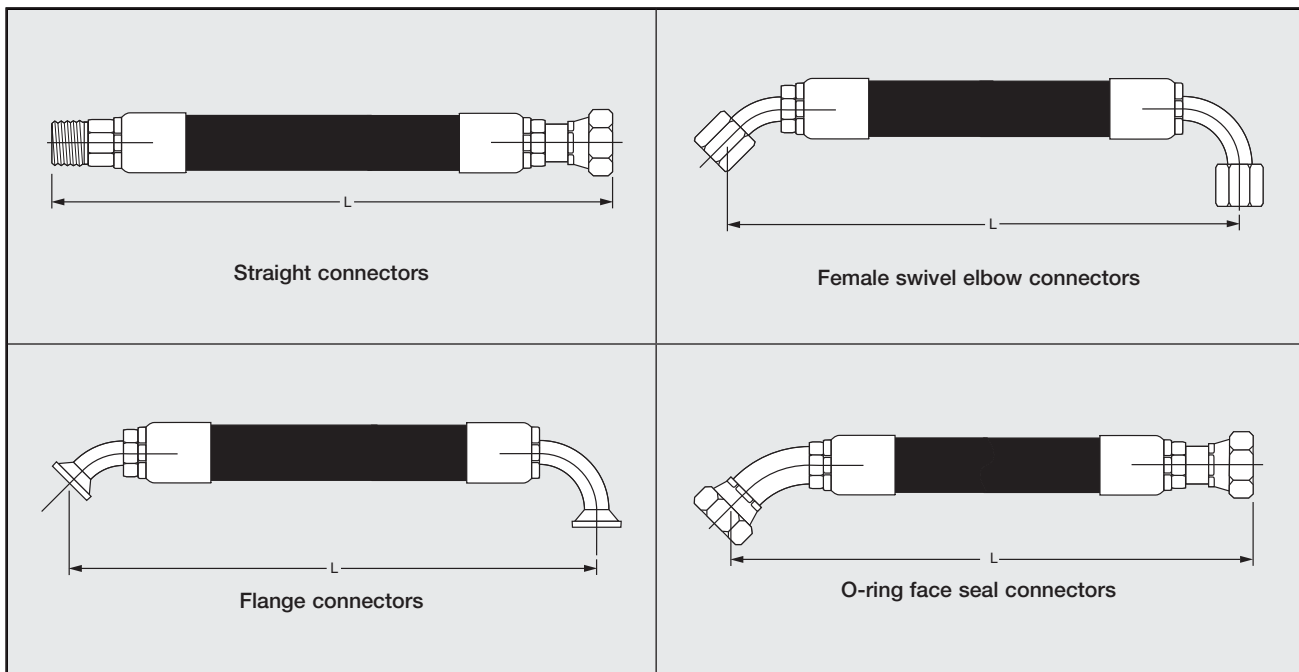

Assembly Length	Tolerances (decimal inch)	Tolerances (fraction inch)	Tolerances (mm)
Up through 12" (304.8 mm)	0.13	1/8	3.2
Over 12" through 18" (304.8 through 457.2 mm)	0.19	3/16	4.8
Over 18" through 36" (457.2 through 914.4 mm)	0.25	1/4	6.4
Over 36" (914.4 mm)	1%	1%	1%

Angular Relationships

Hold the assembly so that you can look along the length of the hose and with the fitting furthest away from you in the vertical position. Measure the angle between the vertical fitting and the one nearest to you in a clockwise direction. Relationship can then be expressed from 0° to 360°.

END-THREAD MEASUREMENT CHART

Pour déterminer un Filet. veuillez prendre le diamètre extérieur du filetage Male (D) ou le diamètre intérieur du filetage Femelle (d). Ensuite. faire correspondre avec la mesure obtenue sous la colonne MM; ceci va déterminer le filet voulu.

To identify thread size. measure the exterior Male thread diameter (D) or the internal Female thread diameter (d), then match with the corresponding measurement in Column MM; this will give you the correspondent thread size.

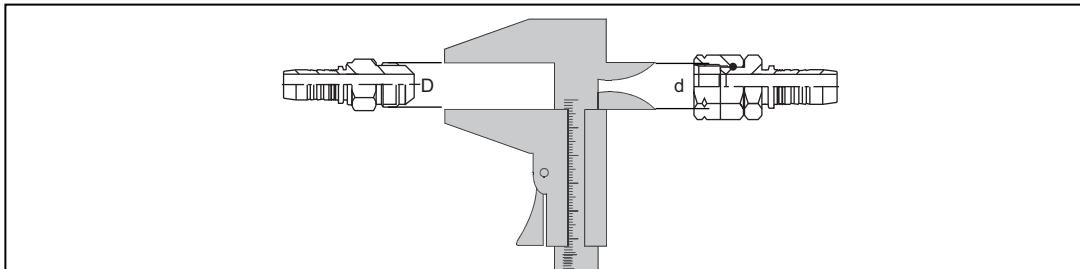

MALE O.D.	MM	FEMALE I.D.
	8.5	3/8"-24 UNF
	8.7	1/8"-28 GAS
	9.2	1/8"-27 NPSM
3/8"-24 UNF	9.4	
1/8"-28 GAS	9.6	
M10X1	10.0	7/16"-20 UNF
1/8"-27 UNF	10.4	
	10.5	M12X1.5
7/16"-20 UNF	11.0	
	11.4	1/2"-20 UNF
	11.6	1/4"-19 GAS
M12X1.5	12.0	
	12.2	1/4"-18 NPSM
1/2"-20 UNF	12.5	M14X1.5
1/4"-19 GAS	13.0	9/16"-18 UNF
1/4"-18 NPTF	13.9	
M14X1.5	14.0	
9/16"-18 UNF	14.2	
	14.5	M16X.15
	14.6	5/8"-18 UNF
	15.1	3/8"-19 GAS
	15.5	3/8"-18 NPSM
5/8"-18 UNF	15.7	
M16X1.5	16.0	11/16"-16 UN
	16.5	M18X1.5
3/8"-19 GAS	16.6	
3/8"-18 NPTF	17.3	
11/16"-16 UN	17.4	3/4"-16 UNF
M18X1.5	18.0	
	18.5	M20X1.5
	18.8	1/2"-14 GAS
3/4"-16 UNF	19.0	13/16"-16 UN

MALE O.D.	MM	FEMALE I.D.
	19.2	1/2"-14 NPSM
M20x1.5	20.0	
	20.3	7/8"-14 UNF
13/16"-16 UN	20.5	M22x1.5
1/2"-14 GAS	20.8	
	21.1	5/8"-14 GAS
1/2"-14 NPTF	21.6	
M22x1.5	22.0	
7/8"-14 UNF	22.2	
	22.5	M24x1.5
5/8"-14 GAS	22.8	
	23.8	1"-14 UNS
M24x1.5	24.0	
	24.5	M26x1.5
	24.6	3/4"-14 GAS-NPSM
	24.9	1.1/16"-12 UN
	25.0	M27x2
1"-14 UNS	25.3	
M26x1.5	26.0	
3/4"-14 GAS	26.3	
1.1/16"-12 UN	26.7	
3/4"-14 NPTF	26.9	
M27x2	27.0	
	27.9	1.3/16"-12 UN
	28.0	M30x2
M30x2	30.0	
1.3/16"-12 UN	30.1	
	30.7	1"-11.5 NPSM
	30.9	1"-11 GAS
	31.0	M33x2
	31.2	1.5/16"-12 UN
M33x2	33.0	

MALE O.D.	MM	FEMALE I.D.
1"-11 GAS	33.2	
1.5/16"-12 UN	33.3	
1"-11.5" NPTF	33.8	
	34.0	M36X2
M36X2	36.0	
	39.1	1.5/8"-12 UN
	39.4	1.1/4"-11.5 NPSM
	39.5	1.1/4"-11 GAS
	40.0	M42X2
1.5/8"-12 UN	41.1	
1.1/4"-11 GAS	41.7	
M42X2	42.0	
1.1/4"-11.5 NPTF	42.4	
	43.0	M45X2
M45X2	45.0	
	45.2	1.1/2"-11 GAS
	45.5	1.1/2"-11.5 NPSM
	45.7	1.7/8"-12 UN
	46.0	M48X2
1.7/8"-12 UN	47.5	
1.1/2"-11 GAS	47.7	
M48x2	48.0	
1.1/2"-11.5 NPTF	48.5	
	48.8	2"-12 UN
	50.0	M52x2
2"-12 UN	50.7	
M52x2	52.0	
	57.0	2"-11 GAS
2"-11 GAS	59.4	
2"-11.5 NPTF	60.6	
	61.2	2.1/2"-12 UN
2.1/2"-12 UN	63.3	

NUVOFLEX

No. de Pièces Part No.	Description	Page(s)
N4	SAE 100R4	20
N5	SAE J517 100R5	17
N5HT	SAE J517 100R5 HIGH TEMPERATURE	16
NF2HT	SAE100R2AT/2SN HIGH TEMPERATURE	16
NF4SH	4SH	22
NF5	ISO 5000 PSI	23
NF6	ISO 6000 PSI	23
NFFS	SAE100R1AT/1SN FIRE SUPPRESSION	17
NFJACK	SAE100R2AT/2SN - 10000 PSI	18
NFPILOT	PILOT ISO 1307	18
NFPW1	PRESSURE WASHER 1AT	29
NFPW2	PRESSURE WASHER 2AT	29
NFR18	SAE100R18	28
NFR18T	SAE100R18 TWIN	28
NFR7	SAE100R7	24
NFR7NC	SAE100R7 NON-CONDUCTIVE	26
NFR7T	SAE100R7 TWIN	25
NFR7TNC	SAE100R7 TWIN NON-CONDUCTIVE	27
NFR8	SAE100R8	24
NFR8NC	SAE100R8 NON-CONDUCTIVE	26
NFR8T	SAE100R8 TWIN	25
NFR8TNC	SAE100R8 TWIN NON-CONDUCTIVE	27
SNF1	SMOOTH COVER SAE100R1AT/1SN	13
SNF17	SMOOTH COVER SAE100R17	13
SNF2	SMOOTH COVER SAE100R2AT/2SN	14
SNF2SC	SMOOTH COVER EN857 TYPE 2SC	14

TECH HOSE

No. de Pièces Part No.	Description	Page(s)
TECH12	TECH SAE100R12	21
TECH13	TECH SAE100R13	21
TECH15	TECH SAE100R15	22
TECH2SNK	TECH SAE100R16S	15

OTHERS

No. de Pièces Part No.	Description	Page(s)
BRAKE	AIR BRAKE HOSE	32
GAUN	GAUNTLET CLEANING EQUIPMENT HOSE FOR FOOD PLAN	30
HORIZON	GENERAL PURPOSE	30
J20R3	AUTO HEATER HOSE	32
J30R7	FUEL LINE / PVC / EMISSION	31
PUSHCC	PUSH-ON COTTON COVER	19
PUSHRC	PUSH-ON RUBBER COVER	19
R6	FUEL LINE	31
TEF	POLYTETRAFLUOROETHYLENE (PTFE) 100R14	20

also available...



STAINLESS STEEL

BRASS

**ADAPTERS
=1200 SKU'S**

- 1/8-2" range sizes in most combinations.
- 316SS
- 100 different combinations.
- NPT
- JIC
- ORB
- BSP
- ORFS

**HOSE FITTINGS
=300 SKU'S**

- 1/4-2" range sizes in most combinations
- 316SS
- 30 different combinations
- NPT
- JIC
- ORB
- BSP
- ORFS
- DIN LAND S
- FLANGE C61/C62

**BALL VALVES &
QUICK COUPLERS**

Ball Valves

- 1/4-1"
- HIGH PRESSURE
- NPT
- 2 WAY
- 3 WAY

Quick Couplers

- 1/4-1"
- NPT
- ISO 16028 (FLAT FACE)
- ISO B
- ISO A

**BRASS
COMPONENTS**

- Adapters
- Fittings
- Ball Valve
- Quick Couplers
- DOT Push-To-Connect
- DOT AIR Brake



BOYAUX HYDRAULIQUES ET INDUSTRIEL
HYRAULIC AND INDUSTRIAL HOSE
2020



SNF1

SAE100R1AT/1SN

TUBE: MINERAL, VEGETABLE AND HYDRAULIC OIL RESISTANT SPECIAL SYNTHETIC RUBBER.
REINFORCEMENT: 1 HIGH TENSILE STEEL WIRE BRAID
COVER: OIL, ABRASION AND WEATHER RESISTANT SPECIAL SYNTHETIC RUBBER.
APPLICATION: FOR LOW-MEDIUM PRESSURE HYDRAULIC SYSTEMS IN INDUSTRY AND AGRICULTURE.

TUBE: CAOUTCHOUC SYNTHÉTIQUE SPÉCIAL RÉSISTANT AUX HUILES HYDRAULIQUES, MINÉRALES ET LUBRIFIANTS.
REINFORCEMENT: 1 TRESSE D'ACIER TRÈS RÉSISTANTE.
REVÊTEMENT: CAOUTCHOUC SYNTHÉTIQUE SPÉCIAL. RÉSISTANT A L'ABRASION, AUX HUILES ET CARBURANTS.
APPLICATION: POUR LES SYSTÈMES HYDRAULIQUES A BASSE ET MOYENNE PRESSION DANS L'INDUSTRIE ET L'AGRICULTURE.



HOSE SIZE I.D.			ROD O.D.	HOSE O.D.	Working Pressure		Burst Pressure		Min. Bend Radius	Weight	Compatible Fittings		
SIZE	Inch.	mm	mm	mm	BAR	PSI	BAR	PSI	mm	lbs/ft			
SNF1-03	3/16"	4.8	9.6	11.6	250	3625	1000	14500	90	0.12	A	ST34	—
SNF1-04	1/4"	6.4	11.1	13.2	225	3263	900	13050	100	0.15	A	ST34	R310
SNF1-06	3/8"	9.5	15.0	17.2	180	2610	720	10440	130	0.23	A	ST34	R310
SNF1-08	1/2"	12.7	18.1	20.4	160	2320	640	9280	180	0.28	A	ST34	R310
SNF1-12	3/4"	19.0	25.2	27.5	105	1523	420	6090	240	0.40	A	ST34	R310
SNF1-16	1"	25.4	33.1	35.4	88	1276	350	5075	300	0.59	A	ST34	R310
NF1-20	1-1/4"	31.8	40.2	43.5	63	914	250	3625	420	0.81	A	ST34	—
NF1-24	1-1/2"	38.1	46.7	50.0	50	725	200	2900	500	0.94	A	ST34	—
NF1-32	2"	50.8	60.2	63.6	40	580	160	2320	630	1.28	A	ST34	—

-40°C / + 100°C (+125°C DISCONTINUOUS) | -40°F / + 212°F (+257°F DISCONTINUOUS)
 FLAME RESISTANCE: (U.S. MSHA CERTIFICATION)

SNF17

SAE100R17

TUBE: MINERAL, VEGETABLE AND HYDRAULIC OIL RESISTANT SPECIAL SYNTHETIC RUBBER.
REINFORCEMENT: 1 HIGH TENSILE STEEL WIRE BRAID FROM (1/4" TO 1/2").
 2 WIRE (3/4" TO 1")
COVER: OIL, ABRASION AND WEATHER RESISTANT SPECIAL SYNTHETIC RUBBER.
APPLICATION: FOR LOW-MEDIUM PRESSURE HYDRAULIC SYSTEMS IN INDUSTRY AN AGRICULTURE.

TUBE: CAOUTCHOUC SYNTHÉTIQUE SPÉCIAL RÉSISTANT AUX HUILES HYDRAULIQUES, MINÉRALES ET LUBRIFIANTS.
REINFORCEMENT: 1 TRESSE D'ACIER TRÈS RÉSISTANTE DE (1/4" À 1/2").
 2 TRESSES (3/4" À 1")
REVÊTEMENT: CAOUTCHOUC SYNTHÉTIQUE SPÉCIAL. RÉSISTANT A L'ABRASION, AUX HUILES, CARBURANTS.
APPLICATION: POUR LES SYSTÈMES HYDRAULIQUES A BASSE ET MOYENNE PRESSION DANS L'INDUSTRIE ET L'AGRICULTURE.



HOSE SIZE I.D.			ROD O.D.	HOSE O.D.	Working Pressure		Burst Pressure		Min. Bend Radius	Weight	Compatible Fittings		
SIZE	Inch.	mm	mm	mm	BAR	PSI	BAR	PSI	mm	lbs/ft			
SNF17-04	1/4"	6	10.4	12.2	210	3040	840	12180	50	0.12	A	ST82	—
SNF17-06	3/8"	10	13.6	15.5	210	3040	840	12180	65	0.20	A	ST34	—
SNF17-08	1/2"	12	16.8	19.0	210	3040	840	12180	90	0.28	A	ST34	—
SNF17-12	3/4"	19	25.6	27.7	210	3040	840	12180	120	0.55	A	ST34	—
SNF17-16	1"	25	33.3	35.4	210	3040	840	12180	150	0.83	A	ST34	—

-40°C / + 100°C (+125°C DISCONTINUOUS) | -40°F / + 212°F (+257°F DISCONTINUOUS)
 FLAME RESISTANCE: (U.S. MSHA CERTIFICATION)

TUBE: MINERAL, VEGETABLE AND HYDRAULIC OIL RESISTANT SPECIAL SYNTHETIC RUBBER.
REINFORCEMENT: 2 HIGH TENSILE STEEL WIRE BRAID
COVER: OIL, ABRASION AND WEATHER RESISTANT SPECIAL SYNTHETIC RUBBER.
APPLICATION: FOR LOW-MEDIUM PRESSURE HYDRAULIC SYSTEMS IN INDUSTRY AND AGRICULTURE.

TUBE: CAOUTCHOUC SYNTHÉTIQUE SPÉCIAL RÉSIDANT AUX HUILES HYDRAULIQUES, MINÉRALES ET LUBRIFIANTS.
REINFORCEMENT: 2 TRESSSES D'ACIER TRÈS RÉSIDANTES.
REVÊTEMENT: CAOUTCHOUC SYNTHÉTIQUE SPÉCIAL. RÉSIDANT A L'ABRASION, AUX HUILES ET CARBURANTS.
APPLICATION: POUR LES SYSTÈMES HYDRAULIQUES A BASSE ET MOYENNE PRESSION DANS L'INDUSTRIE ET L'AGRICULTURE.



HOSE SIZE I.D.			ROD O.D.	HOSE O.D.	Max. Working Pressure		Min. Burst Pressure		Min. Bend Radius	Weight	Compatible Fittings		
SIZE	Inch.	mm	mm	mm	BAR	PSI	BAR	PSI	mm	lbs/ft			
SNF2-04	1/4"	6.4	12.8	15.0	400	5800	1600	23200	100	0.26	A	ST34	R320
SNF2-05	5/16"	8.0	14.3	16.5	350	5075	1400	20300	115	0.29	A	ST34	—
SNF2-06	3/8"	9.5	16.7	18.9	330	4785	1320	19140	130	0.37	A+B	ST34	R320
SNF2-08	1/2"	12.7	19.8	22.2	275	3988	1100	15950	180	0.43	A+B	ST34	R320
SNF2-10	5/8"	16.0	22.9	25.2	250	3625	1000	14500	200	0.50	A+B	ST34	R320
SNF2-12	3/4"	19.0	26.9	29.2	215	3118	850	12325	240	0.62	A+B	ST34	R320
SNF2-16	1"	25.4	34.8	37.2	165	2393	650	9425	300	0.87	A+B	ST34	R320
NF2-20	1-1/4"	31.8	44.3	47.3	125	1813	500	7250	420	1.27	A	ST34	—
NF2-24	1-1/2"	38.1	50.7	53.7	90	1305	360	5220	500	1.42	A	ST34	—
NF2-32	2"	50.8	63.5	66.7	78	1131	310	4500	630	1.86	A	ST34	—

-40°C / + 100°C (+125°C DISCONTINUOUS) | -40°F / + 212°F (+257°F DISCONTINUOUS)
 FLAME RESISTANCE: (U.S. MSHA CERTIFICATION)

SNF2SC

EN857 TYPE 2SC (Exceeds SAE100R16)

TUBE: MINERAL, VEGETABLE AND HYDRAULIC OIL RESISTANT SPECIAL SYNTHETIC RUBBER.
REINFORCEMENT: 2 HIGH TENSILE STEEL WIRE BRAID
COVER: OIL, ABRASION AND WEATHER RESISTANT SPECIAL SYNTHETIC RUBBER.
APPLICATION: FOR MEDIUM-HIGH PRESSURE HYDRAULIC SYSTEMS USING HYDRAULIC OILS, MINERAL AND VEGETABLE LUBRICANTS.

TUBE: CAOUTCHOUC SYNTHÉTIQUE SPÉCIAL RÉSIDANT AUX HUILES HYDRAULIQUES, MINÉRALES ET LUBRIFIANTS.
REINFORCEMENT: 2 TRESSSES D'ACIER TRÈS RÉSIDANTES.
REVÊTEMENT: CAOUTCHOUC SYNTHÉTIQUE SPÉCIAL. RÉSIDANT A L'ABRASION, AUX HUILES, CARBURANTS ET DÉTERGENTS.
APPLICATION: POUR LES SYSTÈMES HYDRAULIQUES A MOYENNE ET HAUTE PRESSION, UTILISANT DES HUILES HYDRAULIQUES VÉGÉTALES ET MINÉRALES.



HOSE SIZE I.D.			ROD O.D.	HOSE O.D.	Working Pressure		Burst Pressure		Min. Bend Radius	Weight	Compatible Fittings		
SIZE	Inch.	mm	mm	mm	BAR	PSI	BAR	PSI	mm	lbs/ft			
SNF2SC-04	1/4"	6.4	11.3	13.4	400	5800	1600	23200	75	0.19	A	ST34	—
SNF2SC-06	3/8"	9.5	15.0	17.1	330	4785	1320	19140	90	0.28	A	ST34	—
SNF2SC-08	1/2"	12.7	18.6	20.7	275	3988	1100	15950	130	0.39	A	ST34	—
SNF2SC-10	5/8"	16.0	21.7	23.8	250	3625	1000	14500	170	0.46	A	ST34	—

-40°C / + 100°C (+125°C DISCONTINUOUS) | -40°F / + 212°F (+257°F DISCONTINUOUS)
 FLAME RESISTANCE: (U.S. MSHA CERTIFICATION)

TUBE: OIL RESISTANT SYNTHETIC RUBBER.
REINFORCEMENT: TWO BRAIDS OF HIGH TENSILE STEEL WIRE.
COVER: OIL AND WEATHER RESISTANT BLACK SYNTHETIC RUBBER. SMOOTH COVER
APPLICATION: HIGH PRESSURE HYDRAULIC LINES
 : TOUGH COVER

TUBE: CAOUTCHOUC SYNTHÉTIQUE RÉSIDANT À L'HUILE.
REINFORCEMENT: DEUX TRESSÉS DE FIL D'ACIER À HAUTE RÉSIDANCE.
REVÊTEMENT: CAOUTCHOUC SYNTHÉTIQUE NOIR RÉSIDANT AUX INTEMPÉRIES.
APPLICATION: LES CONDUITES HYDRAULIQUES À HAUTE PRESSION.



HOSE SIZE I.D.			HOSE O.D.	Working Pressure		Burst Pressure		Min. Bend Radius	Weight	Compatible Fittings		
SIZE	Inch.	mm		BAR	PSI	BAR	PSI			mm	lbs/ft	
TECH2SNK-04	1/4"	6.4	13.1	450	6530	1800	26107	45	0.18	A	ST34	—
TECH2SNK-06	3/8"	9.5	17.1	385	5590	1540	22336	65	0.26	A	ST34	—
TECH2SNK-08	1/2"	12.5	20.3	345	5010	1380	20015	80	0.36	A	ST34	—
TECH2SNK-10	5/8"	15.8	24.7	320	4640	1280	18565	90	0.48	A	ST34	—
TECH2SNK-12	3/4"	19.0	27.7	300	4350	1200	17405	120	0.58	A	ST34	—
TECH2SNK-16	1"	25.4	35.8	225	3270	900	13053	160	0.88	A	ST34	—
TECH2SNK-20	1-1/4"	31.8	43.5	175	2540	700	10153	300	1.14	*	ST34	—

HYDRAULICS OILS: FROM -40°C TO 100°C (FROM -40°F TO 212°F)
WATER GLYCOL HYDRAULIC FLUIDS: FROM -40°C TO 70°C (FROM -40°F TO 158°F)
WATER: FROM 0°C TO 70°C (FROM 32°F TO 158°F)
AIR: UP TO 70°C (UP TO 158°F)

NF2HT

SAE100R2AT/DIN - EN 853 2SN

TUBE: HIGH TEMPERATURE HYDRAULIC OIL RESISTANT SPECIAL SYNTHETIC RUBER.
REINFORCEMENT: 2 HIGH TENSILE STEEL WIRE BRAID
COVER: OIL, ABRASION AND WEATHER RESISTANT SPECIAL SYNTHETIC RUBBER.
APPLICATION: FOR MEDIUM-HIGH PRESSURE HYDRAULIC SYSTEMS IN INDUSTRY. COMPRESSORS AND MINING WHERE OPERATING TEMPERATURE ARE UP TO 150°C.

TUBE: CAOUTCHOUC SYNTHÉTIQUE SPÉCIAL RÉSISTANT AUX HUILES HYDRAULIQUES A HAUTE TEMPERATURE.
REINFORCEMENT: 2 TRESSERES D'ACIER TRÈS RÉSISTANTES.
REVÊTEMENT: CAOUTCHOUC SYNTHÉTIQUE SPÉCIAL. RÉSISTANT A L'ABRASION, AUX HUILES ET CARBURANTS.
APPLICATION: POUR LES SYSTÈMES HYDRAULIQUES A MOYENNE ET HAUTE PRESSION DANS L'INDUSTRIE. COMPRESSEURS. L'EXPLOITATION MINIÈRE OU ON EXIGE UNE TEMPÉRATURE JUSQU'A 150°C.



HOSE SIZE I.D.			ROD O.D.	HOSE O.D.	Max. Working Pressure		Min. Burst Pressure		Min. Bend Radius	Weight	Compatible Fittings		
SIZE	Inch.	mm	mm	mm	BAR	PSI	BAR	PSI	mm	lbs/ft			
NF2HT-04	1/4"	6.4	12.8	15.0	400	5800	1600	23200	100	0.26	A	ST34/STSK92	—
NF2HT-06	3/8"	9.5	16.7	18.9	330	4785	1320	19140	130	0.37	A	ST34/STSK92	—
NF2HT-08	1/2"	12.7	19.8	22.2	275	3988	1100	15950	180	0.43	A	ST34/STSK92	—
NF2HT-10	5/8"	16.0	22.9	25.2	250	3625	1000	14500	200	0.50	A	ST34/STSK92	—
NF2HT-12	3/4"	19.0	26.9	29.2	215	3118	850	12325	240	0.62	A	ST34/STSK92	—
NF2HT-16	1"	25.4	34.8	37.2	165	2393	650	9425	300	0.87	A	ST34/STSK92	—
NF2HT-20	1-1/4"	31.8	44.3	47.3	125	1813	500	7250	420	1.27	B	ST34/STSK92	—
NF2HT-24	1-1/2"	38.1	50.7	53.7	90	1305	360	5220	500	1.42	B	ST34/STSK92	—
NF2HT-32	2"	50.8	63.5	66.7	78	1131	310	4500	630	1.86	B	ST34/STSK92	—

-50°C / + 135°C (+150°C DISCONTINUOUS) | -58°F / + 275°F (+302°F DISCONTINUOUS)
 FLAME RESISTANCE: (U.S. MSHA CERTIFICATION)

N5HT

SAE J517 100R5 | HIGH TEMPERATURE

TUBE: HIGH TEMPERATURE HYDRAULIC OIL RESISTANT SPECIAL SYNTHETIC RUBBER.
REINFORCEMENT: SYNTHETIC TEXTILE AND 1 HIGH TENSILE STEEL WIRE BRAID.
COVER: OIL AND WEATHER RESISTANT SYNTHETIC RUBBER IMPREGNATED SYNTHETIC BRAID.
APPLICATION: FOW LOW-MEDIUM PRESSURE HYDRAULIC SYSTEMS IN INDUSTRY. COMPRESSORS AND MINING WHERE OPERATING TEMPERATURE ARE UP TO 150°C.

TUBE: CAOUTCHOUC SYNTHÉTIQUE SPÉCIAL RÉSISTANT AUX HUILES ET MINÉRALES.
REINFORCEMENT: TRESSE TEXTILE IMPRÉGNÉE DE CAOUTCHOUC SYNTHÉTIQUE SPÉCIAL
REVÊTEMENT: RÉSISTANT A L'ABRASION, AUX HUILES, CARBURANTS.
APPLICATION: POUR LES SYSTÈMES HYDRAULIQUES A BASSE ET MOYENNE PRESSION DANS L'INDUSTRIE. COMPRESSEURS. L'EXPLOITATION MINIÈRE OU ON EXIGE UNE TEMPÉRATURE JUSQU'A 150°C.



HOSE SIZE I.D.			O.D. HOSE	Max. Working Pressure		Min. Burst Pressure		Min. Bend Radius	Weight	Compatible Fittings		
SIZE	Inch.	mm	mm	BAR	PSI	BAR	PSI	mm	lbs/ft			
N5HT-04	3/16"	4.8	12.9	210	3045	840	12180	75	0.17	—	ST31	R305
N5HT-05	1/4"	6.4	14.5	210	3045	840	12180	85	0.20	—	ST31	R305
N5HT-06	5/16"	8	16.8	157	2277	628	9106	100	0.25	—	ST31	R305
N5HT-08	13/32"	10.3	19.1	140	2030	560	8120	115	0.29	—	ST31	R305
N5HT-10	1/2"	12.7	22.9	122	1770	488	7076	140	0.40	—	ST31	R305
N5HT-12	5/8"	16	27.1	105	1523	420	6090	165	0.49	—	ST31	R305
N5HT-16	7/8"	22.2	30.8	56	812	224	3248	185	0.49	—	—	R305
N5HT-20	1-1/8"	28.6	37.6	43	624	172	2494	230	0.63	—	—	R305
N5HT-24	1-3/8"	34.9	44.5	35	508	140	2030	265	0.79	—	—	R305
N5HT-32	1-13/16"	46	56.4	24	348	96	1392	335	0.95	—	—	R305

-50°C / + 135°C (+150°C DISCONTINUOUS) | -48°F / + 275°F (+302°F DISCONTINUOUS)
 FLAME RESISTANCE: (U.S. MSHA CERTIFICATION) | 1/4" TO 5/8" DOT CERTIFICATE

TUBE: MINERAL, VEGETABLE AND HYDRAULIC OIL RESISTANT SPECIAL SYNTHETIC RUBBER.
REINFORCEMENT: 1 HIGH TENSILE STEEL WIRE BRAID
COVER: OIL, ABRASION AND WEATHER RESISTANT SPECIAL SYNTHETIC RUBBER.
APPLICATION: FOR LOW-MEDIUM PRESSURE HYDRAULIC SYSTEMS IN INDUSTRY AND AGRICULTURE.

TUBE: CAOUTCHOUC SYNTHÉTIQUE SPÉCIAL RÉSISTANT AUX HUILES HYDRAULIQUES, MINÉRALES ET LUBRIFIANTS.
REINFORCEMENT: 1 TRESSE D'ACIER TRÈS RÉSISTANTE.
REVÊTEMENT: CAOUTCHOUC SYNTHÉTIQUE SPÉCIAL, RÉSISTANT A L'ABRASION, AUX HUILES, CARBURANTS ET DÉTERGENTS.
APPLICATION: POUR LES SYSTÈMES HYDRAULIQUES A BASSE ET MOYENNE PRESSION DANS L'INDUSTRIE ET L'AGRICULTURE.



HOSE SIZE I.D.			ROD O.D.	HOSE O.D.	Working Pressure		Burst Pressure		Min. Bend Radius	Weight	Compatible Fittings		
SIZE	Inch.	mm	mm	mm	BAR	PSI	BAR	PSI	mm	lbs/ft			
NFFS-04	1/4"	6.4	11.1	13.2	225	3263	900	13050	100	0.15	A	ST34	—
NFFS-06	3/8"	9.5	15.0	17.2	180	2610	720	10440	130	0.23	A	ST34	—
NFFS-08	1/2"	12.7	18.1	20.4	160	2320	640	9280	180	0.28	A	ST34	—
NFFS-12	3/4"	19.0	25.2	27.5	105	1523	420	6090	240	0.40	A	ST34	—
NFFS-16	1"	25.4	33.1	35.4	88	1276	350	5075	300	0.59	A	ST34	—

-40°C / + 100°C (+125°C DISCONTINUOUS) | -40°F / + 212°F (+257°F DISCONTINUOUS)
 FLAME RESISTANCE: (U.S. MSHA CERTIFICATION)

N5

TUBE: MINERAL, VEGETABLE AND HYDRAULIC OIL RESISTANT SPECIAL SYNTHETIC RUBBER.
REINFORCEMENT: SYNTHETIC TEXTILE AND 1 HIGH TENSILE STEEL WIRE BRAID.
COVER: OIL AND WEATHER RESISTANT SYNTHETIC RUBBER IMPREGNATED SYNTHETIC BRAID.
APPLICATION: FOR LOW-MEDIUM PRESSURE HYDRAULIC SYSTEMS IN INDUSTRY AND AGRICULTURE.

TUBE: CAOUTCHOUC SYNTHÉTIQUE SPÉCIAL RÉSISTANT AUX HUILES HYDRAULIQUES, MINÉRALES.
REINFORCEMENT: INSERTION TEXTILE 1 TRESSE D'ACIER TRÈS RÉSISTANTE.
REVÊTEMENT: TRESSE TEXTILE IMPRÉGNÉE DE CAOUTCHOUC SYNTHÉTIQUE SPÉCIAL RÉSISTANT A L'ABRASION.
APPLICATION: POUR LES SYSTÈMES HYDRAULIQUES A BASSE ET MOYENNE PRESSION DANS L'INDUSTRIE ET L'AGRICULTURE.



HOSE SIZE I.D.			HOSE O.D.	Working Pressure		Burst Pressure		Min. Bend Radius	Weight	Compatible Fittings		
SIZE	Inch.	mm	mm	BAR	PSI	BAR	PSI	mm	lbs/ft			
N5-04	3/16"	4.8	12.9	210	3045	840	12180	75	0.17	—	ST31	R305
N5-05	1/4"	6.4	14.5	210	3045	840	12180	85	0.19	—	ST31	R305
N5-06	5/16"	8	16.8	157	2277	628	9106	100	0.24	—	ST31	R305
N5-08	13/32"	10.3	19.1	140	2030	560	8120	115	0.28	—	ST31	R305
N5-10	1/2"	12.7	22.9	122	1770	488	7076	140	0.38	—	ST31	R305
N5-12	5/8"	16	27.1	105	1523	420	6090	165	0.47	—	ST31	R305
N5-16	7/8"	22.2	30.8	56	812	224	3248	185	0.47	—	—	R305
N5-20	1-1/8"	28.6	37.6	43	624	172	2494	230	0.62	—	—	R305
N5-24	1-3/8"	34.9	44.5	35	508	140	2030	265	0.77	—	—	R305
N5-32	1-13/16"	46	56.4	24	348	96	1392	335	0.92	—	—	R305

-40°C / + 100°C (+125°C DISCONTINUOUS) | -40°F / + 212°F (+257°F DISCONTINUOUS)
 1/4" TO 5/8" DOT CERTIFICATE
 NORMS: ISO 1307



NFJACK

SAE100R2AT/2SN

TUBE: MINERAL, VEGETABLE AND HYDRAULIC OIL RESISTANT SPECIAL SYNTHETIC RUBBER.
REINFORCEMENT: RUBBER.
COVER: 2 HIGH TENSILE STEEL WIRE BRAID
APPLICATION: OIL, ABRASION AND WEATHER RESISTANT SPECIAL SYNTHETIC RUBBER. FOR HIGH PRESSURE HYDRAULIC SYSTEMS IN JACKING APPLICATIONS.

TUBE: CAOUTCHOUC SYNTHÉTIQUE SPÉCIAL RÉSIDANT AUX HUILES HYDRAULIQUES. MINÉRALES ET LUBRIFIANTS.
REINFORCEMENT: 2 TRESSERES D'ACIER TRÈS RÉSIDANTES.
REVÊTEMENT: CAOUTCHOUC SYNTHÉTIQUE SPÉCIAL. RÉSIDANT A L'ABRASION. AUX HUILES. CARBURANTS.
APPLICATION: POUR LES SYSTÈMES HYDRAULIQUES ET SYSTEMES DE SOULEVAGE.



HOSE SIZE I.D.			ROD O.D.	HOSE O.D.	Max. Working Pressure		Min. Burst Pressure		Min. Bend Radius	Weight	Compatible Fittings		
SIZE	Inch.	mm	mm	mm	BAR	PSI	BAR	PSI	mm	lbs/ft			
NFJACK-04	1/4"	6.4	12.8	15	690	10000	1379	20000	80	0.25	A	ST34	—
NFJACK-06	3/8"	9.5	15.0	18.9	690	10000	1379	20000	95	0.36	A	ST34	—

-40°C / + 100°C (+125°C DISCONTINUOUS) | -40°F / + 212°F (+257°F DISCONTINUOUS)
 NORMS: ISO 1307



NFPILOT

NORMS: ISO 1307

TUBE: MINERAL, VEGETABLE AND HYDRAULIC OIL RESISTANT SPECIAL SYNTHETIC RUBBER.
REINFORCEMENT: RUBBER.
COVER: 1 HIGH TENSILE STEEL WIRE BRAID
APPLICATION: OIL, ABRASION AND WEATHER RESISTANT SPECIAL SYNTHETIC RUBBER. FOR PILOT LINES AND HYDRAULIC SYSTEMS.

TUBE: CAOUTCHOUC SYNTHÉTIQUE SPÉCIAL RÉSIDANT AUX HUILES HYDRAULIQUES ET MINÉRALES.
REINFORCEMENT: 1 TRESSERES D'ACIER TRÈS RÉSIDANTE.
REVÊTEMENT: CAOUTCHOUC SYNTHÉTIQUE SPÉCIAL. RÉSIDANT A L'ABRASION. AUX HUILES. CARBURANTS.
APPLICATION: POUR LES LIGNES DE PILOTAGE ET LES SYSTÈMES HYDRAULIQUES.



HOSE SIZE I.D.			ROD O.D.	HOSE O.D.	Max. Working Pressure		Min. Burst Pressure		Min. Bend Radius	Weight	Compatible Fittings		
SIZE	Inch.	mm	mm	mm	BAR	PSI	BAR	PSI	mm	lbs/ft			
NFPILOT-03	3/16"	4.8	8.7	10.5	120	1740	480	6960	20	0.08	—	ST82	—
NFPILOT-04	1/4"	6.4	9.9	11.5	120	1740	480	6960	25	0.10	—	ST82	—
NFPILOT-05	5/16"	8.0	11.5	13.1	120	1740	480	6960	30	0.12	—	ST82	—
NFPILOT-06	3/8"	9.5	13.2	14.8	120	1740	480	6960	40	0.14	—	ST82	—

-40°C / + 100°C (+125°C DISCONTINUOUS) | -40°F / + 212°F (+257°F DISCONTINUOUS)
 FLAME RESISTANCE: (U.S. MSHA CERTIFICATION)
 NORMS: ISO 1307

PUSH-ON RUBBER COVER

TUBE: HYDRAULIC OILS AND HEAT RESISTANT SYNTHETIC RUBBER.
REINFORCEMENT: SPIRAL ARAMID YARN
COVER: BLACK. OIL RESISTANCE.
APPLICATION: FOR USE WITH PUSH-ON FITTINGS AT WORKING PRESSURES OF 250 PSI FOR INDUSTRIAL SERVICE. NON-CONDUCTIVE

TUBE: CAOUTCHOUC SYNTHÉTIQUE RESISTANT A L'HUILE HYDRAULIQUE ET AUX TEMPÉRATURE ÉLEVÉES.
REINFORCEMENT: UN FIL SPIRAL EN ARAMIDE
REVÊTEMENT: NOIR. RESISTANT A L'HUILE
APPLICATION: POUR USAGE AVEC RACCORDS "PUSH-ON".



HOSE SIZE I.D.			HOSE O.D. mm	Working Pressure		Min. Bend Radius mm	Weight lbs/ft	Compatible Fittings		
SIZE	Inch.	mm		BAR	PSI			ST82	ST82	ST82
PUSHRC-04	1/4"	6.4	12.7	17.2	250	64	0.08	—	ST82	—
PUSHRC-05	5/16"	7.9	15.7	17.2	250	76	0.12	—	ST82	—
PUSHRC-06	3/8"	9.5	16.5	17.2	250	76	0.12	—	ST82	—
PUSHRC-08	1/2"	12.7	20.3	17.2	250	127	0.17	—	ST82	—
PUSHRC-10	5/8"	15.9	23.9	17.2	250	152	0.23	—	ST82	—
PUSHRC-12	3/4"	19.1	27.4	17.2	250	178	0.28	—	ST82	—

-29°C / + 99°C
 -20°F / + 210°F

PUSH-ON COTTON COVER

TUBE: HYDRAULIC OILS AND HEAT RESISTANT SYNTHETIC RUBBER.
REINFORCEMENT: ONE TEXTILE BRAID.
COVER: BLACK DYED TEXTILE BRAID. MILDEW AND OIL RESISTANCE.
APPLICATION: FOR LOW-PRESSURE HYDRAULIC AND PNEUMATIC SYSTEMS.

TUBE: CAOUTCHOUC SYNTHÉTIQUE RESISTANT A L'HUILE HYDRAULIQUE ET AUX TEMPÉRATURE ÉLEVÉES.
REINFORCEMENT: UNE TRESSE TEXTILE.
REVÊTEMENT: TEXTILE TEINTÉ NOIR. RESISTANT A L'HUILE ET LA MOISSURE.
APPLICATION: POUR LES SYSTÈMES PNEUMATIQUES ET HYDRAULIQUES À BASSE PRESSION.





HOSE SIZE I.D.			HOSE O.D. mm	Working Pressure		Min. Bend Radius mm	Weight lbs/ft	Compatible Fittings		
SIZE	Inch.	mm		BAR	PSI			ST82	ST82	ST82
PUSHCC-04	1/4"	6.4	12.7	20.7	300	64	0.08	—	ST82	—
PUSHCC-06	3/8"	9.5	16.3	20.7	300	76	0.11	—	ST82	—
PUSHCC-08	1/2"	12.7	19.1	20.7	300	127	0.13	—	ST82	—
PUSHCC-10	5/8"	15.9	23.1	20.7	300	152	0.19	—	ST82	—
PUSHCC-12	3/4"	19.0	26.2	20.7	300	178	0.21	—	ST82	—

-29°C / + 99°C
 -20°F / + 210°F

TUBE: NITRILE
REINFORCEMENT: SPIRAL-PLIED SYNTHETIC FABRIC WITH WIRE HELIX
COVER: BLACK NEOPRENE
APPLICATION: LOW PRESSURE. HIGH TEMPERATURE RETURN LINE OR SUCTION LINE FOR PETROLEUM AND WATER BASED HYDRAULIC FLUIDS. VACUUM RATING 25 IN HG. HR4 WITH HALF THE BEND RADIUS OF TYPICAL SAE100R4.

TUBE: NITRILE
REINFORCEMENT: TRESSE TEXTILE ET UN FIL MÉTALLIQUE EN SPIRALE
REVÊTEMENT: NÉOPRÈNE NOIR
APPLICATION: POUR SUCCION (TAUX DE 25 HG) OU RETOUR DE FLUIDES HYDRAULIQUES. RAYON DE COURBURE 50% PLUS COURT QUE LA SAE100R4 STANDARD.



HOSE SIZE I.D.			ROD O.D.	HOSE O.D.	Working Pressure		Burst Pressure		Min. Bend Radius	Weight	Compatible Fittings		
SIZE	Inch.	mm	mm	mm	BAR	PSI	BAR	PSI	mm	lbs/ft			
N4-12	3/4"	19.0	25.8	29.5	21	300	83	1200	63.5	0.53	—	ST31	HDC29-31
N4-16	1"	25.4	37.3	37.3	17	250	69	1000	76.2	0.65	—	ST34	HDC36-39
N4-20	1-1/4"	31.8	43.0	43.0	14	200	55	800	101.6	0.80	—	ST34	HDC40-43
N4-24	1-1/2"	38.1	49.4	49.4	10	150	41	600	127.0	0.91	—	ST34	HDC44-47
N4-32	2"	50.8	63.0	63.0	7	100	28	400	152.4	1.18	—	ST34	HDC60-63
N4-40	2-1/2"	63.5	75.0	75.0	4	62	17	250	177.8	1.72	—	ST34	HDC68-73
N4-48	3"	76.2	89.2	89.2	4	56	16	225	228.6	2.03	—	ST34	HDC86-91

-40°C / + 135°C | -40°F / + 275°F

FLAME RESISTANCE: (U.S. MSHA CERTIFICATION)



TEFLON

SAE100R14

TUBE: SINTERED TUBE OF POLYTETRAFLUORETHYLENE. (P.T.F.E.)
REINFORCEMENT: SINGLE BRAID OF 303/304 SERIES OF STAINLESS STEEL WIRE
APPLICATION: P.T.F.E. HOSE HAS AN EXCELLENT CHEMICAL RESISTANCE. NON CONTAMINANT PROPERTIES. LOW COEFFICIENT OF FRICTION AND RESISTS DETERIORATION. THEREFORE THE HOSE IS USED GENERALLY IN APPLICATIONS WHERE ALL ARE ONE OF THE ABOVE PROPERTIES IS THE MAIN CRITERIA.

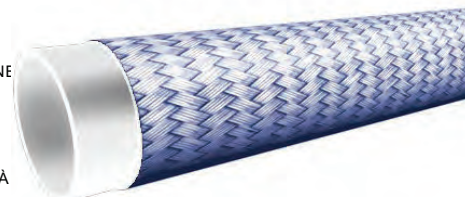
TUBE: TUBE FRITTÉS DE POLYTÉTRAFLUORÉTHYLÈNE. (P.T.F.E.)
REINFORCEMENT: UN BRIN DE SÉRIE 303/304 D'ACIER INOXYDABLE.
APPLICATION: LE BOYAU P.T.F.E. A UNE EXCELLENTE RÉSISTANCE AUX PRODUITS CHIMIQUES ET À LA CONTAMINATION.



HOSE SIZE I.D.			HOSE O.D.	Working Pressure		Burst Pressure		Min. Bend Radius	Compatible Fittings		
SIZE	Inch.	mm	mm	BAR	PSI	BAR	PSI	mm			
TEF-03	1/8"	3.0	6.2	225	3.260	900	13040	40	—	900	—
TEF-04	3/16"	4.8	7.6	190	2.750	760	11000	50	—	ST85	—
TEF-05	1/4"	6.4	8.8	180	2.610	720	10440	75	—	ST85	—
TEF-06	5/16"	8.0	11.0	175	2.540	700	10160	100	—	ST85	—
TEF-07	3/8"	9.5	12.1	165	2.390	660	9560	125	—	ST85	—
TEF-08	13/32"	10.5	13.7	140	2.030	560	8120	135	—	900	—
TEF-10	1/2"	12.7	16.2	120	1.740	480	6960	165	—	ST85	—
TEF-12	5/8"	16.0	18.8	88	1.270	352	5080	200	—	ST85	—
TEF-14	3/4"	19.0	23.1	70	1.010	280	4040	230	—	ST85	—
TEF-16	7/8"	22.2	26.2	60	870	240	3480	230	—	900	—
TEF-18	1"	25.4	29.2	60	870	240	3480	300	—	ST85	—
TEF-20	1.1/8"	29.0	33.1	44	630	176	2520	410	—	900	—

-54°C / + 260°C (-129°F / + 500°F)

TECH12 *HALF BEND RADIUS*

SAE100R12

TUBE: MINERAL, VEGETABLE AND GLYCOL BASED HYDRAULIC OIL RESISTANT SPECIAL SYNTHETIC RUBBER.
REINFORCEMENT: 4 OR 6 HIGH TENSILE STEEL SPIRAL.
COVER: HYDRAULIC OIL, ABRASION AND WEATHER RESISTANT SPECIAL SYNTHETIC RUBBER.
APPLICATION: FOR HYDRAULIC SYSTEMS WITH HIGH PEAK PRESSURES AND ARDUOUS OPERATING CONDITIONS.

TUBE: CAOUTCHOUC SYNTHÉTIQUE SPÉCIAL RÉSIDANT AUX FLUIDES HYDRAULIQUES A BASE D' HUILES MINÉRALES, GLYCOLS ET VÉGÉTALES.
RENFORCEMENT: 4 OU 6 NAPPES SPIRALES EN FIL D' ACIER À HAUTE RÉSIDANCE.
REVÊTEMENT: CAOUTCHOUC SYNTHÉTIQUE SPÉCIAL, RÉSIDANT A L' ABRASION, AUX HUILES ET CARBURANTS.
APPLICATION: POUR LES SYSTÈMES HYDRAULIQUES AVEC DES PULSATIONS DE PRESSION SUPÉRIEURES, DANS DES CONDITIONS SÉVÈRES.



HOSE SIZE I.D.			ROD O.D.	HOSE O.D.	Working Pressure		Burst Pressure		Min. Bend Radius	Weight	Compatible Fittings		
SIZE	Inch.	mm	mm	mm	BAR	PSI	BAR	PSI	mm	lbs/ft			
TECH12-06	3/8"	9.52	17.20	20.25	276	4003	1104	16012	64	0.45	B+C	ST37/STSK92	—
TECH12-08	1/2"	12.70	20.70	23.80	276	4003	1104	16012	89	0.52	B+C	ST37/STSK92	—
TECH12-10	5/8"	15.88	24.60	27.40	276	4003	1104	16012	102	0.71	B+C	ST37/STSK92	—
TECH12-12	3/4"	19.05	27.65	30.70	276	4003	1104	16012	121	0.89	B+C	ST37/STSK92	—
TECH12-16	1"	25.40	34.90	38.00	276	4003	1104	16012	153	1.30	B+C	ST37/STSK92	—
TECH12-20	1-1/4"	31.75	43.90	47.00	207	3002	828	12009	210	1.74	B+C	ST37/STSK92	—
TECH12-24	1-1/2"	38.10	50.40	53.45	172	2495	688	9979	254	1.98	B+C	ST37/STSK92	—
TECH12-32	2"	50.80	63.70	66.70	172	2495	688	9979	318	2.80	B+C	ST37/STSK92	—

-40°C / + 100°C (+125°C DISCONTINUOUS) | -40°F / + 248°F (+257°F DISCONTINUOUS)

NORMS: ISO 1307

TECH13 *HALF BEND RADIUS*

SAE100R13

TUBE: MINERAL, VEGETABLE AND GLYCOL BASED HYDRAULIC OIL RESISTANT SPECIAL SYNTHETIC RUBBER.
REINFORCEMENT: 4 OR 6 HIGH TENSILE STEEL SPIRAL.
COVER: HYDRAULIC OIL, ABRASION AND WEATHER RESISTANT SPECIAL SYNTHETIC RUBBER.
APPLICATION: FOR HYDRAULIC SYSTEMS WITH HIGH PEAK PRESSURES AND ARDUOUS OPERATING CONDITIONS.

TUBE: CAOUTCHOUC SYNTHÉTIQUE SPÉCIAL RÉSIDANT AUX FLUIDES HYDRAULIQUES A BASE D' HUILES MINÉRALES, GLYCOLS ET VÉGÉTALES.
RENFORCEMENT: 4 OU 6 NAPPES SPIRALES EN FIL D' ACIER À HAUTE RÉSIDANCE.
REVÊTEMENT: CAOUTCHOUC SYNTHÉTIQUE SPÉCIAL, RÉSIDANT A L' ABRASION, AUX HUILES ET CARBURANTS.
APPLICATION: POUR LES SYSTÈMES HYDRAULIQUES AVEC DES PULSATIONS DE PRESSION SUPÉRIEURES, DANS DES CONDITIONS SÉVÈRES.



HOSE SIZE I.D.			ROD O.D.	HOSE O.D.	Working Pressure		Burst Pressure		Min. Bend Radius	Weight	Compatible Fittings		
SIZE	Inch.	mm	mm	mm	BAR	PSI	BAR	PSI	mm	lbs/ft			
TECH13-12	3/4"	19.05	29.00	32.15	345	5004	1380	20015	120	1.08	C	—	—
TECH13-16	1"	25.40	35.70	38.70	345	5004	1380	20015	157	1.42	C	—	—
TECH13-20	1-1/4"	31.75	46.80	49.80	345	5004	1380	20015	210	2.49	C	—	—
TECH13-24	1-1/2"	38.10	54.25	57.30	345	5004	1380	20015	255	3.23	C	—	—
TECH13-32	2"	50.80	67.57	71.10	345	5004	1380	20015	635	5.04	C	—	—

-40°C / + 100°C (+125°C DISCONTINUOUS) | -40°F / + 248°F (+257°F DISCONTINUOUS)

FLAME RESISTANCE: (U.S. MSHA CERTIFICATION)

TUBE: MINERAL, VEGETABLE AND GLYCOL BASED HYDRAULIC OIL RESISTANT SPECIAL SYNTHETIC RUBBER.
REINFORCEMENT: 4 OR 6 HIGH TENSILE STEEL SPIRAL.
COVER: HYDRAULIC OIL, ABRASION AND WEATHER RESISTANT SPECIAL SYNTHETIC RUBBER.
APPLICATION: FOR HYDRAULIC SYSTEMS WITH HIGH PEAK PRESSURES AND ARDUOUS OPERATING CONDITIONS.

TUBE: CAOUTCHOUC SYNTHÉTIQUE SPÉCIAL RÉISTANT AUX FLUIDES HYDRAULIQUES A BASE D'HUILES MINÉRALES, GLYCOLS ET VÉGÉTALES.
REINFORCEMENT: 4 OU 6 NAPPEES SPIRALES EN FIL D'ACIER HAUTE RÉISTANCE.
REVÊTEMENT: CAOUTCHOUC SYNTHÉTIQUE SPÉCIAL, RÉISTANT A L'ABRASION, AUX HUILES ET CARBURANTS.
APPLICATION: POUR LES SYSTÈMES HYDRAULIQUES AVEC DES PULSATIONS DE PRESSION SUPÉRIEURES, DANS DES CONDITIONS SÉVÈRES.



HOSE SIZE I.D.			ROD O.D.	HOSE O.D.	Working Pressure		Burst Pressure		Min. Bend Radius	Weight	Compatible Fittings		
SIZE	Inch.	mm	mm	mm	BAR	PSI	BAR	PSI	mm	lbs/ft			
TECH15-06	3/8"	12.70	20.40	23.30	415	6019	1660	24076	101	0.53	C	—	—
TECH15-08	1/2"	15.88	24.50	27.30	415	6019	1660	24076	114	0.73	C	—	—
TECH15-12	3/4"	19.05	28.00	30.50	415	6019	1660	24076	133	0.94	C	—	—
TECH15-16	1"	25.40	35.50	38.70	415	6019	1660	24076	165	1.42	C	—	—
TECH15-20	1-1/4"	31.75	47.20	50.00	415	6019	1660	24076	222	2.68	C	—	—
TECH15-24	1-1/2"	38.10	55.10	58.10	415	6019	1660	24076	266	3.57	C	—	—
TECH15-32	2"	50.80	68.50	71.05	415	6019	1660	24076	660	5.04	C	—	—

-40°C / + 100°C (+125°C DISCONTINUOUS) | -40°F / + 248°F (+257°F DISCONTINUOUS)
 NORMS: ISO 1307

NF4SH

4SH

TUBE: MINERAL, VEGETABLE AND GLYCOL BASED HYDRAULIC OIL RESISTANT SPECIAL SYNTHETIC RUBBER.
REINFORCEMENT: 4 HIGH TENSILE STEEL SPIRAL
COVER: HYDRAULIC OIL, ABRASION AND WEATHER RESISTANT SPECIAL SYNTHETIC
APPLICATION: FOR HYDRAULIC SYSTEMS WITH HIGH PEAK PRESSURES AND ARDUOUS OI CONDITIONS.

TUBE: CAOUTCHOUC SYNTHÉTIQUE SPÉCIAL RÉISTANT AUX FLUIDES HYDRAULI
 BASE D'HUILES MINÉRALES, GLYCOLS ET VÉGÉTALES.
REINFORCEMENT: 4 NAPPEES SPIRALES EN FIL D'ACIER À HAUTE RESISTANCE.
REVÊTEMENT: CAOUTCHOUC SYNTHÉTIQUE SPÉCIAL, RÉISTANT A L'ABRASION, AUX HUI
 CARBURANTS.
APPLICATION: POUR LES SYSTÈMES HYDRAULIQUES AVEC DES PULSATIONS DE PRESSIC
 SUPÉRIEURES, DANS LES CONDITIONS SEVERES.



HOSE SIZE I.D.			ROD O.D.	HOSE O.D.	Working Pressure		Burst Pressure		Min. Bend Radius	Weight	Compatible Fittings		
SIZE	Inch.	mm	mm	mm	BAR	PSI	BAR	PSI	mm	lbs/ft			
NF4SH-24	1-1/2"	38.1	48.8	53	290	4205	1160	16820	560	2.14	C	—	—
NF4SH-32	2"	50.8	50.8	67.6	250	3625	1000	14500	700	2.93	C	—	—

-40°C / + 100°C (+125°C DISCONTINUOUS) | -40°F / + 212°F (+257°F DISCONTINUOUS)
 FLAME RESISTANCE: (U.S. MSHA CERTIFICATION)
 NORMS: DIN 20023 PART 2 TYPE 4SH

TUBE: MINERAL, VEGETABLE AND GLYCOL BASED HYDRAULIC OIL RESISTANT SPECIAL SYNTHETIC RUBBER.
REINFORCEMENT: 4 OR 6 HIGH TENSILE STEEL SPIRAL.
COVER: HYDRAULIC OIL, ABRASION AND WEATHER RESISTANT SPECIAL SYNTHETIC RUBBER.
APPLICATION: FOR HYDRAULIC SYSTEMS WITH HIGH PEAK PRESSURES AND ARDUOUS OPERATING CONDITIONS.

TUBE: CAOUTCHOUC SYNTHÉTIQUE SPÉCIAL RÉSIDANT AUX FLUIDES HYDRAULIQUES A BASE D 'HUILES MINÉRALES, GLYCOLS ET VÉGÉTALES.
REINFORCEMENT: 4 OU 6 NAPPES SPIRALES EN FIL D 'ACIER À HAUTE RÉSIDANCE.
REVÊTEMENT: CAOUTCHOUC SYNTHÉTIQUE SPÉCIAL, RÉSIDANT A L'ABRASION, AUX HUILES ET CARBURANTS.
APPLICATION: POUR LES SYSTÈMES HYDRAULIQUES AVEC DES PULSATIONS DE PRESSION SUPÉRIEURES, DANS DES CONDITIONS SÉVÈRES.



HOSE SIZE I.D.			ROD O.D.	HOSE O.D.	Working Pressure		Burst Pressure		Min. Bend Radius	Weight	Compatible Fittings		
SIZE	Inch.	mm	mm	mm	BAR	PSI	BAR	PSI	mm	lbs/ft			
NF5-06	3/8"	9.5	17	19.3	350	5070	1400	20300	90	0.39	B+C	ST37	—
NF5-08	1/2"	12.7	20.1	22.2	350	5070	1400	20300	115	0.51	B+C	ST37	—
NF5-10	5/8"	16	23.8	26	350	5070	1400	20300	125	0.64	B+C	ST37	—
NF5-12	3/4"	19	28.2	31	350	5070	1400	20300	140	0.90	B+C	ST37	—
NF5-16	1"	25.4	35.1	38.4	350	5070	1400	20300	150	1.32	B+C	ST37	—
NF5-20	1-1/4"	31.8	42.2	45.2	350	5070	1400	20300	350	1.71	B+C	ST37	—
NF5-24*	1-1/2"	38.1	53.7	57.3	345	5000	1380	20000	500	3.21	C	—	—
NF5-32*	2"	50.8	68	71.6	345	5000	1380	20000	630	4.24	C	—	—

-40°C / + 100°C (+125°C DISCONTINUOUS) | -40°F / + 248°F (+257°F DISCONTINUOUS)

* SAE100R13 Compatible

TUBE: MINERAL, VEGETABLE AND GLYCOL BASED HYDRAULIC OIL RESISTANT SPECIAL SYNTHETIC RUBBER.
REINFORCEMENT: 4 OR 6 HIGH TENSILE STEEL SPIRAL.
COVER: HYDRAULIC OIL, ABRASION AND WEATHER RESISTANT SPECIAL SYNTHETIC RUBBER.
APPLICATION: FOR HYDRAULIC SYSTEMS WITH HIGH PEAK PRESSURES AND ARDUOUS OPERATING CONDITIONS.

TUBE: CAOUTCHOUC SYNTHÉTIQUE SPÉCIAL RÉSIDANT AUX FLUIDES HYDRAULIQUES A BASE D 'HUILES MINÉRALES, GLYCOLS ET VÉGÉTALES.
REINFORCEMENT: 4 OU 6 NAPPES SPIRALES EN FIL D 'ACIER À HAUTE RÉSIDANCE.
REVÊTEMENT: CAOUTCHOUC SYNTHÉTIQUE SPÉCIAL, RÉSIDANT A L'ABRASION, AUX HUILES ET CARBURANTS.
APPLICATION: POUR LES SYSTÈMES HYDRAULIQUES AVEC DES PULSATIONS DE PRESSION SUPÉRIEURES, DANS DES CONDITIONS SÉVÈRES.



HOSE SIZE I.D.			ROD O.D.	HOSE O.D.	Working Pressure		Burst Pressure		Min. Bend Radius	Weight	Compatible Fittings		
SIZE	Inch.	mm	mm	mm	BAR	PSI	BAR	PSI	mm	lbs/ft			
NF6-06	3/8"	9.5	17.5	20.6	420	6090	1680	24360	110	0.50	B+C	ST37	—
NF6-08	1/2"	12.7	20.2	23.5	420	6090	1680	24360	120	0.59	B+C	ST37	—
NF6-10	5/8"	16	23.8	27	420	6090	1680	24360	140	0.71	B+C	ST37	—
NF6-12	3/4"	19	28.2	32	420	6090	1680	24360	170	0.99	C	—	—
NF6-16	1"	25.4	35.1	38.1	420	6090	1680	24360	220	1.35	C	—	—
NF6-20	1-1/4"	31.8	46.3	49.3	420	6090	1680	24360	265	2.54	C	—	—
NF6-24*	1-1/2"	38.1	53.7	57.3	420	6090	1750	25375	315	3.18	C	—	—
NF6-32*	2"	50.8	68.4	72	420	6090	1680	24360	600	4.35	C	—	—

-40°C / + 100°C (+125°C DISCONTINUOUS) | -40°F / + 248°F (+257°F DISCONTINUOUS)

FLAME RESISTANCE: (U.S. MSHA CERTIFICATION)

*SAE100R15 Compatible

TUBE: HYDRAULIC OILS. AIR AND WATER BASED FLUIDS RESISTANT POLYESTER.
REINFORCEMENT: HIGH TENSILE POLYESTER FIBER BRAID.
COVER: OIL. ABRASION AND WEATHER RESISTANT POLYURETHANE.
APPLICATION: FOR AIR. WATER. MINERAL AND/OR SYNTHETIC OILS DISCHARGE AT MEDIUM PRESSURE.

TUBE: POLYESTER RÉSISTANT AUX HUILES HYDRAULIQUES. À L'AIR ET AUX FLUIDES À BASE D'EAU.
REINFORCEMENT: TRESSE DE FIBRE EN POLYESTER DE HAUTE RÉSISTANCE.
REVÊTEMENT: POLYURÉTHANE RÉSISTANT AUX HUILES. À L'ABRASION. AUX INTEMPÉRIES.
APPLICATION: PRESSION MOYENNE POUR L'EAU. L'AIR. LES HUILES SYNTHÉTIQUES OU MINÉRALES.



HOSE SIZE I.D.			HOSE O.D. mm	Working Pressure		Burst Pressure		Min. Bend Radius mm	Weight lbs/ft	Compatible Fittings		
SIZE	Inch.	mm		BAR	PSI	BAR	PSI			mm		
NFR7-02	1/8"	3	8	207	3.000	828	12.000	13	0.03	—	3903	—
NFR7-03	3/16"	5	10.7	207	3.000	828	12.000	20	0.05	—	3903/ST82	—
NFR7-04	1/4"	6	12.8	190	2.750	759	11.000	33	0.06	—	ST82	—
NFR7-05	5/16"	8	14.5	173	2.500	690	10.000	46	0.08	—	ST82	—
NFR7-06	3/8"	10	16.6	155	2.250	621	9.000	51	0.10	—	ST82	—
NFR7-08	1/2"	13	20.6	138	2.000	552	8.000	76	0.15	—	ST82	—
NFR7-12	3/4"	19	27	86	1.250	345	5.000	135	0.19	—	*	—

-40°C / + 100°C (+125°C DISCONTINUOUS) | -40°F / + 212°F (+257°F DISCONTINUOUS)
 Limited to +135°F(+57°C) for water-based or fire resistant fluids.

TUBE: HYDRAULIC OILS. AIR AND WATER BASED FLUIDS RESISTANT POLYESTER.
REINFORCEMENT: SINGLE ARAMID BRAID
COVER: OIL. ABRASION AND WEATHER RESISTANT POLYURETHANE.
APPLICATION: FOR AIR. WATER. MINERAL AND/OR SYNTHETIC OILS DISCHARGE AT MEDIUM PRESSURE.

TUBE: POLYESTER RÉSISTANT AUX HUILES HYDRAULIQUES. À L'AIR ET AUX FLUIDES À BASE D'EAU.
REINFORCEMENT: UNE TRESSE EN ARAMIDE
REVÊTEMENT: POLYURÉTHANE RÉSISTANT AUX HUILES. À L'ABRASION. AUX INTEMPÉRIES.
APPLICATION: PRESSION MOYENNE POUR L'EAU. L'AIR. LES HUILES SYNTHÉTIQUES OU MINÉRALES.



HOSE SIZE I.D.			HOSE O.D. mm	Working Pressure		Burst Pressure		Min. Bend Radius mm	Weight lbs/ft	Compatible Fittings		
SIZE	Inch.	mm		BAR	PSI	BAR	PSI			mm		
NFR8-03	3/16"	5	10.7	345	5.000	1380	20.000	38	0.05	—	ST82	—
NFR8-04	1/4"	6	12.8	345	5.000	1380	20.000	51	0.06	—	ST82	—
NFR8-06	3/8"	10	16.6	276	4.000	1104	16.000	64	0.08	—	ST82	—
NFR8-08	1/2"	13	20.6	241	3.500	966	14.000	102	0.13	—	ST82	—
NFR8-12	3/4"	19	27	155	2.250	621	9.000	165	0.20	—	*	—

-40°C / + 100°C | -40°F / + 212°F
 Limited to +135°F(+57°C) for water-based or fire resistant fluids

NFR7T

SAE100R7 TWIN

TUBE: HYDRAULIC OILS. AIR AND WATER BASED FLUIDS RESISTANT POLYESTER.
REINFORCEMENT: HIGH TENSILE POLYESTER FIBER BRAID.
COVER: OIL, ABRASION AND WEATHER RESISTANT POLYURETHANE.
APPLICATION: FOR AIR, WATER, MINERAL AND/OR SYNTHETIC OILS DISCHARGE AT MEDIUM PRESSURE.

TUBE: POLYESTER RÉSISTANT AUX HUILES HYDRAULIQUES. À L'AIR ET AUX FLUIDES À BASE D'EAU.
REINFORCEMENT: TRESSE DE FIBRE EN POLYESTER DE HAUTE RÉSIDENCE.
REVÊTEMENT: POLYURÉTHANE RÉSISTANT AUX HUILES. À L'ABRASION. AUX INTEMPÉRIES.
APPLICATION: PRESSION MOYENNE POUR L'EAU. L'AIR. LES HUILES SYNTHÉTIQUES OU MINÉRALES.



HOSE SIZE I.D.			O.D. HOSE	Max. Working Pressure		Min. Burst Pressure		Min. Bend Radius	Weight	Compatible Fittings		
SIZE	Inch.	mm	mm	BAR	PSI	BAR	PSI	mm	lbs/ft			
NFR7T-03	3/16"	5	21.4	207	3.000	828	12.000	20	0.10	—	ST82	—
NFR7T-04	1/4"	6	25.6	190	2.750	759	11.000	33	0.12	—	ST82	—
NFR7T-05	5/16"	8	29	173	2.500	690	10.000	46	0.16	—	ST82	—
NFR7T-06	3/8"	10	33.2	155	2.250	621	9.000	51	0.20	—	ST82	—
NFR7T-08	1/2"	13	41.2	138	2.000	552	8.000	76	0.30	—	ST82	—

-40°C / + 100°C (+125°C DISCONTINUOUS) | -40°F / + 212°F (+257°F DISCONTINUOUS)
 Limited to +135°F(+57°C) for water-based or fire resistant fluids.

NFR8T

SAE100R8 TWIN

TUBE: HYDRAULIC OILS. AIR AND WATER BASED FLUIDS RESISTANT POLYESTER.
REINFORCEMENT: SINGLE ARAMID BRAID
COVER: OIL, ABRASION AND WEATHER RESISTANT POLYURETHANE.
APPLICATION: FOR AIR, WATER, MINERAL AND/OR SYNTHETIC OILS DISCHARGE AT MEDIUM PRESSURE.

TUBE: POLYESTER RÉSISTANT AUX HUILES HYDRAULIQUES. À L'AIR ET AUX FLUIDES À BASE D'EAU.
REINFORCEMENT: UNE TRESSE EN ARAMIDE
REVÊTEMENT: POLYURÉTHANE RÉSISTANT AUX HUILES. À L'ABRASION. AUX INTEMPÉRIES.
APPLICATION: PRESSION MOYENNE POUR L'EAU. L'AIR. LES HUILES SYNTHÉTIQUES OU MINÉRALES.



HOSE SIZE I.D.			O.D. HOSE	Max. Working Pressure		Min. Burst Pressure		Min. Bend Radius	Weight	Compatible Fittings		
SIZE	Inch.	mm	mm	BAR	PSI	BAR	PSI	mm	lbs/ft			
NFR8T-04	1/4"	6	25.6	345	5.000	1380	20.000	51	0.12	—	ST82	—
NFR8T-06	3/8"	10	33.2	276	4.000	1104	16.000	64	0.16	—	ST82	—
NFR8T-08	1/2"	13	41.2	241	3.500	966	14.000	102	0.26	—	ST82	—

-40°C / + 100°C | -40°F / + 212°F
 Limited to +135°F(+57°C) for water-based or fire resistant fluids

NFR7NC

SAE100R7 NON-CONDUCTIVE

TUBE: HYDRAULIC OILS. AIR AND WATER BASED FLUIDS RESISTANT POLYESTER.
REINFORCEMENT: HIGH TENSILE POLYESTER FIBER BRAID.
COVER: OIL. ABRASION AND WEATHER RESISTANT POLYURETHANE.
APPLICATION: FOR AIR. WATER. MINERAL AND/OR SYNTHETIC OILS DISCHARGE AT MEDIUM PRESSURE.

TUBE: POLYESTER RÉSISTANT AUX HUILES HYDRAULIQUES. À L'AIR ET AUX FLUIDES À BASE D'EAU.
REINFORCEMENT: TRESSE DE FIBRE EN POLYESTER DE HAUTE RÉSTANCE.
REVÊTEMENT: POLYURÉTHANE RÉSISTANT AUX HUILES. À L'ABRASION. AUX INTEMPÉRIES.
APPLICATION: PRESSION MOYENNE POUR L'EAU. L'AIR. LES HUILES SYNTHÉTIQUES OU MINÉRALES.



HOSE SIZE I.D.			HOSE O.D.	Working Pressure SAE100R7		Working Pressure ANSI A92.2		Burst Pressure		Min. Bend Radius	Weight	Compatible Fittings		
SIZE	Inch.	mm		mm	BAR	PSI	BAR	PSI	BAR			PSI	mm	lbs/ft
NFR7NC-03	3/16"	5	10.7	207	3.000	207	3.000	828	12.000	19	0.05	—	ST82	—
NFR7NC-04	1/4"	6	12	190	2.750	207	3.000	759	11.000	38	0.06	—	ST82	—
NFR7NC-05	5/16"	8	14.5	173	2.500	207	3.000	690	10.000	45	0.08	—	ST82	—
NFR7NC-06	3/8"	10	16.3	155	2.250	207	3.000	621	9.000	51	0.10	—	ST82	—
NFR7NC-08	1/2"	13	20.6	138	2.000	207	3.000	621	9.000	76	0.15	—	ST82	—
NFR7NC-12	3/4"	19	27	86	1.250	115	1.660	345	5.000	152	0.19	—	*	—
NFR7NC-16	1"	25	34	69	1.000	92	1.330	276	4.000	203	0.27	—	*	—

-40°C / + 100°C | -40°F / + 212°F

Limited to +135°F(+57°C) for water-based or fire resistant fluids

NFR8NC

SAE100R8 NON-CONDUCTIVE

TUBE: HYDRAULIC OILS. AIR AND WATER BASED FLUIDS RESISTANT POLYESTER.
REINFORCEMENT: SINGLE ARAMID BRAID
COVER: OIL. ABRASION AND WEATHER RESISTANT POLYURETHANE.
APPLICATION: FOR AIR. WATER. MINERAL AND/OR SYNTHETIC OILS DISCHARGE AT MEDIUM PRESSURE.

TUBE: POLYESTER RÉSISTANT AUX HUILES HYDRAULIQUES. À L'AIR ET AUX FLUIDES À BASE D'EAU.
REINFORCEMENT: UNE TRESSE EN ARAMIDE
REVÊTEMENT: POLYURÉTHANE RÉSISTANT AUX HUILES. À L'ABRASION. AUX INTEMPÉRIES.
APPLICATION: PRESSION MOYENNE POUR L'EAU. L'AIR. LES HUILES SYNTHÉTIQUES OU MINÉRALES.



HOSE SIZE I.D.			HOSE O.D.	Working Pressure		Burst Pressure		Min. Bend Radius	Weight	Compatible Fittings		
SIZE	Inch.	mm		mm	BAR	PSI	BAR			PSI	mm	lbs/ft
NFR8NC-04	1/4"	6	12.8	345	5.000	1380	20.000	51	0.06	—	ST82	—
NFR8NC-06	3/8"	10	16.6	276	4.000	1104	16.000	64	0.08	—	ST82	—
NFR8NC-08	1/2"	13	20.6	241	3.500	966	14.000	102	0.13	—	ST82	—
NFR8NC-12	3/4"	19	28	155	2.250	621	9.000	165	0.20	—	*	—

-40°C / + 100°C | -40°F / + 212°F

Limited to +135°F(+57°C) for water-based or fire resistant fluids

NFR7TNC

TUBE: HYDRAULIC OILS. AIR AND WATER BASED FLUIDS RESISTANT POLYESTER.
REINFORCEMENT: HIGH TENSILE POLYESTER FIBER BRAID.
COVER: OIL, ABRASION AND WEATHER RESISTANT POLYURETHANE.
APPLICATION: FOR AIR, WATER, MINERAL AND/OR SYNTHETIC OILS DISCHARGE AT MEDIUM PRESSURE.

TUBE: POLYESTER RÉSISTANT AUX HUILES HYDRAULIQUES. À L'AIR ET AUX FLUIDES À BASE D'EAU.
REINFORCEMENT: TRESSE DE FIBRE EN POLYESTER DE HAUTE RÉSIDANCE.
REVÊTEMENT: POLYURÉTHANE RÉSISTANT AUX HUILES. À L'ABRASION. AUX INTEMPÉRIES.
APPLICATION: PRESSION MOYENNE POUR L'EAU, L'AIR, LES HUILES SYNTHÉTIQUES OU MINÉRALES.

SAE100R7 TWIN NON-CONDUCTIVE



HOSE SIZE I.D.			HOSE O.D.	Working Pressure SAE100R7		Working Pressure ANSI A92.2		Burst Pressure		Min. Bend Radius	Weight	Compatible Fittings		
SIZE	Inch.	mm		BAR	PSI	BAR	PSI	BAR	PSI			mm	lbs/ft	
NFR7TNC-04	1/4"	6	24	190	2.750	207	3.000	759	11.000	38	0.12	—	ST82	—
NFR7TNC-06	3/8"	10	32.6	155	2.250	207	3.000	621	9.000	51	0.20	—	ST82	—
NFR7TNC-08	1/2"	13	41.2	138	2.000	207	3.000	621	9.000	76	0.30	—	ST82	—

-40°C / + 100°C | -40°F / + 212°F

Limited to +135°F(+57°C) for water-based or fire resistant fluids

NFR8TNC

TUBE: HYDRAULIC OILS. AIR AND WATER BASED FLUIDS RESISTANT POLYESTER.
REINFORCEMENT: SINGLE ARAMID BRAID
COVER: OIL, ABRASION AND WEATHER RESISTANT POLYURETHANE.
APPLICATION: FOR AIR, WATER, MINERAL AND/OR SYNTHETIC OILS DISCHARGE AT MEDIUM PRESSURE.

TUBE: POLYESTER RÉSISTANT AUX HUILES HYDRAULIQUES. À L'AIR ET AUX FLUIDES À BASE D'EAU.
REINFORCEMENT: UNE TRESSE EN ARAMIDE
REVÊTEMENT: POLYURÉTHANE RÉSISTANT AUX HUILES. À L'ABRASION. AUX INTEMPÉRIES.
APPLICATION: PRESSION MOYENNE POUR L'EAU, L'AIR, LES HUILES SYNTHÉTIQUES OU MINÉRALES.

SAE100R8 TWIN NON-CONDUCTIVE



HOSE SIZE I.D.			O.D. HOSE	Max. Working Pressure		Min. Burst Pressure		Min. Bend Radius	Weight	Compatible Fittings		
SIZE	Inch.	mm		BAR	PSI	BAR	PSI			mm	lbs/ft	
NFR8TNC-04	1/4"	6	25.6	345	5.000	1380	20.000	51	0.12	—	ST82	—
NFR8TNC-06	3/8"	10	33.2	276	4.000	1104	16.000	64	0.16	—	ST82	—
NFR8TNC-08	1/2"	13	41.2	241	3.500	966	14.000	102	0.26	—	ST82	—

-40°C / + 100°C | -40°F / + 212°F

Limited to +135°F(+57°C) for water-based or fire resistant fluids

TUBE: HYDRAULIC OILS. AIR AND WATER BASED FLUIDS RESISTANT POLYESTER.
REINFORCEMENT: HIGH TENSILE POLYESTER FIBER BRAID.
COVER: OIL. ABRASION AND WEATHER RESISTANT POLYURETHANE.
APPLICATION: FOR AIR. WATER. MINERAL AND/OR SYNTHETIC OILS DISCHARGE AT MEDIUM PRESSURE.

TUBE: POLYESTER RÉSISTANT AUX HUILES HYDRAULIQUES. À L'AIR ET AUX FLUIDES À BASE D'EAU.
REINFORCEMENT: TRESSE DE FIBRE EN POLYESTER DE HAUTE RÉSIDANCE.
REVÊTEMENT: POLYURÉTHANE RÉSISTANT AUX HUILES. À L'ABRASION. AUX INTEMPÉRIES.
APPLICATION: PRESSION MOYENNE POUR L'EAU. L'AIR. LES HUILES SYNTHÉTIQUES OU MINÉRALES.



HOSE SIZE I.D.			HOSE O.D. mm	Working Pressure		Burst Pressure		Min. Bend Radius mm	Weight lbs/ft	Compatible Fittings		
SIZE	Inch.	mm		BAR	PSI	BAR	PSI			mm		
NFR18-04	1/4"	6	12.8	207	3.000	828	12.000	45	0.06	—	ST82	—
NFR18-06	3/8"	10	16.8	207	3.000	828	12.000	76	0.13	—	ST82	—
NFR18-08	1/2"	13	21.3	207	3.000	828	12.000	89	0.17	—	ST82	—

-57°C / + 100°C
 -70°F / + 212°F
 Limited to +150°F(+66°C) for water-based or fire resistant fluids.

- Cold Storage and refrigerated areas.
 - Superior Flexibility in Cold Temperature.

NFR18T

SAE100R18 TWIN

TUBE: HYDRAULIC OILS. AIR AND WATER BASED FLUIDS RESISTANT POLYESTER.
REINFORCEMENT: HIGH TENSILE POLYESTER FIBER BRAID.
COVER: OIL. ABRASION AND WEATHER RESISTANT POLYURETHANE.
APPLICATION: FOR AIR. WATER. MINERAL AND/OR SYNTHETIC OILS DISCHARGE AT MEDIUM PRESSURE.

TUBE: POLYESTER RÉSISTANT AUX HUILES HYDRAULIQUES. À L'AIR ET AUX FLUIDES À BASE D'EAU.
REINFORCEMENT: TRESSE DE FIBRE EN POLYESTER DE HAUTE RÉSIDANCE.
REVÊTEMENT: POLYURÉTHANE RÉSISTANT AUX HUILES. À L'ABRASION. AUX INTEMPÉRIES.
APPLICATION: PRESSION MOYENNE POUR L'EAU. L'AIR. LES HUILES SYNTHÉTIQUES OU MINÉRALES.



HOSE SIZE I.D.			HOSE O.D. mm	Working Pressure		Burst Pressure		Min. Bend Radius mm	Weight lbs/ft	Compatible Fittings		
SIZE	Inch.	mm		BAR	PSI	BAR	PSI			mm		
NFR18T-04	1/4"	6	25.6	207	3.000	828	12.000	45	0.12	—	ST82	—
NFR18T-06	3/8"	10	33.6	207	3.000	828	12.000	76	0.26	—	ST82	—
NFR18T-08	1/2"	13	42.6	207	3.000	828	12.000	89	0.34	—	ST82	—

-57°C / + 100°C
 -70°F / + 212°F
 Limited to +150°F(+66°C) for water-based or fire resistant fluids.

- Cold Storage and refrigerated areas.
 - Superior Flexibility in Cold Temperature.



NFPW1

PRESSURE WASHER (1SC)

TUBE: 150°C(302°F) HOT WATER AND DETERGENT SOLUTIONS RESISTANT SPECIAL SYNTHETIC RUBBER.
REINFORCEMENT: 1 HIGH TENSILE STEEL WIRE BRAID
COVER: OIL, ABRASION AND WEATHER RESISTANT PIN PRICKED SPECIAL SYNTHETIC RUBBER.
APPLICATION: FOR MEDIUM PRESSURE CLEANING APPLICATIONS WITH HOT WATER.

TUBE: CAOUTCHOUC SYNTHÉTIQUE SPÉCIAL RÉSISTANT À 150°C(302°F) EAU CHAUDE. DÉTERGENTS. ECT.
REINFORCEMENT: 1 TRESSE D'ACIER TRÈS RÉSISTANTE.
REVÊTEMENT: CAOUTCHOUC SYNTHÉTIQUE SPÉCIAL. MICROPERFORÉ RÉSISTANT À L'ABRASION. AUX HUILES, CARBURANTS ET DÉTERGENTS.
APPLICATION: POUR PRESSION SUPÉRIEURE DE NETTOYAGE À L'EAU CHAUDE.



HOSE SIZE I.D.			ROD O.D.	HOSE O.D.	Working Pressure		Burst Pressure		Min. Bend Radius	Weight	Compatible Fittings		
SIZE	Inch.	mm	mm	mm	BAR	PSI	BAR	PSI	mm	lbs/ft			
NFPW1-04	1/4"	6.4	10.4	12.2	250	4000	1000	14500	75	0.12	—	STSK11	—
NFPW1-06	3/8"	9.5	13.6	15.5	250	4000	1000	14500	90	0.17	—	STSK11	—
NFPW1-08	1/2"	12.7	17	19	250	4000	1000	14500	130	0.23	—	STSK11	—

-40°C / + 150°C (+125°C DISCONTINUOUS)
 -40°F / + 302°F (+257°F DISCONTINUOUS)



NFPW2

PRESSURE WASHER (2SC)

TUBE: 150°C(302°F) HOT WATER AND DETERGENT SOLUTIONS RESISTANT SPECIAL SYNTHETIC RUBBER.
REINFORCEMENT: 2 HIGH TENSILE STEEL WIRE BRAID
COVER: OIL, ABRASION AND WEATHER RESISTANT PIN PRICKED SPECIAL SYNTHETIC RUBBER.
APPLICATION: FOR MEDIUM PRESSURE CLEANING APPLICATIONS WITH HOT WATER.

TUBE: CAOUTCHOUC SYNTHÉTIQUE SPÉCIAL RÉSISTANT À 150°C(302°F) EAU CHAUDE. DÉTERGENTS. ECT.
REINFORCEMENT: 2 TRESSE D'ACIER TRÈS RÉSISTANTE.
REVÊTEMENT: CAOUTCHOUC SYNTHÉTIQUE SPÉCIAL. MICROPERFORÉ RÉSISTANT À L'ABRASION. AUX HUILES, CARBURANTS ET DÉTERGENTS.
APPLICATION: POUR PRESSION SUPÉRIEURE DE NETTOYAGE À L'EAU CHAUDE.



HOSE SIZE I.D.			ROD O.D.	HOSE O.D.	Working Pressure		Burst Pressure		Min. Bend Radius	Weight	Compatible Fittings		
SIZE	Inch.	mm	mm	mm	BAR	PSI	BAR	PSI	mm	lbs/ft			
NFPW2-06	3/8"	9.5	15	17.1	400	5800	1600	23200	90	0.28	—	STSK11	—

-40°C / + 150°C (+125°C DISCONTINUOUS)
 -40°F / + 302°F (+257°F DISCONTINUOUS)

HORIZON

GENERAL PURPOSE

TUBE: BLACK OIL MIST RESISTANT SYNTHETIC RUBBER.
REINFORCEMENT: MULTIPLE LAYERS OF SYNTHETIC YARNS.
COVER: RED SMOOTH WEATHER AND ABRASION RESISTANT SYNTHETIC RUBBER.
APPLICATION: GENERAL AIR-LINE AND WATER SERVICE BOTH IN PLANT AND OUTDOORS.

TUBE: CAOUTCHOUC SYNTHÉTIQUE NOIR.
REINFORCEMENT: MULTIPLE COUCHE DE FIL SYNTHÉTIQUE.
REVÊTEMENT: CAOUTCHOUC ROUGE LISSE SYNTHÉTIQUE RESISTANT A L'ABRASION ET AUX INTÉMPÉRIES.
APPLICATION: USAGE GÉNÉRAL POUR L'AIR ET L'EAU



HOSE SIZE I.D.			HOSE O.D. mm	Working Pressure		Weight lbs/ft	Compatible Fittings		
SIZE	Inch.	mm		BAR	PSI				
HORIZON-04	1/4"	6.4	13.5	250	0.11	—	ST82	—	
HORIZON-06	3/8"	9.5	17.8	250	0.17	—	ST82	—	
HORIZON-08	1/2"	12.7	21.3	250	0.22	—	ST82	—	
HORIZON-10	5/8"	15.9	24.9	250	0.27	—	ST31	—	
HORIZON-12	3/4"	19.1	29.0	250	0.35	—	ST34	—	
HORIZON-16	1"	25.4	36.8	200	0.54	—	ST34	—	
HORIZON-20	1-1/4"	31.8	44.0	200	0.75	—	ST34	—	
HORIZON-24	1-1/2"	38.1	52.07	150	1.04	—	ST34	—	
HORIZON-32	2"	50.8	66.04	150	1.47	—	ST34	—	

-30°C TO +80°C (-22°F TO +180°F)

GAUNTLET

PRESSURE WASHER

TUBE: NITRILE SYNTHETIC RUBBER
REINFORCEMENT: ONE STEEL BRAIDED WIRE
COVER: YELLOW OIL-RESISTANT SYNTHETIC RUBBER
APPLICATION: FOR USE ON PRESSURE WASHER MACHINES WITH WORKING PRESSURES UP TO 3000 PSI. IT'S SUPER ABRASION-RESISTANT COVER PROVIDES MAXIMUM PROTECTION AGAINST ADVERSE EFFECT OF OIL AND ANIMAL FATS.

TUBE: CAOUTCHOUC SYNTHÉTIQUE EN NITRILE
REINFORCEMENT: UN FIL D'ACIER TRESSÉ
REVÊTEMENT: CAOUTCHOUC SYNTHÉTIQUE JAUNE RESISTANT A L'HUILE
APPLICATION: POUR UTILISATION SUR DES MACHINES A LAVER JUSQU'A 3000 PSI. SON ANTI-ABRASION FOURNIT UNE PROTECTION MAXIMALE CONTRE L'HUILE ET LA GRAISSE ANIMALE.



HOSE SIZE I.D.			HOSE O.D. mm	Working Pressure		Weight lbs/ft	Compatible Fittings		
SIZE	Inch.	mm		BAR	PSI				
GAUN-06	3/8"	9.5	17.5	207	3000	0.24	—	STSK11	—
GAUN-08	1/2"	12.7	20.8	207	3000	0.32	—	STSK11	—

-20°F to 250°F (-29°C to 121°C)

J30R7

FUEL LINE/PVC/EMISSION

TUBE: BLACK CHEMIGUM
REINFORCEMENT: TWO SYNTHETIC SPIRAL
COVER: CHLOROSULFONATED POLYETHYLENE
APPLICATION: A MULTIPURPOSE FUEL HOSE THAT CAN BE USED AS A FUEL LINE, PVC CONNECTION, EMISSION CONTROL LINE OR FUEL RETURN LINE. UNLEADED GASOLINE, DIESEL FUEL, GASOLINE BLENDS OF ETHANOL(E-10), E85

TUBE: CHEMIGUM NOIR
REINFORCEMENT: DEUX SPIRALES SYNTHÉTIQUES
REVÊTEMENT: POLYÉTHYLENE CHLOROSULFONE
APPLICATION: UN BOYAU POLYVALENT DE CARBURANT POUVANT ÊTRE UTILISÉ COMME UNE LIGNE DE CARBURANT, CONNECTION PVC, HOSE DE CONTRÔLE DES ÉMISSIONS OU UNE HOSE DE RETOUR DE CARBURANT. ESSENCE SANS PLOMB, CARBURANT DIESEL, ESSENCE MÉLANGE D'ÉTHANOL (E10), E85



HOSE SIZE I.D.			HOSE O.D.	Working Pressure	Burst Pressure	Weight	Compatible Fittings		
SIZE	Inch.	mm	mm	PSI	PSI	lbs/ft			
J30R7-02	1/8"	3.175	0.34	50	250	0.05	—	—	—
J30R7-03	3/16"	4.763	0.41	50	250	0.06	—	—	—
J30R7-04	1/4"	6.350	0.50	50	250	0.09	—	—	—
J30R7-05	5/16"	7.938	0.56	50	250	0.11	—	—	—
J30R7-06	3/8"	9.525	0.63	50	250	0.12	—	—	—
J30R7-08	1/2"	12.700	0.78	35	175	0.18	—	—	—
J30R7-10	5/8"	15.875	0.94	35	175	0.24	—	—	—
J30R7-12	3/4"	19.050	1.13	35	175	0.42	—	—	—

-40°F to 257°F (-40°C to 125°C)

R6

100R6/EN 854 R6

TUBE: NITRITE
REINFORCEMENT: ONE TEXTILE BRAID
COVER: NEOPRENE
APPLICATION: 3/16"-3/4" HOSE FOR LOW-PRESSURE TEXTILE REINFORCED APPLICATIONS INCLUDING PETROLEUM AND WATER-BASED FLUIDS FOR USE IN FLEX FUEL LINES, POWER STEERING RETURN, LUBE LINES AND AIR LINES. NOT FOR BRAKE APPLICATIONS.

TUBE: NITRITE
REINFORCEMENT: UNE TRESSE TEXTILE
REVÊTEMENT: NEOPRENE
APPLICATION: BOYAU DE 3/16"-3/4" POUR APPLICATIONS RENFORCÉES TEXTILES À BASSE PRESSION, Y COMPRIS LES FLUIDES DE PÉTROLE ET À BASE D'EAU, DESTINÉS À ÊTRE UTILISÉS DANS LES CONDUITES À CARBURANT FLEX, LA LIGNE DE RETOUR D'UNE DIRECTION ASSISTÉE, LES CONDUITES À LUBRIFIANT ET LES LIGNES À AIR. PAS POUR LES APPLICATIONS DE FREIN.



HOSE SIZE I.D.			HOSE O.D.	Working Pressure	Burst Pressure	Weight	Compatible Fittings		
SIZE	Inch.	mm	mm	PSI	PSI	lbs/ft			
R6-03	3/16"	4.8	11.1	500	2000	0.07	—	—	—
R6-04	1/4"	6.4	12.7	400	1600	0.09	—	—	—
R6-05	5/16"	7.9	14.2	400	1600	0.09	—	—	—
R6-06	3/8"	9.5	15.9	400	1600	0.11	—	—	—
R6-08	1/2"	12.7	19.8	400	1600	0.16	—	—	—
R6-10	5/8"	15.9	23	350	1400	0.18	—	—	—
R6-12	3/4"	19.0	26.6	300	1200	0.24	—	—	—

-40°F to 212°F (-40°C to 100°C)



J20R3

AUTO HEATER

TUBE: BLACK HEAT RESISTANT EPDM SYNTHETIC RUBBER. RESISTANT TO ANTI-FREEZE SOLUTIONS.
REINFORCEMENT: TWO LAYERS OF SYNTHETIC YARNS.
COVER: HEAT RESISTANT EPDM RUBBER.
APPLICATION: FOR USE IN GENERAL INDUSTRIAL AND AUTOMOTIVE SERVICE.

TUBE: CAOUTCHOUC EPDM SYNTHÉTIQUE NOIR RESISTANT A L'ANTIGEL.
REINFORCEMENT: DEUX COUCHES DE FIL SYNTHÉTIQUE.
REVÊTEMENT: CAOUTCHOUC EPDM RESISTANT À LA CHALEUR.
APPLICATION: USAGE GÉNÉRAL INDUSTRIEL ET AUTOMOBILE.



HOSE SIZE I.D.			HOSE O.D. mm	Working Pressure PSI	Weight lbs/ft	Compatible Fittings		
SIZE	Inch.	mm						
J20R3-08	1/2"	12.7	0.79	60	0.21	—	—	—
J20R3-10	5/8"	15.875	0.91	60	0.23	—	—	—
J20R3-12	3/4"	19.05	1.06	50	0.34	—	—	—
J20R3-16	1"	25.4	1.38	50	0.52	—	—	—

-35°C TO +105°C (-30°F TO +220°F)



BRAKE

AIR BRAKE HOSE / SAE J1402A

TUBE: BLACK VERSIGARD (EPDM)
REINFORCEMENT: TWO SPIRAL SYNTHETIC
COVER: BLACK VERSIGARD (EPDM)
APPLICATION: DESIGNED FOR COMPRESSED AIR BRAKE SYSTEMS MORE COMMONLY FOUND ON HEAVY-DUTY TRUCKS.

TUBE: VERSIGARD NOIR (EPDM)
REINFORCEMENT: DEUX SPIRALES SYNTHÉTIQUES
REVÊTEMENT: VERSIGARD NOIR (EPDM)
APPLICATION: CONÇU POUR LES SYSTÈMES DE FREIN A L'AIR COMPRIMÉ. GÉNÉRALEMENT UTILISÉ SUR LES VÉHICULES LOURDS.



HOSE SIZE I.D.			HOSE O.D. mm	Working Pressure PSI	Weight lbs/ft	Compatible Fittings		
SIZE	Inch.	mm						
BRAKE-06	3/8"	9.525	0.75	145	0.17	—	—	—
BRAKE-08	1/2"	12.7	0.88	145	0.21	—	—	—

-40°C TO + 93°C (-40°F TO +200°F)

3903-02102

MALE NPT

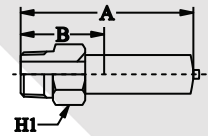

PART. REF.	HOSE BORE			THREAD	DIMENSIONS					
	DN	INCH	SIZE	NPTF	A	B	I.D.		H1	H2
3903 - 02102	3	1/8	- 02	1/8 - 27	33	20	0.8		12.7	

3903-02142

MALE NPT SWIVEL

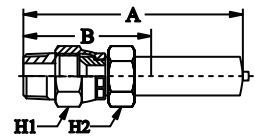

PART. REF.	HOSE BORE			THREAD	DIMENSIONS					
	DN	INCH	SIZE	NPTF	A	B	I.D.		H1	H2
3903 - 02142	3	1/8	- 02	1/8 - 27	49	36	0.8		12.7	14.3

3903-02543

FEMALE JIC

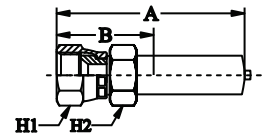

PART. REF.	HOSE BORE			THREAD	DIMENSIONS					
	DN	INCH	SIZE	JIC	A	B	I.D.		H1	H2
3903 - 02543	3	1/8	- 02	3/8 - 24	40.1	28	0.8		12.7	14.3

3903-02544

FEMALE JIC

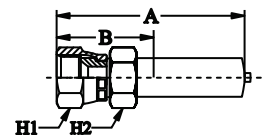

PART. REF.	HOSE BORE			THREAD	DIMENSIONS					
	DN	INCH	SIZE	JIC	A	B	I.D.		H1	H2
3903 - 02544	3	1/8	- 02	7/16 - 20	41.5	29	0.8		12.7	15.88

PART NO.		RANGE OF USE	DIMENSION (inch)			
BLACK	YELLOW		I.D.	O.D.	WALL	PITCH
SPT0203	SPT0203Y	02 > 03	0.40	0.50	0.06	0.40
SPT0204	SPT0204Y	02 > 04	0.45	0.57	0.06	0.48
SPT0408	SPT0408Y	04 > 08	0.55	0.69	0.07	0.57
SPT0810	SPT0810Y	08 > 10	0.80	0.96	0.08	0.82
SPT1016	SPT1016Y	10 > 16	1.00	1.18	0.09	0.94
SPT1620	SPT1620Y	16 > 20	1.26	1.44	0.09	1.18
SPT2024	SPT2024Y	20 > 24	1.50	1.74	0.12	1.38
SPT2432	SPT2432Y	24 > 32	2.00	2.28	0.14	1.57
SPT3240	SPT3240Y	32 > 40	2.40	2.70	0.15	1.60
SPT4850	SPT4850Y	48 > 50	2.83	3.19	0.18	1.78
SPT6470	SPT6470Y	64 > 70	3.43	3.87	0.22	2.17
SPT7076	SPT7076Y	70 > 76	5.07	5.51	0.22	2.17

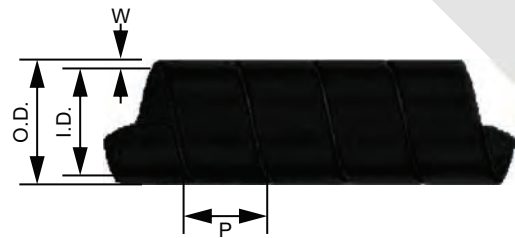

PART NO.	SUGGESTED HOSE	DIMENSION (inch)	
		FLAT I.D.	ROUND O.D.
NS - 3898	NF1 - 04	1.19	0.71
NS - 3899	NF2 - 04	1.25	0.77
NS - 3900	NF1 - 06	1.50	0.90
NS - 3901	NF2 - 06/TECH - 06	1.66	1.00
NS - 3902	NF1 - 08	1.88	1.14
NS - 3902A	NF2 - 08/TECH - 08	1.97	1.21
NS - 3903	NF1 - 10	2.03	1.25
NS - 39031A	NF2 - 10/TECH - 10	2.13	1.30
NS - 3903A	NF1 - 12	2.25	1.38
NS - 3903AA	NF2 - 12/TECH - 12	2.50	1.53
NS - 3904	NF1 - 16	2.56	1.59
NS - 3905	NF2 - 12/TECH - 12	2.81	1.75
NS - 3905A	TECH - 16	3.00	1.85
NS - 3905AA	NF1 - 20/TECH - 20	3.31	2.07
NS - 3906	NF2 - 20/TECH - 20	3.63	2.25
NS - 3907	NF1 - 24	3.81	2.38
NS - 3907A	NF2 - 24/TECH - 24	4.06	2.54
NS - 3907B		4.25	2.64
NS - 3907C	NF1 - 32	4.65	2.87
NS - 3908	NF2 - 32/TECH - 32	4.75	2.96
NS - 3909		5.31	3.34
NS - 3910		5.81	3.66



PART NO.	FOR DIMENSIONS BETWEEN	QTY PER PACK
SP-MICRO	.04 TO 0.40"	20
SP-STANDARD	.16 TO 0.91"	10
SP-XL	.47 TO 1.70"	4
SP-MIXED	.04 TO 1.70"	10 (4pcs MIC, 4pcs STD, 2pcs XL)

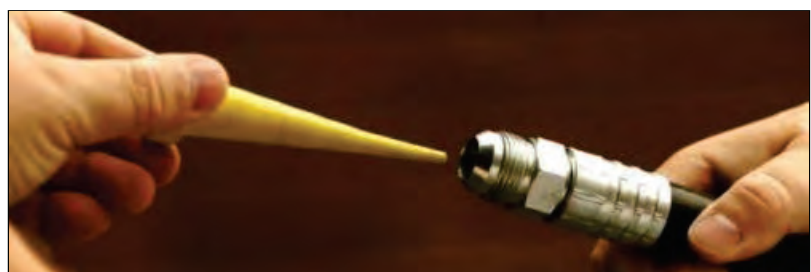

PART NO.		DIMENSION (inch)
w/o Velcro	w/ Velcro	I.D.
FS - 04		0.25
FS - 05		0.31
FS - 06		0.37
FS - 07		0.44
FS - 08		0.50
FS - 10	VFS - 10	0.63
FS - 12	VFS - 12	0.75
FS - 14	VFS - 14	0.88
FS - 16	VFS - 16	1.00
FS - 18	VFS - 18	1.13
FS - 20	VFS - 20	1.25
FS - 22	VFS - 22	1.37
FS - 24	VFS - 24	1.50
FS - 26	VFS - 26	1.63
FS - 28	VFS - 28	1.75
FS - 32	VFS - 32	2.00
FS - 36	VFS - 36	2.25
FS - 40	VFS - 40	2.50
FS - 44	VFS - 44	2.75
FS - 48	VFS - 48	3.00
FS - 52	VFS - 52	3.25
FS - 56	VFS - 56	3.50
FS - 60	VFS - 60	3.75
FS - 64	VFS - 64	4.00
FS - 72		4.50
FS - 80		5.00

Continuous Operating Temperature: 500°F (260°C)
 Maximum short term exposure: 3000°F (1650°C)



NAG

SPRING GUARD STEEL

PART NO.	SUGGESTED HOSE				
	R15	R13	R12	1SN	2SN
NAG - 0560				- 04	
NAG - 0720				- 06	- 04/- 05
NAG - 0940	- 06		- 06	- 08	- 06
NAG - 1060	- 08		- 08	- 10	- 08
NAG - 1180			- 10	- 12	
NAG - 1340	- 12		- 12		- 12
NAG - 1410		- 12			
NAG - 1650	- 16	- 16	- 16	- 16	- 16
NAG - 2010			- 20	- 20	- 20
NAG - 2170	- 20	- 20		- 24	
NAG - 2280					
NAG - 2410	- 24	- 24			
NAG - 2830			- 32	- 32	- 32
NAG - 2970		- 32			



*Also available Nuvo Polyurethane Sleeve (NPTS-XXXX-Y)

**EMBOUTS “DEUX PIÈCES”
TWO PIECES INSERT
2020**



CRIMPED FITTINGS

FITTINGS - PART NUMBERING SYSTEM

FIRST DIGIT

The numbers stated in this position, refer respectively to the following descriptions:

- 1 = Nuvo ST Type Male
- 2 = Nuvo ST Type Female



SECOND AND THIRD DIGIT

ST DESCRIPTION

- 03 BSP Banjo
- 05 BSP Parallel Thread (60° cone)
- 06 BSP Parallel Thread (Flat face)
- 07 BSP Male Tapered Thread - JIS BSP Female
- 08 BSP Parallel Thread O'Ring (60° cone)
- 09 Metric Banjo
- 10 Metric Thread (60° cone superlight)
- 11 Male Metric Thread (24° cone light type)
- 12 Male Metric Thread (24° cone heavy type)
- 13 Metric Thread (Multiseal cone)
- 15 Female Metric Thread (24° cone O'Ring light type)
- 16 Female Metric Thread (24° cone O'Ring heavy type)
- 17 Metric Thread (French Millimetric)
- 18 Metric Thread (French gaz)
- 20 DIN Metric Standpipe L.T.
- 21 DIN Metric Standpipe H.T.
- 25 JIC Thread (37° cone)
- 27 JIC Thread double hexag. (37° cone)
- 24 ORFS type
- 26 SAE Thread (45° cone)
- 28 NPTF/NPSM Thread
- 30 SAE O'Ring Thread
- 33 Code 61 SAE flange 3000 psi
- 36 Code 62 SAE flange 6000 psi
- 38 JIS (Toyota) Thread
- 39 Supercat flange
- 40 JIS (Komatsu) Thread
- 41 NPTF Swivel Male
- 43 SAE O'Ring Thread Swivel Male
- 44 ORFS Long Drop Elbow
- 47 JIC Thread (37° cone)
- 49 Wash Cleaning Female



FOURTH DIGIT

- | | | |
|-----------------|-----------------|------------------|
| 1 = Straight | 4 = 45° Swept | 8 = Compact type |
| 2 = 22.5° Swept | 6 = 60° Swept | 9 = 90° Swept |
| 3 = 30° Swept | 7 = 67.5° Swept | |



FIFTH DIGIT

- 3 = Slip-on Nut
- 2 = Thurst-wire Nut
- 1 = Crimped-back Nut - flange
- 0 = Male/Ferrule





CRIMPING PARAMETERS

NUVO TYPE - "TWO-PIECE COUPLINGS"

FULL LENGTH FLAT CRIMP: DIE POSITION AFTER CRIMPING

DIE POSITION AFTER CRIMPING FOR FULL LENGTH AT CRIMP OF TWO-PIECE SERIES COUPLING

Coupling must be positioned in the dies in such a way that at the end of crimping stroke, die finger's back edge must align over this Cylindrical Zone of the insert.

CORRECT DIE POSITION AT THE END OF CRIMPING STROKE

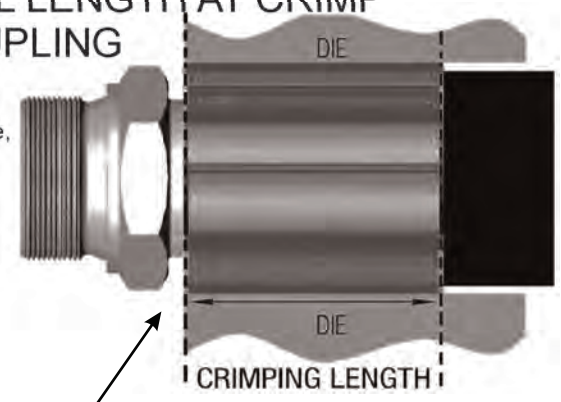

Description

Reference

FERRULE NUVO

SKIVE FERRULE FOR WIRE BRAID HOSES	STSK11
SKIVE FERRULE FOR WIRE BRAID AND SPIRAL HOSES	STSK92
NO SKIVE FERRULE FOR TEXTILE BRAID HOSES	ST31
NO SKIVE FERRULE FOR WIRE BRAID HOSES	ST34
NO SKIVE FERRULE FOR SPIRAL HOSES	ST37
NO SKIVE FERRULE FOR COMPACT AND THERMOPLASTIC HOSES	ST82
NO SKIVE FERRULE FOR TEFLON HOSES	ST85

ST31

NON - SKIVE FERRULE FOR TEXTILE BRAID HOSES

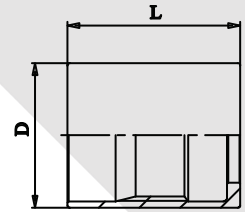

PART. REF.	HOSE BORE			DIMENSIONS					
	DN	INCH	SIZE	D	L				
ST31 - 03	5	3/16	- 03	17.5	27.0				
ST31 - 04	6	1/4	- 04	19.3	30.0				
ST31 - 05	8	5/16	- 05	21.0	32.0				
ST31 - 06	10	3/8	- 06	24.0	32.0				
ST31 - 08	12	1/2	- 08	28.4	34.0				
ST31 - 10	16	5/8	- 10	33.0	37.0				
ST31 - 12	19	3/4	- 12	37.0	43.0				
ST31 - 16	25	1	- 16	43.5	51.0				

ST34

NON - SKIVE FERRULE FOR WIRE BRAID HOSES

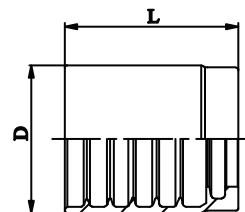

PART. REF.	HOSE BORE			DIMENSIONS					
	DN	INCH	SIZE	D	L				
ST34 - 03	5	3/16	- 03	21.0	22.9				
ST34 - 04	6	1/4	- 04	23.0	30.0				
ST34 - 05	8	5/16	- 05	24.0	30.0				
ST34 - 06	10	3/8	- 06	26.0	31.0				
ST34 - 08	12	1/2	- 08	29.0	34.0				
ST34 - 10	16	5/8	- 10	33.0	37.0				
ST34 - 12	19	3/4	- 12	37.0	42.0				
ST34 - 16	25	1	- 16	46.0	50.5				
ST34 - 20	31	1.1/4	- 20	59.0	57.3				
ST34 - 24	38	1.1/2	- 24	67.0	64.8				
ST34 - 32	51	2	- 32	80.0	68.3				
ST34 - 40	63	2.1/2	- 40	96.0	82.0				
ST34 - 48	76	3	- 48	*	*				

ST37

NON - SKIVE FERRULE FOR SPIRAL HOSES

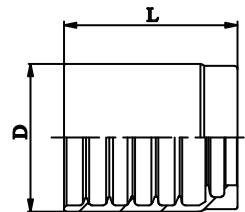

PART. REF.	HOSE BORE			DIMENSIONS					
	DN	INCH	SIZE	D	L				
ST37 - 06	10	3/8	- 06	30.7	31.9				
ST37 - 08	12	5/16	- 08	34.5	34.0				
ST37 - 10	16	5/8	- 10	38.3	35.8				
ST37 - 12	19	3/4	- 12	44.7	44.7				
ST37 - 16	25	1	- 16	51.0	51.0				
ST37 - 20	31	1.1/4	- 20	59.8	59.8				
ST37 - 24	38	1.1/2	- 24	67.0	67.1				
ST37 - 32	51	2	- 32	81.4	72.0				

ST82

NON - SKIVE FERRULE FOR COMPACT AND THERMOPLASTIC HOSES

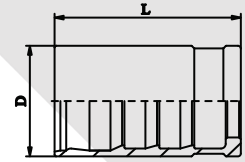

PART. REF.	HOSE BORE			DIMENSIONS						
	DN	INCH	SIZE	D	L					
ST82 - 03	5	3/16	- 03	14.0	26.3					
ST82 - 04	6	1/4	- 04	18.0	29.7					
ST82 - 05	8	5/16	- 05	19.0	31.7					
ST82 - 06	10	3/8	- 06	22.0	33.0					
ST82 - 08	12	1/2	- 08	26.0	34.0					
ST82 - 12	19	3/4	- 12	33.0	41.6					

ST85

NON - SKIVE FERRULE FOR TEFLON HOSES

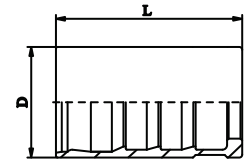

PART. REF.	HOSE BORE			DIMENSIONS						
	DN	INCH	SIZE	D	L					
ST85 - 03	5	3/16	- 03	14.0	25.0					
ST85 - 04	6	1/4	- 04	15.0	28.2					
ST85 - 05	8	5/16	- 05	18.0	29.0					
ST85 - 06	10	3/8	- 06	19.0	30.0					
ST85 - 08	12	1/2	- 08	23.0	32.0					
ST85 - 10	16	5/8	- 10	26.8	35.0					
ST85 - 12	19	3/4	- 12	32.0	41.5					
ST85 - 16	2	1	- 16	38.5	52.0					

STSK11

SKIVE TYPE FERRULE FOR WIRE BRAID HOSES

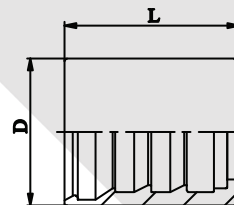

PART. REF.	HOSE BORE			DIMENSIONS					
	DN	INCH	SIZE	D	L				
STSK11 - 03	5	3/16	- 03	17.0	23.9				
STSK11 - 04	6	1/4	- 04	19.5	28.0				
STSK11 - 05	8	5/16	- 05	20.0	28.6				
STSK11 - 06	10	3/8	- 06	23.0	30.0				
STSK11 - 08	12	1/2	- 08	26.7	32.0				
STSK11 - 10	16	5/8	- 10	32.0	38.0				
STSK11 - 12	19	3/4	- 12	35.8	41.7				
STSK11 - 16	25	1	- 16	43.0	47.0				
STSK11 - 20	31	1.1/4	- 20	50.5	59.0				
STSK11 - 24	38	1.1/2	- 24	57.0	70.0				
STSK11 - 32	51	2	- 32	70.0	72.0				

STSK92

SKIVE TYPE FERRULE FOR WIRE BRAID AND SPIRAL HOSES

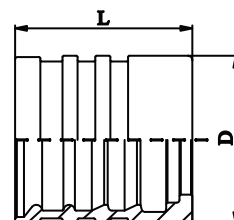

PART. REF.	HOSE BORE			DIMENSIONS					
	DN	INCH	SIZE	D	L				
STSK92 - 04	6	1/4	- 04	22.0	30.0				
STSK92 - 05	8	5/16	- 05	24.0	31.0				
STSK92 - 06	10	3/8	- 06	26.0	33.0				
STSK92 - 08	12	1/2	- 08	30.0	34.0				
STSK92 - 10	16	5/8	- 10	33.0	39.0				
STSK92 - 12	19	3/4	- 12	38.0	40.0				
STSK92 - 16	25	1	- 16	46.0	54.0				
STSK92 - 20	31	1.1/4	- 20	57.0	60.0				
STSK92 - 24	38	1.1/2	- 24	64.0	70.0				
STSK92 - 32	51	2	- 32	79.1	72.0				

ST12810(SAE J516)
NPTF MALE 60° CONE SEAT

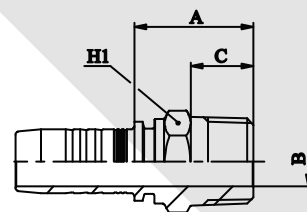

PART. REF.	HOSE BORE			THREAD	DIMENSIONS					
	DN	INCH	SIZE	NPTF	B	A	C			H1
ST12810 - 03 - 02	5	3/16	- 03	1/8 - 27	3.1	23.6	10.5			12
ST12810 - 03 - 04	5	3/16	- 03	1/4 - 18	3.1	29.1	15.0			17
ST12810 - 04 - 02	6	1/4	- 04	1/8 - 27	4.1	24.1	10.5			12
ST12810 - 04 - 04	6	1/4	- 04	1/4 - 18	4.1	28.8	14.5			14.3
ST12810 - 04 - 06	6	1/4	- 04	3/8 - 18	4.1	31.9	16.75			19
ST12810 - 04 - 08	6	1/4	- 04	1/2 - 14	4.1	34.5	19.6			22
ST12810 - 05 - 04	8	5/16	- 05	1/4 - 18	5.5	30.0	14.5			14.3
ST12810 - 05 - 06	8	5/16	- 05	3/8 - 18	5.5	31.9	16.0			19
ST12810 - 06 - 04	10	3/8	- 06	1/4 - 18	7.0	30.5	14.5			19
ST12810 - 06 - 06	10	3/8	- 06	3/8 - 18	7.0	29.0	14.5			19
ST12810 - 06 - 08	10	3/8	- 06	1/2 - 14	7.0	34.8	19.3			22
ST12810 - 08 - 06	12	1/2	- 08	3/8 - 18	9.5	29.5	14.5			19
ST12810 - 08 - 08	12	1/2	- 08	1/2 - 14	9.5	35.2	19.3			22
ST12810 - 08 - 12	12	1/2	- 08	3/4 - 14	9.5	35.4	19.5			27
ST12810 - 10 - 08	16	5/8	- 10	1/2 - 14	12.0	30.7	19.3			24
ST12810 - 10 - 12	16	5/8	- 10	3/4 - 14	12.0	40.2	19.5			27
ST12810 - 12 - 08	19	3/4	- 12	1/2 - 14	15.0	37.1	19.3			27
ST12810 - 12 - 12	19	3/4	- 12	3/4 - 14	15.0	36.9	19.3			27
ST12810 - 12 - 16	19	3/4	- 12	1 - 11.5	15.0	46.0	24.1			36
ST12810 - 14 - 16	22	7/8	- 16	1 - 11.5	*	*	*			*
ST12810 - 16 - 12	25	1	- 16	3/4 - 14	15.0	38.9	19.3			36
ST12810 - 16 - 16	25	1	- 16	1 - 11.5	19.7	43.7	24.1			36
ST12810 - 16 - 20	25	1	- 16	1.1/4 - 11.5	26.0	56.3	25.0			46
ST12810 - 18 - 20	28	1.1/8	- 20	1.1/4 - 11.5	*	*	*			*
ST12810 - 20 - 20	31	1.1/4	- 20	1.1/4 - 11.5	25.0	56.4	25.0			46
ST12810 - 22 - 24	35	1.3/8	- 24	1.1/2 - 11.5	*	*	*			*
ST12810 - 24 - 24	38	1.1/2	- 24	1.1/2 - 11.5	32.0	57.9	25.5			50
ST12810 - 29 - 32	46	1.5/8	- 32	2 - 11.5	*	*	*			*
ST12810 - 32 - 32	51	2	- 32	2 - 11.5	42.0	64.6	26.0			65
ST12810 - 40 - 40	63	2.1/2	- 40	2.1/2 - 8	54.0	78.0	35.0			80
ST12810 - 48 - 48	76	3	- 48	3 - 8	65.0	84.0	40.0			100

ST14110(SAE J516)
NPTF SWIVEL MALE 60° CONE SEAT

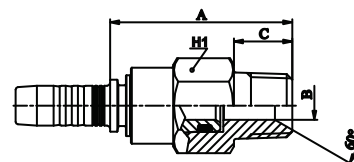

PART. REF.	HOSE BORE			THREAD	DIMENSIONS					
	DN	INCH	SIZE	NPTF	B	A	C			H1
ST14110 - 04 - 02	6	1/4	- 04	1/8 - 27	4.1	44.3	*			19
ST14110 - 04 - 04	6	1/4	- 04	1/4 - 18	4.1	42.8	*			19
ST14110 - 04 - 06	6	1/4	- 04	3/8 - 18	7.0	46.4	14.5			19
ST14110 - 06 - 04	10	3/8	- 06	1/4 - 18	4.1	51.4	19.5			19
ST14110 - 06 - 06	10	3/8	- 06	3/8 - 18	7.0	48.4	19.5			22
ST14110 - 06 - 08	10	3/8	- 06	1/2 - 14	7.0	55.3	27.6			27
ST14110 - 08 - 06	12	1/2	- 08	3/8 - 18	7.0	51.5	14.5			27
ST14110 - 08 - 08	12	1/2	- 08	1/2 - 14	9.5	55.6	27.6			27
ST14110 - 12 - 12	19	3/4	- 12	3/4 - 14	15.0	61.6	27.72			32
ST14110 - 16 - 16	25	1	- 16	1 - 11.5	20.0	69.4	32.85			41

ST14190(SAE J516)
90° NPTF SWIVEL MALE

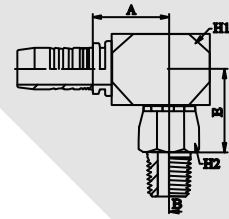

PART. REF.	HOSE BORE			THREAD	DIMENSIONS					
	DN	INCH	SIZE	NPTF	B	A	E		H1	H2
ST14190 - 04 - 04	6	1/4	- 04	1/4 - 18	*	*	*		*	*
ST14190 - 06 - 06	10	3/8	- 06	3/8 - 18	*	*	*		*	*
ST14190 - 08 - 08	12	1/2	- 08	1/2 - 14	*	*	*		*	*
ST14190 - 12 - 12	12	3/4	- 12	3/4 - 14	*	*	*		*	*

ST22812(SAE J516)
NPSM FEMALE 60° CONE SEAT SWIVEL

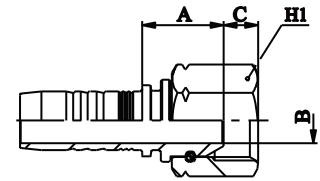

PART. REF.	HOSE BORE			THREAD	DIMENSIONS					
	DN	INCH	SIZE	NPSM	B	A	C			H1
ST22812 - 04 - 04	6	1/4	- 04	1/4 - 18	4.1	19.0	4.2			19
ST22812 - 04 - 06	6	1/4	- 04	3/8 - 18	4.1	18.1	5.5			22
ST22812 - 06 - 06	10	3/8	- 06	3/8 - 18	7.0	20.3	6.5			22
ST22812 - 06 - 08	10	3/8	- 06	1/2 - 14	9.5	23.8	6.5			27
ST22812 - 08 - 08	12	1/2	- 08	1/2 - 14	9.3	22.2	6.5			27
ST22812 - 12 - 12	19	3/4	- 12	3/4 - 14	15.0	25.0	9.0			32
ST22812 - 16 - 16	25	1	- 16	1 - 11.5	20.0	27.8	11.0			28

ST22814(SAE J516)
NPTF FEMALE FIX

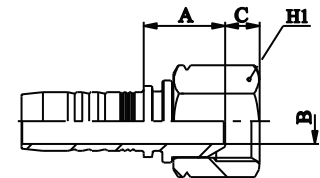

PART. REF.	HOSE BORE			THREAD	DIMENSIONS					
	DN	INCH	SIZE	NPTF	B	A	C			H1
ST22814 - 04 - 02	6	1/4	- 04	1/8 - 27	4.1	13.5	9.0			14
ST22814 - 04 - 04	6	1/4	- 04	1/4 - 18	4.1	16.0	12.0			19
ST22814 - 06 - 04	10	3/8	- 06	1/4 - 18	7.0	16.3	12.0			19
ST22814 - 06 - 06	10	3/8	- 06	3/8 - 18	7.0	18.0	12.0			22
ST22814 - 06 - 08	10	3/8	- 06	1/2 - 14	7.0	16.0	17.0			25
ST22814 - 08 - 08	12	1/2	- 08	1/2 - 14	9.5	18.0	16.0			25
ST22814 - 12 - 12	19	3/4	- 12	3/4 - 14	15.0	23.9	15.1			32
ST22814 - 16 - 16	25	1	- 16	1 - 11.5	20.0	27.2	17.5			41

ST12510
 (SAE J516/ISO 12151-5)
 JIC MALE 37° CONE SEAT

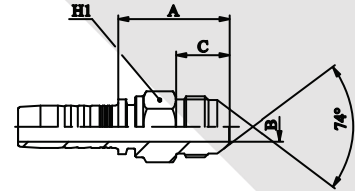

PART. REF.	HOSE BORE			THREAD	DIMENSIONS					
	DN	INCH	SIZE	JIC	B	A	C			H1
ST12510 - 04 - 04	6	1/4	- 04	7/16 - 20	4.1	28.0	14.0			12
ST12510 - 04 - 05	6	1/4	- 04	1/2 - 20	4.1	29.0	14.0			14
ST12510 - 04 - 06	6	1/4	- 04	9/16 - 18	4.1	29.0	14.0			17
ST12510 - 05 - 05	8	5/16	- 05	1/2 - 20	5.5	29.0	14.0			14
ST12510 - 05 - 06	8	5/16	- 05	9/16 - 18	5.5	29.0	14.0			17
ST12510 - 06 - 06	10	3/8	- 06	9/16 - 18	7.0	29.7	14.0			17
ST12510 - 06 - 08	10	3/8	- 06	3/4 - 16	7.0	34.7	16.5			19
ST12510 - 06 - 10	10	3/8	- 06	7/8 - 14	7.0	38.6	19.3			24
ST12510 - 08 - 06	12	1/2	- 08	9/16 - 18	9.5	32.0	14.0			22
ST12510 - 08 - 08	12	1/2	- 08	3/4 - 16	9.5	34.5	16.5			19
ST12510 - 08 - 10	12	1/2	- 08	7/8 - 14	9.5	39.2	19.3			24
ST12510 - 08 - 12	12	1/2	- 08	1.1/16 - 12	9.5	42.9	21.9			27
ST12510 - 10 - 10	16	5/8	- 10	7/8 - 14	12.0	39.2	19.3			24
ST12510 - 10 - 12	16	5/8	- 10	1.1/16 - 12	12.0	42.7	21.9			27
ST12510 - 12 - 10	19	3/4	- 12	7/8 - 14	15.0	41.5	19.3			27
ST12510 - 12 - 12	19	3/4	- 12	1.1/16 - 12	15.0	44.0	21.9			27
ST12510 - 12 - 14	19	3/4	- 12	1.3/16 - 12	15.0	44.5	22.6			32
ST12510 - 12 - 16	19	3/4	- 12	1.5/16 - 12	15.0	47.0	23.1			34
ST12510 - 16 - 12	25	1	- 16	1.1/16 - 12	20.0	44.8	21.9			32
ST12510 - 16 - 16	25	1	- 16	1.5/16 - 12	19.7	48.0	23.1			34
ST12510 - 16 - 20	25	1	- 16	1.5/8 - 12	20.0	52.8	24.3			46
ST12510 - 20 - 20	31	1.1/4	- 20	1.5/8 - 12	25.0	53.5	24.3			46
ST12510 - 20 - 24	31	1.1/4	- 20	1.7/8 - 12	25.0	60.5	27.5			50
ST12510 - 24 - 24	38	1.1/2	- 24	1.7/8 - 12	32.0	60.5	27.5			50
ST12510 - 32 - 32	51	2	- 32	2.1/2 - 12	42.0	71.8	33.9			65

ST22541
 (SAE J516/ISO 12151-5)
 45° JIC FEMALE 37° CONE SEAT
 CRIMP BACK

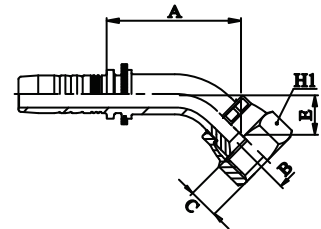

PART. REF.	HOSE BORE			THREADS	DIMENSIONS					
	DN	INCH	SIZE	JIC	B	A	C	E	H1	
ST22541 - 04 - 04	6	1/4	- 04	7/16 - 20	4.1	35.5	9.5	14.5	14	
ST22541 - 04 - 05	6	1/4	- 04	1/2 - 20	*	*	*	*	*	
ST22541 - 04 - 06	6	1/4	- 04	9/16 - 18	*	*	*	*	*	
ST22541 - 06 - 06	10	3/8	- 06	9/16 - 18	7.0	42.0	9.5	16.5	17	
ST22541 - 06 - 08	10	3/8	- 06	3/4 - 16	*	*	*	*	*	
ST22541 - 08 - 08	12	1/2	- 08	3/4 - 16	9.5	52.0	11.0	20.0	22	
ST22541 - 08 - 10	12	1/2	- 08	7/8 - 14	9.5	49.5	12.0	17.0	25	
ST22541 - 10 - 10	16	5/8	- 10	7/8 - 14	*	*	*	*	*	
ST22541 - 12 - 12	19	3/4	- 12	1.1/16 - 12	15.0	70.0	14.5	27.5	32	
ST22541 - 12 - 16	19	3/4	- 12	1.5/16 - 12	*	*	*	*	*	
ST22541 - 16 - 16	25	1	- 16	1.5/16 - 12	*	*	*	*	*	
ST22541 - 20 - 20	31	1.1/4	- 20	1.5/8 - 12	*	*	*	*	*	

ST22542

(SAE J516/ISO 12151-5)

45° JIC FEMALE 37° CONE SEAT
THRUST WIRE

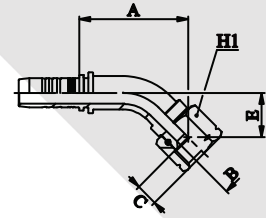

PART. REF.	HOSE BORE			THREAD	DIMENSIONS				
	DN	INCH	SIZE	JIC	B	A	C	E	H1
ST22542 - 03 - 04	5	3/16	- 03	7/16 - 20	3.1	35.0	9.0	14.5	17
ST22542 - 04 - 04	6	1/4	- 04	7/16 - 20	4.1	35.5	9.0	14.5	17
ST22542 - 04 - 05	6	1/4	- 04	1/2 - 20	4.1	35.7	9.5	14.5	17
ST22542 - 04 - 06	6	1/4	- 04	9/16 - 18	4.1	35.5	9.5	14.0	19
ST22542 - 05 - 05	8	5/16	- 05	1/2 - 20	5.5	37.5	9.5	14.5	17
ST22542 - 05 - 06	8	5/16	- 05	9/16 - 18	5.5	38.0	9.5	14.5	19
ST22542 - 06 - 06	10	3/8	- 06	9/16 - 18	7.0	42.0	9.5	16.5	19
ST22542 - 06 - 08	10	3/8	- 06	3/4 - 16	9.9	45.8	11.0	14.0	22
ST22542 - 06 - 10	10	3/8	- 06	7/8 - 14	7.0	42.5	13.0	15.5	27
ST22542 - 08 - 08	12	1/2	- 08	3/4 - 16	9.5	52.0	11.0	20.0	22
ST22542 - 08 - 10	12	1/2	- 08	7/8 - 14	9.5	49.5	13.0	17.0	27
ST22542 - 08 - 12	12	1/2	- 08	1.1/16 - 12	9.5	50.0	14.4	17.0	32
ST22542 - 10 - 10	16	5/8	- 10	7/8 - 14	12.0	62.0	25.5	25.5	27
ST22542 - 10 - 12	16	5/8	- 10	1.1/16 - 12	12.0	60.0	14.4	24.0	32
ST22542 - 12 - 12	19	3/4	- 12	1.1/16 - 12	15.0	70.0	14.4	27.5	32
ST22542 - 12 - 14	19	3/4	- 12	1.3/16 - 12	15.0	70.6	15.8	28.2	35.5
ST22542 - 12 - 16	19	3/4	- 12	1.5/16 - 12	15.0	68.4	15.6	27.5	38
ST22542 - 16 - 12	25	1	- 16	1.1/16 - 12	20.0	72.5	14.4	27.5	32
ST22542 - 16 - 16	25	1	- 16	1.5/16 - 12	20.0	86.0	15.6	32.0	38
ST22542 - 16 - 20	25	1	- 16	1.5/8 - 12	20.0	90.0	16.0	36.0	50
ST22542 - 20 - 20	31	1.1/4	- 20	1.5/8 - 12	25.0	103.5	16.0	41.5	50
ST22542 - 20 - 24	31	1.1/4	- 20	1.7/8 - 12	32.0	106.5	18.8	44.5	60
ST22542 - 24 - 24	38	1.1/2	- 24	1.7/8 - 12	32.0	119.0	18.3	46.5	60
ST22542 - 32 - 32	51	2	- 32	2.1/2 - 12	44.0	163.0	24.0	68.0	75

ST22582

(SAE J516/ISO 12151-5)

90° JIC FEMALE COMPACT ELBOW 37° CONE SEAT
THRUST WIRE

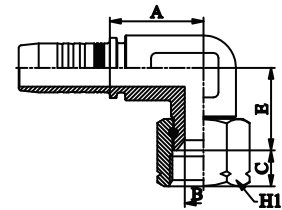

PART. REF.	HOSE BORE			THREAD	DIMENSIONS				
	DN	INCH	SIZE	JIC	B	A	C	E	H1
ST22582 - 04 - 04	6	1/4	- 04	7/16 - 20	4.1	20.0	9.0	20.5	17
ST22582 - 04 - 06	6	1/4	- 04	9/16 - 18	4.1	18.5	9.5	21.5	19
ST22582 - 06 - 06	10	3/8	- 06	9/16 - 18	7.0	23.1	9.5	24.0	19
ST22582 - 06 - 08	10	3/8	- 06	3/4 - 16	7.0	26.6	11.0	28.0	22
ST22582 - 08 - 08	12	1/2	- 08	3/4 - 16	9.5	23.0	11.0	28.0	22
ST22582 - 08 - 10	12	1/2	- 08	7/8 - 14	9.5	23.0	13.0	29.0	27
ST22582 - 12 - 12	19	3/4	- 12	1.1/16 - 12	15.0	28.0	14.4	33.0	32
ST22582 - 16 - 16	20	1	- 16	1.5/16 - 12	20.0	30.0	15.6	40.0	38

ST22591

(SAE J516/ISO 12151-5)

90° JIC FEMALE 37° CONE SEAT
CRIMP BACK

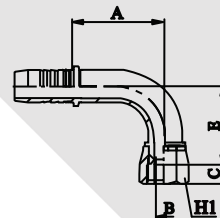

PART. REF.	HOSE BORE			THREAD	DIMENSIONS					
	DN	INCH	SIZE		JIC	B	A	C	E	H1
ST22591 - 04 - 04	6	1/4	- 04	7/16 - 20	4.1	30.4	9.0	26.0		14.3
ST22591 - 04 - 05	6	1/4	- 04	1/2 - 20	*	*	*	*		*
ST22591 - 04 - 06	6	1/4	- 04	9/16 - 18	4.1	29.5	9.5	28.0		17.5
ST22591 - 05 - 06	8	5/16	- 05	9/16 - 18	*	*	*	*		*
ST22591 - 06 - 06	10	3/8	- 06	9/16 - 18	7.0	35.5	10.0	32.5		17.5
ST22591 - 06 - 08	10	3/8	- 06	3/4 - 16	*	*	*	*		*
ST22591 - 08 - 08	12	1/2	- 08	3/4 - 16	9.5	46.5	11.0	42.0		22.2
ST22591 - 08 - 10	12	1/2	- 08	7/8 - 14	9.5	45.0	12.0	36.0		25.4
ST22591 - 08 - 12	12	1/2	- 08	1.1/16 - 12	*	*	*	*		*
ST22591 - 10 - 10	16	5/8	- 10	7/8 - 14	12.0	53.5	12.0	52.5		25.4
ST22591 - 10 - 12	16	5/8	- 10	1.1/16 - 12	*	*	*	*		*
ST22591 - 12 - 12	19	3/4	- 12	1.1/16 - 12	15.0	63.0	14.5	54.0		32
ST22591 - 12 - 16	19	3/4	- 12	1.5/16 - 12	*	*	*	*		*
ST22591 - 16 - 12	25	1	- 16	1.1/16 - 12	*	*	*	*		*
ST22591 - 16 - 16	25	1	- 16	1.5/16 - 12	20.0	77.0	15.7	67.0		38.1
ST22591 - 16 - 20	25	1	- 16	1.5/8 - 12	*	*	*	*		*
ST22591 - 20 - 20	31	1.1/4	- 20	1.5/8 - 12	*	*	*	*		*

ST22592

(SAE J516/ISO 12151-5)

90° JIC FEMALE 37° CONE SEAT
THRUST WIRE

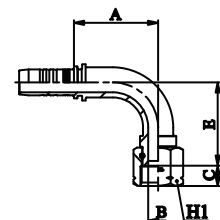

PART. REF.	HOSE BORE			THREAD	DIMENSIONS					
	DN	INCH	SIZE		JIC	B	A	C	E	H1
ST22592 - 03 - 04	5	3/16	- 03	7/16 - 20	3.1	26.0	9.0	23.5		17
ST22592 - 04 - 04	6	1/4	- 04	7/16 - 20	4.1	28.5	9.0	27.0		17
ST22592 - 04 - 05	6	1/4	- 04	1/2 - 20	4.1	28.5	9.5	27.5		17
ST22592 - 04 - 06	6	1/4	- 04	9/16 - 18	4.1	29.5	9.5	28.0		19
ST22592 - 04 - 08	6	1/4	- 04	3/4 - 16	4.1	29.3	11.0	30.5		22
ST22592 - 05 - 05	8	5/16	- 05	1/2 - 20	5.5	29.5	9.2	27.5		17
ST22592 - 05 - 06	8	5/16	- 05	9/16 - 18	5.5	31.0	9.5	28.5		19
ST22592 - 06 - 06	10	3/8	- 06	9/16 - 18	7.0	35.5	9.5	32.5		19
ST22592 - 06 - 08	10	3/8	- 06	3/4 - 16	7.0	36.5	11.0	29.5		22
ST22592 - 06 - 10	10	3/8	- 06	7/8 - 14	9.3	36.5	12.4	31.5		27
ST22592 - 08 - 06	12	1/2	- 08	9/16 - 18	9.5	36.5	9.5	33.0		19
ST22592 - 08 - 08	12	1/2	- 08	3/4 - 16	9.5	44.0	11.0	41.0		22
ST22592 - 08 - 10	12	1/2	- 08	7/8 - 14	9.5	45.0	13.0	36.0		27
ST22592 - 08 - 12	12	1/2	- 08	1.1/16 - 12	9.5	45.0	14.4	41.0		32
ST22592 - 10 - 10	16	5/8	- 10	7/8 - 14	12.0	53.5	13.0	52.5		27
ST22592 - 10 - 12	16	5/8	- 10	1.1/16 - 12	12.0	51.5	14.4	50.0		32
ST22592 - 12 - 10	19	1/2	- 12	7/8 - 14	15.0	55.0	13.0	52.5		27
ST22592 - 12 - 12	19	1/2	- 12	1.1/16 - 12	15.0	62.0	14.4	58.0		32
ST22592 - 12 - 14	19	1/2	- 12	1.3/16 - 12	15.0	62.0	15.0	58.0		36
ST22592 - 12 - 16	19	1/2	- 12	1.5/16 - 12	15.0	62.0	15.6	57.5		38
ST22592 - 16 - 16	25	1	- 16	1.5/16 - 12	20.0	77.0	15.6	67.0		38
ST22592 - 16 - 20	25	1	- 16	1.5/8 - 12	20.0	77.5	16.0	74.5		50
ST22592 - 20 - 20	31	1.1/4	- 20	1.5/8 - 12	25.0	90.5	16.0	86.5		50
ST22592 - 20 - 24	31	1.1/4	- 20	1.7/8 - 12	32.0	90.5	18.8	91.0		60
ST22592 - 24 - 24	38	1.1/2	- 24	1.7/8 - 12	32.0	108.0	18.3	100.5		60
ST22592 - 32 - 32	51	2	- 32	2.1/2 - 12	42.0	142.0	23.5	137.0		75

ST22711

(SAE J516/J514)[CRIMP BACK]

JIC FEMALE 37° CONE SEAT DOUBLE HEXAGON
CRIMP BACK

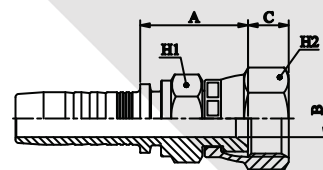

PART. REF.	HOSE BORE			THREAD	DIMENSIONS					
	DN	INCH	SIZE	JIC	B	A	C	H1	H2	
ST22711 - 03 - 04	5	3/16	- 03	7/16 - 20	*	*	*	*	*	
ST22711 - 04 - 04	6	1/4	- 04	7/16 - 20	4.1	20.5	9.0	14	14.3	
ST22711 - 04 - 05	6	1/4	- 04	1/2 - 20	*	*	*	*	*	
ST22711 - 04 - 06	6	1/4	- 04	9/16 - 18	4.1	21.6	9.5	14	17.5	
ST22711 - 06 - 06	10	3/8	- 06	9/16 - 18	7.0	23.0	10.0	17	17.5	
ST22711 - 06 - 08	10	3/8	- 06	3/4 - 16	*	*	*	*	*	
ST22711 - 06 - 10	10	3/8	- 06	7/8 - 14	*	*	*	*	*	
ST22711 - 08 - 06	12	1/2	- 08	9/16 - 18	7.0	25.1	11.0	17	22.2	
ST22711 - 08 - 08	12	1/2	- 08	3/4 - 16	9.5	27.7	11.0	19	22.2	
ST22711 - 08 - 10	12	1/2	- 08	7/8 - 14	9.5	28.7	11.0	22	25.4	
ST22711 - 08 - 12	12	1/2	- 08	1.1/16 - 12	9.5	29.5	14.2	27	32	
ST22711 - 10 - 08	16	3/8	- 10	3/4 - 16	12.0	29.5	10.0	22	22	
ST22711 - 10 - 10	16	3/8	- 10	7/8 - 14	12.0	29.5	12.0	22	25.4	
ST22711 - 10 - 12	16	3/8	- 10	1.1/16 - 12	15.0	29.0	14.1	27	32	
ST22711 - 12 - 08	19	3/4	- 12	3/4 - 16	9.3	29.5	10.7	27	22	
ST22711 - 12 - 10	19	3/4	- 12	7/8 - 14	12.5	30.5	12.5	27	25	
ST22711 - 12 - 12	19	3/4	- 12	1.1/16 - 12	15.0	31.8	14.5	27	32	
ST22711 - 12 - 16	19	3/4	- 12	1.5/16 - 12	19.8	34.5	15.3	32	38	
ST22711 - 14 - 16	22	7/8	- 14	1.5/16 - 12	*	*	*	*	*	
ST22711 - 16 - 12	25	1	- 16	1.1/16 - 12	19.0	33.0	13.4	32	32	
ST22711 - 16 - 16	25	1	- 16	1.5/16 - 12	19.7	32.9	16.0	32	38.1	
ST22711 - 16 - 20	25	1	- 16	1.5/8 - 12	*	*	*	*	*	
ST22711 - 18 - 20	29	1.1/8	- 18	1.5/8 - 12	*	*	*	*	*	
ST22711 - 20 - 20	31	1.1/4	- 20	1.5/8 - 12	25.0	42.0	16.0	41	50	
ST22711 - 22 - 24	35	1.3/8	- 22	1.7/8 - 12	*	*	*	*	*	
ST22711 - 29 - 32	46	1.13/16	- 29	2.1/2 - 12	*	*	*	*	*	

ST22712

(SAE J516/ISO 12151-5)

JIC FEMALE 37° CONE SEAT DOUBLE HEXAGON
THRUST WIRE

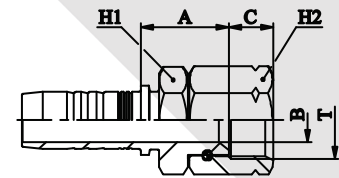

PART. REF.	HOSE BORE			THREAD	DIMENSIONS					
	DN	INCH	SIZE	JIC	B	A	C		H1	H2
ST22712 - 03 - 04	5	3/16	- 03	7/16 - 20	3.1	20.8	9.0		12	17
ST22712 - 04 - 04	6	1/4	- 04	7/16 - 20	4.1	21.0	9.0		12	17
ST22712 - 04 - 05	6	1/4	- 04	1/2 - 20	4.1	21.5	9.5		12	17
ST22712 - 04 - 06	6	1/4	- 04	9/16 - 18	7.0	23.8	9.5		14	19
ST22712 - 05 - 05	8	5/16	- 05	1/2 - 20	5.5	21.5	9.5		14	17
ST22712 - 05 - 06	8	5/16	- 05	9/16 - 18	5.5	24.9	9.5		14	19
ST22712 - 06 - 04	10	3/8	- 06	7/16 - 20	7.0	23.8	9.0		17	17
ST22712 - 06 - 05	10	3/8	- 06	1/2 - 20	7.0	23.8	9.5		17	17
ST22712 - 06 - 06	10	3/8	- 06	9/16 - 18	7.0	25.3	9.5		17	19
ST22712 - 06 - 08	10	3/8	- 06	3/4 - 16	7.0	25.3	11.0		19	22
ST22712 - 06 - 10	10	3/8	- 06	7/8 - 14	7.0	25.8	13.0		22	27
ST22712 - 08 - 06	12	1/2	- 08	9/16 - 18	9.5	26.2	9.5		19	19
ST22712 - 08 - 08	12	1/2	- 08	3/4 - 16	9.5	26.2	11.0		19	22
ST22712 - 08 - 10	12	1/2	- 08	7/8 - 14	9.5	26.7	13.0		22	27
ST22712 - 08 - 12	12	1/2	- 08	1.1/16 - 12	9.5	30.5	14.4		27	32
ST22712 - 10 - 08	16	5/8	- 10	3/4 - 16	12.0	27.5	11.0		22	22
ST22712 - 10 - 10	16	5/8	- 10	7/8 - 14	12.0	29	13.0		22	27
ST22712 - 10 - 12	16	5/8	- 10	1.1/16 - 12	12.0	31.6	14.4		27	32
ST22712 - 12 - 08	19	3/4	- 12	3/4 - 16	15.0	28.3	11.0		27	22
ST22712 - 12 - 10	19	3/4	- 12	7/8 - 14	15.0	27.0	13.0		27	27
ST22712 - 12 - 12	19	3/4	- 12	1.1/16 - 12	15.0	31.5	14.4		24	32
ST22712 - 12 - 14	19	3/4	- 12	1.3/16 - 12	15.0	34.0	15.0		30	36
ST22712 - 12 - 16	19	3/4	- 12	1.5/16 - 12	15.0	32.5	15.6		32	38
ST22712 - 16 - 12	25	1	- 16	1.1/16 - 12	20.0	34.3	14.4		32	32
ST22712 - 16 - 16	25	1	- 16	1.5/16 - 12	20.0	34.7	15.6		32	38
ST22712 - 16 - 20	25	1	- 16	1.5/8 - 12	20.0	37.7	16.0		41	50
ST22712 - 20 - 16	31	1.1/4	- 20	1.5/16 - 12	25.0	36	15.6		41	38
ST22712 - 20 - 20	31	1.1/4	- 20	1.5/8 - 12	25.0	41.0	16.0		41	50
ST22712 - 24 - 24	38	1.1/2	- 24	1.7/8 - 12	32.0	43.3	18.3		50	60
ST22712 - 32 - 32	51	2	- 32	2.1/2 - 12	42.0	55.5	23.5		65	75

ST24792

(SAE J516/ISO 12151-5)

90° JIC FEMALE LONG DROP ELBOW 37° CONE SEAT
THRUST WIRE

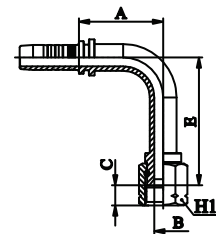

PART. REF.	HOSE BORE			THREAD	DIMENSIONS					
	DN	INCH	SIZE	JIC	B	A	C	E	H1	
ST24792 - 04 - 04	6	3/16	- 04	7/16 - 20	4.1	28.5	9.0	45.0	17	
ST24792 - 04 - 06	6	3/16	- 06	9/16 - 18	4.1	29.5	9.5	55.5	19	
ST24792 - 06 - 06	10	3/8	- 06	9/16 - 18	7.0	35.5	9.5	55.0	19	
ST24792 - 06 - 08	10	3/8	- 06	3/4 - 16	7.0	61.5	11.0	61.5	22	
ST24792 - 08 - 08	12	1/2	- 08	3/4 - 16	9.5	40.6	11.0	61.5	22	
ST24792 - 08 - 10	12	1/2	- 08	7/8 - 14	9.5	45.0	13.0	65.0	27	
ST24792 - 10 - 10	16	5/8	- 10	7/8 - 14	12.0	53.5	13.0	65.5	27	
ST24792 - 12 - 12	19	3/4	- 12	1.1/16 - 12	15.0	62.0	14.4	94.5	32	
ST24792 - 16 - 16	25	1	- 16	1.5/16 - 12	20.0	77.0	15.6	110.0	38	
ST24792 - 20 - 20	31	1.1/4	- 20	1.5/8 - 12	25.0	90.5	16.0	129.0	50	

ST13010

(SAE J516/ISO 11926)

SAE MALE O’RING BOSS TYPE

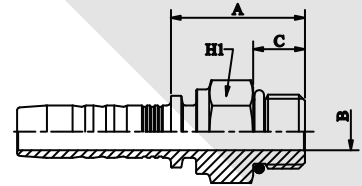

PART. REF.	HOSE BORE			THREAD	DIMENSIONS					
	DN	INCH	SIZE	ORB	B	A	C			H1
ST13010 - 04 - 04	6	1/4	- 04	7/16 - 20	4.1	23	9.1			14
ST13010 - 04 - 05	6	1/4	- 04	1/2 - 20	4.1	23	9.1			17
ST13010 - 04 - 06	6	1/4	- 04	9/16 - 18	4.1	24.5	10.0			17
ST13010 - 04 - 08	6	1/4	- 04	3/4 - 16	10.0	28.3	11.1			22
ST13010 - 06 - 06	10	3/8	- 06	9/16 - 18	7.0	25.6	10.0			17
ST13010 - 06 - 08	10	3/8	- 06	3/4 - 16	7.0	28.6	11.1			22
ST13010 - 06 - 10	10	3/8	- 06	7/8 - 14	7.0	31.5	12.7			25
ST13010 - 08 - 08	12	1/2	- 08	3/4 - 16	9.5	28.9	11.1			22
ST13010 - 08 - 10	12	1/2	- 08	7/8 - 14	9.5	31.9	12.7			25
ST13010 - 08 - 12	12	1/2	- 08	1.1/16 - 12	9.5	38.5	15.1			32
ST13010 - 10 - 10	16	5/8	- 10	7/8 - 14	12.0	32.0	12.7			25
ST13010 - 10 - 12	16	5/8	- 10	1.1/16 - 12	12.0	37.7	15.1			32
ST13010 - 12 - 10	19	3/4	- 12	7/8 - 14	12.0	37.7	12.7			32
ST13010 - 12 - 12	19	3/4	- 12	1.1/16 - 12	15.0	39.5	15.1			32
ST13010 - 12 - 16	19	3/4	- 12	1.5/16 - 12	15.0	40.1	15.1			38
ST13010 - 16 - 16	25	1	- 16	1.5/16 - 12	20.0	41.0	15.1			38

ST14310

(SAE J516/ISO 11926)

SAE SWIVEL MALE O’RING BOSS TYPE

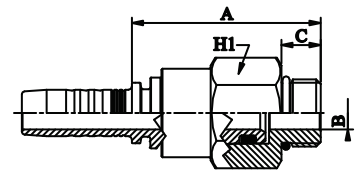

PART. REF.	HOSE BORE			THREAD	DIMENSIONS					
	DN	INCH	SIZE	ORB	B	A	C			H2
ST14310 - 04 - 04	6	1/4	- 04	7/16 - 20	4.1	38.8				19
ST14310 - 04 - 06	6	1/4	- 04	9/16 - 18	7.0	44.0				22
ST14310 - 06 - 06	10	3/8	- 06	9/16 - 18	7.0	44.4				22
ST14310 - 06 - 08	10	3/8	- 06	3/4 - 16	*	*				*
ST14310 - 08 - 08	12	1/2	- 08	3/4 - 16	9.5	50.1				27
ST14310 - 08 - 10	12	1/2	- 08	7/8 - 14	9.5	52.8				27
ST14310 - 08 - 12	12	1/2	- 08	1.1/16 - 12	9.5	61.2				32
ST14310 - 10 - 10	16	5/8	- 10	7/8 - 14	12.0	55.8				27
ST14310 - 12 - 12	19	3/4	- 12	1.1/16 - 12	*	*				*

ST14390

(SAE J516/ISO 11926)

90° SWIVEL MALE O’RING BOSS TYPE

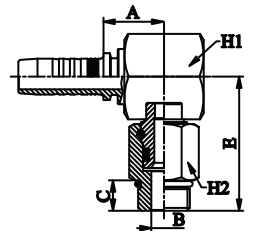

PART. REF.	HOSE BORE			THREAD	DIMENSIONS					
	DN	INCH	SIZE	ORB	B	A	C	E	H1	H2
ST14390 - 06 - 06	10	3/8	- 06	9/16 - 18	7.0	22.8	15.5	46.5	22	22
ST14390 - 06 - 08	10	3/8	- 06	3/4 - 16	7.0	22.8	22.1	51.1	22	27
ST14390 - 08 - 08	12	1/2	- 08	3/4 - 16	9.5	23.0	22.1	51.1	22	27
ST14390 - 08 - 10	12	1/2	- 08	7/8 - 14	9.5	23.0	24.8	53.8	22	27
ST14390 - 10 - 10	16	5/8	- 10	7/8 - 14	12.0	28.0	19.1	52.6	27	27
ST14390 - 12 - 12	19	3/4	- 12	1.1/16 - 12	15.0	30.5	26.2	66.7	32	32

ST12410

(SAE J516/ISO 12151-1)
MALE ORFS

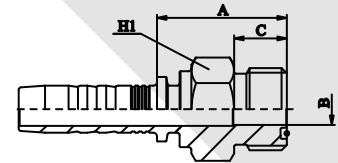

PART. REF.	HOSE BORE			THREAD	DIMENSIONS				
	DN	INCH	SIZE	ORFS	B	A	C		H1
ST12410 - 04 - 04	6	1/4	- 04	9/16 - 18	4.1	24.0	10.0		17
ST12410 - 04 - 06	6	1/4	- 04	11/16 - 16	4.1	26.6	11.0		19
ST12410 - 06 - 06	10	3/8	- 06	11/16 - 16	7.0	27.6	11.0		19
ST12410 - 06 - 08	10	3/8	- 06	13/16 - 16	7.0	30.0	13.0		22
ST12410 - 06 - 10	10	3/8	- 06	1 - 14	*	*	*		*
ST12410 - 08 - 08	12	1/2	- 08	13/16 - 16	9.5	30.6	13.0		22
ST12410 - 08 - 10	12	1/2	- 08	1 - 14	9.5	35.0	15.5		27
ST12410 - 10 - 10	16	25	- 10	1 - 14	12.0	34.7	15.5		27
ST12410 - 10 - 12	16	25	- 10	1.3/16 - 12	12.0	37.5	17.0		32
ST12410 - 12 - 12	19	3/4	- 12	1.3/16 - 12	15.0	39.0	17.0		32
ST12410 - 12 - 16	19	3/4	- 12	1.7/16 - 12	15.0	40.5	17.5		41
ST12410 - 16 - 16	25	1	- 16	1.7/16 - 12	20.0	41.8	17.5		41
ST12410 - 20 - 20	31	1.1/4	- 20	1.11/16 - 12	25.0	46.3	17.5		46
ST12410 - 24 - 24	38	1.1/2	- 24	2 - 12	32.0	48.6	17.5		55

ST22411/ST22413

(SAE J516/ISO 12151-1)
ORFS FEMALE
SLIP-ON NUT

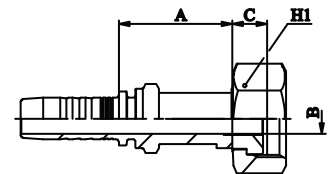

PART. REF.	HOSE BORE			THREAD	DIMENSIONS				
	DN	INCH	SIZE	ORFS	B	A	C		H1
ST22413 - 03 - 04	5	3/16	- 03	9/16 - 18	3.1	26.6	8.0		17
ST22413 - 04 - 04	6	1/4	- 04	9/16 - 18	4.1	27.5	8.0		17
ST22413 - 04 - 06	6	1/4	- 04	11/16 - 16	4.1	30.0	10.5		22
ST22413 - 05 - 06	8	5/16	- 05	11/16 - 16	7.0	29.6	10.5		22
ST22411 - 06 - 04	10	5/16	- 06	9/16 - 18	7.0	29.0	8.5		17
ST22413 - 06 - 06	10	5/16	- 06	11/16 - 16	7.0	31.1	10.5		22
ST22413 - 06 - 08	10	5/16	- 06	13/16 - 16	7.0	35.6	10.0		24
ST22411 - 08 - 06	12	1/2	- 08	11/16 - 16	9.5	31.9	10.0		22
ST22413 - 08 - 08	12	1/2	- 08	13/16 - 16	9.5	35.9	10.0		24
ST22413 - 08 - 10	12	1/2	- 08	1 - 14	9.5	38.4	12.5		30
ST22413 - 08 - 12	12	1/2	- 08	1.3/16 - 12	9.5	41.9	14.5		36
ST22411 - 10 - 08	16	5/8	- 10	13/16 - 16	12.0	38.4	11.0		24
ST22413 - 10 - 10	16	5/8	- 10	1 - 14	12.0	38.7	12.5		30
ST22413 - 10 - 12	16	5/8	- 10	1.3/16 - 12	12.0	42.0	13.5		36
ST22411 - 12 - 10	19	3/4	- 12	1 - 14	15.0	41.0	13.0		30
ST22413 - 12 - 12	19	3/4	- 12	1.3/16 - 12	15.0	43.5	13.5		36
ST22413 - 12 - 16	19	3/4	- 12	1.7/16 - 12	15.0	45.5	13.5		41
ST22411 - 16 - 12	25	1	- 16	1.3/16 - 12	20.0	45.8	14.5		36
ST22413 - 16 - 16	25	1	- 16	1.7/16 - 12	19.7	46.3	13.5		41
ST22413 - 16 - 20	25	1	- 16	1.11/16 - 12	20.0	49.5	14.0		50
ST22413 - 20 - 20	31	1.1/4	- 20	1.11/16 - 12	25.0	49.0	13.5		50
ST22413 - 24 - 24	38	1.1/2	- 24	2 - 12	32.0	54.0	13.5		60

ST22441/ST22443

(SAE J516/ISO 12151-1)

45° MALE ORFS

SLIP-ON NUT

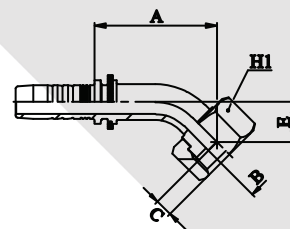

PART. REF.	HOSE BORE			THREAD	DIMENSIONS					
	DN	INCH	SIZE	ORFS	B	A	C	E	H1	
ST22443 - 03 - 04	5	3/16	- 03	9/16 - 18	3.1	32.3	8.0	10.5	17	
ST22443 - 04 - 04	6	1/4	- 04	9/16 - 18	4.1	31.0	10.5	10.5	17	
ST22443 - 04 - 06	6	1/4	- 04	11/16 - 16	4.1	31.0	10.5	10.5	22	
ST22443 - 05 - 06	8	5/16	- 05	11/16 - 16	5.5	31.9	10.5	10.5	22	
ST22443 - 06 - 06	10	3/8	- 06	11/16 - 16	7.0	32.5	10.5	11.0	22	
ST22441 - 06 - 04	10	3/8	- 06	9/16 - 18	*	*	*	*	*	
ST22443 - 06 - 08	10	3/8	- 06	13/16 - 16	7.0	34.0	10.0	12.5	24	
ST22441 - 08 - 06	12	1/2	- 08	11/16 - 16	9.5	40.0	9.0	11.0	22	
ST22443 - 08 - 08	12	1/2	- 08	13/16 - 16	9.5	42.0	10.0	13.0	24	
ST22443 - 08 - 10	12	1/2	- 08	1 - 14	9.5	42.0	12.5	13.5	30	
ST22443 - 08 - 12	12	1/2	- 08	1.3/16 - 12	9.5	50.0	13.5	18.5	36	
ST22443 - 10 - 10	16	5/8	- 10	1 - 14	12.0	49.0	12.5	16.0	30	
ST22443 - 10 - 12	16	5/8	- 10	1.3/16 - 12	12.0	51.5	13.5	18.5	36	
ST22441 - 12 - 10	19	3/4	- 12	1 - 14	15.0	57.5	13.5	16.5	30	
ST22443 - 12 - 12	19	3/4	- 12	1.3/16 - 12	15.0	60.5	13.5	21.5	36	
ST22443 - 12 - 16	19	3/4	- 12	1.7/16 - 12	15.0	64.5	13.5	21.0	41	
ST22443 - 16 - 16	25	1	- 16	1.7/16 - 12	19.7	72.0	13.5	23.5	41	
ST22443 - 16 - 20	25	1	- 16	1.11/16 - 12	20.0	74.0	13.5	25.5	50	
ST22443 - 20 - 20	31	1.1/4	- 20	1.11/16 - 12	25.0	82.0	13.5	27.0	50	
ST22443 - 24 - 24	38	1.1/2	- 24	2 - 12	32.0	98.0	13.5	31.5	60	

ST22491/ST22493

(SAE J516/ISO 12151-1)

90° ORFS FEMALE

SLIP-ON NUT

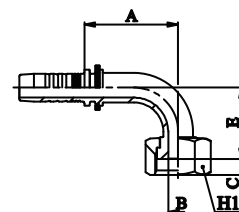

PART. REF.	HOSE BORE			THREAD	DIMENSIONS					
	DN	INCH	SIZE	ORFS	B	A	C	E	H1	
ST22493 - 03 - 04	5	3/16	- 03	9/16 - 18	3.1	28.8	8.0	22.0	17	
ST22493 - 04 - 04	6	1/4	- 04	9/16 - 18	4.1	27.5	8.0	22.0	17	
ST22493 - 04 - 06	6	1/4	- 04	11/16 - 16	4.1	27.5	10.5	22.0	22	
ST22493 - 05 - 06	8	5/16	- 05	11/16 - 16	5.5	28.6	10.5	23.0	22	
ST22491 - 06 - 04	10	3/8	- 06	9/16 - 18	7.0	30.0	8.0	23.0	17	
ST22493 - 06 - 06	10	3/8	- 06	11/16 - 16	7.0	30.0	10.5	24.0	22	
ST22493 - 06 - 08	10	3/8	- 06	13/16 - 16	7.0	30.0	10.0	26.5	24	
ST22491 - 08 - 06	12	1/2	- 08	11/16 - 16	9.5	35.0	10.0	24.5	22	
ST22493 - 08 - 08	12	1/2	- 08	13/16 - 16	9.5	40.5	10.0	30.0	24	
ST22493 - 08 - 10	12	1/2	- 08	1 - 14	9.5	40.5	12.5	30.0	30	
ST22493 - 08 - 12	12	1/2	- 08	1.3/16 - 12	9.5	48.0	13.5	37.5	36	
ST22493 - 10 - 10	16	5/8	- 10	1 - 14	12.0	48.0	12.5	37.5	30	
ST22493 - 10 - 12	16	5/8	- 10	1.3/16 - 12	12.0	48.0	13.5	41.0	36	
ST22491 - 12 - 10	19	3/4	- 12	1 - 14	15.0	54.0	13.5	38.0	30	
ST22493 - 12 - 12	19	3/4	- 12	1.3/16 - 12	15.0	56.5	13.5	48.0	36	
ST22493 - 12 - 16	19	3/4	- 12	1.7/16 - 12	15.0	62.5	13.5	47.5	41	
ST22491 - 16 - 12	25	1	- 16	1.3/16 - 12	20.0	62.5	13.5	48.0	36	
ST22493 - 16 - 16	25	1	- 16	1.7/16 - 12	19.7	71.5	13.5	56.0	41	
ST22493 - 16 - 20	25	1	- 16	1.11/16 - 12	20.0	71.5	13.5	58.5	50	
ST22493 - 20 - 20	31	31	- 20	1.11/16 - 12	25.0	83.0	13.5	66.0	50	
ST22493 - 24 - 24	38	38	- 24	2 - 12	32.0	102.0	13.5	79.5	60	

ST24493

(SAE J516/ISO 12151-1)

90° FEMALE ORFS LONG DROP

SLIP-ON NUT

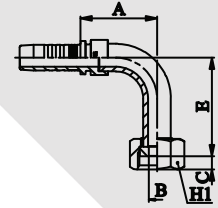

PART. REF.	HOSE BORE			THREAD	DIMENSIONS					
	DN	INCH	SIZE	ORFS	B	A	C	E		H1
ST24493 - 04 - 04	6	1/4	- 04	9/16 - 18	4.1	27.5	8.0	45.5		17
ST24493 - 04 - 06	6	1/4	- 04	11/16 - 16	7.0	24.5	9.5	53.5		22
ST24493 - 06 - 06	10	3/8	- 06	11/16 - 16	7.0	31.5	9.5	53.5		22
ST24493 - 06 - 08	10	3/8	- 06	13/16 - 16	7.0	35.7	10.0	53.5		24
ST24493 - 08 - 08	12	3/4	- 08	13/16 - 16	9.5	40.5	10.0	63.5		24
ST24493 - 08 - 10	12	3/4	- 08	1 - 14	9.5	44.5	12.5	64.0		30
ST24493 - 10 - 10	16	5/8	- 10	1 - 14	12.0	48.0	12.5	69.0		30
ST24493 - 10 - 12	16	5/8	- 10	1.3/6 - 12	12.0	54.5	13.5	73.0		36
ST24493 - 12 - 12	19	3/4	- 12	1.3/16 - 12	15.0	56.5	13.5	96.0		36
ST24493 - 16 - 16	25	1	- 16	1.7/16 - 12	19.7	71.5	13.5	113.5		41
ST24493 - 20 - 20	31	1.1/4	- 20	1.11/16 - 12	25.0	92.0	13.5	129.0		50
ST24493 - 24 - 24	38	1.1/2	- 24	2 - 12	32.0	102.0	13.5	141.0		60

ST23311

(SAE J516/ISO 12151-3)
STRAIGHT SAE FLANGE 3000PSI
CODE 61

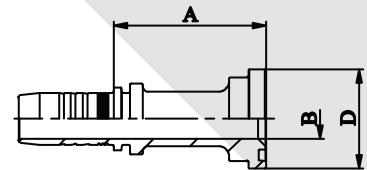

PART. REF.	HOSE BORE			FLANGE CODE 61	DIMENSIONS					
	DN	INCH	SIZE		B	A	D			
ST23311 - 08 - 08	12	1/2	- 08	1/2	9.5	50.9	30.2			
ST23311 - 08 - 12	12	1/2	- 08	3/4	9.5	57.7	38.1			
ST23311 - 10 - 12	16	5/8	- 08	3/4	15.0	65.7	38.1			
ST23311 - 12 - 12	19	3/4	- 12	3/4	15.0	58.0	38.1			
ST23311 - 12 - 16	19	3/4	- 12	1	15.0	58.0	44.5			
ST23311 - 16 - 12	25	1	- 16	3/4	15.0	60.5	38.1			
ST23311 - 16 - 16	25	1	- 16	1	20.0	64.3	44.5			
ST23311 - 16 - 20	25	1	- 16	1.1/4	20.0	64.5	50.8			
ST23311 - 20 - 16	31	1.1/4	- 20	1	20.0	64.5	44.6			
ST23311 - 20 - 20	31	1.1/4	- 20	1.1/4	25.0	64.3	50.8			
ST23311 - 20 - 24	31	1.1/4	- 20	1.1/2	25.0	72.5	60.3			
ST23311 - 24 - 24	38	1.1/2	- 24	1.1/2	32.0	75.6	60.3			
ST23311 - 24 - 32	38	1.1/2	- 24	2	32.0	75.6	71.4			
ST23311 - 32 - 32	51	2	- 32	2	42.0	78.9	71.4			
ST23311 - 32 - 40	51	2	- 32	2.1/2	42.0	80.9	84.1			
ST23311 - 40 - 40	63	2.1/2	- 40	2.1/2	54.0	76.0	84.1			
ST23311 - 48 - 48	76	3	- 48	3	65.0	80.0	101.6			

ST23321

(SAE J516/ISO 12151-3)
22.5° SAE FLANGE 3000PSI
CODE 61

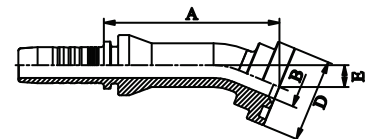

PART. REF.	HOSE BORE			FLANGE CODE 61	DIMENSIONS					
	DN	INCH	SIZE		B	A	D	E		
ST23321 - 08 - 08	12	1/2	08	1/2	9.3	63.9	30.3	8.0		
ST23321 - 12 - 12	19	3/4	12	3/4	15.0	74.7	38.1	9.8		
ST23321 - 12 - 16	19	3/4	12	1	15.0	74.7	44.5	11.0		
ST23321 - 16 - 16	25	1	16	1	20.0	88.8	44.5	11.5		
ST23321 - 16 - 20	25	1	16	1.1/4	26.0	88.5	50.8	11.5		
ST23321 - 20 - 20	31	1.1/4	20	1.1/4	26.0	100.0	50.8	12.0		
ST23321 - 20 - 24	31	1.1/4	20	1.1/2	25.0	101.8	60.3	15.0		
ST23321 - 24 - 24	38	1.1/2	24	2	32.0	116.5	60.3	14.0		

ST23331

(SAE J516/ISO 12151-3)
30° SAE FLANGE 3000PSI
CODE 61

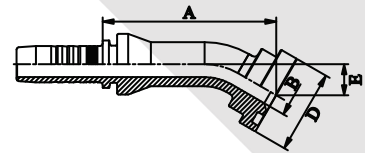

PART. REF.	HOSE BORE			FLANGE CODE 61	DIMENSIONS					
	DN	INCH	SIZE		B	A	D	E		
ST23331 - 08 - 08	12	1/2	- 08	1/2	9.5	62.6	30.2	12.0		
ST23331 - 12 - 12	19	3/4	- 12	3/4	15.0	73.2	38.1	13.9		
ST23331 - 12 - 16	19	3/4	- 12	1	20.0	73.2	44.5	13.9		
ST23331 - 16 - 16	25	1	- 16	1	20.0	86.8	44.5	18.0		
ST23331 - 20 - 20	31	1.1/4	- 20	1.1/4	25.0	98.0	50.8	22.0		
ST23331 - 24 - 24	38	1.1/2	- 24	1.1/2	32.0	114.3	60.3	20.0		

ST23341

(SAE J516/ISO 12151-3)
45° SAE FLANGE 3000PSI
CODE 61

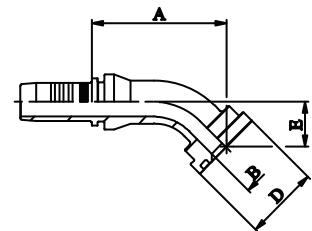

PART. REF.	HOSE BORE			FLANGE CODE 61	DIMENSIONS					
	DN	INCH	SIZE		B	A	D	E		
ST23341 - 08 - 08	12	1/2	08	1/2	9.5	58.5	30.2	18.5		
ST23341 - 08 - 12	12	1/2	08	3/4	9.5	59.5	38.1	19.0		
ST23341 - 10 - 12	16	5/8	10	3/4	15.0	61.0	38.1	22.0		
ST23341 - 12 - 12	19	3/4	12	3/4	15.0	68.5	38.1	23.0		
ST23341 - 12 - 16	19	3/4	12	1	15.0	70.5	44.5	25.0		
ST23341 - 16 - 16	25	1	16	1	20.0	81.5	44.5	27.5		
ST23341 - 16 - 20	25	1	16	1.1/4	20.0	81.5	50.8	27.5		
ST23341 - 20 - 20	31	1.1/4	20	1.1/4	25.0	94.5	50.8	32.0		
ST23341 - 20 - 24	31	1.1/4	20	1.1/2	25.0	94.5	60.3	32.0		
ST23341 - 24 - 24	38	1.1/2	24	1.1/2	32.0	107.5	60.3	34.5		
ST23341 - 24 - 32	38	1.1/2	24	2	32.0	107.5	71.4	40.0		
ST23341 - 32 - 32	51	2	32	2	42.0	140.0	71.4	55.0		
ST23341 - 40 - 40	63	2.1/2	40	2.1/2	54.0	175.0	84.1	60.0		
ST23341 - 48 - 48	76	3	48	3	65.0	220.0	101.6	80.0		

ST23361

(SAE J516/ISO 12151-3)
60° SAE FLANGE 3000PSI
CODE 61

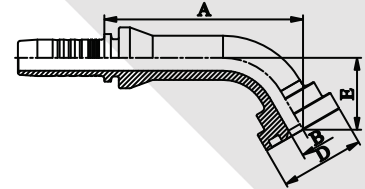

PART. REF.	HOSE BORE			FLANGE CODE 61	DIMENSIONS					
	DN	INCH	SIZE		B	A	D	E		
ST23361 - 08 - 08	12	1/2	- 08	1/2	9.3	71.5	30.2	25.8		
ST23361 - 12 - 12	16	3/4	- 12	3/4	15.0	86.9	38.1	33.0		
ST23361 - 16 - 16	25	1	- 16	1	19.8	104.0	44.5	39.0		
ST23361 - 16 - 20	25	1	- 16	1.1/4	26.0	104.0	44.5	39.0		
ST23361 - 20 - 20	31	1.1/4	- 20	1.1/4	25.0	120.0	50.8	50.0		
ST23361 - 20 - 24	31	1.1/4	- 20	1.1/2	32.0	121.0	60.3	44.7		
ST23361 - 24 - 24	38	1.1/2	- 24	1.1/2	32.0	143.6	60.3	50.7		

ST23371

(SAE J516/ISO 12151-3)
67.5° SAE FLANGE 3000PSI
CODE 61

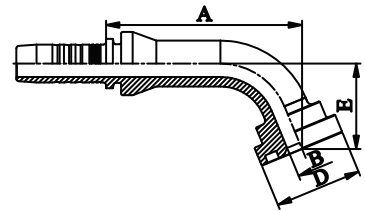

PART. REF.	HOSE BORE			FLANGE CODE 61	DIMENSIONS					
	DN	INCH	SIZE		B	A	D	E		
ST23371 - 08 - 08	12	1/2	- 08	1/2	9.3	67.9	30.2	29.3		
ST23371 - 12 - 12	19	3/4	- 12	3/4	15.0	82.2	38.1	38.0		
ST23371 - 12 - 16	19	3/4	- 12	1	20.0	82.2	44.5	38.0		
ST23371 - 16 - 16	25	1	- 16	1	19.8	98.6	44.5	45.0		
ST23371 - 16 - 20	25	1	- 16	1.1/4	26.0	98.5	50.8	45.0		
ST23371 - 20 - 20	31	1.1/4	- 20	1.1/4	26.0	114.0	50.8	50.0		
ST23371 - 24 - 24	38	1.1/2	- 24	1.1/2	32.0	136.4	60.3	59.2		

ST23391

(SAE J516/ISO 12151-3)
90° SAE FLANGE 3000PSI
CODE 61

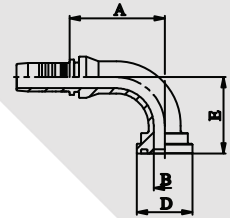

PART. REF.	HOSE BORE			FLANGE CODE 61	DIMENSIONS					
	DN	INCH	SIZE		B	A	D	E		
ST23391 - 08 - 08	12	1/2	- 08	1/2	9.5	54.5	30.2	41.0		
ST23391 - 08 - 12	12	1/2	- 08	3/4	9.5	54.5	38.1	41.0		
ST23391 - 10 - 12	16	5/8	- 10	3/4	12.0	56.0	38.1	47.5		
ST23391 - 12 - 12	19	3/4	- 12	3/4	15.0	64.5	38.1	52.0		
ST23391 - 12 - 12120	19	3/4	- 12	3/4	15.0	64.5	38.1	120.0		
ST23391 - 12 - 12160	19	3/4	- 12	3/4	20.0	64.5	44.5	160.0		
ST23391 - 12 - 16	19	3/4	- 12	1	15.0	64.5	44.5	52.0		
ST23391 - 16 - 16	25	1	- 16	1	20.0	77.5	44.5	62.0		
ST23391 - 16 - 16120	25	1	- 16	1	20.0	77.5	44.5	120.0		
ST23391 - 16 - 20	25	1	- 16	1.1/4	20.0	77.5	50.8	65.0		
ST23391 - 16 - 20120	25	1	- 16	1.1/4	26.0	77.5	50.8	120.0		
ST23391 - 20 - 20	31	1.1/4	- 20	1.1/4	25.0	90.5	50.8	75.0		
ST23391 - 20 - 24	31	1.1/4	- 20	1.1/2	25.0	90.5	60.3	80.0		
ST23391 - 24 - 20	38	1.1/2	- 24	1.1/4	32.0	104.5	50.8	75.0		
ST23391 - 24 - 24	38	1.1/2	- 24	1.1/2	32.0	107.5	60.3	90.0		
ST23391 - 24 - 24120	38	1.1/2	- 24	1.1/2	32.0	90.5	60.3	120.0		
ST23391 - 24 - 32	38	1.1/2	- 24	2	32.0	108.0	71.4	95.0		
ST23391 - 32 - 32	51	2	- 32	2	42.0	135.0	71.4	130.0		
ST23391 - 40 - 40	63	2.1/2	- 40	2.1/2	54.0	175.0	84.1	150.0		
ST23391 - 48 - 48	76	3	- 48	3	65.0	211.0	101.6	185.0		

ST23611

(SAE J516/ISO 12151-3)
STRAIGHT SAE FLANGE 6000PSI
CODE 62

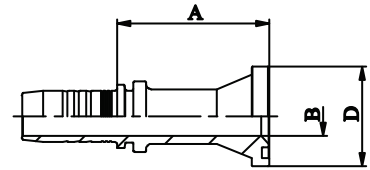

PART. REF.	HOSE BORE			FLANGE CODE 62	DIMENSIONS					
	DN	INCH	SIZE		B	A	D			
ST23611 - 08 - 08	12	1/2	- 08	1/2	9.5	52.1	31.8			
ST23611 - 08 - 12	12	1/2	- 08	3/4	9.5	68.4	41.3			
ST23611 - 10 - 08	16	5/8	- 10	1/2	9.3	52.0	31.8			
ST23611 - 10 - 12	16	5/8	- 10	3/4	12.0	70.2	41.3			
ST23611 - 12 - 12	19	3/4	- 12	3/4	15.0	69.0	41.3			
ST23611 - 12 - 16	19	3/4	- 12	5/8	15.0	81.0	47.6			
ST23611 - 16 - 12	25	1	- 16	3/4	20.0	81.0	41.3			
ST23611 - 16 - 16	25	1	- 16	5/8	20.0	82.3	47.6			
ST23611 - 16 - 20	25	1	- 16	1.1/4	20.0	89.8	54.0			
ST23611 - 20 - 20	31	1.1/4	- 20	1.1/4	25.0	84.5	54.0			
ST23611 - 20 - 24	31	1.1/4	- 20	1.1/2	25.0	90.5	63.5			
ST23611 - 24 - 24	38	2.3/8	- 24	1.1/2	32.0	92.6	63.5			
ST23611 - 32 - 32	51	2	- 32	2	42.0	78.9	79.4			

ST23641

(SAE J516/ISO 12151-3)
45° SAE FLANGE 6000PSI
CODE 62

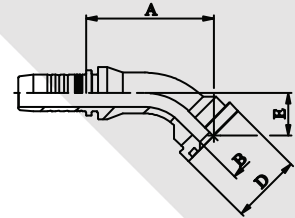

PART. REF.	HOSE BORE			FLANGE CODE 62	DIMENSIONS			
	DN	INCH	SIZE		B	A	D	E
ST23641 - 08 - 08	12	1/2	- 08	1/2	9.5	62.0	31.8	22.0
ST23641 - 08 - 12	12	1/2	- 08	3/4	9.5	59.5	41.3	25.0
ST23641 - 10 - 12	16	5/8	- 10	3/4	12.0	65.0	41.3	26.0
ST23641 - 12 - 12	19	3/4	- 12	3/4	15.0	73.0	41.3	28.0
ST23641 - 12 - 16	19	3/4	- 12	1	15.0	77.0	47.6	32.5
ST23641 - 16 - 12	25	1	- 16	3/4	15.0	80.0	41.3	30.0
ST23641 - 16 - 16	25	1	- 16	1	20.0	83.5	47.6	32.5
ST23641 - 16 - 20	25	1	- 16	1.1/4	20.0	88.5	54.0	37.5
ST23641 - 20 - 20	31	1.1/4	- 20	1.1/4	25.0	100.0	54.0	37.5
ST23641 - 20 - 24	31	1.1/4	- 20	1.1/2	32.0	102.5	63.5	45.0
ST23641 - 24 - 24	38	1.1/2	- 24	1.1/2	32.0	118.0	63.5	44.0
ST23641 - 32 - 32	51	2	- 32	2	42.0	151.7	79.4	56.0

ST23691

(SAE J516/ISO 12151-3)
90° SAE FLANGE 6000PSI
CODE 62

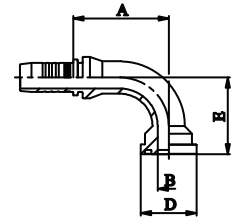

PART. REF.	HOSE BORE			FLANGE CODE 62	DIMENSIONS			
	DN	INCH	SIZE		B	A	D	E
ST23691 - 08 - 08	12	1/2	- 08	1/2	9.3	54.5	31.8	45.0
ST23691 - 08 - 12	12	1/2	- 08	3/4	15.0	54.5	41.3	53.0
ST23691 - 10 - 12	16	5/8	- 10	3/4	12.0	56.0	41.3	58.0
ST23691 - 12 - 12	19	3/4	- 12	3/4	15.0	64.0	41.3	59.0
ST23691 - 12 - 16	19	3/4	- 12	1	15.0	64.5	47.6	65.0
ST23691 - 16 - 12	25	1	- 16	3/4	20.0	74.2	41.3	68.0
ST23691 - 16 - 16	25	1	- 16	1	20.0	73.5	47.6	65.0
ST23691 - 16 - 20	25	1	- 16	1.1/4	20.0	73.5	54.0	75.0
ST23691 - 20 - 20	31	1.1/4	- 20	1.1/4	25.0	85.5	54.0	81.0
ST23691 - 20 - 24	31	1.1/4	- 20	1.1/2	25.0	91.5	63.5	85.5
ST23691 - 24 - 24	38	1.1/2	- 24	1.1/2	32.0	106.0	63.5	94.5
ST23691 - 32 - 32	51	2	- 32	2	42.0	138.0	79.4	132.0

ST23911

STRAIGHT "SUPERCAT" STYLE FLANGE
CODE SUPERCAT

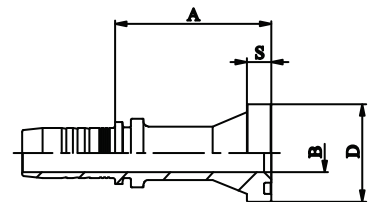

PART. REF.	HOSE BORE			FLANGE CATERPILAR	DIMENSIONS			
	DN	INCH	SIZE		B	A	D	S
ST23911 - 12 - 12	19	3/4	- 12	3/4	15.0	74.5	41.3	14.3
ST23911 - 16 - 16	25	1	- 16	1	20.0	86.8	47.6	14.3
ST23911 - 16 - 20	25	1	- 16	1.1/4	20.0	92.3	54.0	14.3
ST23911 - 20 - 20	31	1.1/4	- 20	1.1/4	25.0	86.0	54.0	14.3
ST23911 - 24 - 24	38	1.1/2	- 24	1.1/2	32.0	94.0	63.5	14.3

ST23941

45° "SUPERCAT" STYLE FLANGE
CODE SUPERCAT

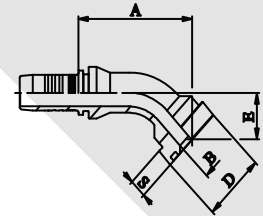

PART. REF.	HOSE BORE			FLANGE CATERPILAR	DIMENSIONS				
	DN	INCH	SIZE		B	A	D	E	S
ST23941 - 12 - 12	19	3/4	- 12	3/4	15.0	89.0	41.3	32.0	14.3
ST23941 - 16 - 16	25	1	- 16	1	20.0	89.5	47.6	36.5	14.3
ST23941 - 16 - 20	25	1	- 16	1.1/4	20.0	92.5	54.0	40.5	14.3
ST23941 - 20 - 20	31	1.1/4	- 20	1.1/4	25.0	102.0	54.0	41.5	14.3

ST23991

90° "SUPERCAT" STYLE FLANGE
CODE SUPERCAT

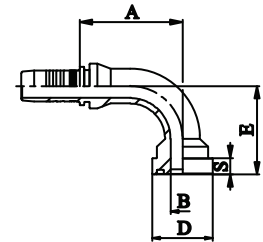

PART. REF.	HOSE BORE			FLANGE CATERPILAR	DIMENSIONS				
	DN	INCH	SIZE		B	A	D	E	S
ST23991 - 12 - 12	19	3/4	- 12	3/4	15.0	64.5	41.3	64.6	14.3
ST23991 - 16 - 16	25	1	- 16	1	20.0	77.5	47.6	76.5	14.3
ST23991 - 16 - 20	25	1	- 16	1.1/4	20.0	75.5	54.0	80.5	14.3
ST23991 - 20 - 20	31	1.1/4	- 20	1.1/4	25.0	85.5	54.0	87.0	14.3

ST24111

STRAIGHT "KOMATSU" STYLE FLANGE
CODE KOMATSU

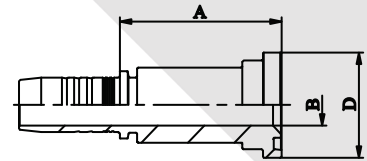

PART. REF.	HOSE BORE			FLANGE CODE 61	DIMENSIONS					
	DN	INCH	SIZE		B	A	D			
ST24111 - 10 - 10	16	5/8	- 10	5/8	12.0	65.7	34.2			

ST24141

45° "KOMATSU" STYLE FLANGE
CODE KOMATSU

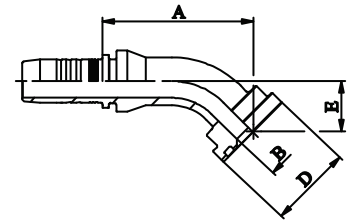

PART. REF.	HOSE BORE			FLANGE CODE 61	DIMENSIONS					
	DN	INCH	SIZE		B	A	D	E		
ST24141 - 10 - 10	16	5/8	- 10	5/8	12.0	61.0	34.2	22.0		

ST24191

45° "KOMATSU" STYLE FLANGE
CODE KOMATSU

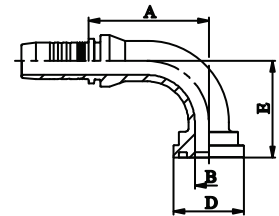

PART. REF.	HOSE BORE			FLANGE CODE 61	DIMENSIONS					
	DN	INCH	SIZE		B	A	C	E		
ST24191 - 10 - 10	16	5/8	- 10	5/8	14.0	56.0	34.0	47.5		

ST10510

(BS5200/ISO 8434-6)

BSP MALE PARALLEL 60° CONE SEAT

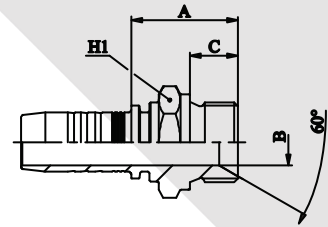

PART. REF.	HOSE BORE			THREAD	DIMENSIONS					
	DN	INCH	SIZE	BSP	B	A	C			H1
ST10510 - 03 - 02	5	3/16	- 03	1/8 - 28	3.1	22.5	10.0			14
ST10510 - 04 - 02	6	1/4	- 04	1/8 - 28	4.1	22.5	10.0			14
ST10510 - 04 - 04	6	1/4	- 04	1/4 - 19	4.1	25.5	11.0			19
ST10510 - 04 - 06	6	1/4	- 04	3/8 - 19	4.1	27.0	12.0			22
ST10510 - 05 - 06	8	5/16	- 05	3/8 - 19	8.0	27.5	12.0			22
ST10510 - 06 - 04	10	3/8	- 06	1/4 - 19	7.0	26.0	11.0			19
ST10510 - 06 - 06	10	3/8	- 06	3/8 - 19	7.0	28.1	13.5			22
ST10510 - 06 - 08	10	3/8	- 06	1/2 - 14	7.0	30.6	14.0			22
ST10510 - 08 - 06	12	1/2	- 08	3/8 - 19	9.5	28.1	12.0			22
ST10510 - 08 - 08	12	1/2	- 08	1/2 - 14	9.5	31.1	14.0			27
ST10510 - 08 - 10	12	1/2	- 08	5/8 - 14	9.5	33.1	16.0			30
ST10510 - 08 - 12	12	1/2	- 08	3/4 - 14	9.5	34.1	16.0			32
ST10510 - 10 - 10	16	5/8	- 10	5/8 - 14	12.0	33.1	16.0			30
ST10510 - 10 - 12	16	5/8	- 10	3/4 - 14	12.0	34.1	16.0			32
ST10510 - 12 - 12	19	3/4	- 12	3/4 - 14	15.0	35.5	16.0			32
ST10510 - 12 - 16	19	3/4	- 12	1 - 11	15.0	39.5	19.0			41
ST10510 - 16 - 16	25	1	- 16	1 - 11	20.0	40.8	19.0			41
ST10510 - 16 - 20	25	1	- 16	1.1/4 - 11	20.0	44.8	20.0			50
ST10510 - 20 - 20	31	1.1/4	- 20	1.1/4 - 11	25.0	46.5	20.0			50
ST10510 - 24 - 24	38	1.1/2	- 24	1.1/2 - 11	32.0	51.0	22.0			55
ST10510 - 32 - 32	51	2	- 32	2 - 11	42.0	58.0	25.0			70

ST10610

BSP MALE FLAT SEAT

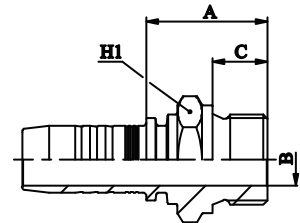

PART. REF.	HOSE BORE			THREAD	DIMENSIONS					
	DN	INCH	SIZE	BSP	B	A	C			H1
ST10610 - 04 - 04	6	1/4	- 04	1/4 - 19	4.1	25.5	11.0			19
ST10610 - 06 - 06	10	3/8	- 06	3/8 - 19	9.5	28.1	12.0			22
ST10610 - 06 - 08	10	3/8	- 06	1/2 - 14	13.0	30.6	14.0			27
ST10610 - 08 - 08	12	1/2	- 08	1/2 - 14	13.0	31.1	14.0			27
ST10610 - 12 - 12	19	3/4	- 12	3/4 - 14	18.0	35.5	16.0			32
ST10610 - 16 - 16	25	1	- 16	1 - 11	20.0	40.8	19.0			41

ST10710

(ISO 7)

BSP MALE TAPERED

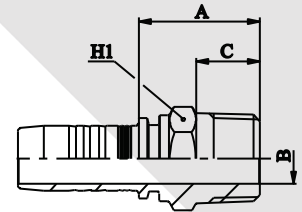

PART. REF.	HOSE BORE			THREAD	DIMENSIONS				
	DN	INCH	SIZE	BSP	B	A	C		H1
ST10710 - 04 - 02	6	1/4	- 04	1/8 - 28	4.1	20.6	10.5		12
ST10710 - 04 - 04	6	1/4	- 04	1/4 - 19	4.1	25.0	12.5		14
ST10710 - 06 - 06	10	3/8	- 06	3/8 - 19	7.0	27.1	15.0		19
ST10710 - 06 - 08	10	3/8	- 06	1/2 - 14	10.0	30.6	15.0		22
ST10710 - 08 - 08	12	1/2	- 08	1/2 - 14	10.0	31.1	15.0		22
ST10710 - 10 - 12	16	5/8	- 10	3/4 - 14	17.0	37.0	17.0		27
ST10710 - 12 - 12	19	3/4	- 12	3/4 - 14	17.0	35.5	17.0		27
ST10710 - 16 - 16	25	1	- 16	1 - 11	22.5	41.8	21.0		36
ST10710 - 20 - 20	31	1.1/4	- 20	1.1/4 - 11	28.5	47.5	23.0		46

ST20612/13

[THRUST WIRE/SLIP-ON NUT]

BSP FEMALE FLAT SEAT

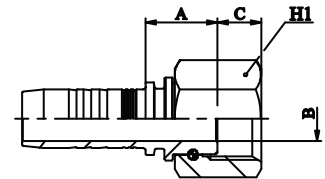

PART. REF.	HOSE BORE			THREAD	DIMENSIONS				
	DN	INCH	SIZE	BSP	B	A	C		H1
ST20613 - 04 - 04	6	1/4	- 04	1/4 - 19	4.1	17.0	8.0		19
ST20613 - 06 - 06	10	3/8	- 06	3/8 - 19	7.0	18.0	9.0		22
ST20613 - 06 - 08	10	3/8	- 06	1/2 - 14	7.0	19.5	11.0		27
ST20613 - 08 - 08	12	1/2	- 08	1/2 - 14	9.3	17.9	9.8		27
ST20612 - 08 - 12	12	1/2	- 08	3/4 - 14	15.0	20.9	11.5		32
ST20612 - 10 - 10	16	5/8	- 10	5/8 - 14	*	*	*		*
ST20612 - 10 - 12	16	5/8	- 10	3/4 - 14	15.0	20.7	11.5		32
ST20612 - 12 - 12	19	3/4	- 12	3/4 - 14	15.0	22.8	11.5		32
ST20612 - 12 - 16	19	3/4	- 12	1 - 11	15.0	23.5	13.0		38
ST20612 - 16 - 16	25	1	- 16	1 - 11	20.0	24.8	13.0		38

ST20812

(BS5200/ISO 12151-6)

BSP O'RING FEMALE 60° CONE SEAT
[THRUST WIRE]

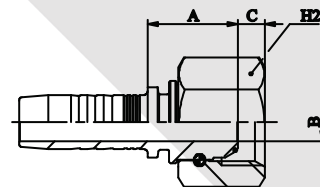

PART. REF.	HOSE BORE			THREAD	DIMENSIONS					
	DN	INCH	SIZE	BSP	B	A	C			H2
ST20812 - 03 - 02	5	3/16	- 03	1/8 - 28	3.1	15.8	4.5			14
ST20812 - 03 - 04	5	3/16	- 03	1/4 - 19	3.1	16.5	5.0			19
ST20812 - 04 - 02	6	1/4	- 04	1/8 - 28	4.1	16.5	4.5			14
ST20812 - 04 - 04	6	1/4	- 04	1/4 - 19	4.1	18.5	5.0			19
ST20812 - 04 - 06	6	1/4	- 04	3/8 - 19	4.1	18.1	5.5			22
ST20812 - 05 - 04	8	5/16	- 05	1/4 - 19	5.5	17.5	5.0			19
ST20812 - 05 - 06	8	5/16	- 05	3/8 - 19	5.5	19.1	5.5			22
ST20812 - 06 - 04	10	3/8	- 06	1/4 - 19	7.0	18.5	5.0			19
ST20812 - 06 - 06	10	3/8	- 06	3/8 - 19	7.0	20.4	5.5			22
ST20812 - 06 - 08	10	3/8	- 06	1/2 - 14	7.0	23.8	6.5			27
ST20812 - 08 - 06	12	1/2	- 08	3/8 - 19	9.5	21.0	5.5			22
ST20812 - 08 - 08	12	1/2	- 08	1/2 - 14	9.5	22.2	6.5			27
ST20812 - 08 - 10	12	1/2	- 08	5/8 - 14	9.5	21.9	9.5			30
ST20812 - 08 - 12	12	1/2	- 08	3/4 - 14	9.5	23.4	9.0			32
ST20812 - 10 - 10	16	5/8	- 10	5/8 - 14	12.0	22.1	9.5			30
ST20812 - 10 - 12	16	5/8	- 10	3/4 - 14	12.0	23.2	9.0			32
ST20812 - 12 - 12	19	3/4	- 12	3/4 - 14	15.0	25.0	9.0			32
ST20812 - 12 - 16	19	3/4	- 12	1 - 11	15.0	26.0	10.0			38
ST20812 - 16 - 12	25	1	- 16	3/4 - 14	19.0	26.5	9.0			32
ST20812 - 16 - 16	25	1	- 16	1 - 11	20.0	27.8	10.0			38
ST20812 - 16 - 20	25	1	- 16	1.1/4 - 11	19.7	30.8	10.5			50
ST20812 - 20 - 16	31	1.1/4	- 20	1 - 11	25.0	29.0	10.0			38
ST20812 - 20 - 20	31	1.1/4	- 20	1.1/4 - 11	25.0	31.5	10.5			50
ST20812 - 20 - 24	31	1.1/4	- 20	1.1/2 - 11	25.0	29.5	12.5			55
ST20812 - 24 - 20	38	1.1/2	- 24	1.1/4 - 11	32.0	31.5	10.5			50
ST20812 - 24 - 24	38	1.1/2	- 24	1.1/2 - 11	32.0	30.5	12.5			55
ST20812 - 24 - 32	38	1.1/2	- 24	2 - 11	32.0	30.0	16.0			70
ST20812 - 32 - 32	51	2	- 32	2 - 11	42.0	34.5	16.0			70

ST20842

(BS5200/ISO 12151-6)

45° BSP O'RING FEMALE 60° CONE SEAT
[THRUST WIRE]

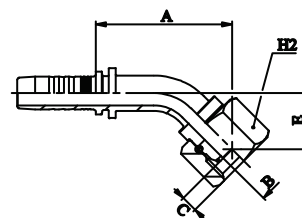

PART. REF.	HOSE BORE			THREAD	DIMENSIONS					
	DN	INCH	SIZE	BSP	B	A	C	E		H2
ST20842 - 04 - 02	6	1/4	- 04	1/8 - 28	4.1	36.0	4.5	15.0		14
ST20842 - 04 - 04	6	1/4	- 04	1/4 - 19	4.1	36.3	5.0	15.0		19
ST20842 - 04 - 06	6	1/4	- 04	3/8 - 19	4.1	37.5	5.5	16.0		22
ST20842 - 06 - 04	10	3/4	- 06	1/4 - 19	*	*	*	*		*
ST20842 - 06 - 06	10	3/4	- 06	3/8 - 19	7.0	44.5	5.5	18.5		22
ST20842 - 06 - 08	10	3/4	- 06	1/2 - 14	7.0	42.5	6.5	16.0		27
ST20842 - 08 - 08	12	1/2	- 08	1/2 - 14	9.5	52.0	6.5	20.5		27
ST20842 - 08 - 10	12	1/2	- 08	5/8 - 14	12.1	54.5	10.2	22.5		28
ST20842 - 08 - 12	12	1/2	- 08	3/4 - 14	15.0	57.0	9.0	25.0		32
ST20842 - 10 - 10	16	5/8	- 10	5/8 - 14	12.0	63.5	9.5	27.5		30
ST20842 - 10 - 12	16	5/8	- 10	3/4 - 14	15.0	64.0	9.0	27.0		32
ST20842 - 12 - 12	19	3/4	- 12	3/4 - 14	15.0	71.0	9.0	29.0		32
ST20842 - 12 - 16	19	3/4	- 12	1 - 11	19.8	72.5	10.5	30.0		38
ST20842 - 16 - 12	25	1	- 16	3/4 - 14	19.7	79.5	9.0	29.0		32
ST20842 - 16 - 16	25	1	- 16	1 - 11	20.0	90.5	10.0	35.6		38
ST20842 - 16 - 20	25	1	- 16	1.1/4 - 11	19.7	93.0	10.5	38.0		50
ST20842 - 20 - 20	31	1.1/4	- 20	1.1/4 - 11	25.0	101.5	10.5	39.0		50
ST20842 - 20 - 24	31	1.1/4	- 20	1.1/2 - 11	25.0	118.5	12.5	40.5		55
ST20842 - 24 - 20	38	1.1/2	- 24	1.1/4 - 11	32.0	106.5	10.5	42.0		50
ST20842 - 24 - 24	38	1.1/2	- 24	1.1/2 - 11	32.0	118.0	12.5	45.0		55
ST20842 - 32 - 32	51	2	- 32	2 - 11	42.0	144.0	16.0	58.0		70

ST20882

(BS5200/ISO 12151-6)

90° BSP O’RING FEMALE COMPACT ELBOW 60° CONE SEAT
[THRUST WIRE]

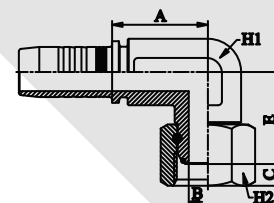

PART. REF.	HOSE BORE			THREAD	DIMENSIONS					
	DN	INCH	SIZE	BSP	B	A	C	E	H1	H2
ST20882 - 04 - 04	6	1/4	- 04	1/4 - 19	4.1	18.5	5.0	22.0	14	19
ST20882 - 06 - 06	10	3/8	- 06	3/8 - 19	7.0	23.1	5.5	27.5	19	22
ST20882 - 08 - 08	12	1/2	- 08	1/2 - 14	9.5	23.0	6.5	31.1	22	27
ST20882 - 10 - 10	16	5/8	- 10	5/8 - 14	12.0	24.6	9.5	32.5	24	30
ST20882 - 12 - 12	19	3/4	- 12	3/4 - 14	15.0	28.0	9.0	36.0	27	32
ST20882 - 16 - 16	25	1	- 16	1 - 11	20.0	30.0	10.0	43.0	36	38

ST20892

(BS5200/ISO 12151-6)

90° BSP O’RING FEMALE 60° CONE SEAT
[THRUST WIRE]

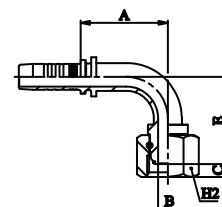

PART. REF.	HOSE BORE			THREAD	DIMENSIONS					
	DN	INCH	SIZE	BSP	B	A	C	E	H1	H2
ST20892 - 03 - 02	5	3/16	- 03	1/8 - 28	3.1	28.5	4.5	28.5		14
ST20892 - 04 - 02	6	1/4	- 04	1/8 - 28	4.1	28.5	4.5	28.5		14
ST20892 - 04 - 04	6	1/4	- 04	1/4 - 19	4.1	28.5	5.0	28.5		19
ST20892 - 04 - 06	6	1/4	- 04	3/8 - 19	4.1	28.5	5.5	30.0		22
ST20892 - 05 - 06	8	5/16	- 05	3/8 - 19	7.0	32.0	6.0	27.5		22
ST20892 - 05 - 08	8	5/16	- 05	1/2 - 14	9.3	36.5	6.5	32.0		27
ST20892 - 06 - 04	10	3/8	- 06	1/4 - 19	7.0	35.5	5.0	33.0		19
ST20892 - 06 - 06	10	3/8	- 06	3/8 - 19	7.0	35.5	5.5	36.0		22
ST20892 - 06 - 08	10	3/8	- 06	1/2 - 14	7.0	36.5	6.5	32.0		27
ST20892 - 08 - 06	12	1/2	- 08	3/8 - 19	7.0	45.0	6.0	41.0		22
ST20892 - 08 - 08	12	1/2	- 08	1/2 - 14	9.5	44.5	6.5	42.0		27
ST20892 - 08 - 10	12	1/2	- 08	5/8 - 14	12.1	44.0	10.2	44.0		28
ST20892 - 08 - 12	12	1/2	- 08	3/4 - 14	9.5	44.0	9.0	45.5		32
ST20892 - 10 - 10	16	5/8	- 10	5/8 - 14	12.0	53	9.5	55.0		30
ST20892 - 10 - 12	16	5/8	- 10	3/4 - 14	15.0	53.5	9.0	55.0		32
ST20892 - 12 - 12	19	3/4	- 12	3/4 - 14	19.7	61.5	9.0	60.0		32
ST20892 - 12 - 16	19	3/4	- 12	1 - 11	15.0	61.5	10.0	62.0		38
ST20892 - 16 - 12	25	1	- 16	3/4 - 14	19.7	79.5	9.0	60.0		32
ST20892 - 16 - 16	25	1	- 16	1 - 11	20.0	79.5	10.0	76.0		38
ST20892 - 16 - 20	25	1	- 16	1.1/4 - 11	19.7	79.5	10.5	78.5		50
ST20892 - 20 - 16	31	1.1/4	- 20	1 - 11	25.0	85.0	10.0	76.0		38
ST20892 - 20 - 20	31	1.1/4	- 20	1.1/4 - 11	25.0	90.5	10.5	83.5		50
ST20892 - 20 - 24	31	1.1/4	- 20	1.1/2 - 11	25.0	90.5	12.5	84.5		55
ST20892 - 24 - 20	38	1.1/2	- 24	1.1/4 - 11	32.0	95.0	10.5	90.5		50
ST20892 - 24 - 24	38	1.1/2	- 24	1.1/2 - 11	32.0	108.0	12.5	98.5		55
ST20892 - 32 - 32	51	2	- 32	2 - 11	42.0	134.8	16.0	120.0		70

ST20310

BSP BANJO

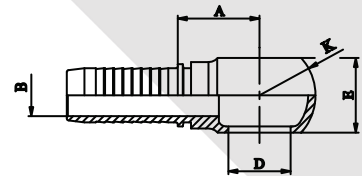

PART. REF.	HOSE BORE			BSP BOLT	DIMENSIONS				
	DN	INCH	SIZE	D	B	A	D	E	K
ST20310 - 03 - 02	5	3/16	- 03	1/8 - 28	3.1	18.0	9.9	16.0	22.0
ST20310 - 04 - 02	6	1/4	- 04	1/8 - 28	4.1	18.0	9.9	16.0	22.0
ST20310 - 04 - 04	6	1/4	- 04	1/4 - 19	4.1	22.0	13.3	14.0	24.0
ST20310 - 04 - 06	6	1/4	- 04	3/8 - 19	4.1	21.0	16.7	18.0	28.0
ST20310 - 06 - 04	10	3/8	- 06	1/4 - 19	*	*	*	*	*
ST20310 - 06 - 06	10	3/8	- 06	3/8 - 19	7.0	24.1	16.7	18.0	28.0
ST20310 - 06 - 08	10	3/8	- 06	1/2 - 14	7.0	27.1	21.2	22.0	35.0
ST20310 - 08 - 06	12	1/2	- 08	3/8 - 19	*	*	*	*	*
ST20310 - 08 - 08	12	1/2	- 08	1/4 - 14	9.5	27.5	21.2	22.0	35.0
ST20310 - 10 - 10	16	5/8	- 10	5/8 - 14	12.0	28.2	23.0	23.5	38.0
ST20310 - 12 - 12	19	3/4	- 12	3/4 - 14	15.0	36.5	26.7	29.0	45.0
ST20310 - 16 - 16	25	1	- 16	1 - 11	20.0	44.5	33.4	36.0	54.0

ST11110

(DIN20066/ISO 12151-2)

METRIC MALE 24° CONE SEAT
LIGHT TYPE DUTY

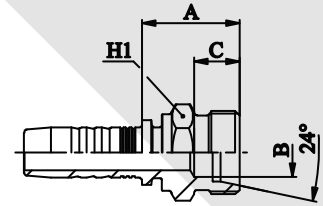

PART. REF.	HOSE BORE			THREAD	TUBE	DIMENSIONS				
	DN	INCH	SIZE	LT.METRIC	MM	B	A	C		H1
ST11110 - 04 - 12	6	1/4	- 04	M12X1.5	6	4.1	21.5	10.0		14
ST11110 - 04 - 14	6	1/4	- 04	M14X1.5	8	4.1	21.5	10.0		14
ST11110 - 04 - 16	6	1/4	- 04	M16X1.5	10	4.1	23.5	11.0		17
ST11110 - 04 - 18	6	1/4	- 04	M18X1.5	12	4.1	23.5	11.0		19
ST11110 - 05 - 16	8	5/16	- 05	M16X1.5	10	5.5	24.0	11.0		17
ST11110 - 05 - 18	8	5/16	- 05	M18X1.5	12	5.5	24.0	11.0		19
ST11110 - 06 - 16	10	3/8	- 06	M16X1.5	10	7.0	24.1	11.0		17
ST11110 - 06 - 18	10	3/8	- 06	M18X1.5	12	7.0	24.6	11.0		19
ST11110 - 06 - 22	10	3/8	- 06	M22X1.5	15	7.0	25.6	12.0		22
ST11110 - 08 - 18	12	1/2	- 08	M18X1.5	12	9.5	25.6	12.0		22
ST11110 - 08 - 22	12	1/2	- 08	M22X1.5	15	12.0	27.0	12.0		22
ST11110 - 08 - 26	12	1/2	- 08	M26X1.5	18	9.5	26.4	12.0		27
ST11110 - 10 - 22	16	5/8	- 10	M22X1.5	15	12.0	27.0	12.0		22
ST11110 - 10 - 26	16	5/8	- 10	M26X1.5	18	12.0	26.7	12.0		27
ST11110 - 10 - 30	16	5/8	- 10	M30X2.0	22	15.0	28.5	14.0		30
ST11110 - 12 - 26	19	3/4	- 12	M26X1.5	18	15.0	30.0	14.0		30
ST11110 - 12 - 30	19	3/4	- 12	M30X2.0	22	15.0	30.0	14.0		30
ST11110 - 16 - 36	25	1	- 16	M36X2.0	28	20.0	33.3	14.0		36
ST11110 - 20 - 45	31	1.1/4	- 20	M45X2.0	35	25.0	40.5	16.0		46
ST11110 - 24 - 52	38	1.1/2	- 24	M52X2.0	42	32.0	42.6	16.0		55

ST11210

(DIN20066/ISO 12151-2)

METRIC MALE 24° CONE SEAT
STRONG TYPE DUTY

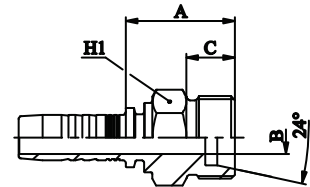

PART. REF.	HOSE BORE			THREAD	TUBE	DIMENSIONS				
	DN	INCH	SIZE	HT.METRIC	MM	B	A	C	H1	H1
ST11210 - 04 - 16	6	1/4	- 04	M16X1.5	8	4.1	25.5	12.0		17
ST11210 - 04 - 18	6	1/4	- 04	M18X1.5	10	4.1	26.5	12.0		19
ST11210 - 04 - 20	6	1/4	- 04	M20X1.5	12	7.0	29.0	12.0		22
ST11210 - 05 - 18	8	5/16	- 05	M18X1.5	10	*	*	*		*
ST11210 - 05 - 20	8	5/16	- 05	M20X1.5	12	5.5	29.0	12.0		22
ST11210 - 06 - 18	10	3/8	- 06	M18X1.5	10	7.0	27.1	12.0		19
ST11210 - 06 - 20	10	3/8	- 06	M20X1.5	12	7.0	29.1	12.0		22
ST11210 - 06 - 22	10	3/8	- 06	M22X1.5	14	7.0	31.1	14.0		22
ST11210 - 06 - 24	10	3/8	- 06	M24X1.5	16	*	*	*		*
ST11210 - 08 - 22	12	1/2	- 08	M22X1.5	14	9.3	31.5	14.0		22
ST11210 - 08 - 24	12	1/2	- 08	M24X1.5	16	9.5	31.6	14.0		24
ST11210 - 10 - 30	16	5/8	- 10	M30X2.0	20	12.0	35.7	16.0		30
ST11210 - 12 - 30	19	3/4	- 12	M30X2.0	20	15.0	37.0	16.0		30
ST11210 - 12 - 36	19	3/4	- 12	M36X2.0	25	15.0	41.0	18.0		36
ST11210 - 16 - 36	25	1	- 16	M36X2.0	25	20.0	42.3	18.0		36
ST11210 - 16 - 42	25	1	- 16	M42X2.0	30	20.0	44.3	20.0		46
ST11210 - 20 - 52	31	1.1/4	- 20	M52X2.0	38	25.0	50.5	22.0		55

ST11710

FRENCH METRIC MALE 24° CONE SEAT
MILLIMETRIC TYPE

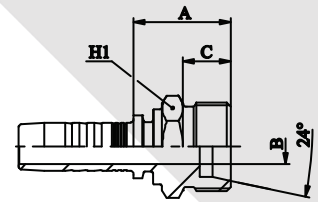

PART. REF.	HOSE BORE			THREAD	TUBE	DIMENSIONS				
	DN	INCH	SIZE	FR.METRIC	MM	B	A	C		H1
ST11710 - 10 - 2718	16	5/8	- 10	M27X1.5	18	12.5	28.7	14.0		28
ST11710 - 10 - 2720	16	5/8	- 10	M27X1.5	20	12.5	28.7	14.0		28
ST11710 - 12 - 30	19	3/4	- 12	M30X1.5	22	15.0	30.0	14.0		30
ST11710 - 12 - 33	19	3/4	- 12	M33X1.5	25	15.0	31.0	14.0		34

ST11810

FRENCH METRIC MALE 24° CONE SEAT
GAZ TYPE

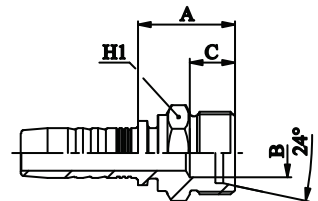

PART. REF.	HOSE BORE			THREAD	TUBE	DIMENSIONS				
	DN	INCH	SIZE	FR.METRIC	MM	B	A	C		H1
ST11810 - 05 - 20	8	5/16	- 05	M20X1.5	13.25	8.0	27.0	12.0		22
ST11810 - 06 - 20	10	3/8	- 06	M20X1.5	13.25	8.0	27.6	12.0		22
ST11810 - 06 - 24	10	3/8	- 06	M24X1.5	16.75	12.0	28.1	12.0		24
ST11810 - 08 - 24	12	1/2	- 08	M24X1.5	16.75	12.0	28.4	12.0		24
ST11810 - 10 - 30	16	5/8	- 10	M30X1.5	21.25	15.0	31.7	14.0		30
ST11810 - 12 - 36	19	3/4	- 12	M36X1.5	26.75	21.0	34.0	14.0		36
ST11810 - 16 - 45	25	1	- 16	M45X1.5	33.5	26.0	39.3	16.0		46

ST11813

FRENCH METRIC MALE 24° CONE SEAT
"KOBELCO" TYPE

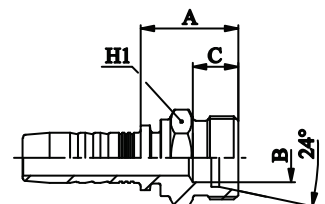

PART. REF.	HOSE BORE			THREAD	TUBE	DIMENSIONS				
	DN	INCH	SIZE	FR.METRIC	MM	B	A	C		H1
ST11813 - 10 - 30	16	5/8	- 10	M30X1.5	22	12.0	29.5	14.0		30
ST11813 - 12 - 30	19	3/4	- 12	M30X1.5	22	15.0	30.0	14.0		30
ST11813 - 12 - 36	19	3/4	- 12	M36X1.5	28	15.0	32.5	14.0		36
ST11813 - 16 - 45	25	1	- 16	M45X1.5	34	20.0	39.7	16.0		46

ST20910
(DIN7642)
METRIC BANJO

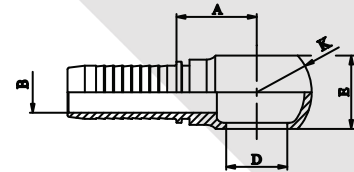

PART. REF.	HOSE BORE			METRIC BOLT	DIMENSIONS				
	DN	INCH	SIZE	D	B	A	D	E	K
ST20910 - 03 - 10	5	3/16	- 03	M10X1.0	3.1	20.0	10.0	10.0	17.0
ST20910 - 04 - 10	6	1/4	- 04	M10X1.0	4.1	20.5	10.0	10.0	17.0
ST20910 - 04 - 12	6	1/4	- 04	M12X1.5	4.1	21.0	12.0	12.0	22.0
ST20910 - 04 - 14	6	1/4	- 04	M14X1.5	4.1	21.5	14.0	14.0	24.0
ST20910 - 05 - 14	8	5/16	- 05	M14X1.5	5.1	23.1	14.0	14.0	24.0
ST20910 - 05 - 16	8	5/16	- 05	M16X1.5	*	*	*	*	*
ST20910 - 06 - 14	10	3/8	- 06	M14X1.5	7.0	24.1	14.0	14.0	24.0
ST20910 - 06 - 16	10	3/8	- 06	M16X1.5	7.0	24.1	16.0	18.0	28.0
ST20910 - 06 - 18	10	3/8	- 06	M18X1.5	7.0	27.1	18.0	20.0	32.0
ST20910 - 08 - 18	12	1/2	- 08	M18X1.5	9.5	27.5	18.0	20.0	32.0
ST20910 - 08 - 22	12	1/2	- 08	M22X1.5	9.5	27.5	22.0	22.0	35.0
ST20910 - 10 - 22	16	5/8	- 10	M22X1.5	12.0	28.2	22.0	23.5	38.0
ST20910 - 12 - 26	19	3/4	- 12	M26X1.5	15.0	36.5	26.0	29.0	45.0

ST21512/ST21513

(DIN20066/ISO 12151-2)
O'RING METRIC FEMALE 24° CONE
LIGHT TYPE DUTY
[THRUST WIRE/SLIP-ON NUT]

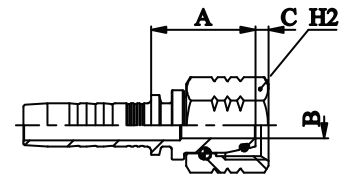

PART. REF.	HOSE BORE			THREAD	TUBE	DIMENSIONS				
	DN	INCH	SIZE	LT.METRIC	MM	B	A	C		H2
ST21513 - 03 - 12	5	3/16	- 03	M12X1.5	6	2.5	21.9	1.0		14
ST21512 - 04 - 12	6	1/4	- 04	M12X1.5	6	2.5	21.1	1.0		14
ST21513 - 04 - 14	6	1/4	- 04	M14X1.5	8	4.1	22.1	2.0		17
ST21513 - 04 - 16	6	1/4	- 04	M16X1.5	10	5.5	22.6	2.0		19
ST21513 - 04 - 18	6	1/4	- 04	M18X1.5	12	7.0	23.5	1.5		22
ST21512 - 05 - 14	8	5/16	- 05	M14X1.5	8	4.0	22.4	1.0		17
ST21513 - 05 - 16	8	5/16	- 05	M16X1.5	10	5.5	22.6	2.0		19
ST21513 - 05 - 18	8	5/16	- 05	M18X1.5	12	7.0	22.5	1.5		22
ST21512 - 06 - 16	10	3/8	- 06	M16X1.5	10	5.5	23.1	1.5		19
ST21513 - 06 - 18	10	3/8	- 06	M18X1.5	12	7.0	23.4	1.5		22
ST21513 - 06 - 22	10	3/8	- 06	M22X1.5	15	9.5	25.0	2.5		27
ST21512 - 08 - 18	12	1/2	- 08	M18X1.5	12	7.0	29.0	1.0		22
ST21513 - 08 - 22	12	1/2	- 08	M22X1.5	15	9.5	25.4	2.5		27
ST21513 - 08 - 26	12	1/2	- 08	M26X1.5	18	12.0	30.0	2.5		32
ST21513 - 10 - 26	16	5/8	- 10	M26X1.5	18	12.0	29.0	2.5		32
ST21513 - 10 - 30	16	5/8	- 10	M30X2.0	22	15.0	34.0	4.0		36
ST21512 - 12 - 26	19	3/4	- 12	M26X1.5	18	12.0	31.1	2.0		32
ST21513 - 12 - 30	19	3/4	- 12	M30X2.0	22	15.0	29.2	4.0		36
ST21513 - 12 - 36	19	3/4	- 12	M36X2.0	28	20.0	32.5	4.0		41
ST21513 - 16 - 36	25	1	- 16	M36X2.0	28	20.0	32.5	4.0		41
ST21513 - 20 - 45	31	1.1/4	- 20	M45X2.0	35	25.0	35.0	5.0		50
ST21513 - 24 - 52	38	1.1/2	- 24	M52X2.0	42	32.0	34.0	5.5		60

ST21542/ST21543

(DIN20066/ISO 12151-2)

45° O’RING METRIC FEMALE 24° CONE

LIGHT TYPE DUTY

[THRUST WIRE/SLIP-ON NUT]

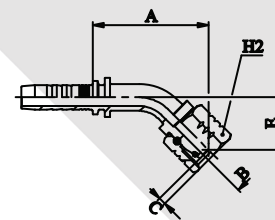

PART. REF.	HOSE BORE			THREAD LT.METRIC	PIPE MM	DIMENSIONS				
	DN	INCH	SIZE			B	A	C	E	H2
ST21543 - 04 - 14	6	1/4	- 04	M14X1.5	8	4.1	38.0	2.0	16.5	17
ST21543 - 04 - 16	6	1/4	- 04	M16X1.5	10	5.5	38.0	2.0	17.0	19
ST21543 - 05 - 16	8	5/16	- 05	M16X1.5	10	5.5	41.5	2.0	17.5	19
ST21543 - 05 - 18	8	5/16	- 05	M18X1.5	12	7.0	38.5	2.3	17.5	22
ST21542 - 06 - 16	10	3/8	- 06	M16X1.5	10	5.5	47.5	1.5	21.5	19
ST21543 - 06 - 18	10	3/8	- 06	M18X1.5	12	7.0	43.5	1.5	17.0	22
ST21543 - 06 - 22	10	3/8	- 06	M22X1.5	15	9.5	45.0	2.5	18.0	27
ST21543 - 08 - 22	12	1/2	- 08	M22X1.5	15	9.5	52.0	2.5	19.5	27
ST21543 - 10 - 26	16	5/8	- 10	M26X1.5	18	12.0	62.0	2.5	26.5	32
ST21543 - 12 - 30	19	3/4	- 12	M30X2.0	22	15.0	71.0	4.0	28.5	36
ST21543 - 16 - 36	25	1	- 16	M36X2.0	28	20.0	85.0	4.0	32.0	41
ST21543 - 20 - 45	31	1.1/4	- 20	M45X2.0	35	25.0	99.5	5.0	36.0	50
ST21543 - 24 - 52	38	1.1/2	- 24	M52X2.0	42	32.0	117.0	5.5	44.5	60

ST21592/ST21593

(DIN20066/ISO 12151-2)

90° O’RING METRIC FEMALE 24° CONE

LIGHT TYPE DUTY

[THRUST WIRE/SLIP-ON NUT]

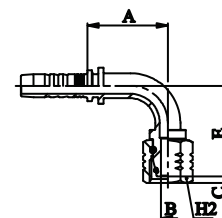

PART. REF.	HOSE BORE			THREAD LT.METRIC	PIPE MM	DIMENSIONS				
	DN	INCH	SIZE			B	A	C	E	H2
ST21593 - 03 - 12	5	3/16	- 03	M12X1.5	6	2.5	26.0	1.0	30.0	14
ST21592 - 04 - 12	6	1/4	- 04	M12X1.5	6	2.5	28.5	1.0	32.5	14
ST21593 - 04 - 14	6	1/4	- 04	M14X1.5	8	4.1	29.5	2.0	31.5	17
ST21593 - 04 - 16	6	1/4	- 04	M16X1.5	10	5.5	29.5	2.0	32.0	19
ST21593 - 04 - 18	6	1/4	- 04	M18X1.5	12	7.0	29.5	1.5	33.0	22
ST21593 - 05 - 16	8	5/16	- 05	M16X1.5	10	5.5	32.0	2.0	32.5	19
ST21593 - 05 - 18	8	5/16	- 05	M18X1.5	12	7.0	32.0	1.5	32.5	22
ST21593 - 06 - 16	10	3/8	- 06	M16X1.5	10	5.5	35.5	1.5	40.0	19
ST21593 - 06 - 18	10	3/8	- 06	M18X1.5	12	7.0	36.5	1.5	33.5	22
ST21593 - 06 - 22	10	3/8	- 06	M22X1.5	15	9.5	36.5	2.5	35.0	27
ST21592 - 08 - 18	12	1/2	- 08	M18X1.5	12	7.0	44.0	1.0	48.0	22
ST21593 - 08 - 22	12	3/4	- 08	M22X1.5	15	9.5	45.0	2.5	39.5	27
ST21593 - 08 - 26	12	3/4	- 08	M26X1.5	18	12.0	45.0	2.5	40.0	32
ST21592 - 10 - 22	16	5/8	- 10	M22X1.5	15	10.0	53.5	2.5	57.5	27
ST21593 - 10 - 30	16	1	- 10	M30X2.0	22	15.0	51.5	4.0	54.0	36
ST21593 - 12 - 30	19	3/4	- 12	M30X2.0	22	15.0	61.5	4.0	59.0	36
ST21593 - 16 - 36	25	1	- 16	M36X2.0	28	20.0	76.5	4.0	41.0	41
ST21593 - 20 - 45	31	1.1/4	- 20	M45X2.0	35	25.0	93.5	5.0	81.0	50
ST21593 - 24 - 52	38	1.1/2	- 24	M52X2.0	42	32.0	107.5	5.5	98.0	60

ST21612/ST21613

(DIN20066/ISO 12151-2)

O'RING METRIC FEMALE 24° CONE SEAT

STRONG TYPE HEAVY DUTY

[THRUST WIRE/SLIP-ON NUT]

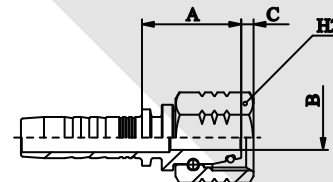

PART. REF.	HOSE BORE			THREAD	PIPE	DIMENSIONS				
	DN	INCH	SIZE	HT.METRIC	MM	B	A	C		H2
ST21613 - 03 - 16	5	3/16	- 03	M16X1.5	8	3.2	21.9	3.4		19
ST21613 - 04 - 14	6	1/4	- 04	M14X1.5	6	2.5	23.5	1.5		17
ST21613 - 04 - 16	6	1/4	- 04	M16X1.5	8	4.1	22.2	1.5		19
ST21613 - 04 - 18	6	1/4	- 04	M18X1.5	10	4.1	28.0	1.0		22
ST21613 - 04 - 20	6	1/4	- 04	M20X1.5	12	8.0	25.7	2.5		24
ST21613 - 05 - 18	8	5/16	- 05	M18X1.5	10	5.5	28.0	3.0		22
ST21613 - 05 - 20	8	5/16	- 05	M20X1.5	12	5.5	24.8	2.5		24
ST21613 - 06 - 18	10	3/8	- 06	M18X1.5	10	5.0	28.5	1.0		22
ST21613 - 06 - 20	10	3/8	- 06	M20X1.5	12	7.0	25.3	2.5		24
ST21613 - 06 - 22	10	3/8	- 06	M22X1.5	14	7.0	32.6	2.5		27
ST21613 - 08 - 22	12	1/2	- 08	M22X1.5	14	9.5	27.5	2.5		27
ST21613 - 08 - 24	12	1/2	- 08	M24X1.5	16	9.5	26.7	3.0		30
ST21613 - 10 - 30	16	5/8	- 10	M30X2.0	20	12.0	30.6	3.5		36
ST21612 - 12 - 30	19	3/4	- 12	M30X2.0	20	15.0	33.5	3.5		36
ST21613 - 12 - 36	19	3/4	- 12	M36X2.0	25	15.0	32.5	5.0		46
ST21612 - 16 - 36	25	1	- 16	M36X2.0	25	20.0	35.3	5.0		46
ST21613 - 16 - 42	25	1	- 16	M42X2.0	30	20.0	35.4	5.0		46
ST21613 - 16 - 52	25	1	- 16	M52X2.0	38	*	*	*		*
ST21613 - 20 - 52	31	1.1/4	- 20	M52X2.0	38	25.0	37.5	6.5		60
ST21613 - 24 - 52	38	1.1/2	- 24	M52X2.0	38	32.0	49.6	6.5		60

ST21642/ST21643

(DIN20066/ISO 12151-2)

45° O'RING METRIC FEMALE 24° CONE SEAT

STRONG TYPE HEAVY DUTY

[THRUST WIRE/SLIP-ON NUT]

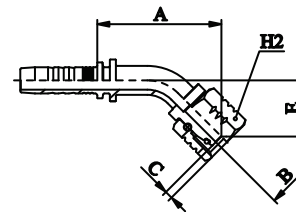

PART. REF.	HOSE BORE			THREAD	PIPE	DIMENSIONS				
	DN	INCH	SIZE	HT.METRIC	MM	B	A	C	E	H2
ST21643 - 04 - 16	6	1/4	- 04	M16X1.5	8	4.1	36.0	1.5	15.0	19
ST21643 - 04 - 18	6	1/4	- 04	M18X1.5	10	4.1	37.5	1.0	16.5	22
ST21643 - 05 - 20	8	5/16	- 05	M20X1.5	12	5.5	42.5	2.5	18.5	24
ST21643 - 06 - 20	10	3/8	- 06	M20X1.5	12	7.0	45.0	2.5	18.0	24
ST21643 - 06 - 22	10	3/8	- 06	M22X1.5	14	7.0	46.5	2.5	19.5	27
ST21643 - 08 - 24	12	1/2	- 08	M24X1.5	16	9.5	52.5	3.0	20.0	30
ST21643 - 10 - 30	16	5/8	- 10	M30X2.0	20	15.0	65.5	3.5	29.5	36
ST21642 - 12 - 30	19	3/4	- 12	M30X2.0	20	15.0	76.5	3.5	34.0	36
ST21643 - 12 - 36	19	3/4	- 12	M36X2.0	25	15.0	75.0	5.0	32.5	41
ST21643 - 16 - 42	25	1	- 16	M42X2.0	30	20.0	90.0	5.0	35.5	50
ST21643 - 20 - 52	31	1.1/4	- 20	M52X2.0	38	25.0	103.0	6.5	39.5	60

ST21692/ST21693

(DIN20066/ISO 12151-2)

90° O'RING METRIC FEMALE 24° CONE SEAT
STRONG TYPE HEAVY DUTY
[THRUST WIRE/SLIP-ON NUT]

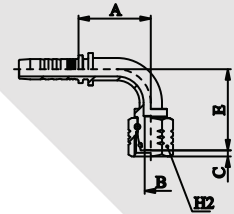

PART. REF.	HOSE BORE			THREAD	PIPE	DIMENSIONS				
	DN	INCH	SIZE	HT.METRIC	MM	B	A	C	E	H2
ST21693 - 04 - 14	6	1/4	- 04	M14X1.5	6	2.5	29.5	1.5	32.5	17
ST21693 - 04 - 16	6	1/4	- 04	M16X1.5	8	4.1	29.5	1.5	29.5	19
ST21693 - 04 - 18	6	1/4	- 04	M18X1.5	10	4.1	29.5	1.0	31.0	22
ST21693 - 04 - 20	6	1/4	- 04	M20X1.5	12	8.0	29.5	2.0	34.5	24
ST21693 - 05 - 20	8	5/16	- 05	M20X1.5	12	5.5	32.0	2.5	34.0	24
ST21693 - 06 - 20	10	3/8	- 06	M20X1.5	12	7.0	36.5	2.5	35.0	24
ST21693 - 06 - 22	10	3/8	- 06	M22X1.5	14	7.0	36.5	2.5	37.0	27
ST21693 - 06 - 24	10	3/8	- 06	M24X1.5	16	10.0	36.5	3.0	36.0	30
ST21693 - 08 - 22	12	1/2	- 08	M22X1.5	14	9.5	44.0	2.5	48.5	27
ST21693 - 08 - 24	12	1/2	- 08	M24X1.5	16	9.5	45.0	3.0	40.5	30
ST21693 - 10 - 30	16	5/8	- 10	M30X2.0	20	12.0	51.5	3.5	57.5	36
ST21692 - 12 - 30	19	3/4	- 12	M30X2.0	20	15.0	61.5	3.5	67.5	36
ST21693 - 12 - 36	19	3/4	- 12	M36X2.0	25	15.0	61.5	5.0	64.5	41
ST21692 - 16 - 36	25	1	- 16	M36X2.0	25	20.0	79.5	5.0	68.0	46
ST21693 - 16 - 42	25	1	- 16	M42X2.0	30	20.0	79.0	5.0	74.5	50
ST21693 - 20 - 52	31	1.1/4	- 20	M52X2.0	38	25.0	93.5	6.5	85.5	60

ST21713

[THRUST WIRE/SLIP-ON NUT]

FRENCH METRIC FEMALE MILLIMETRIC
MILLIMETRIC TYPE

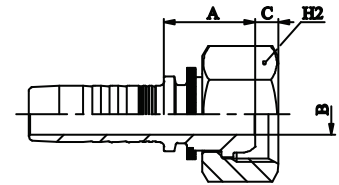

PART. REF.	HOSE BORE			THREAD	PIPE	DIMENSIONS				
	DN	INCH	SIZE	FR.METRIC	MM	B	A	C	H2	
ST21713 - 10 - 2718	16	5/8	- 10	M27X1.5	18	12.5	22.2	5.1		32
ST21713 - 10 - 2720	16	5/8	- 10	M27X1.5	20	12.5	22.2	5.1		32
ST21713 - 12 - 30	19	3/4	- 12	M30X1.5	22	15.0	25.5	4.1		36
ST21713 - 12 - 33	19	3/4	- 12	M33X1.5	25	15.0	25.5	4.1		38
ST21713 - 16 - 36	25	1	- 16	M36X1.5	28	19.8	27.8	4.8		41
ST21713 - 16 - 39	25	1	- 16	M39X1.5	30	19.8	28.3	4.3		46

ST21813

[THRUST WIRE]

FRENCH METRIC FEMALE
GAZ TYPE

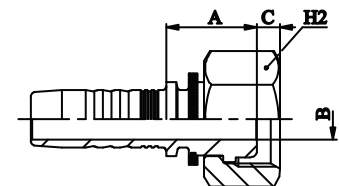

PART. REF.	HOSE BORE			THREAD	PIPE	DIMENSIONS				
	DN	INCH	SIZE	FR.METRIC	MM	B	A	C	H2	
ST21813 - 04 - 20	6	1/4	- 04	M20X1.5	13.25	7.0	22.1	4.3		24
ST21813 - 06 - 20	10	3/8	- 06	M20X1.5	13.25	7.0	22.6	4.3		24
ST21813 - 06 - 24	10	3/8	- 06	M24X1.5	16.75	9.3	25.6	4.0		30
ST21813 - 08 - 24	12	1/2	- 08	M24X1.5	16.75	9.3	26.5	4.0		30
ST21813 - 08 - 30	12	1/2	- 08	M30X1.5	21.25	12.5	23.6	5.1		36
ST21813 - 10 - 30	16	5/8	- 10	M30X1.5	21.25	12.5	23.7	5.1		36
ST21813 - 12 - 36	19	3/4	- 12	M36X1.5	26.75	15.0	27.0	4.8		41
ST21813 - 16 - 45	25	1	- 16	M45X1.5	33.5	19.8	26.8	4.6		50

ST21893

[THRUST WIRE]

90° FRENCH METRIC FEMALE
GAZ TYPE

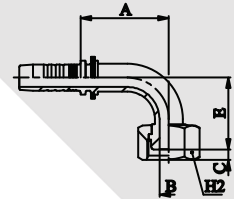

PART. REF.	HOSE BORE			THREAD FR.METRIC	PIPE MM	DIMENSIONS					
	DN	INCH	SIZE			B	A	C	E	H2	
ST21893 - 06 - 20	10	3/8	- 06	M20X1.5	13.25	7.0	36.5	4.3	33.5		24
ST21893 - 08 - 24	12	1/2	- 08	M24X1.5	16.75	12.0	45.0	4.0	41.0		30
ST21893 - 10 - 30	16	5/8	- 10	M30X1.5	21.25	12.5	51.5	5.1	53.5		36
ST21893 - 12 - 36	19	3/4	- 12	M36X1.5	26.75	15.0	61.5	4.8	60.0		41

ST22010

(DIN2353/ISO 8434-1)

METRIC STANDPIPE STRAIGHT

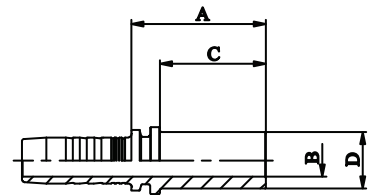

PART. REF.	HOSE BORE			DIMENSIONS	B	A	C	D
	DN	INCH	SIZE					
ST22010 - 03 - 06	5	3/16	- 03		3.1	28.6	22.0	6.0
ST22010 - 03 - 08	5	3/16	- 03		3.0	30.6	24.0	8.0
ST22010 - 04 - 06	6	1/4	- 04		4.1	29.5	20.0	6.0
ST22010 - 04 - 08	6	1/4	- 04		4.1	31.5	24.0	8.0
ST22010 - 04 - 10	6	1/4	- 04		4.1	33.5	26.0	10.0
ST22010 - 04 - 12	6	1/4	- 04		7.0	33.5	26.0	12.0
ST22010 - 05 - 10	8	5/16	- 05		7.0	30.5	23.0	10.0
ST22010 - 05 - 12	8	5/16	- 05		7.0	33.5	26.0	12.0
ST22010 - 06 - 10	10	3/8	- 06		7.0	30.6	20.0	10.0
ST22010 - 06 - 12	10	3/8	- 06		7.0	30.6	23.0	12.0
ST22010 - 06 - 14	10	3/8	- 06		8.0	36.6	29.0	14.0
ST22010 - 08 - 12	12	1/2	- 08		9.5	30.9	21.0	12.0
ST22010 - 08 - 14	12	1/2	- 08		9.3	36.9	29.0	14.0
ST22010 - 08 - 15	12	1/2	- 08		9.5	32.9	24.0	15.0
ST22010 - 08 - 16	12	1/2	- 08		9.5	37.9	29.0	16.0
ST22010 - 08 - 18	12	1/2	- 08		9.5	33.9	25.0	18.0
ST22010 - 10 - 18	16	5/8	- 10		12.5	34.2	26.0	18.0
ST22010 - 10 - 20	16	5/8	- 10		12.5	44.2	36.0	20.0
ST22010 - 10 - 22	16	5/8	- 10		15.0	36.2	28.0	22.0
ST22010 - 12 - 18	19	3/4	- 12		15.0	36.2	24.0	18.0
ST22010 - 12 - 20	19	3/4	- 12		15.0	46.0	36.0	20.0
ST22010 - 12 - 22	19	3/4	- 12		15.0	38.0	28.0	22.0
ST22010 - 12 - 25	19	3/4	- 12		15.0	50.0	40.0	25.0
ST22010 - 16 - 25	25	1	- 16		20.0	53.0	40.0	25.0
ST22010 - 16 - 28	25	1	- 16		20.0	41.3	30.0	28.0
ST22010 - 16 - 30	25	1	- 16		20.0	55.3	44.0	30.0
ST22010 - 16 - 38	25	1	- 16		26.0	61.3	50.0	38.0
ST22010 - 20 - 30	31	1.1/4	- 20		20.5	56.5	44.0	30.0
ST22010 - 20 - 35	31	1.1/4	- 20		25.0	48.5	36.0	35.0
ST22010 - 20 - 38	31	1.1/4	- 20		26.0	62.5	50.0	38.0
ST22010 - 24 - 38	38	1.1/2	- 24		26.0	62.6	50.0	38.0
ST22010 - 24 - 42	38	1.1/2	- 24		32.0	52.6	40.0	42.0

ST22040
(DIN2353/ISO 8434-1)
45° METRIC STANDPIPE

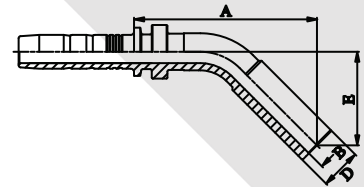

PART. REF.	HOSE BORE			DIMENSIONS					
	DN	INCH	SIZE	B	A	D	E		
ST22040 - 04 - 06	6	1/4	- 04	4.1	45.5	6.0	24.0		
ST22040 - 04 - 08	6	1/4	- 04	4.1	49.0	8.0	27.0		
ST22040 - 04 - 10	6	1/4	- 04	6.0	44.0	10.0	24.0		
ST22040 - 05 - 10	8	5/16	- 05	7.0	44.5	10.0	22.5		
ST22040 - 06 - 10	10	3/8	- 06	7.0	51.0	10.0	26.5		
ST22040 - 06 - 12	10	3/8	- 06	8.0	49.5	12.0	25.0		
ST22040 - 06 - 14	10	3/8	- 06	9.3	54.5	14.0	29.0		
ST22040 - 08 - 14	12	1/2	- 08	*	*	*	*		
ST22040 - 08 - 15	12	1/2	- 08	9.5	59.4	15.0	29.4		
ST22040 - 08 - 16	12	1/2	- 08	9.5	66.0	16.0	35.0		
ST22040 - 10 - 18	16	5/8	- 10	12.0	63.5	18.0	30.5		
ST22040 - 10 - 20	16	5/8	- 10	12.0	85.0	20.0	40.0		
ST22040 - 12 - 22	19	3/4	- 12	15.0	76.0	22.0	32.0		
ST22040 - 12 - 25	19	3/4	- 12	15.0	91.4	25.0	46.9		
ST22040 - 16 - 25	25	1	- 16	15.0	82.0	25.0	41.0		
ST22040 - 16 - 28	25	1	- 16	20.0	95.0	28.0	42.0		

ST22090
(DIN2353/ISO 8434-1)
90° METRIC STANDPIPE

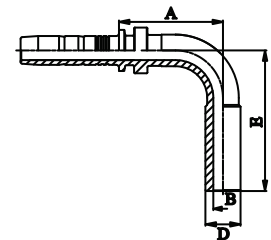

PART. REF.	HOSE BORE			DIMENSIONS					
	DN	INCH	SIZE	B	A	D	E		
ST22090 - 04 - 06	6	1/4	- 04	4.1	27.0	6.0	40.0		
ST22090 - 04 - 08	6	1/4	- 04	4.1	29.0	8.0	43.0		
ST22090 - 04 - 10	6	1/4	- 04	6.0	27.0	10.0	41.0		
ST22090 - 05 - 12	8	5/16	- 05	5.5	33.5	12.0	44.0		
ST22090 - 06 - 10	10	3/8	- 06	7.0	34.0	10.0	47.5		
ST22090 - 06 - 12	10	3/8	- 06	7.0	34.0	12.0	49.0		
ST22090 - 06 - 14	10	3/8	- 06	9.3	42.0	14.0	53.5		
ST22090 - 08 - 14	12	1/2	- 08	9.5	42.0	14.0	53.5		
ST22090 - 08 - 15	12	1/2	- 08	10.5	42.0	15.0	52.0		
ST22090 - 08 - 16	12	1/2	- 08	10.5	43.0	16.0	55.0		
ST22090 - 08 - 18	12	1/2	- 08	9.5	48.5	18.0	58.0		
ST22090 - 10 - 18	16	5/8	- 10	12.5	49.0	18.0	59.0		
ST22090 - 10 - 20	16	5/8	- 10	12.5	49.0	20.0	66.5		
ST22090 - 10 - 22	16	5/8	- 10	12.0	55.0	20.0	72.0		
ST22090 - 12 - 20	19	3/4	- 12	15.0	54.5	20.0	69.0		
ST22090 - 12 - 22	19	3/4	- 12	15.0	54.5	22.0	63.0		
ST22090 - 12 - 25	19	3/4	- 12	15.0	60.0	25.0	80.0		
ST22090 - 16 - 25	25	1	- 16	20.0	70.0	25.0	90.0		
ST22090 - 16 - 28	25	1	- 16	19.8	67.5	28.0	75.0		
ST22090 - 16 - 30	25	1	- 16	20.0	72.5	30.0	95.0		
ST22090 - 20 - 35	31	1.1/4	- 20	26.0	80.5	35.0	94.0		

ST11310

SAE FLARELESS MALE ASSEMBLY

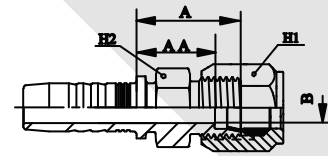

PART. REF.	HOSE BORE			THREAD	DIMENSIONS					
	DN	INCH	SIZE	ERMETO	B	A	TUBE	AA	H1	H2
ST11310 - 04 - 04	6	1/4	- 04	7/16 - 20	4.1	27.0	1/4	20.9	14.3	12
ST11310 - 04 - 05	6	1/4	- 04	1/2 - 20	6.0	24.0	5/16	17.5	15.9	14
ST11310 - 06 - 04	10	3/8	- 06	7/16 - 20	4.0	27.1	1/4	21.0	14.3	17
ST11310 - 06 - 05	10	3/8	- 06	1/2 - 20	6.0	27.1	5/16	20.6	15.9	17
ST11310 - 06 - 06	10	3/8	- 06	9/16 - 18	7.0	28.1	3/8	21.6	17.5	17
ST11310 - 06 - 08	10	3/8	- 06	3/4 - 16	10.0	33.1	1/2	25.2	22.0	22
ST11310 - 08 - 08	12	1/2	- 08	3/4 - 16	9.5	33.0	1/2	25.1	22.0	22
ST11310 - 08 - 10	12	1/2	- 08	7/8 - 14	12.5	34.5	5/8	25.5	25.4	22
ST11310 - 12 - 12	19	3/4	- 12	1.1/16 - 12	15.0	39.0	3/4	30.0	31.8	32

ST12610

(SAE J516/J512)

SAE MALE 45° CONE SEAT

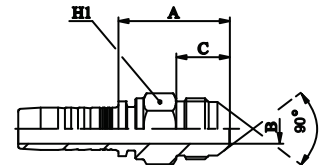

PART. REF.	HOSE BORE			THREAD	DIMENSIONS					
	DN	INCH	SIZE	SAE 45°	B	A	C			H1
ST12610 - 06 - 06	10	3/8	- 06	5/8 - 18	7.0	29.6	14.0			17
ST12610 - 12 - 12	19	3/4	- 12	1.1/16 - 14	15.0	44.0	22.0			27

ST12910

(DIN20066/3865)

STRAIGHT MALE INVERTED FLARE

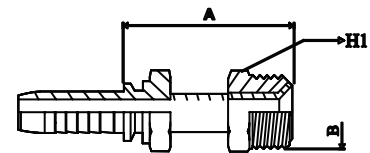

PART. REF.	HOSE BORE			THREAD	DIMENSIONS					
	DN	INCH	SIZE	INVERTED	B	T	TUBE			H1
ST12910 - 04 - 04	6	1/4	- 04	7/16 - 24	4.1	43.5	1/4			12
ST12910 - 04 - 05	6	1/4	- 04	1/2 - 20	4.1	46.0	5/16			14
ST12910 - 05 - 04	8	5/16	- 05	7/16 - 24	5.5	45.0	1/4			12
ST12910 - 06 - 05	10	3/8	- 06	1/2 - 20	7.0	48.0	5/16			14
ST12910 - 06 - 06	10	3/8	- 06	5/8 - 18	7.0	50.0	3/8			17
ST12910 - 08 - 08	12	1/2	- 08	3/4 - 18	9.5	51.0	1/2			19

ST12940
 (SAE J516/J512)
 45° MALE INVERTED FLARE

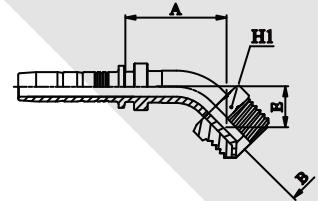

PART. REF.	HOSE BORE			THREAD	DIMENSIONS					
	DN	INCH	SIZE	INVERTED	B	A	TUBE	E		H1
ST12940 - 04 - 04	6	1/4	- 04	7/16 - 24	3.8	72.57	1/4	31.5		12
ST12940 - 04 - 05	6	1/4	- 04	1/2 - 20	4.64	75.0	5/16	40.0		14
ST12940 - 05 - 06	8	5/16	- 05	5/8 - 18	6.22	76.0	3/8	38.0		17
ST12940 - 06 - 04	10	3/8	- 06	7/16 - 24	3.86	68.0	1/4	32.0		12
ST12940 - 06 - 05	10	3/8	- 06	1/2 - 20	4.64	70.7	5/16	40.0		14
ST12940 - 06 - 06	10	3/8	- 06	5/8 - 18	6.22	76.0	3/8	38.0		17
ST12940 - 08 - 08	12	1/2	- 08	3/4 - 18	9.5	85.0	1/2	46.0		19

ST12990
 (SAE J516/J512)
 90° MALE INVERTED FLARE

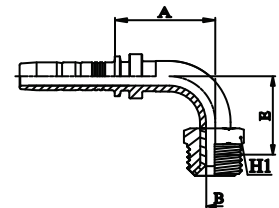

PART. REF.	HOSE BORE			THREAD	DIMENSIONS					
	DN	INCH	SIZE	INVERTED	B	A	TUBE	E		H1
ST12990 - 04 - 04	6	1/4	- 04	7/16 - 24	3.86	40.0	1/4	52.0		12
ST12990 - 04 - 05	6	1/4	- 04	1/2 - 20	4.64	38.0	5/16	55.0		14
ST12990 - 05 - 06	8	5/16	- 05	5/8 - 18	5.5	40.0	3/8	62.0		17
ST12990 - 06 - 04	10	3/8	- 06	7/16 - 24	3.86	40.0	1/4	57.0		12
ST12990 - 06 - 05	10	3/8	- 06	1/2 - 20	4.64	40.0	5/16	62.0		14
ST12990 - 06 - 06	10	3/8	- 06	5/8 - 18	6.22	40.0	3/8	62.0		17
ST12990 - 08 - 08	12	1/2	- 08	3/4 - 18	9.5	54.0	1/2	65.0		19

ST22612
 (DIN 20066/3865)[THRUST WIRE]
 SAE FEMALE STRAIGHT 45° FLARE

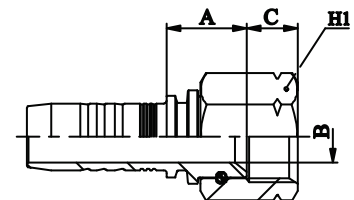

PART. REF.	HOSE BORE			THREAD	DIMENSIONS					
	DN	INCH	SIZE	SAE 45°	B	A	C			H1
ST22612 - 06 - 06	10	3/8	- 06	5/8 - 18	7.0	16.6	10.8			22
ST22612 - 12 - 12	19	3/4	- 12	1.1/16 - 14	15.0	23.0	14.4			32

ST22642

(SAE J516)
SAE FEMALE 45° FLARE
[THRUST WIRE]

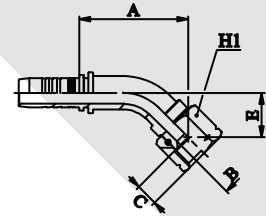

PART. REF.	HOSE BORE			THREAD	DIMENSIONS					
	DN	INCH	SIZE	SAE 45°	B	A	C	E		H1
ST22642 - 06 - 06	10	3/8	- 06	5/8 - 18	7.0	42.0		16.5		22

ST22692

(SAE J516)
SAE FEMALE 90° FLARE
[THRUST WIRE]

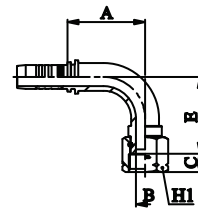

PART. REF.	HOSE BORE			THREAD	DIMENSIONS					
	DN	INCH	SIZE	SAE 45°	B	A	C	E		H1
ST22692 - 06 - 06	10	3/8	06	5/8 - 18	7.0	35.5	10.8	33.0		22
ST22692 - 12 - 12	19	3/4	12	1.1/16 - 14	15.0	62.0	14.4	58.0		32

ST23811

(JIS B 8363)[CRIMP BACK]

FEMALE STRAIGHT "JIS" BSP STYLE 60° CONE SEAT (TOYOTA)

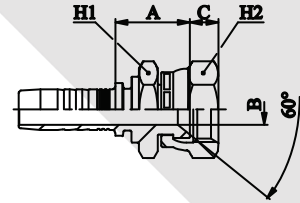

PART. REF.	HOSE BORE			THREAD	DIMENSIONS					
	DN	INCH	SIZE	JIS	B	A	C	H1	H2	
ST23811 - 04 - 04	6	1/4	- 04	1/4 - 19	4.1	21.5	8.3	19	19	
ST23811 - 06 - 06	10	3/8	- 06	3/8 - 19	7	23.1	10	22	22	
ST23811 - 08 - 08	12	1/2	- 08	1/2 - 14	9.5	27	11.5	27	27	
ST23811 - 10 - 10	16	5/8	- 10	5/8 - 14	15	30	13.6	32	32	
ST23811 - 12 - 12	19	3/4	- 12	3/4 - 14	15	30	13.6	32	32	
ST23811 - 16 - 16	25	1	- 16	1 - 11	20	35	15.5	38	38	

ST23891

(JIS B 8363)[CRIMP BACK]

FEMALE 90° "JIS" BSP STYLE 60° CONE SEAT (TOYOTA)

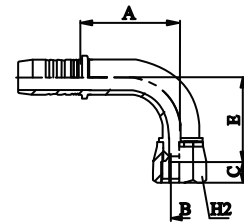

PART. REF.	HOSE BORE			THREAD	DIMENSIONS					
	DN	INCH	SIZE	JIS	B	A	C	E	H1	
ST23891 - 04 - 04	6	1/4	- 04	1/4 - 19	4.1	32	8.3	27	19	
ST23891 - 06 - 06	10	3/8	- 06	3/8 - 19	7	37	10	38	22	
ST23891 - 08 - 08	12	1/2	- 08	1/2 - 14	9.5	47.5	11.5	40	27	
ST23891 - 12 - 12	19	3/4	- 12	3/4 - 14	15	61	13.6	58.4	32	

ST24011

(JIS B 8363)[CRIMP BACK]

JIS METRIC FEMALE 60° CONE SEAT (KOMATSU)

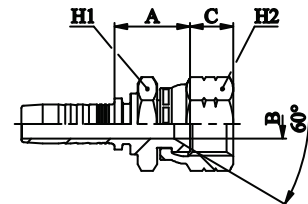

PART. REF.	HOSE BORE			THREAD	DIMENSIONS					
	DN	INCH	SIZE	JIS	B	A	C	H1	H2	
ST24011 - 04 - 14	6	1/4	- 04	M14X1.5	4.1	23	10.5	19	19	
ST24011 - 04 - 18	6	1/4	- 04	M18X1.5	4.1	25	11.5	24	24	
ST24011 - 05 - 16	8	5/16	- 05	M16X1.5	5.5	24	10.5	22	22	
ST24011 - 06 - 14	10	3/8	- 06	M14X1.5	7	23.3	10.5	19	19	
ST24011 - 06 - 18	10	3/8	- 06	M18X1.5	7	25	11.5	24	24	
ST24011 - 08 - 22	12	1/2	- 08	M22X1.5	9.5	27.7	14	27	27	
ST24011 - 10 - 24	16	5/8	- 10	M24X1.5	12	30.5	15	32	32	
ST24011 - 12 - 30	19	3/4	- 12	M30X1.5	15	31.3	18	36	36	
ST24011 - 16 - 33	25	1	- 16	M33X1.5	*	*	*	*	*	
ST24011 - 20 - 36	31	1.1/4	- 20	M36X1.5	25	37	20	46	46	
ST24012 - 24 - 42	38	1.1/2	- 24	M42X1.5	32	40	18.8	55	55	

ST24041**(JIS B 8363)[CRIMP BACK]**

45° JIS METRIC FEMALE 60° CONE SEAT (KOMATSU)

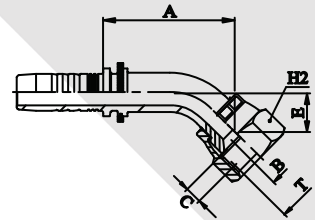

PART. REF.	HOSE BORE			THREAD	DIMENSIONS					
	DN	INCH	SIZE	JIS	B	A	C			H2
ST24041 - 04 - 14	6	1/4	- 04	14X1.5	*	*	*			*
ST24041 - 04 - 18	6	1/4	- 04	18X1.5	*	*	*			*
ST24041 - 06 - 18	10	3/8	- 06	18X1.5	*	*	*			*
ST24041 - 08 - 22	12	1/2	- 08	22X1.5	*	*	*			*
ST24041 - 08 - 24	12	1/2	- 08	24X1.5	*	*	*			*
ST24041 - 10 - 24	16	5/8	- 10	24X1.5	*	*	*			*
ST24041 - 12 - 30	19	3/4	- 12	30X1.5	*	*	*			*

ST24091**(JIS B 8363)[CRIMP BACK]**

90° JIS METRIC FEMALE 60° CONE SEAT (KOMATSU)

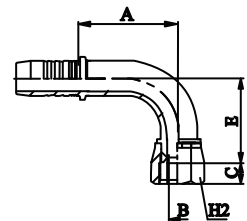

PART. REF.	HOSE BORE			THREAD	DIMENSIONS					
	DN	INCH	SIZE	JIS	B	A	C			H2
ST24091 - 04 - 14	6	1/4	- 04	14X1.5	*	*	*			*
ST24091 - 04 - 16	6	1/4	- 04	16X1.5	*	*	*			*
ST24091 - 04 - 18	6	1/4	- 04	18X1.5	*	*	*			*
ST24091 - 06 - 18	10	3/8	- 06	18X1.5	*	*	*			*
ST24091 - 08 - 22	12	1/2	- 08	22X1.5	*	*	*			*
ST24091 - 10 - 24	16	5/8	- 10	24X1.5	*	*	*			*
ST24091 - 12 - 30	19	3/4	- 12	30X1.5	*	*	*			*

ST12H10

STRAIGHT MALE "EASY PUSH" INSERT

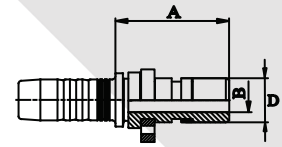

PART. REF.	HOSE BORE			DIMENSIONS					
	DN	INCH	SIZE	B	A	D			
ST12H10 - 04 - 04	6	1/4	- 04	4	30	10			
ST12H10 - 04 - 06	6	1/4	- 04	7	34	13			
ST12H10 - 05 - 06	8	5/16	- 05	7	34	13			
ST12H10 - 06 - 04	10	3/8	- 06	4	30.5	10			
ST12H10 - 06 - 06	10	3/8	- 06	7	34.5	13			
ST12H10 - 06 - 08	10	3/8	- 06	9.3	34.5	16			
ST12H10 - 08 - 06	12	1/2	- 08	7	35	13			
ST12H10 - 08 - 08	12	1/2	- 08	9.3	35	16			
ST12H10 - 10 - 08	16	5/8	- 10	9.3	35	16			

ST12H40

45° MALE "EASY PUSH" INSERT

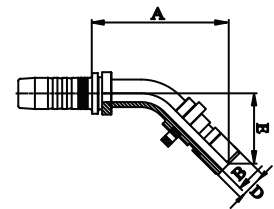

PART. REF.	HOSE BORE			DIMENSIONS					
	DN	INCH	SIZE	B	A	D	E		
ST12H40 - 04 - 04	6	1/4	- 04	4	46	10	23.5		
ST12H40 - 04 - 06	6	1/4	- 04	7	52	13	27		
ST12H40 - 05 - 06	8	5/16	- 05	7	53	13	27.5		
ST12H40 - 06 - 04	10	3/8	- 06	4	47	10	23.5		
ST12H40 - 06 - 06	10	3/8	- 06	7	55.5	13	28		
ST12H40 - 08 - 08	12	1/2	- 08	9.3	61.5	16	30		

ST12H90

90° MALE "EASY PUSH" INSERT

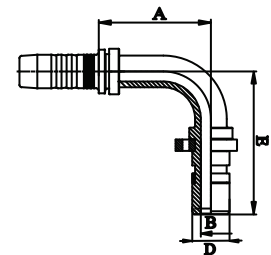

PART. REF.	HOSE BORE			DIMENSIONS					
	DN	INCH	SIZE	B	A	D	E		
ST12H90 - 04 - 04	6	1/4	- 04	4	30	10	40		
ST12H90 - 04 - 06	6	1/4	- 04	7	32	13	45		
ST12H90 - 05 - 06	8	5/16	- 05	7	33.5	13	46.5		
ST12H90 - 06 - 04	10	3/8	- 06	4	30.5	10	40		
ST12H90 - 06 - 06	10	3/8	- 06	7	37	13	49		
ST12H90 - 08 - 08	12	1/2	- 08	9.3	44	16	55		

also available...



TEST POINT

VALVE

**TEST POINT
HOSE & FITTINGS**

- Custom hose assembly
- Bulk hose and fittings
- Variety of threads
- NPT
- JIC
- ORB
- BSP
- ORFS
- METRIC

**PRESSURE
GAUGE**

- Vacuum and pressure
- Bottom & back mount
- Variety of threads
- Back flange available
- 2"1/2 Diameter
(Other size available)
- Glycerine
(Dry type on request)
- 15psi to 10,000psi
(In stock)

**GAUGE PORT
ADAPTER**

- GP5106 (MJ x FJ)
- GP4109
(FORF x MORF)
- 95511TP
(MBSP x FBSP)
- NPT/ORB/BSP
Gauge port threads

**VALVE/PRESSURE
CONTROL**

- Brass low pressure ball valve
- High pressure ball valve
- Multiple threads
NPT/ORB/BSP/DIN
- Carbon steel &
Stainless steel
available
- Check valve (7psi and
65psi cracking)
- Flow control
- Needle valve



**EMBOUTS “ONE-PIECE”
ONE-PIECE HOSE ENDS
2020**



**1-2 WIRE BRAID - SERIE “A” SERIES
2 WIRE BRAID/4 SPIRAL - SERIE “B” SERIES
4/6 SPIRAL - SERIE “C” SERIES
SKIVE IS NO LONGER REQUIRED!**

CRIMPED FITTINGS

A/B

FITTINGS PART NUMBERING SYSTEM

Primary Fitting Series: A/B

- A/B indicates the basic part number.
- 5 digit numbers represent the series or style
- The first dash number represent the hose size.
- The second dash number represents the termination end size
- Part number also contains the basic coupling description.

EXAMPLE

- C is the basic part number.
- 23311 is the series or style of coupling.
- -24 indicates the hose size.
- -20 indicates the termination end size.
- "Flange Straight Head Code 61" is the basic description of the part.

NOTE:

- All coupling are one-piece design.
- All bent stems are made from solid stock (if indicated).
- All code 61 & code 62 flange couplings are made from a single piece of bar stock.

The range of hydraulic couplings conforms to English BS (British Standard), American JIC (Joint Industrial Council), and German DIN/EN (Deutsches Institut für Normung) norms.

Additional items conforming to Japanese norms JIS (Japanese Industrial Standard) are available too.

CRIMPED FITTINGS

FITTINGS - PART NUMBERING SYSTEM

FIRST DIGIT

The numbers stated in this position, refer respectively to the following descriptions:

- 1 = Nuvo ST Type Male
- 2 = Nuvo ST Type Female



SECOND AND THIRD DIGIT

ST DESCRIPTION

- 03 BSP Banjo
- 05 BSP Parallel Thread (60° cone)
- 06 BSP Parallel Thread (Flat face)
- 07 BSP Male Tapered Thread - JIS BSP Female
- 08 BSP Parallel Thread O'Ring (60° cone)
- 09 Metric Banjo
- 10 Metric Thread (60° cone superlight)
- 11 Male Metric Thread (24° cone light type)
- 12 Male Metric Thread (24° cone heavy type)
- 13 Metric Thread (Multiseal cone)
- 15 Female Metric Thread (24° cone O'Ring light type)
- 16 Female Metric Thread (24° cone O'Ring heavy type)
- 17 Metric Thread (French Millimetric)
- 18 Metric Thread (French gaz)
- 20 DIN Metric Standpipe L.T.
- 21 DIN Metric Standpipe H.T.
- 25 JIC Thread (37° cone)
- 27 JIC Thread double hexag. (37° cone)
- 24 ORFS type
- 26 SAE Thread (45° cone)
- 28 NPTF/NPSM Thread
- 30 SAE O'Ring Thread
- 33 Code 61 SAE flange 3000 psi
- 36 Code 62 SAE flange 6000 psi
- 38 JIS (Toyota) Thread
- 39 Supercat flange
- 40 JIS (Komatsu) Thread
- 41 NPTF Swivel Male
- 43 SAE O'Ring Thread Swivel Male
- 44 ORFS Long Drop Elbow
- 47 JIC Thread (37° cone)
- 49 Wash Cleaning Female



FOURTH DIGIT

- | | | |
|-----------------|-----------------|------------------|
| 1 = Straight | 4 = 45° Swept | 8 = Compact type |
| 2 = 22.5° Swept | 6 = 60° Swept | 9 = 90° Swept |
| 3 = 30° Swept | 7 = 67.5° Swept | |



FIFTH DIGIT

- 3 = Slip-on Nut
- 2 = Thurst-wire Nut
- 1 = Crimped-back Nut - flange
- 0 = Male/Ferrule



CRIMPING PARAMETERS

A - TYPE ONE-PIECE COUPLINGS FULL LENGTH FLAT CRIMP: DIE POSITION AFTER CRIMPING

DIE POSITION **AFTER CRIMPING** FOR FULL LENGTH FLAT CRIMP OF ONE-PIECE SERIES COUPLINGS

Coupling must be positioned in the dies in such a way that at the end of crimping stroke, die finger's back edge must align over this Cylindrical Zone of the insert.

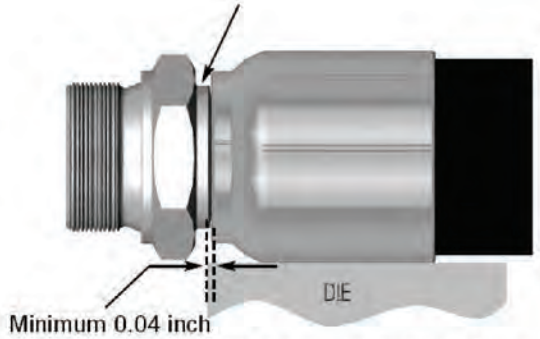

CORRECT DIE POSITION AT THE END OF CRIMPING STROKE

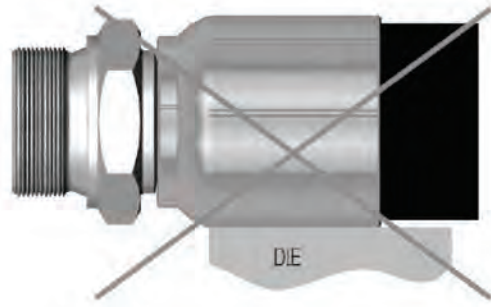

INCORRECT DIE POSITION AT THE END OF CRIMPING STROKE

A-12810

B-12810

(SAE J516)

NPTF MALE 30° CONE SEAT

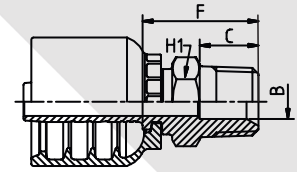

PART. REF. A	PART. REF. B	HOSE BORE			THREAD	DIMENSIONS					
		DN	INCH	SIZE	NPTF	B	F	C	H1		
A-12810 - 03 - 02		5	3/16	- 03	1/8 - 27	3.1	23.6	10.5		12	
A-12810 - 03 - 04		5	3/16	- 03	1/4 - 18	7.0	29.1	15.0		17	
A-12810 - 04 - 02		6	1/4	- 04	1/8 - 27	4.1	24.1	10.5		12	
A-12810 - 04 - 04		6	1/4	- 04	1/4 - 18	4.1	28.8	14.5		14.3	
A-12810 - 04 - 06		6	1/4	- 04	3/8 - 18	8.0	31.9	16.75		19	
A-12810 - 04 - 08		6	1/4	- 04	1/2 - 14	12.5	34.5	19.6		22	
A-12810 - 05 - 04		8	5/16	- 05	1/4 - 18	5.5	30.0	14.5		14.3	
A-12810 - 05 - 06		8	5/16	- 05	3/8 - 18	8.0	31.9	16.0		19	
A-12810 - 06 - 04	B-12810 - 06 - 04	10	3/8	- 06	1/4 - 18	7.0	30.5	14.5		19	
A-12810 - 06 - 06	B-12810 - 06 - 06	10	3/8	- 06	3/8 - 18	9.4	29.0	14.5		19	
A-12810 - 06 - 08	B-12810 - 06 - 08	10	3/8	- 06	1/2 - 14	7.0	34.8	19.3		22	
A-12810 - 08 - 06	B-12810 - 08 - 06	12	1/2	- 08	3/8 - 18	9.5	29.5	14.5		19	
A-12810 - 08 - 08	B-12810 - 08 - 08	12	1/2	- 08	1/2 - 14	9.5	35.2	19.3		22	
A-12810 - 08 - 12	B-12810 - 08 - 12	12	1/2	- 08	3/4 - 14	15.0	35.4	19.5		27	
A-12810 - 10 - 08	B-12810 - 10 - 08	16	5/8	- 10	1/2 - 14	12.0	39.4	19.3		24	
A-12810 - 10 - 12	B-12810 - 10 - 12	16	5/8	- 10	3/4 - 14	15.0	40.2	19.5		27	
A-12810 - 12 - 08	B-12810 - 12 - 08	19	3/4	- 12	1/2 - 14	12.5	37.1	19.3		27	
A-12810 - 12 - 12	B-12810 - 12 - 12	19	3/4	- 12	3/4 - 14	15.0	36.9	19.3		27	
A-12810 - 12 - 16	B-12810 - 12 - 16	19	3/4	- 12	1 - 11.5	15.0	46.0	24.1		36	
A-12810 - 16 - 12	B-12810 - 16 - 12	25	1	- 16	3/4 - 14	15.0	38.8	19.2		32	
A-12810 - 16 - 16	B-12810 - 16 - 16	25	1	- 16	1 - 11.5	19.7	43.7	24.1		36	
A-12810 - 16 - 20	B-12810 - 16 - 20	25	1	- 16	1.1/4 - 11.5	26.0	56.3	25.0		46	
	B-12810 - 20 - 20	31	1.1/4	- 20	1.1/4 - 11.5	25.0	56.4	25.0		46	
	B-12810 - 24 - 24	38	1.1/2	- 24	1.1/2 - 11.5	32.0	57.9	25.5		50	
	B-12810 - 32 - 32	51	2	- 32	2 - 11.5	42.0	64.6	26.0		65	

A-14110

B-14110

(SAE J516)[THRUST WIRE]

NPTF SWIVEL MALE 60° CONE SEAT

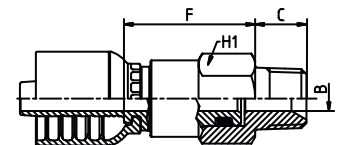

PART. REF. A	PART. REF. B	HOSE BORE			THREAD	DIMENSIONS					
		DN	INCH	SIZE	NPTF	B	F	C	H1		
A-14110 - 04 - 02		6	1/4	- 04	1/8 - 27	4.1	44.3	*		19	
A-14110 - 04 - 04		6	1/4	- 04	1/4 - 18	4.1	42.8	*		19	
A-14110 - 04 - 06		6	1/4	- 04	3/8 - 18	4.1	46.4	19.5		19	
A-14110 - 06 - 04	B-14110 - 06 - 04	10	3/8	- 06	1/4 - 18	7.0	51.4	14.5		19	
A-14110 - 06 - 06	B-14110 - 06 - 06	10	3/8	- 06	3/8 - 18	7.0	48.4	19.5		22	
A-14110 - 06 - 08	B-14110 - 06 - 08	10	3/8	- 06	1/2 - 14	7.0	55.3	27.6		27	
A-14110 - 08 - 06	B-14110 - 08 - 06	12	1/2	- 08	3/8 - 18	7.0	51.5	14.5		27	
A-14110 - 08 - 08	B-14110 - 08 - 08	12	1/2	- 08	1/2 - 14	9.5	55.6	27.6		27	
A-14110 - 12 - 12	B-14110 - 12 - 12	19	3/4	- 12	3/4 - 14	15.0	61.6	27.7		32	
A-14110 - 16 - 16	B-14110 - 16 - 16	25	1	- 16	1 - 11.5	20.0	69.4	32.9		41	

A-14190

B-14190

(SAE J516)

90° NPTF SWIVEL MALE

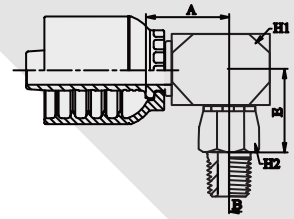

PART. REF. A	PART. REF. B	HOSE BORE			THREAD	DIMENSIONS					
		DN	INCH	SIZE	NPTF						
A-14190 - 04 - 04		6	1/4	- 04	1/4 - 18	*	*	*	*	*	*
A-14190 - 06 - 06	B-14190 - 06 - 06	10	3/8	- 06	3/8 - 18	*	*	*	*	*	*
A-14190 - 08 - 08	B-14190 - 08 - 08	12	1/2	- 08	1/2 - 14	*	*	*	*	*	*
A-14190 - 12 - 12	B-14190 - 12 - 12	19	3/4	- 12	3/4 - 14	*	*	*	*	*	*

A-22812

B-22812

(SAE J516)

NPSM FEMALE 60° CONE SEAT SWIVEL

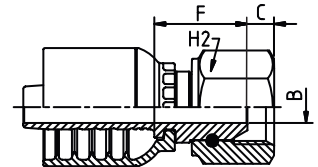

PART. REF. A	PART. REF. B	HOSE BORE			THREAD	DIMENSIONS					
		DN	INCH	SIZE	NPSM	B	F	C			H2
A-22812 - 04 - 04		6	1/4	- 04	1/4 - 18	4.1	22.7	4.2			19
A-22812 - 04 - 06		6	1/4	- 04	3/8 - 18	7.0	18.1	5.5			22
A-22812 - 06 - 04	B-22812 - 06 - 04	10	3/8	- 06	1/4 - 18	7.0	27.0	4.2			19
A-22812 - 06 - 06	B-22812 - 06 - 06	10	3/8	- 06	3/8 - 18	7.0	26.8	6.5			22
A-22812 - 06 - 08	B-22812 - 06 - 08	10	3/8	- 06	1/2 - 14	9.5	23.8	6.5			27
A-22812 - 08 - 08	B-22812 - 08 - 08	12	1/2	- 08	1/2 - 14	9.5	22.2	6.5			27
A-22812 - 12 - 12	B-22812 - 12 - 12	19	3/4	- 12	3/4 - 14	15.0	25.0	9.0			32
A-22812 - 16 - 16	B-22812 - 16 - 16	25	1	- 16	1 - 11.5	20.0	11.0	11.0			38

A-22814

B-22814

(SAE J516)

NPTF FEMALE FIX

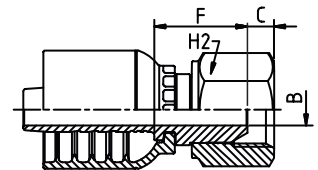

PART. REF. A	PART. REF. B	HOSE BORE			THREAD	DIMENSIONS					
		DN	INCH	SIZE	NPTF	B	F	C			H2
A-22814 - 04 - 02		6	1/4	- 04	1/8 - 27	4.1	13.5	9.0			14
A-22814 - 04 - 04		6	1/4	- 04	1/4 - 18	4.1	16.0	12.0			19
A-22814 - 06 - 04	B-22814 - 06 - 04	10	3/8	- 06	1/4 - 18	7.0	16.3	12.0			19
A-22814 - 06 - 06	B-22814 - 06 - 06	10	3/8	- 06	3/8 - 18	7.0	18.0	12.0			22
A-22814 - 06 - 08	B-22814 - 06 - 08	10	3/8	- 06	1/2 - 14	7.0	16.0	17.0			25.4
A-22814 - 08 - 08	B-22814 - 08 - 08	12	1/2	- 08	1/2 - 14	9.5	18.0	16.0			25.4
A-22814 - 12 - 12	B-22814 - 12 - 12	19	3/4	- 12	3/4 - 14	15.0	23.9	15.1			32
A-22814 - 16 - 16	B-22814 - 16 - 16	25	1	- 16	1 - 11.5	20.0	27.2	17.5			41

A-12510

B-12510

(SAE J516/ISO 12151-5)

JIC MALE 37° CONE SEAT

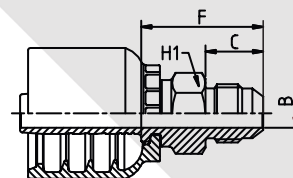

PART. REF. A	PART. REF. B	HOSE BORE			THREAD	DIMENSIONS					
		DN	INCH	SIZE	JIC	B	F	C	H1		
A-12510 - 04 - 04		6	1/4	- 04	7/16 - 20	4.1	28.0	14.0		12	
A-12510 - 04 - 05		6	1/4	- 04	1/2 - 20	4.1	29.0	14.0		14	
A-12510 - 04 - 06		6	1/4	- 04	9/16 - 18	4.1	29.0	14.0		17	
A-12510 - 05 - 05		8	5/16	- 05	1/2 - 20	5.5	29.0	14.0		14	
A-12510 - 05 - 06		8	5/16	- 05	9/16 - 18	5.5	29.0	14.0		17	
A-12510 - 06 - 06	B-12510 - 06 - 06	10	3/8	- 06	6/16 - 18	7.0	29.7	14.0		17	
A-12510 - 06 - 08	B-12510 - 06 - 08	10	3/8	- 06	3/14 - 16	7.0	34.7	16.5		19	
A-12510 - 06 - 10	B-12510 - 06 - 10	10	3/8	- 06	7/8 - 14	7.0	38.6	19.3		24	
A-12510 - 08 - 06	B-12510 - 08 - 06	12	1/2	- 08	9/16 - 18	9.5	32.0	14.0		22	
A-12510 - 08 - 08	B-12510 - 08 - 08	12	1/2	- 08	3/4 - 16	9.5	34.5	16.5		19	
A-12510 - 08 - 10	B-12510 - 08 - 10	12	1/2	- 08	7/8 - 14	9.5	39.2	19.3		24	
A-12510 - 08 - 12	B-12510 - 08 - 12	12	1/2	- 08	1.1/16 - 12	9.5	42.9	21.9		27	
A-12510 - 10 - 10	B-12510 - 10 - 10	16	5/8	- 10	7/8 - 14	12.0	39.2	19.3		24	
A-12510 - 10 - 12	B-12510 - 10 - 12	16	5/8	- 10	1.1/16 - 12	12.0	42.7	21.9		27	
A-12510 - 12 - 10	B-12510 - 12 - 10	19	3/4	- 12	7/8 - 14	15.0	41.5	19.3		27	
A-12510 - 12 - 12	B-12510 - 12 - 12	19	3/4	- 12	1.1/16 - 12	15.0	44.0	21.9		27	
A-12510 - 12 - 14	B-12510 - 12 - 14	19	3/4	- 12	1.3/16 - 12	15.0	44.5	22.6		32	
A-12510 - 12 - 16	B-12510 - 12 - 16	19	3/4	- 12	1.5/16 - 12	15.0	47.0	23.1		34	
A-12510 - 16 - 12	B-12510 - 16 - 12	25	1	- 16	1.1/16 - 12	20.0	44.8	21.9		32	
A-12510 - 16 - 16	B-12510 - 16 - 16	25	1	- 16	1.5/16 - 12	19.7	48.0	23.1		34	
A-12510 - 16 - 20	B-12510 - 16 - 20	25	1	- 16	1.5/8 - 12	20.0	52.8	24.3		46	
	B-12510 - 20 - 20	31	1.1/4	- 20	1.5/8 - 12	25.0	53.5	24.3		46	
	B-12510 - 20 - 24	31	1.1/4	- 20	1.7/8 - 12	25.0	60.5	27.5		50	
	B-12510 - 24 - 24	38	1.1/2	- 24	1.7/8 - 12	32.0	60.5	27.5		50	
	B-12510 - 32 - 32	51	2	- 32	2.1/2 - 12	42.0	71.8	33.9		65	

A-22541

B-22541

(SAE J516/ISO 12151-5)

45° JIC FEMALE 37° CONE SEAT

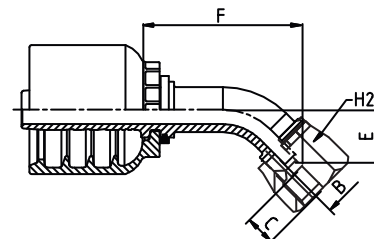

PART. REF. A	PART. REF. B	HOSE BORE			THREAD	DIMENSIONS					
		DN	INCH	SIZE	JIC	B	F	C	E	H1	
A-22541 - 04 - 04		6	1/4	- 04	7/16 - 20	4.1	35.5	9.5	14.5	14.3	
A-22541 - 04 - 05		6	1/4	- 04	1/2 - 20	*	*	*	*	*	
A-22541 - 04 - 06		6	1/4	- 04	9/16 - 18	*	*	*	*	*	
A-22541 - 06 - 06	B-22541 - 06 - 06	10	3/8	- 06	9/16 - 18	7.0	42.0	9.5	16.5	17.5	
A-22541 - 06 - 08	B-22541 - 06 - 08	10	3/8	- 06	3/4 - 16	*	*	*	*	*	
A-22541 - 08 - 08	B-22541 - 08 - 08	12	1/2	- 08	3/4 - 16	9.5	52.0	11.0	20.0	22.0	
A-22541 - 08 - 10	B-22541 - 08 - 10	12	1/2	- 08	7/8 - 14	9.5	49.5	12.0	17.0	25.4	
A-22541 - 10 - 10	B-22541 - 10 - 10	16	5/8	- 10	7/8 - 14	*	*	*	*	*	
A-22541 - 12 - 12	B-22541 - 12 - 12	19	3/4	- 12	1.1/16 - 12	15.0	70.0	14.5	27.5	32.0	
A-22541 - 12 - 16	B-22541 - 12 - 16	19	3/4	- 12	1.5/16 - 12	*	*	*	*	*	
A-22541 - 16 - 16	B-22541 - 16 - 16	25	1	- 16	1.5/16 - 12	*	*	*	*	*	
	B-22541 - 20 - 20	31	1.1/4	- 20	1.5/8 - 12	*	*	*	*	*	

A-22542

B-22542

(SAE J516/ISO 12151-5)

45° JIC FEMALE 37° CONE SEAT

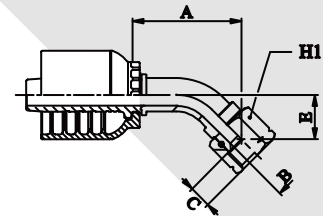

PART. REF. A	PART. REF. B	HOSE BORE			THREAD	DIMENSIONS					
		DN	INCH	SIZE	JIC	B	F	C	E	H1	
A-22542 - 03 - 04		5	3/16	- 03	7/16 - 20	3.1	35.0	9.0	14.5	17	
A-22542 - 04 - 04		6	1/4	- 04	7/16 - 20	4.1	35.5	9.0	14.5	17	
A-22542 - 04 - 05		6	1/4	- 04	1/2 - 20	4.1	35.7	9.5	14.5	17	
A-22542 - 04 - 06		6	1/4	- 04	9/16 - 18	4.1	35.5	9.5	14.0	19	
A-22542 - 05 - 05		8	5/16	- 05	1/2 - 20	5.5	37.5	9.5	14.5	17	
A-22542 - 05 - 06		8	5/16	- 05	9/16 - 18	5.5	38.0	9.5	14.5	19	
A-22542 - 06 - 06	B-22542 - 06 - 06	10	3/8	- 06	6/16 - 18	7.0	42.0	9.5	16.5	19	
A-22542 - 06 - 08	B-22542 - 06 - 08	10	3/8	- 06	3/4 - 16	9.9	45.8	11.0	14.0	22	
A-22542 - 06 - 10	B-22542 - 06 - 10	10	3/8	- 06	7/8 - 14	7.0	42.5	13.0	15.5	27	
A-22542 - 08 - 08	B-22542 - 08 - 08	12	1/2	- 08	3/4 - 16	9.5.0	52.0	11.0	20.0	22	
A-22542 - 08 - 10	B-22542 - 08 - 10	12	1/2	- 08	7/8 - 14	9.5.0	49.5	13.0	17.0	27	
A-22542 - 08 - 12	B-22542 - 08 - 12	12	1/2	- 08	1.1/16 - 12	9.5.0	50.0	14.4	17.0	32	
A-22542 - 10 - 10	B-22542 - 10 - 10	16	5/8	- 10	7/8 - 14	12.0	62.0	25.5	25.5	27	
A-22542 - 10 - 12	B-22542 - 10 - 12	16	5/8	- 10	1.1/16 - 12	12.0	60.0	14.4	24.0	32	
A-22542 - 12 - 12	B-22542 - 12 - 12	19	3/4	- 12	1.1/16 - 12	15.0	70.0	14.4	27.5	32	
A-22542 - 12 - 14	B-22542 - 12 - 14	19	3/4	- 12	1.3/16 - 12	15.0	70.6	15.8	28.2	35.5	
A-22542 - 12 - 16	B-22542 - 12 - 16	19	3/4	- 12	1.5/16 - 12	15.0	68.4	15.6	27.5	38	
A-22542 - 16 - 12	B-22542 - 16 - 12	25	1	- 16	1.1/16 - 12	20.0	72.5	14.4	27.5	32	
A-22542 - 16 - 16	B-22542 - 16 - 16	25	1	- 16	1.5/16 - 12	20.0	86.0	15.6	32.0	38	
A-22542 - 16 - 20	B-22542 - 16 - 20	25	1	- 16	1.5/8 - 12	20.0	90.0	16.0	36.0	50	
	B-22542 - 20 - 20	31	1.1/4	- 20	1.5/8 - 12	25.0	103.5	16.0	41.5	50	
	B-22542 - 20 - 24	31	1.1/4	- 20	1.7/8 - 12	32.0	106.5	18.8	44.5	60	
	B-22542 - 24 - 24	38	1.1/2	- 24	1.7/8 - 12	32.0	119.0	18.3	46.5	60	
	B-22542 - 32 - 32	51	2	- 32	2.1/2 - 12	44.0	163.0	24.0	68.0	75	

A-22582

B-22582

(SAE J516/ISO 12151-5)

90° JIC FEMALE COMPACT ELBOW 37° CONE SEAT

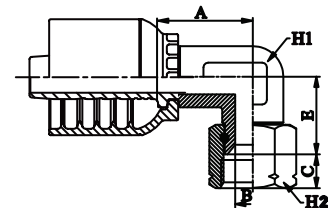

PART. REF. A	PART. REF. B	HOSE BORE			THREAD	DIMENSIONS					
		DN	INCH	SIZE	JIC	B	F	C	E	H1	H2
A-22582 - 04 - 04		5	1/4	- 04	7/16 - 20	4.1	20.0	9.0	20.5	14	17
A-22582 - 04 - 06		5	1/4	- 04	9/16 - 18	4.1	18.5	9.5	21.5	14	19
A-22582 - 06 - 06	B-22582 - 06 - 06	10	3/8	- 06	9/16 - 18	7.0	23.1	9.5	24.0	19	19
A-22582 - 06 - 08	B-22582 - 06 - 08	10	3/8	- 06	3/4 - 16	7.0	26.6	11.0	28.0	22	22
A-22582 - 08 - 08	B-22582 - 08 - 08	12	1/2	- 08	3/4 - 16	9.5	23.0	11.0	28.0	22	22
A-22582 - 08 - 10	B-22582 - 08 - 10	12	1/2	- 08	7/8 - 14	9.5	23.0	13.0	29.0	22	27
A-22582 - 12 - 12	B-22582 - 12 - 12	19	3/4	- 12	1.1/16 - 12	15.0	28.0	14.4	33.0	27	32
A-22582 - 16 - 16	B-22582 - 16 - 16	25	1	- 16	1.5/16 - 12	20.0	30.0	15.6	40.0	36	38

A-22591

B-22591

(SAE J516/ISO 12151-5)

90° JIC FEMALE 37° CONE SEAT

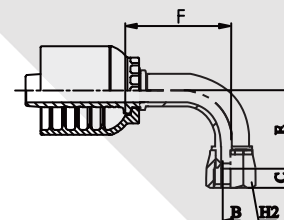

PART. REF. A	PART. REF. B	HOSE BORE			THREAD	DIMENSIONS					
		DN	INCH	SIZE	JIC	B	F	C	E	H2	
A-22591 - 04 - 04		6	1/4	- 04	7/16 - 20	4.1	30.4	9.0	26.0		14.3
A-22591 - 04 - 05		6	1/4	- 04	1/2 - 20	*	*	*	*		*
A-22591 - 04 - 06		6	1/4	- 04	9/16 - 18	4.1	29.5	9.5	28.0		17.5
A-22591 - 05 - 06		8	5/16	- 05	9/16 - 18	*	*	*	*		*
A-22591 - 06 - 06	B-22591 - 06 - 06	10	3/8	- 06	9/16 - 18	7.0	35.5	10.0	32.5		17.5
A-22591 - 06 - 08	B-22591 - 06 - 08	10	3/8	- 06	3/4 - 16	*	*	*	*		*
A-22591 - 08 - 08	B-22591 - 08 - 08	12	1/2	- 08	3/4 - 16	9.5	46.5	11.0	42.0		22.2
A-22591 - 08 - 10	B-22591 - 08 - 10	12	1/2	- 08	7/8 - 14	9.5	45.0	12.0	36.0		25.4
A-22591 - 08 - 12	B-22591 - 08 - 12	12	1/2	- 08	1.1/16 - 12	*	*	*	*		*
A-22591 - 10 - 10	B-22591 - 10 - 10	16	5/8	- 10	7/8 - 14	12.0	53.5	12.0	52.5		25.4
A-22591 - 10 - 12	B-22591 - 10 - 12	16	5/8	- 10	1.1/16 - 12	*	*	*	*		*
A-22591 - 12 - 12	B-22591 - 12 - 12	19	3/4	- 12	1.1/16 - 12	15.0	63.0	14.5	54.0		32
A-22591 - 12 - 16	B-22591 - 12 - 16	19	3/4	- 12	1.5/16 - 12	*	*	*	*		*
A-22591 - 16 - 12	B-22591 - 16 - 12	25	1	- 16	1.1/16 - 12	*	*	*	*		*
A-22591 - 16 - 16	B-22591 - 16 - 16	25	1	- 16	1.5/16 - 12	20.0	77.0	15.7	67.0		38.1
A-22591 - 16 - 20	B-22591 - 16 - 20	25	1	- 16	1.5/8 - 12	*	*	*	*		*
	B-22591 - 20 - 20	31	1.1/4	- 20	1 5/8 - 12	*	*	*	*		*

A-22592

B-22592

(SAE J516/ISO 12151-5)

90° JIC FEMALE 37° CONE SEAT

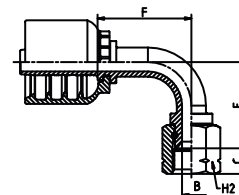

PART. REF. A	PART. REF. B	HOSE BORE			THREAD	DIMENSIONS					
		DN	INCH	SIZE	JIC	B	F	C	E	H1	
A-22592 - 03 - 04		5	3/16	- 03	7/16 - 20	3.1	26.0	9.0	23.5		17
A-22592 - 04 - 04		6	1/4	- 04	7/16 - 20	4.1	28.5	9.0	27.0		17
A-22592 - 04 - 05		6	1/4	- 04	1/2 - 20	4.1	28.5	9.5	27.5		17
A-22592 - 04 - 06		6	1/4	- 04	9/16 - 18	4.1	29.5	9.5	28.0		19
A-22592 - 04 - 08		6	1/4	- 04	3/4 - 16	4.1	29.3	11.0	30.5		22
A-22592 - 05 - 05		8	5/16	- 05	1/2 - 20	5.5	29.5	9.2	27.5		17
A-22592 - 05 - 06		8	5/16	- 05	9/16 - 18	5.5	31.0	9.5	28.5		19
A-22592 - 06 - 06	B-22592 - 06 - 06	10	3/8	- 06	9/16 - 18	7.0	35.5	9.5	32.5		19
A-22592 - 06 - 08	B-22592 - 06 - 08	10	3/8	- 06	3/4 - 16	7.0	36.5	11.0	29.5		22
A-22592 - 06 - 10	B-22592 - 06 - 10	10	3/8	- 06	7/8 - 14	9.3	36.5	12.4	31.5		27
A-22592 - 08 - 06	B-22592 - 08 - 06	12	1/2	- 08	9/16 - 18	9.5	36.5	9.5	33.0		19
A-22592 - 08 - 08	B-22592 - 08 - 08	12	1/2	- 08	3/4 - 16	9.5	44.0	11.0	41.0		22
A-22592 - 08 - 10	B-22592 - 08 - 10	12	1/2	- 08	7/8 - 14	9.5	45.0	13.0	36.0		27
A-22592 - 08 - 12	B-22592 - 08 - 12	12	1/2	- 08	1.1/16 - 12	9.5	45.0	14.4	41.0		32
A-22592 - 10 - 10	B-22592 - 10 - 10	16	5/8	- 10	7/8 - 14	12.0	53.5	13.0	52.5		27
A-22592 - 10 - 12	B-22592 - 10 - 12	16	5/8	- 10	1.1/16 - 12	12.0	51.5	14.4	50.0		32
A-22592 - 12 - 10	B-22592 - 12 - 10	19	3/4	- 12	7/8 - 14	15.0	55.0	13.0	52.5		27
A-22592 - 12 - 12	B-22592 - 12 - 12	19	3/4	- 12	1.1/16 - 12	15.0	62.0	14.4	58.0		32
A-22592 - 12 - 14	B-22592 - 12 - 14	19	3/4	- 12	1.3/16 - 12	15.0	62.0	15.0	58.0		36
A-22592 - 12 - 16	B-22592 - 12 - 16	19	3/4	- 12	1.5/16 - 12	15.0	62.0	15.6	57.5		38
A-22592 - 16 - 16	B-22592 - 16 - 16	25	1	- 16	1.5/16 - 12	20.0	77.0	15.6	67.0		38
A-22592 - 16 - 20	B-22592 - 16 - 20	25	1	- 16	1.5/8 - 12	20.0	77.5	16.0	74.5		50
	B-22592 - 20 - 20	31	1.1/4	- 20	1.5/8 - 12	25.0	90.5	16.0	86.5		50
	B-22592 - 20 - 24	31	1.1/4	- 20	1.7/8 - 12	32.0	90.5	18.8	91.0		60
	B-22592 - 24 - 24	38	1.1/2	- 24	1.7/8 - 12	32.0	108.0	18.3	100.5		60
	B-22592 - 32 - 32	51	2	- 32	2.1/2 - 12	42.0	142.0	23.5	137.0		75

A-22711

B-22711

(SAE J516/J514)[CRIMP BACK]

JIC FEMALE 37° CONE SEAT DOUBLE HEXAGON

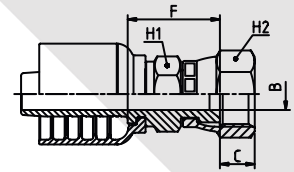

PART. REF. A	PART. REF. B	HOSE BORE			THREAD	DIMENSIONS					
		DN	INCH	SIZE	JIC	B	F	C	H1	H2	
A-22711 - 03 - 04		5	3/16	- 03	7/16 - 20	*	*	*	*	*	
A-22711 - 04 - 04		6	1/4	- 04	7/16 - 20	4.1	20.5	9.0	14	14.3	
A-22711 - 04 - 05		6	1/4	- 04	1/2 - 20	*	*	*	*	*	
A-22711 - 04 - 06		6	1/4	- 04	9/16 - 18	4.1	21.6	9.5	14	17.5	
A-22711 - 06 - 06	B-22711 - 06 - 06	10	3/8	- 06	9/16 - 18	7.0	23.0	10.0	17	17.5	
A-22711 - 06 - 08	B-22711 - 06 - 08	10	3/8	- 06	3/4 - 16	*	*	*	*	*	
A-22711 - 06 - 10	B-22711 - 06 - 10	10	3/8	- 06	7/8 - 14	*	*	*	*	*	
A-22711 - 08 - 06	B-22711 - 08 - 06	12	1/2	- 08	9/16 - 18	7.0	25.1	11.0	17	22.2	
A-22711 - 08 - 08	B-22711 - 08 - 08	12	1/2	- 08	3/4 - 16	9.5	27.7	11.0	19	22.2	
A-22711 - 08 - 10	B-22711 - 08 - 10	12	1/2	- 08	7/8 - 14	9.5	28.7	11.0	22	25.4	
A-22711 - 08 - 12	B-22711 - 08 - 12	12	1/2	- 08	1.1/16 - 12	9.5	29.5	14.2	27	32	
A-22711 - 10 - 08	B-22711 - 10 - 08	16	5/8	- 10	3/4 - 16	12.0	29.5	10.0	22	22	
A-22711 - 10 - 10	B-22711 - 10 - 10	16	5/8	- 10	7/8 - 14	12.0	29.5	12.0	22	25.4	
A-22711 - 10 - 12	B-22711 - 10 - 12	16	5/8	- 10	1.1/16 - 12	15.0	29.0	14.1	27	32	
A-22711 - 12 - 08	B-22711 - 12 - 08	19	3/4	- 12	3/4 - 16	9.3	29.5	10.7	27	22	
A-22711 - 12 - 10	B-22711 - 12 - 10	19	3/4	- 12	7/8 - 14	12.5	30.5	12.5	27	25	
A-22711 - 12 - 12	B-22711 - 12 - 12	19	3/4	- 12	1.1/16 - 12	15.0	31.8	14.5	27	22	
A-22711 - 12 - 16	B-22711 - 12 - 16	19	3/4	- 12	1.5/16 - 12	19.8	34.5	15.3	32	38	
A-22711 - 14 - 16	B-22711 - 14 - 16	*	*	*	1.5/16 - 12	*	*	*	*	*	
A-22711 - 16 - 12	B-22711 - 16 - 12	25	1	- 16	1.1/16 - 12	19.0	33.0	13.4	32	32	
A-22711 - 16 - 16	B-22711 - 16 - 16	25	1	- 16	1.5/16 - 12	19.7	32.9	16.0	32	38.1	
A-22711 - 16 - 20	B-22711 - 16 - 20	25	1	- 16	1.5/8 - 12	*	*	*	*	*	
	B-22711 - 20 - 20	31	1.1/4	- 20	1.5/8 - 12	25.0	42.0	16.0	41	50	

A-22712

B-22712

(SAE J516/ISO 12151-5)

JIC FEMALE 37° CONE SEAT DOUBLE HEXAGON THRUST WIRE

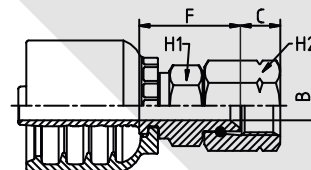

PART. REF. A	PART. REF. B	HOSE BORE			THREAD	DIMENSIONS					
		DN	INCH	SIZE	JIC	B	F	C	H1	H2	
A-22712 - 03 - 04		5	3/16	- 03	7/16 - 20	3.1	20.8	9.0		12	17
A-22712 - 04 - 04		6	1/4	- 04	7/16 - 20	4.1	21.0	9.0		12	17
A-22712 - 04 - 05		6	1/4	- 04	1/2 - 20	4.1	21.5	9.5		12	17
A-22712 - 04 - 06		6	1/4	- 04	9/16 - 18	7.0	23.8	9.5		14	19
A-22712 - 05 - 05		8	5/16	- 05	1/2 - 20	5.5	21.5	9.5		14	17
A-22712 - 05 - 06		8	5/16	- 05	9/16 - 18	5.5	24.9	9.5		14	19
A-22712 - 06 - 04	B-22712 - 06 - 04	10	3/8	- 06	7/16 - 20	7.0	23.8	9.0		17	17
A-22712 - 06 - 05	B-22712 - 06 - 05	10	3/8	- 06	1/2 - 20	7.0	23.8	9.5		17	17
A-22712 - 06 - 06	B-22712 - 06 - 06	10	3/8	- 06	9/16 - 18	7.0	25.3	9.5		17	19
A-22712 - 06 - 08	B-22712 - 06 - 08	10	3/8	- 06	3/4 - 16	7.0	25.3	11.0		19	22
A-22712 - 06 - 10	B-22712 - 06 - 10	10	3/8	- 06	7/8 - 14	7.0	25.8	13.0		22	27
A-22712 - 08 - 06	B-22712 - 08 - 06	12	1/2	- 08	9/16 - 18	9.5	26.2	9.5		19	19
A-22712 - 08 - 08	B-22712 - 08 - 08	12	1/2	- 08	3/4 - 16	9.5	26.2	11.0		19	22
A-22712 - 08 - 10	B-22712 - 08 - 10	12	1/2	- 08	7/8 - 14	9.5	26.7	13.0		22	27
A-22712 - 08 - 12	B-22712 - 08 - 12	12	1/2	- 08	1.1/16 - 12	9.5	30.5	14.4		27	32
A-22712 - 10 - 08	B-22712 - 10 - 08	16	5/8	- 10	3/4 - 16	12.0	27.5	11.0		22	22
A-22712 - 10 - 10	B-22712 - 10 - 10	16	5/8	- 10	7/8 - 14	12.0	29.0	13.0		22	27
A-22712 - 10 - 12	B-22712 - 10 - 12	16	5/8	- 10	1.1/16 - 12	12.0	31.6	14.4		27	32
A-22712 - 12 - 08	B-22712 - 12 - 08	19	3/4	- 12	3/4 - 16	15.0	28.3	11.0		27	22
A-22712 - 12 - 10	B-22712 - 12 - 10	19	3/4	- 12	7/8 - 14	15.0	27.0	13.0		27	27
A-22712 - 12 - 12	B-22712 - 12 - 12	19	3/4	- 12	1.1/16 - 12	15.0	31.5	14.4		24	32
A-22712 - 12 - 14	B-22712 - 12 - 14	19	3/4	- 12	1.3/16 - 12	15.0	34.0	15.0		30	36
A-22712 - 12 - 16	B-22712 - 12 - 16	19	3/4	- 12	1.5/16 - 12	15.0	32.5	15.6		32	38
A-22712 - 16 - 12	B-22712 - 16 - 12	25	1	- 16	1.1/16 - 12	20.0	34.3	14.4		32	32
A-22712 - 16 - 16	B-22712 - 16 - 16	25	1	- 16	1.5/16 - 12	20.0	34.7	15.6		32	38
A-22712 - 16 - 20	B-22712 - 16 - 20	25	1	- 16	1.5/8 - 12	20.0	37.7	16.0		41	50
	B-22712 - 20 - 16	31	1.1/4	- 20	1.5/16 - 12	25.0	36.0	15.6		41	38
	B-22712 - 20 - 20	31	1.1/4	- 20	1.5/8 - 12	25.0	41.0	16.0		41	50
	B-22712 - 24 - 24	38	1.1/2	- 24	1.7/8 - 12	32.0	43.3	18.3		50	60
	B-22712 - 32 - 32	51	2	- 32	2.1/2 - 12	42.0	55.5	23.5		65	75

A-24792

B-24792

(SAE J516/ISO 12151-5)

90° JIC FEMALE LONG DROP ELBOW 37° CONE SEAT THRUST WIRE

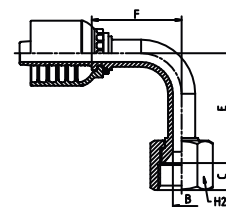

PART. REF. A	PART. REF. B	HOSE BORE			THREAD	DIMENSIONS					
		DN	INCH	SIZE	JIC	B	F	C	E	H2	
A-24792 - 04 - 04		6	1/4	- 04	7/16 - 20	4.1	28.5	9.0	45.0		17
A-24792 - 04 - 06		6	1/4	- 04	9/16 - 18	4.1	29.5	9.5	55.5		19
A-24792 - 06 - 06	B-24792 - 06 - 06	10	3/8	- 06	9/16 - 18	7.0	33.5	9.5	55.0		19
A-24792 - 06 - 08	B-24792 - 06 - 08	10	3/8	- 06	3/4 - 16	7.0	61.5	11.0	61.5		22
A-24792 - 08 - 08	B-24792 - 08 - 08	12	1/2	- 08	3/4 - 16	9.5	40.6	11.0	61.5		22
A-24792 - 08 - 10	B-24792 - 08 - 10	12	1/2	- 08	7/8 - 14	9.5	45.0	13.0	65.0		27
A-24792 - 10 - 10	B-24792 - 10 - 10	16	5/8	- 10	7/8 - 14	12.0	53.5	13.0	65.5		27
A-24792 - 12 - 12	B-24792 - 12 - 12	19	3/4	- 12	1.1/16 - 12	15.0	62.0	14.4	94.5		32
A-24792 - 16 - 16	B-24792 - 16 - 16	25	1	- 16	1.5/16 - 12	20.0	77.0	15.6	110.0		38
	B-24792 - 20 - 20	31	1.1/4	- 20	1.5/8 - 12	25.0	90.5	16.0	129.0		50

A-13010

B-13010

(SAE J516/ISO 11926)

SAE MALE O’RING BOSS TYPE

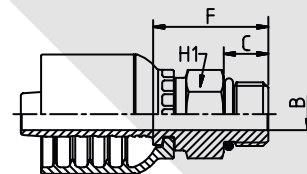

PART. REF. A	PART. REF. B	HOSE BORE			THREAD	DIMENSIONS					
		DN	INCH	SIZE	ORB	B	F	C		H1	
A-13010 - 04 - 04		6	1/4	- 04	7/16 - 20	4.1	23.0	9.1			14
A-13010 - 04 - 05		6	1/4	- 04	1/2 - 20	4.1	23.0	9.1			17
A-13010 - 04 - 06		6	1/4	- 04	9/16 - 18	4.1	24.5	10.0			17
A-13010 - 04 - 08		6	1/4	- 04	3/4 - 16	*	*	*			*
A-13010 - 06 - 06	B-13010 - 06 - 06	10	3/8	- 06	9/16 - 18	7.5	25.5	9.9			17
A-13010 - 06 - 08	B-13010 - 06 - 08	10	3/8	- 06	3/4 - 16	7.0	28.6	11.1			22
A-13010 - 06 - 10	B-13010 - 06 - 10	10	3/8	- 06	7/8 - 14	7.0	31.5	12.7			25
A-13010 - 08 - 08	B-13010 - 08 - 08	12	1/2	- 08	3/4 - 16	9.5	28.9	11.1			22
A-13010 - 08 - 10	B-13010 - 08 - 10	12	1/2	- 08	7/8 - 14	9.5	31.9	12.7			25
A-13010 - 08 - 12	B-13010 - 08 - 12	12	1/2	- 08	1.1/16 - 12	9.5	38.5	15.1			32
A-13010 - 10 - 10	B-13010 - 10 - 10	16	5/8	- 10	7/8 - 14	12.0	32.0	12.7			25
A-13010 - 10 - 12	B-13010 - 10 - 12	10	5/8	- 10	1.1/16 - 12	12.0	37.7	15.1			32
A-13010 - 12 - 10	B-13010 - 12 - 10	19	3/4	- 12	7/8 - 14	*	*	*			*
A-13010 - 12 - 12	B-13010 - 12 - 12	19	3/4	- 12	1.1/16 - 12	15.0	39.5	15.1			32
A-13010 - 12 - 16	B-13010 - 12 - 16	19	3/4	- 12	1.5/16 - 12	15.0	40.1	15.1			38
A-13010 - 16 - 16	B-13010 - 16 - 16	25	1	- 16	1.5/16 - 12	20.0	41.0	15.1			38

A-14310

B-14310

(SAE J516/ISO 11926)

SAE SWIVEL MALE O’RING BOSS TYPE
THRUST WIRE

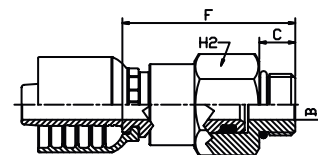

PART. REF. A	PART. REF. B	HOSE BORE			THREAD	DIMENSIONS					
		DN	INCH	SIZE	ORB	B	F			H2	
A-14310 - 04 - 04		6	1/4	- 04	7/16 - 20	4.1	38.8				19
A-14310 - 04 - 06		6	1/4	- 04	9/16 - 18	7.0	44.0				22
A-14310 - 06 - 06	B-14310 - 06 - 06	10	3/8	- 06	9/16 - 18	7.0	44.4				22
A-14310 - 06 - 08	B-14310 - 06 - 08	10	3/8	- 06	3/4 - 16	7.0					27
A-14310 - 08 - 08	B-14310 - 08 - 08	12	1/2	- 08	3/4 - 16	9.5	50.1				27
A-14310 - 08 - 10	B-14310 - 08 - 10	12	1/2	- 08	7/8 - 14	9.5	52.8				27
A-14310 - 08 - 12	B-14310 - 08 - 12	12	1/2	- 08	1.1/16 - 12	9.5	61.2				32
A-14310 - 10 - 10	B-14310 - 10 - 10	16	5/8	- 10	7/8 - 14	12.0	55.8				27
A-14310 - 12 - 12	B-14310 - 12 - 12	19	3/4	- 12	1.1/16 - 12	*	*				*

A-14390

B-14390

(SAE J516/ISO 11926)

90° SWIVEL MALE O’RING BOSS TYPE
THRUST WIRE

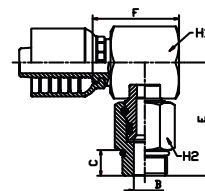

PART. REF. A	PART. REF. B	HOSE BORE			THREAD	DIMENSIONS					
		DN	INCH	SIZE	ORB	B	F	C	E	H1	H2
A-14390 - 06 - 06	B-14390 - 06 - 06	10	3/8	- 06	9/16 - 18	7.0	22.8	15.5	46.5	22	22
A-14390 - 06 - 08	B-14390 - 06 - 08	10	3/8	- 06	3/4 - 16	7.0	22.8	22.1	51.1	22	27
A-14390 - 08 - 08	B-14390 - 08 - 08	12	1/2	- 08	3/4 - 16	9.5	23.0	22.1	51.1	22	27
A-14390 - 08 - 10	B-14390 - 08 - 10	12	1/2	- 08	7/8 - 14	9.5	23.0	24.8	53.8	22	27
A-14390 - 10 - 10	B-14390 - 10 - 10	16	5/8	- 10	7/8 - 14	12.0	28.0	19.1	52.6	27	27
A-14390 - 12 - 12	B-14390 - 12 - 12	19	3/4	- 12	1.1/16 - 12	15.0	30.5	26.2	66.7	32	32

A-12410
B-12410
 (SAE J516/ISO 12151-1)
 MALE ORFS

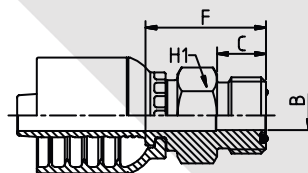

PART. REF. A	PART. REF. B	HOSE BORE			THREAD	DIMENSIONS					
		DN	INCH	SIZE	ORB	B	F	C		H1	
A-12410 - 04 - 04		6	1/4	- 04	9/16 - 18	4.1	24.0	10.0			17
A-12410 - 04 - 06		6	1/4	- 04	11/16 - 16	4.1	26.6	11.0			19
A-12410 - 06 - 06	B-12410 - 06 - 06	10	3/8	- 06	11/16 - 16	7.0	27.6	11.0			19
A-12410 - 06 - 08	B-12410 - 06 - 08	10	3/8	- 06	13/16 - 16	7.0	30.0	13.0			22
A-12410 - 06 - 10	B-12410 - 06 - 10	10	3/8	- 06	1 - 14	*	*	*			*
A-12410 - 08 - 08	B-12410 - 08 - 08	12	1/2	- 08	13/16 - 16	9.5	30.6	13.0			22
A-12410 - 08 - 10	B-12410 - 08 - 10	12	1/2	- 08	1 - 14	9.5	35.0	15.5			27
A-12410 - 10 - 10	B-12410 - 10 - 10	16	5/8	- 10	1 - 14	12.0	34.7	15.5			27
A-12410 - 10 - 12	B-12410 - 10 - 12	16	5/8	- 10	1.3/16 - 12	12.0	37.5	17.0			32
A-12410 - 12 - 12	B-12410 - 12 - 12	19	3/4	- 12	1.3/16 - 12	15.0	39.0	17.0			32
A-12410 - 12 - 16	B-12410 - 12 - 16	19	3/4	- 12	1.7/16 - 12	15.0	40.5	17.5			41
A-12410 - 16 - 16	B-12410 - 16 - 16	25	1	- 16	1.7/16 - 12	20.0	41.8	17.5			41
	B-12410 - 20 - 20	31	1.1/4	- 20	1.11/16 - 12	25.0	46.3	17.5			46
	B-12410 - 24 - 24	38	1.1/2	- 24	2 - 12	32.0	48.6	17.5			55

A-22411/13
B-22411/13
 (SAE J516/ISO 12151-1)[CRIMP BACK/SLIP-ON]
 ORFS FEMALE
 SLIP-ON NUT

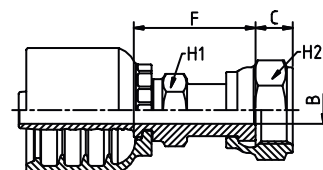

PART. REF. A	PART. REF. B	HOSE BORE			THREAD	DIMENSIONS					
		DN	INCH	SIZE	ORFS	B	F	C		H1	
A-22413 - 03 - 04		5	3/16	- 03	9/16 - 18	3.1	26.6	8.0			17
A-22413 - 04 - 04		5	1/4	- 04	9/16 - 18	4.1	27.5	8.0			17
A-22413 - 04 - 06		6	1/4	- 04	11/16 - 16	4.1	30.0	10.5			22
A-22413 - 05 - 06		8	5/16	- 05	11/16 - 16	7.0	29.6	10.5			22
A-22411 - 06 - 04	B-22411 - 06 - 04	10	3/8	- 06	9/16 - 18	7.0	29.0	8.5			17
A-22413 - 06 - 06	B-22413 - 06 - 06	10	3/8	- 06	11/16 - 16	7.0	31.1	10.5			22
A-22413 - 06 - 08	B-22413 - 06 - 08	10	3/8	- 06	13/16 - 16	7.0	35.6	10.0			24
A-22411 - 08 - 06	B-22411 - 08 - 06	12	1/2	- 08	11/16 - 16	9.5	31.9	10.0			22
A-22413 - 08 - 08	B-22413 - 08 - 08	12	1/2	- 08	13/16 - 16	9.5	35.9	10.0			24
A-22413 - 08 - 10	B-22413 - 08 - 10	12	1/2	- 08	1 - 14	9.5	38.4	12.5			30
A-22413 - 08 - 12	B-22413 - 08 - 12	12	1/2	- 08	1.3/16 - 12	9.5	41.9	14.5			36
A-22411 - 10 - 08	B-22411 - 10 - 08	16	5/8	- 10	13/16 - 16	12.0	38.4	11.0			24
A-22413 - 10 - 10	B-22413 - 10 - 10	16	5/8	- 10	1 - 14	12.0	38.7	12.5			30
A-22413 - 10 - 12	B-22413 - 10 - 12	16	5/8	- 10	1.3/16 - 12	12.0	42.0	13.5			36
A-22411 - 12 - 10	B-22411 - 12 - 10	19	3/4	- 12	1 - 14	15.0	41.0	13.0			30
A-22413 - 12 - 12	B-22413 - 12 - 12	19	3/4	- 12	1.3/16 - 12	15.0	43.5	13.5			36
A-22413 - 12 - 16	B-22413 - 12 - 16	19	3/4	- 12	1.7/16 - 12	15.0	45.5	13.5			41
A-22411 - 16 - 12	B-22411 - 16 - 12	25	1	- 16	1.3/16 - 12	20.0	45.8	14.5			36
A-22413 - 16 - 16	B-22413 - 16 - 16	25	1	- 16	1.7/16 - 12	19.7	46.3	13.5			41
A-22413 - 16 - 20	B-22413 - 16 - 20	25	1	- 16	1.11/16 - 12	20.0	49.5	14.0			50
	B-22413 - 20 - 20	31	1.1/4	- 20	1.11/16 - 12	25.0	49.0	13.5			50
	B-22413 - 24 - 24	38	1.1/2	- 24	2 - 12	32.0	54.0	13.5			60

A-22441/43

B-22441/43

(SAE J516/ISO 12151-1)

45° MALE ORFS

CRIMP BACK/SLIP-ON NUT

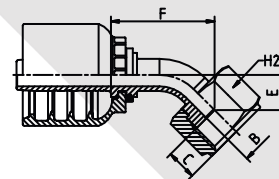

PART. REF. A	PART. REF. B	HOSE BORE			THREAD	DIMENSIONS					
		DN	INCH	SIZE	ORFS	B	F	C	E	H2	
A-22443 - 03 - 04		5	3/16	- 03	9/16 - 18	3.1	32.3	8.0	10.5		17
A-22443 - 04 - 04		6	1/4	- 04	9/16 - 18	4.1	31.0	10.5	10.5		17
A-22443 - 04 - 06		6	1/4	- 04	11/16 - 16	4.1	31.0	10.5	10.5		22
A-22443 - 05 - 06		8	5/16	- 05	11/16 - 16	5.5	31.9	10.5	10.5		22
A-22441 - 06 - 04	B-22441 - 06 - 04	10	3/8	- 06	9/16 - 18	*	*	*	*		*
A-22443 - 06 - 06	B-22443 - 06 - 06	10	3/8	- 06	11/16 - 16	7.0	32.5	10.5	11.0		22
A-22443 - 06 - 08	B-22443 - 06 - 08	10	3/8	- 06	13/16 - 16	7.0	34.0	10.0	12.5		24
A-22441 - 08 - 06	B-22441 - 08 - 06	12	1/2	- 08	11/16 - 16	9.5	40.0	9.0	11.0		22
A-22443 - 08 - 08	B-22443 - 08 - 08	12	1/2	- 08	13/16 - 16	9.5	42.0	10.0	13.0		24
A-22443 - 08 - 10	B-22443 - 08 - 10	12	1/2	- 08	1 - 14	9.5	42.0	12.5	13.5		30
A-22443 - 08 - 12	B-22443 - 08 - 12	12	1/2	- 08	1.3/16 - 12	9.5	50.0	13.5	18.5		36
A-22443 - 10 - 10	B-22443 - 10 - 10	16	5/8	- 10	1 - 14	12.0	49.0	12.5	16.0		30
A-22443 - 10 - 12	B-22443 - 10 - 12	16	5/8	- 10	1.3/16 - 12	12.0	51.5	13.5	18.5		36
A-22441 - 12 - 10	B-22441 - 12 - 10	19	3/4	- 12	1 - 14	15.0	57.5	13.5	16.5		30
A-22443 - 12 - 12	B-22443 - 12 - 12	19	3/4	- 12	1.3/16 - 12	15.0	60.5	13.5	21.5		36
A-22443 - 12 - 16	B-22443 - 12 - 16	19	3/4	- 12	1.7/16 - 12	15.0	64.5	13.5	21.0		41
A-22443 - 16 - 16	B-22443 - 16 - 16	25	1	- 16	1.7/16 - 12	19.7	72.0	13.5	23.5		41
A-22443 - 16 - 20	B-22443 - 16 - 20	25	1	- 16	1.11/16 - 12	20.0	74.0	13.5	25.5		50
	B-22443 - 20 - 20	31	1.1/4	- 20	1.11/16 - 12	25.0	82.0	13.5	27.0		50
	B-22443 - 24 - 24	38	1.1/2	- 24	2 - 12	32.0	98.0	13.5	31.5		60

A-22491/93

B-22491/93

(SAE J516/ISO 12151-1)

90° ORFS FEMALE

CRIMP BACK/SLIP-ON NUT

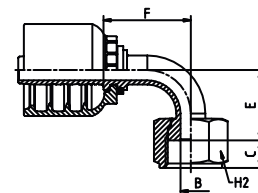

PART. REF. A	PART. REF. B	HOSE BORE			THREAD	DIMENSIONS					
		DN	INCH	SIZE	ORFS	B	F	C	E	H2	
A-22493 - 03 - 04		5	3/16	- 03	9/16 - 18	3.1	28.8	8.0	22.0		17
A-22493 - 04 - 04		6	1/4	- 04	9/16 - 18	4.1	27.5	8.0	22.0		17
A-22493 - 04 - 06		6	1/4	- 04	11/16 - 16	4.1	27.5	10.5	22.0		22
A-22493 - 05 - 06		8	5/16	- 05	11/16 - 16	5.5	28.6	10.5	23.0		22
A-22491 - 06 - 04	B-22491 - 06 - 04	10	3/8	- 06	9/16 - 18	7.0	30.0	8.0	23.0		17
A-22493 - 06 - 06	B-22493 - 06 - 06	10	3/8	- 06	11/16 - 16	7.0	30.0	10.5	24.0		22
A-22493 - 06 - 08	B-22493 - 06 - 08	10	3/8	- 06	13/16 - 16	7.0	30.0	10.0	26.5		24
A-22491 - 08 - 06	B-22491 - 08 - 06	12	1/2	- 08	11/16 - 16	9.5	35.0	10.0	24.5		22
A-22493 - 08 - 08	B-22493 - 08 - 08	12	1/2	- 08	13/16 - 16	9.5	40.5	10.0	30.0		24
A-22493 - 08 - 10	B-22493 - 08 - 10	12	1/2	- 08	1 - 14	9.5	40.5	12.5	30.0		30
A-22493 - 08 - 12	B-22493 - 08 - 12	12	1/2	- 08	1.3/16 - 12	9.5	48.0	13.5	37.5		36
A-22493 - 10 - 10	B-22493 - 10 - 10	16	5/8	- 10	1 - 14	12.0	48.0	12.5	37.5		30
A-22493 - 10 - 12	B-22493 - 10 - 12	16	5/8	- 10	1.3/16 - 12	12.0	48.0	13.5	41.0		36
A-22491 - 12 - 10	B-22491 - 12 - 10	19	3/4	- 12	1 - 14	15.0	54.0	13.5	38.0		30
A-22493 - 12 - 12	B-22493 - 12 - 12	19	3/4	- 12	1.3/16 - 12	15.0	56.5	13.5	48.0		36
A-22493 - 12 - 16	B-22493 - 12 - 16	19	3/4	- 12	1.7/16 - 12	15.0	62.5	13.5	47.5		41
A-22491 - 16 - 12	B-22491 - 16 - 12	25	1	- 16	1.3/16 - 12	20.0	62.5	13.5	48.0		36
A-22493 - 16 - 16	B-22493 - 16 - 16	25	1	- 16	1.7/16 - 12	19.7	71.5	13.5	56.0		41
A-22493 - 16 - 20	B-22493 - 16 - 20	25	1	- 16	1.11/16 - 12	20.0	71.5	13.5	58.5		50
	B-22493 - 20 - 20	31	1.1/4	- 20	1.11/16 - 12	25.0	83.0	13.5	66.0		50
	B-22493 - 24 - 24	38	1.1/2	- 24	2 - 12	32.0	102.0	13.5	79.5		60

A-24493

B-24493

(SAE J516/ISO 12151-1)

90° FEMALE ORFS LONG DROP

SLIP-ON NUT

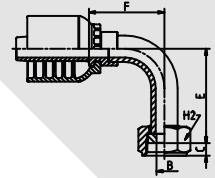

PART. REF. A	PART. REF. B	HOSE BORE			THREAD	DIMENSIONS					
		DN	INCH	SIZE	ORFS	B	F	C	E	H1	
A-24493 - 04 - 04		6	1/4	- 04	9/16 - 18	4.1	27.5	8.0	45.5		17
A-24493 - 04 - 06		6	1/4	- 04	11/16 - 16	7.0	24.5	9.5	53.5		22
A-24493 - 06 - 06	B-24493 - 06 - 06	10	3/8	- 06	11/16 - 16	7.0	31.5	9.5	53.5		22
A-24493 - 06 - 08	B-24493 - 06 - 08	10	3/8	- 06	13/16 - 16	7.0	35.7	10.0	53.5		24
A-24493 - 08 - 08	B-24493 - 08 - 08	12	1/2	- 08	13/16 - 16	9.5	40.5	10.0	63.5		24
A-24493 - 08 - 10	B-24493 - 08 - 10	12	1/2	- 08	1 - 14	9.5	44.5	12.5	64.0		30
A-24493 - 10 - 10	B-24493 - 10 - 10	16	5/8	- 10	1 - 14	12.0	48.0	12.5	69.0		30
A-24493 - 10 - 12	B-24493 - 10 - 12	16	5/8	- 10	1.3/16 - 12	12.0	54.5	13.5	73.0		36
A-24493 - 12 - 12	B-24493 - 12 - 12	19	3/4	- 12	1.3/16 - 20	15.0	56.5	13.5	96.0		36
A-24493 - 16 - 16	B-24493 - 16 - 16	25	1	- 16	1.7/16 - 12	19.7	71.5	13.5	113.5		41
	B-24493 - 20 - 20	31	1.1/4	- 20	1.11/16 - 12	25.0	92.0	13.5	129.0		50
	B-24493 - 24 - 24	38	1.1/2	- 24	2 - 12	32.0	102.0	13.5	141.0		60

A-23311

B-23311

(SAE J516/ISO 12151-3)

STRAIGHT SAE FLANGE 3000PSI

CODE 61

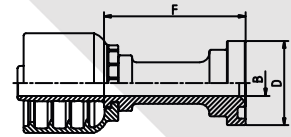

PART. REF. A	PART. REF. B	HOSE BORE			FLANGE	DIMENSIONS						
		DN	INCH	SIZE	CODE 61	B	F	D				
A-23311 - 08 - 08	B-23311 - 08 - 08	12	1/2	- 08	3/4 - 16	9.5	50.9	30.2				
A-23311 - 08 - 12	B-23311 - 08 - 12	12	1/2	- 08	1.1/16 - 12	9.5	57.7	38.1				
A-23311 - 10 - 12	B-23311 - 10 - 12	16	5/8	- 10	1.1/16 - 12	15.0	65.7	38.1				
A-23311 - 12 - 12	B-23311 - 12 - 12	19	3/4	- 12	1.1/16 - 12	15.0	58.0	38.1				
A-23311 - 12 - 16	B-23311 - 12 - 16	19	3/4	- 12	1.5/16 - 12	15.0	58.0	44.5				
A-23311 - 16 - 12	B-23311 - 16 - 12	25	1	- 16	1.1/16 - 12	15.0	60.5	38.1				
A-23311 - 16 - 16	B-23311 - 16 - 16	25	1	- 16	1.5/16 - 12	20.0	64.3	44.5				
A-23311 - 16 - 20	B-23311 - 16 - 20	25	1	- 16	1.5/8 - 12	20.0	64.5	50.8				
	B-23311 - 20 - 16	31	1.1/4	- 20	1.5/16 - 12	20.0	64.5	44.6				
	B-23311 - 20 - 20	31	1.1/4	- 20	1.5/8 - 12	25.0	64.3	50.8				
	B-23311 - 20 - 24	31	1.1/4	- 20	1.7/8 - 12	25.0	72.5	60.3				
	B-23311 - 24 - 24	38	1.1/2	- 24	1.7/8 - 12	32.0	75.6	60.3				
	B-23311 - 24 - 32	38	1.1/2	- 24	2.1/2 - 12	32.0	75.6	71.4				
	B-23311 - 32 - 32	51	2	- 32	2.1/2 - 12	42.0	78.9	71.4				
	B-23311 - 32 - 40	51	2	- 32	3 - 12	42.0	80.9	84.1				

A-23321

B-23321

(SAE J516/ISO 12151-3)

22.5° SAE FLANGE 3000PSI

CODE 61

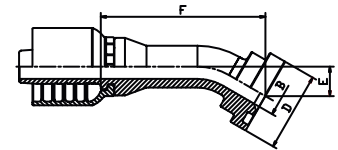

PART. REF. A	PART. REF. B	HOSE BORE			FLANGE	DIMENSIONS						
		DN	INCH	SIZE	CODE 61	B	F	D	E			
A-23321 - 08 - 08	B-23321 - 08 - 08	12	1/2	- 08	3/4 - 16	9.3	63.9	30.3	8.0			
A-23321 - 12 - 12	B-23321 - 12 - 12	19	3/4	- 12	1.1/16 - 12	15.0	74.7	38.1	9.8			
A-23321 - 12 - 16	B-23321 - 12 - 16	19	3/4	- 12	1.5/16 - 12	15.0	74.7	44.5	11.0			
A-23321 - 16 - 16	B-23321 - 16 - 16	25	1	- 16	1.5/16 - 12	20.0	88.8	44.5	11.5			
A-23321 - 16 - 20	B-23321 - 16 - 20	25	1	- 16	1.5/8 - 12	26.0	88.5	50.8	11.5			
	B-23321 - 20 - 20	31	1.1/4	- 20	1.5/8 - 12	26.0	100.0	50.8	12.0			
	B-23321 - 20 - 24	31	1.1/4	- 20	1.7/8 - 12	25.0	101.8	60.3	15.0			
	B-23321 - 24 - 32	38	1.1/2	- 24	2.1/2 - 12	32.0	116.5	60.3	14.0			
	B-23321 - 24 - 24	38	1.1/2	- 24	1.7/8 - 12	42.0	116.5	71.4	14.0			

A-23331

B-23331

(SAE J516/ISO 12151-3)
30° SAE FLANGE 3000PSI
CODE 61

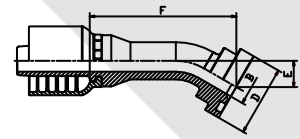

PART. REF. A	PART. REF. B	HOSE BORE			FLANGE	DIMENSIONS					
		DN	INCH	SIZE	CODE 61	B	F	D	E		
A-23331 - 08 - 08	B-23331 - 08 - 08	12	1/2	- 08	3/4 - 16	9.5	62.6	30.2	12.0		
A-23331 - 12 - 12	B-23331 - 12 - 12	19	3/4	- 12	1.1/16 - 12	15.0	73.2	38.1	13.9		
A-23331 - 12 - 16	B-23331 - 12 - 16	19	1/2	- 12	1.5/16 - 12	20.0	73.2	44.5	13.9		
A-23331 - 16 - 16	B-23331 - 16 - 16	25	1	- 16	1.5/16 - 12	20.0	86.8	44.5	18.0		
	B-23331 - 20 - 20	31	1.1/4	- 20	1.5/8 - 12	25.0	98.0	50.8	22.0		
	B-23331 - 24 - 24	38	1.1/2	- 24	1.7/8 - 12	32.0	114.3	60.3	20.0		

A-23341

B-23341

(SAE J516/ISO 12151-3)
45° SAE FLANGE 3000PSI
CODE 61

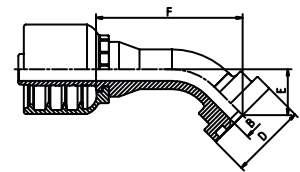

PART. REF. A	PART. REF. B	HOSE BORE			FLANGE	DIMENSIONS					
		DN	INCH	SIZE	FL61	B	F	D	C		
A-23341 - 08 - 08	B-23341 - 08 - 08	12	1/2	- 08	3/4 - 16	9.5	58.5	30.2	18.5		
A-23341 - 08 - 12	B-23341 - 08 - 12	12	1/2	- 08	1.1/16 - 12	9.5	59.5	38.1	19.0		
A-23341 - 10 - 12	B-23341 - 10 - 12	16	5/8	- 10	1.1/16 - 12	15.0	61.0	38.1	22.0		
A-23341 - 12 - 12	B-23341 - 12 - 12	19	3/4	- 12	1.1/16 - 12	15.0	68.5	38.1	23.0		
A-23341 - 12 - 16	B-23341 - 12 - 16	19	3/4	- 12	1.5/16 - 12	15.0	70.5	44.5	25.0		
A-23341 - 16 - 16	B-23341 - 16 - 16	25	1	- 16	1.5/16 - 12	20.0	81.5	44.5	27.5		
A-23341 - 16 - 20	B-23341 - 16 - 20	25	1	- 16	1.5/8 - 12	20.0	81.5	50.8	27.5		
	B-23341 - 20 - 20	31	1.1/4	- 20	1.5/8 - 12	25.0	94.5	50.8	32.0		
	B-23341 - 20 - 24	31	1.1/4	- 20	1.7/8 - 12	25.0	94.5	60.3	32.0		
	B-23341 - 24 - 24	38	1.1/2	- 24	1.7/8 - 12	32.0	107.5	60.3	34.5		
	B-23341 - 24 - 32	38	1.1/2	- 24	2.1/2 - 12	32.0	107.5	71.4	40.0		
	B-23341 - 32 - 32	51	2	- 32	2.1/2 - 12	42.0	140.0	71.4	55.0		

A-23361

B-23361

(SAE J516/ISO 12151-3)
60° SAE FLANGE 3000PSI
CODE 61

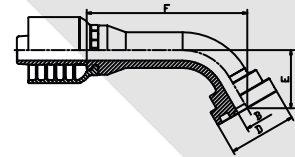

PART. REF. A	PART. REF. B	HOSE BORE			FLANGE	DIMENSIONS					
		DN	INCH	SIZE	CODE 61	B	F	D	E		
A-23361 - 08 - 08	B-23361 - 08 - 08	12	1/2	- 08	1/2	9.3	71.5	30.2	25.8		
A-23361 - 12 - 12	B-23361 - 12 - 12	19	3/4	- 12	3/4	15.0	86.9	38.1	33.0		
A-23361 - 16 - 16	B-23361 - 16 - 16	25	1	- 16	1	19.8	104.0	44.5	39.0		
A-23361 - 16 - 20	B-23361 - 16 - 20	25	1	- 16	1.1/4	26.0	104.0	44.5	39.0		
	B-23361 - 20 - 20	31	1.1/4	- 20	1.1/4	25.0	120.0	50.8	50.0		
	B-23361 - 20 - 24	31	1.1/4	- 20	1.1/4	32.0	121.0	60.3	44.7		
	B-23361 - 24 - 24	38	1.1/2	- 24	1.1/2	32.0	143.6	60.3	50.7		

A-23371

B-23371

(SAE J516/ISO 12151-3)
67.5° SAE FLANGE 3000PSI
CODE 61

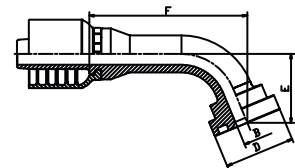

PART. REF. A	PART. REF. B	HOSE BORE			FLANGE	DIMENSIONS					
		DN	INCH	SIZE	CODE 61	B	F	D	E		
A-23371 - 08 - 08	B-23371 - 08 - 08	12	1/2	- 08	1/2	9.3	67.9	30.2	29.3		
A-23371 - 12 - 12	B-23371 - 12 - 12	19	3/4	- 12	3/4	15.0	82.2	38.1	38.0		
A-23371 - 12 - 16	B-23371 - 12 - 16	19	3/4	- 12	1	20.0	82.2	44.5	38.0		
A-23371 - 16 - 16	B-23371 - 16 - 16	25	1	- 16	1	19.8	98.6	44.5	45.0		
A-23371 - 16 - 20	B-23371 - 16 - 20	25	1	- 16	1.1/4	26.0	98.5	50.8	45.0		
	B-23371 - 20 - 20	31	1.1/4	- 20	1.1/4	26.0	114.0	50.8	50.0		
	B-23371 - 24 - 24	38	1.1/2	- 24	1.1/2	32.0	136.4	60.3	59.2		

A-23391

B-23391

(SAE J516/ISO 12151-3)
90° SAE FLANGE 3000PSI
CODE 61

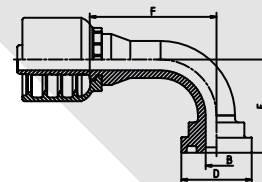

PART. REF. A	PART. REF. B	HOSE BORE			FLANGE	DIMENSIONS					
		DN	INCH	SIZE	CODE 61	B	F	D	E		
A-23391 - 08 - 08	B-23391 - 08 - 08	12	1/2	- 08	1/2	9.5	54.5	30.2	41.0		
A-23391 - 08 - 12	B-23391 - 08 - 12	12	1/2	- 08	3/4	9.5	54.5	38.1	41.0		
A-23391 - 10 - 12	B-23391 - 10 - 12	16	5/8	- 10	3/4	12.0	56.0	38.1	47.5		
A-23391 - 12 - 12	B-23391 - 12 - 12	19	3/4	- 12	3/4	15.0	64.5	38.1	52.0		
A-23391 -12-12120	B-23391 -12-12120	19	3/4	- 12	3/4	15.0	64.5	38.1	120.0		
A-23391 -12-12160	B-23391 -12-12160	19	3/4	- 12	1	20.0	64.5	38.1	160.0		
A-23391 - 12 - 16	B-23391 - 12 - 16	19	3/4	- 12	1	15.0	64.5	44.5	52.0		
A-23391 - 16 - 16	B-23391 - 16 - 16	25	1	- 16	1	20.0	77.5	44.5	62.0		
A-23391 -16-16120	B-23391 -16-16120	25	1	- 16	1	20.0	77.5	44.5	120.0		
A-23391 - 16 - 20	B-23391 - 16 - 20	25	1	- 16	1.1/4	20.0	77.5	50.8	65.0		
A-23391 -16-20120	B-23391 -16-20120	25	1	- 16	1.1/4	26.0	77.5	50.8	120.0		
	B-23391 - 20 - 20	31	1.1/4	- 20	1.1/4	25.0	90.5	50.8	75.0		
	B-23391 - 20 - 24	31	1.1/4	- 20	1.1/2	25.0	90.5	60.3	80.0		
	B-23391 - 24 - 20	38	1.1/2	- 24	1.1/4	32.0	104.5	50.8	75.0		
	B-23391 - 24 - 24	38	1.1/2	- 24	1.1/2	32.0	107.5	60.3	90.0		
	B-23391 -24-24120	38	1.1/2	- 24	1.1/2	32.0	90.5	60.3	120.0		
	B-23391 - 24 - 32	38	1.1/2	- 24	2	32.0	108.0	71.4	95.0		
	B-23391 - 32 - 32	51	2	- 32	2	42.0	135.0	71.4	130.0		

A-23611

B-23611

(SAE J516/ISO 12151-3)
STRAIGHT SAE FLANGE 6000PSI
CODE 62

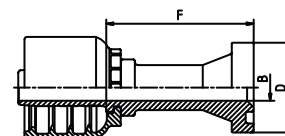

PART. REF. A	PART. REF. B	HOSE BORE			FLANGE	DIMENSIONS				
		DN	INCH	SIZE	CODE 62	B	F	D		
A-23611 - 08 - 08	B-23611 - 08 - 08	12	1/2	- 08	1/2	9.5	52.1	31.8		
A-23611 - 08 - 12	B-23611 - 08 - 12	12	1/2	- 08	3/4	9.5	68.4	41.3		
A-23611 - 10 - 08	B-23611 - 10 - 08	16	5/8	- 10	1/2	9.3	52.0	31.8		
A-23611 - 10 - 12	B-23611 - 10 - 12	16	5/8	- 10	3/4	12.0	70.2	41.3		
A-23611 - 12 - 12	B-23611 - 12 - 12	19	3/4	- 12	3/4	15.0	69.0	41.3		
A-23611 - 12 - 16	B-23611 - 12 - 16	19	3/4	- 12	1	15.0	81.0	47.6		
A-23611 - 16 - 12	B-23611 - 16 - 12	25	1	- 16	3/4	20.0	81.0	41.3		
A-23611 - 16 - 16	B-23611 - 16 - 16	25	1	- 16	1	20.0	82.3	47.6		
A-23611 - 16 - 20	B-23611 - 16 - 20	25	1	- 16	1.1/4	20.0	89.8	54.0		
	B-23611 - 20 - 20	31	1.1/4	- 20	1.1/4	25.0	84.5	54.0		
	B-23611 - 20 - 24	31	1.1/4	- 20	1.1/2	25.0	90.5	63.5		
	B-23611 - 24 - 24	38	1.1/2	- 24	1.1/2	32.0	92.6	63.5		
	B-23611 - 32 - 32	51	2	- 32	2	42.0	78.9	79.4		

A-23641

B-23641

(SAE J516/ISO 12151-3)
45° SAE FLANGE 6000PSI
CODE 62

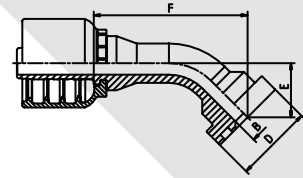

PART. REF. A	PART. REF. B	HOSE BORE			FLANGE	DIMENSIONS					
		DN	INCH	SIZE	CODE 62	B	F	D	E		
A-23641 - 08 - 08	B-23641 - 08 - 08	12	1/2	- 08	1/2	9.5	62.0	31.8	22.0		
A-23641 - 08 - 12	B-23641 - 08 - 12	12	1/2	- 08	3/4	9.5	59.5	41.3	25.0		
A-23641 - 10 - 12	B-23641 - 10 - 12	16	5/8	- 10	3/4	12.0	65.0	41.3	26.0		
A-23641 - 12 - 12	B-23641 - 12 - 12	19	3/4	- 12	3/4	15.0	73.0	41.3	28.0		
A-23641 - 12 - 16	B-23641 - 12 - 16	19	3/4	- 12	1	15.0	77.0	47.6	32.5		
A-23641 - 16 - 12	B-23641 - 16 - 12	25	1	- 16	3/4	15.0	80.0	41.3	30.0		
A-23641 - 16 - 16	B-23641 - 16 - 16	25	1	- 16	1	20.0	83.5	47.6	32.5		
A-23641 - 16 - 20	B-23641 - 16 - 20	25	1	- 16	1.1/4	20.0	88.5	54.0	37.5		
	B-23641 - 20 - 20	31	1.1/4	- 20	1.1/4	25.0	100.0	54.0	37.5		
	B-23641 - 20 - 24	31	1.1/4	- 20	1.1/2	32.0	102.5	63.5	45.0		
	B-23641 - 24 - 24	38	1.1/2	- 24	1.1/2	32.0	118.0	63.5	44.0		
	B-23641 - 32 - 32	51	2	- 32	2	42.0	151.7	79.4	56.0		

A-23691

B-23691

(SAE J516/ISO 12151-3)
90° SAE FLANGE 6000PSI
CODE 62

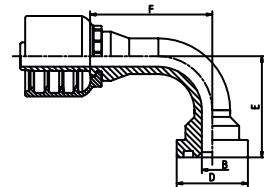

PART. REF. A	PART. REF. B	HOSE BORE			FLANGE	DIMENSIONS					
		DN	INCH	SIZE	CODE 62	B	F	D	E		
A-23691 - 08 - 08	B-23691 - 08 - 08	12	1/2	- 08	1/2	9.3	54.5	31.8	45.0		
A-23691 - 08 - 12	B-23691 - 08 - 12	12	1/2	- 08	3/4	15.0	54.5	41.3	53.0		
A-23691 - 10 - 12	B-23691 - 10 - 12	16	5/8	- 10	3/4	12.0	56.0	41.3	58.0		
A-23691 - 12 - 12	B-23691 - 12 - 12	19	3/4	- 12	3/4	15.0	64.0	41.3	59.0		
A-23691 - 12 - 16	B-23691 - 12 - 16	19	3/4	- 12	1	15.0	64.5	47.6	65.0		
A-23691 - 16 - 12	B-23691 - 16 - 12	25	1	- 16	3/4	20.0	74.2	41.3	68.0		
A-23691 - 16 - 16	B-23691 - 16 - 16	25	1	- 16	1	20.0	73.5	47.6	65.0		
A-23691 - 16 - 20	B-23691 - 16 - 20	25	1	- 16	1.1/4	20.0	73.5	54.0	75.0		
	B-23691 - 20 - 20	31	1.1/4	- 20	1.1/4	25.0	85.5	54.0	81.0		
	B-23691 - 20 - 24	31	1.1/4	- 20	1.1/2	25.0	91.5	63.5	85.5		
	B-23691 - 24 - 24	38	1.1/2	- 24	1.1/2	32.0	106.0	63.5	94.5		
	B-23691 - 32 - 32	51	2	- 24	2	42.0	138.0	79.4	132.0		

A-23911

B-23911

STRAIGHT "SUPERCAT" STYLE FLANGE
CODE SUPERCAT

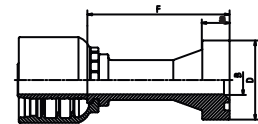

PART. REF. A	PART. REF. B	HOSE BORE			FLANGE	DIMENSIONS					
		DN	INCH	SIZE	CODE CAT.	B	F	D	S		
A-23911 - 12 - 12	B-23911 - 12 - 12	19	3/4	- 12	3/4	15.0	74.5	41.3	14.3		
A-23911 - 16 - 16	B-23911 - 16 - 16	25	1	- 16	1	20.0	86.8	47.6	14.3		
A-23911 - 16 - 20	B-23911 - 16 - 20	25	1	- 16	1.1/4	20.0	92.3	54.0	14.3		
	B-23911 - 20 - 20	31	1.1/4	- 20	1.1/4	25.0	86.0	54.0	14.3		
	B-23911 - 24 - 24	38	1.1/2	- 24	1.1/2	32.0	94.0	63.5	14.3		

A-23941

B-23941

45° "SUPERCAT" STYLE FLANGE
CODE SUPERCAT

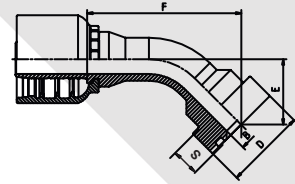

PART. REF. A	PART. REF. B	HOSE BORE			FLANGE	DIMENSIONS				
		DN	INCH	SIZE	CODE CAT.	B	F	D	E	S
A-23941 - 12 - 12	B-23941 - 12 - 12	19	3/4	- 12	3/4	15.0	89.0	41.3	32.0	14.3
A-23941 - 16 - 16	B-23941 - 16 - 16	25	1	- 16	1	20.0	89.5	47.6	36.5	14.3
A-23941 - 16 - 20	B-23941 - 16 - 20	25	1	- 16	1.1/4	20.0	92.5	54.0	40.5	14.3
	B-23941 - 20 - 20	31	1.1/4	- 20	1.1/4	25.0	102.0	54.0	41.5	14.3

A-23991

B-23991

90° "SUPERCAT" STYLE FLANGE
CODE SUPERCAT

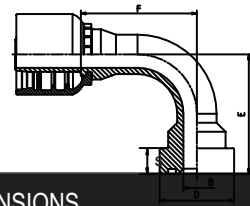

PART. REF. A	PART. REF. B	HOSE BORE			FLANGE	DIMENSIONS				
		DN	INCH	SIZE	CODE CAT.	B	F	D	E	S
A-23991 - 12 - 12	B-23991 - 12 - 12	19	3/4	- 12	3/4	15.0	64.5	41.3	64.6	14.3
A-23991 - 16 - 16	B-23991 - 16 - 16	25	1	- 16	1	20.0	77.5	47.6	76.5	14.3
A-23991 - 16 - 20	B-23991 - 16 - 20	25	1	- 16	1.1/4	20.0	75.5	54.0	80.5	14.3
	B-23991 - 20 - 20	31	1.1/4	- 20	1.1/4	25.0	85.5	54.0	87.0	14.3

A-24111

B-24111

STRAIGHT "KOMATSU" STYLE FLANGE
CODE KOMATSU

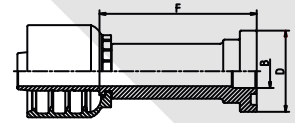

PART. REF. A	PART. REF. B	HOSE BORE			FLANGE	DIMENSIONS						
		DN	INCH	SIZE	KOMATSU	B	F	D				
A-24111 - 10 - 10	B-24111 - 10 - 10	16	5/8	- 10	5/8	12.0	65.7	34.2				

A-24141

B-24141

45° "KOMATSU" STYLE FLANGE
CODE KOMATSU

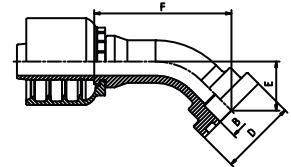

PART. REF. A	PART. REF. B	HOSE BORE			FLANGE	DIMENSIONS						
		DN	INCH	SIZE	KOMATSU	B	F	D	E			
A-24141 - 10 - 10	B-24141 - 10 - 10	16	5/8	- 10	5/8	12.0	61.0	34.2	22.0			

A-24191

B-24191

90° "KOMATSU" STYLE FLANGE
CODE KOMATSU

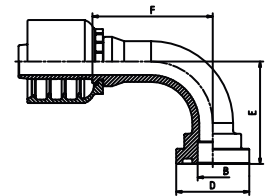

PART. REF. A	PART. REF. B	HOSE BORE			FLANGE	DIMENSIONS						
		DN	INCH	SIZE	KOMATSU	B	F	D	E			
A-24191 - 10 - 10	B-24191 - 10 - 10	16	5/8	- 10	5/8	14.0	56.0	34.0	47.5			

A-10510

B-10510

(BS5200/ISO 8434-6)

BSP MALE PARALLEL 60° CONE SEAT

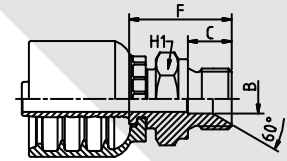

PART. REF. A	PART. REF. B	HOSE BORE			THREAD	DIMENSIONS				
		DN	INCH	SIZE	BSP	B	F	C		H1
A-10510 - 03 - 02		5	3/16	- 03	1/8 - 28	3.1	22.5	10.0		14
A-10510 - 04 - 02		5	1/4	- 04	1/8 - 28	4.1	22.5	10.0		14
A-10510 - 04 - 04		6	1/4	- 04	1/4 - 19	4.1	25.5	11.0		19
A-10510 - 04 - 06		6	1/4	- 04	3/8 - 19	4.1	27.0	12.0		22
A-10510 - 05 - 06		8	5/16	- 05	3/8 - 19	8.0	27.5	12.0		22
A-10510 - 06 - 04	B-10510 - 06 - 04	10	3/8	- 06	1/4 - 19	7.0	26.0	11.0		19
A-10510 - 06 - 06	B-10510 - 06 - 06	10	3/8	- 06	3/8 - 19	7.0	28.1	13.5		22
A-10510 - 06 - 08	B-10510 - 06 - 08	10	3/8	- 06	1/2 - 14	7.0	30.6	14.0		27
A-10510 - 08 - 06	B-10510 - 08 - 06	12	1/2	- 08	3/8 - 19	9.5	28.1	12.0		22
A-10510 - 08 - 08	B-10510 - 08 - 08	12	1/2	- 08	1/2 - 14	9.5	31.1	14.0		27
A-10510 - 08 - 10	B-10510 - 08 - 10	12	1/2	- 08	5/8 - 14	9.5	33.1	16.0		30
A-10510 - 08 - 12	B-10510 - 08 - 12	12	1/2	- 08	3/4 - 14	9.5	34.1	16.0		32
A-10510 - 10 - 10	B-10510 - 10 - 10	16	5/8	- 10	5/8 - 14	12.0	33.1	16.0		30
A-10510 - 10 - 12	B-10510 - 10 - 12	16	5/8	- 10	3/4 - 14	12.0	34.1	16.0		32
A-10510 - 12 - 12	B-10510 - 12 - 12	19	3/4	- 12	3/4 - 14	15.0	35.5	16.0		32
A-10510 - 12 - 16	B-10510 - 12 - 16	19	3/4	- 12	1 - 11	15.0	39.5	19.0		41
A-10510 - 16 - 16	B-10510 - 16 - 16	25	1	- 16	1 - 11	20.0	40.8	19.0		41
A-10510 - 16 - 20	B-10510 - 16 - 20	25	1	- 16	1.1/4 - 11	20.0	44.8	20.0		50
	B-10510 - 20 - 20	31	1.1/4	- 20	1.1/4 - 11	25.0	46.5	20.0		50
	B-10510 - 24 - 24	38	1.1/2	- 24	1.1/2 - 11	32.0	51.0	22.0		55
	B-10510 - 32 - 32	51	2	- 32	2 - 11	42.0	58.0	25.0		70

A-10610

B-10610

BSP MALE FLAT SEAT

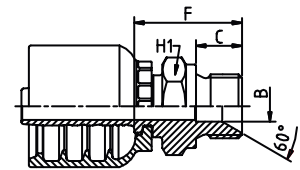

PART. REF. A	PART. REF. B	HOSE BORE			THREAD	DIMENSIONS				
		DN	INCH	SIZE	BSP	B	F	C		H1
A-10610 - 04 - 04		6	1/4	- 04	1/4 - 19	4.1	25.5	11.0		19
A-10610 - 06 - 06	B-10610 - 06 - 06	10	3/8	- 06	3/8 - 19	9.5	28.1	12.0		22
A-10610 - 06 - 08	B-10610 - 06 - 08	10	3/8	- 06	1/2 - 14	13.0	30.6	14.0		27
A-10610 - 08 - 08	B-10610 - 08 - 08	12	1/2	- 08	1/2 - 14	13.0	31.1	14.0		27
A-10610 - 12 - 12	B-10610 - 12 - 12	19	3/4	- 12	3/4 - 14	18.0	35.5	16.0		32
A-10610 - 16 - 16	B-10610 - 16 - 16	25	1	- 16	1 - 11	20.0	40.8	19.0		41

A-10710
B-10710
 (ISO 7)
 BSP MALE TAPERED

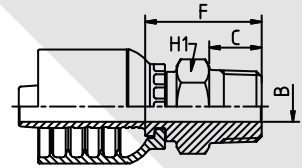

PART. REF. A	PART. REF. B	HOSE BORE			THREAD	DIMENSIONS						
		DN	INCH	SIZE	BSP	B	F	C			H1	
A-10710 - 04 - 02		6	1/4	- 04	1/8 - 28	4.1	20.6	10.5				12
A-10710 - 04 - 04		6	1/4	- 04	1/4 - 19	4.1	25.0	12.5				14
A-10710 - 06 - 06	B-10710 - 06 - 06	10	3/8	- 06	3/8 - 19	7.0	27.1	15.0				19
A-10710 - 06 - 08	B-10710 - 06 - 08	10	3/8	- 06	1/2 - 14	10.0	30.6	15.0				22
A-10710 - 08 - 08	B-10710 - 08 - 08	12	1/2	- 08	1/2 - 14	10.0	31.1	15.0				22
A-10710 - 10 - 12	B-10710 - 10 - 12	16	5/8	- 10	3/4 - 14	17.0	37.0	17.0				27
A-10710 - 12 - 12	B-10710 - 12 - 12	19	3/4	- 12	3/4 - 14	17.0	35.5	17.0				27
A-10710 - 16 - 16	B-10710 - 16 - 16	25	1	- 16	1 - 11	22.5	41.8	21.0				36
	B-10710 - 20 - 20	31	1.1/4	- 20	1.1/4 - 11	28.5	47.5	23.0				46

A-20612/13
B-20612/13
 [THRUST WIRE/SLIP-ON NUT]
 BSP FEMALE FLAT SEAT

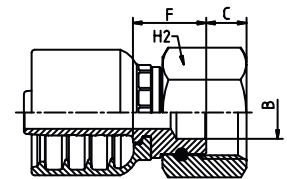

PART. REF. A	PART. REF. B	HOSE BORE			THREAD	DIMENSIONS						
		DN	INCH	SIZE	BSP	B	F	C			H2	
A-20613 - 04 - 04		6	1/4	- 04	1/4 - 19	4.1	17.0	8.0				19
A-20613 - 06 - 06	B-20613 - 06 - 06	10	3/8	- 06	3/8 - 19	7.0	18.0	9.0				22
A-20613 - 06 - 08	B-20613 - 06 - 08	10	3/8	- 06	1/2 - 14	7.0	19.5	11.0				27
A-20613 - 08 - 08	B-20613 - 08 - 08	12	1/2	- 08	1/2 - 14	9.3	17.9	9.8				27
A-20612 - 08 - 12	B-20612 - 08 - 12	12	1/2	- 08	3/4 - 14	15.0	20.9	11.5				32
A-20612 - 10 - 10	B-20612 - 10 - 10	16	5/8	- 10	5/8 - 14	*	*	*				*
A-20612 - 10 - 12	B-20612 - 10 - 12	16	5/8	- 10	3/4 - 14	15.0	20.7	11.5				32
A-20612 - 12 - 12	B-20612 - 12 - 12	19	3/4	- 12	3/4 - 14	15.0	22.8	11.5				32
A-20612 - 12 - 16	B-20612 - 12 - 16	19	3/4	- 12	1 - 11	15.0	23.5	13.0				38
A-20612 - 16 - 16	B-20612 - 16 - 16	25	1	- 16	1 - 11	20.0	24.8	13.0				38

A-20812

B-20812

(BS5200/ISO 12151-6)

BSP O'RING FEMALE 60° CONE SEAT
[THRUST WIRE]

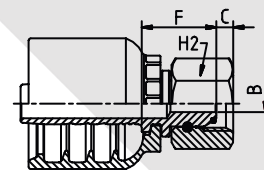

PART. REF. A	PART. REF. B	HOSE BORE			THREAD	DIMENSIONS						
		DN	INCH	SIZE	BSP	B	F	C			H2	
A-20812 - 03 - 02		5	3/16	- 03	1/2 - 28	3.1	15.8	4.5				14
A-20812 - 03 - 04		5	3/16	- 03	1/4 - 19	3.1	16.5	5.0				19
A-20812 - 04 - 02		6	1/4	- 04	1/2 - 28	4.1	16.5	4.5				14
A-20812 - 04 - 04		6	1/4	- 04	1/4 - 19	4.1	18.5	5.0				19
A-20812 - 04 - 06		6	1/4	- 04	3/8 - 19	4.1	18.1	5.5				22
A-20812 - 05 - 04		8	5/16	- 05	1/4 - 19	5.5	17.5	5.0				19
A-20812 - 05 - 06		8	5/16	- 05	3/8 - 19	5.5	19.1	5.5				22
A-20812 - 06 - 04	B-20812 - 06 - 04	10	3/8	- 06	1/4 - 19	7.0	18.5	5.0				19
A-20812 - 06 - 06	B-20812 - 06 - 06	10	3/8	- 06	3/8 - 19	7.0	20.4	5.5				22
A-20812 - 06 - 08	B-20812 - 06 - 08	10	3/8	- 06	1/2 - 14	7.0	23.8	6.5				27
A-20812 - 08 - 06	B-20812 - 08 - 06	12	1/2	- 08	3/8 - 19	9.5	21.0	5.5				22
A-20812 - 08 - 08	B-20812 - 08 - 08	12	1/2	- 08	1/2 - 14	9.5	22.2	6.5				27
A-20812 - 08 - 10	B-20812 - 08 - 10	12	1/2	- 08	5/8 - 14	9.5	21.9	9.5				30
A-20812 - 08 - 12	B-20812 - 08 - 12	12	1/2	- 08	3/4 - 14	9.5	23.4	9.0				32
A-20812 - 10 - 10	B-20812 - 10 - 10	16	5/8	- 10	5/8 - 14	12.0	22.1	9.5				30
A-20812 - 10 - 12	B-20812 - 10 - 12	16	5/8	- 10	3/4 - 14	12.0	23.2	9.0				32
A-20812 - 12 - 12	B-20812 - 12 - 12	19	3/4	- 12	3/4 - 14	15.0	25.0	9.0				32
A-20812 - 12 - 16	B-20812 - 12 - 16	19	3/4	- 12	1 - 11	15.0	26.0	10.0				38
A-20812 - 16 - 12	B-20812 - 16 - 12	25	1	- 16	3/4 - 14	19.0	26.5	9.0				32
A-20812 - 16 - 16	B-20812 - 16 - 16	25	1	- 16	1 - 11	20.0	27.8	10.0				38
A-20812 - 16 - 20	B-20812 - 16 - 20	25	1	- 16	1.1/4 - 11	19.7	30.8	10.5				50
	B-20812 - 20 - 16	31	1.1/4	- 20	1 - 11	25.0	29.0	10.0				38
	B-20812 - 20 - 20	31	1.1/4	- 20	1.1/4 - 11	25.0	31.5	10.5				50
	B-20812 - 20 - 24	31	1.1/4	- 20	1.1/2 - 11	25.0	29.5	12.5				55
	B-20812 - 24 - 20	38	1.1/2	- 24	1.1/4 - 11	32.0	31.5	10.5				50
	B-20812 - 24 - 24	38	1.1/2	- 24	1.1/2 - 11	32.0	30.5	12.5				55
	B-20812 - 24 - 32	38	1.1/2	- 24	2 - 11	32.0	30.0	16.0				70
	B-20812 - 32 - 32	51	2	- 32	2 - 11	42.0	34.5	16.0				70

A-20842

B-20842

(BS5200/ISO 12151-6)

45° BSP O'RING FEMALE 60° CONE SEAT
[THRUST WIRE]

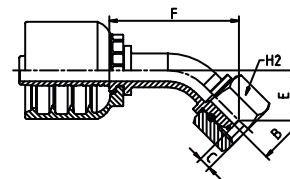

PART. REF. A	PART. REF. B	HOSE BORE			THREAD	DIMENSIONS						
		DN	INCH	SIZE	BSP	B	F	C	E	H2		
A-20842 - 04 - 02		6	1/4	- 02	1/8 - 28	4.1	36.0	4.5	15.0			14
A-20842 - 04 - 04		6	1/4	- 04	1/4 - 19	4.1	36.3	5.0	15.0			19
A-20842 - 04 - 06		6	1/4	- 04	3/8 - 19	4.1	37.5	5.5	16.0			22
A-20842 - 06 - 04	B-20842 - 06 - 04	10	3/8	- 06	1/4 - 19	*	*	*	*			*
A-20842 - 06 - 06	B-20842 - 06 - 06	10	3/8	- 06	3/8 - 19	7.0	44.5	5.5	18.5			22
A-20842 - 06 - 08	B-20842 - 06 - 08	10	3/8	- 06	1/2 - 14	7.0	42.5	6.5	16.0			27
A-20842 - 08 - 08	B-20842 - 08 - 08	12	1/2	- 08	1/2 - 14	9.5	52.0	6.5	20.5			27
A-20842 - 08 - 10	B-20842 - 08 - 10	12	1/2	- 08	5/8 - 14	12.1	54.5	10.2	22.5			28
A-20842 - 08 - 12	B-20842 - 08 - 12	12	1/2	- 08	3/4 - 14	15.0	57.0	9.0	25.0			32
A-20842 - 10 - 10	B-20842 - 10 - 10	16	5/8	- 10	5/8 - 14	12.0	63.5	9.5	27.5			30
A-20842 - 10 - 12	B-20842 - 10 - 12	16	5/8	- 10	3/4 - 14	15.0	64.0	9.0	27.0			32
A-20842 - 12 - 12	B-20842 - 12 - 12	19	3/4	- 12	3/4 - 14	15.0	71.0	9.0	29.0			32
A-20842 - 12 - 16	B-20842 - 12 - 16	19	3/4	- 12	1 - 11	19.8	72.5	10.5	30.0			38
A-20842 - 16 - 12	B-20842 - 16 - 12	25	1	- 16	3/4 - 14	19.7	79.5	9.0	29.0			32
A-20842 - 16 - 16	B-20842 - 16 - 16	25	1	- 16	1 - 11	20.0	90.5	10.0	35.6			38
A-20842 - 16 - 20	B-20842 - 16 - 20	25	1	- 16	1.1/4 - 11	19.7	93.0	10.5	38.0			50
	B-20842 - 20 - 20	31	1.1/4	- 20	1.1/4 - 11	25.0	101.5	10.5	39.0			50
	B-20842 - 20 - 24	31	1.1/4	- 20	1.1/2 - 11	25.0	118.5	12.5	40.5			55
	B-20842 - 24 - 20	38	1.1/2	- 24	1.1/4 - 11	32.0	106.5	10.5	42.0			50
	B-20842 - 24 - 24	38	1.1/2	- 24	1.1/2 - 11	32.0	118.0	12.5	45.0			55
	B-20842 - 32 - 32	51	2	- 32	2 - 11	42.0	144.0	16.0	58.0			70

A-20882

B-20882

(BS5200/ISO 12151-6)

90° BSP O’RING FEMALE COMPACT ELBOW 60° CONE SEAT
[THRUST WIRE]

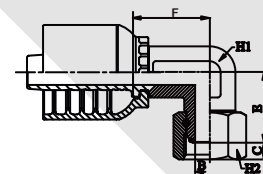

PART. REF. A	PART. REF. B	HOSE BORE			THREAD	DIMENSIONS					
		DN	INCH	SIZE	BSP	B	F	C	E	H1	H2
A-20882 - 04 - 04		6	1/4	- 04	1/4 - 19	4.1	18.5	5.0	22.0	14	19
A-20882 - 06 - 06	B-20882 - 06 - 06	10	3/8	- 06	3/8 - 19	7.0	23.1	5.5	27.5	19	22
A-20882 - 08 - 08	B-20882 - 08 - 08	12	1/2	- 08	1/2 - 14	9.5	23.0	6.5	31.1	22	27
A-20882 - 10 - 10	B-20882 - 10 - 10	16	5/8	- 10	5/8 - 14	12.0	24.6	9.5	32.5	24	30
A-20882 - 12 - 12	B-20882 - 12 - 12	19	3/4	- 12	3/4 - 14	15.0	28.0	9.0	36.0	27	32
A-20882 - 16 - 16	B-20882 - 16 - 16	25	1	- 16	1 - 11	20.0	30.0	10.0	43.0	36	38

A-20892

B-20892

(BS5200/ISO 12151-6)

90° BSP O’RING FEMALE 60° CONE SEAT
[THRUST WIRE]

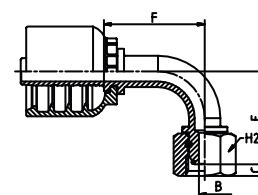

PART. REF. A	PART. REF. B	HOSE BORE			THREAD	DIMENSIONS					
		DN	INCH	SIZE	BSP	B	F	C	E	H2	
A-20892 - 03 - 02		5	3/16	- 03	1/8 - 28	3.1	28.5	4.5	28.5		14
A-20892 - 04 - 02		6	1/4	- 04	1/8 - 28	4.1	28.5	4.5	28.5		14
A-20892 - 04 - 04		6	1/4	- 04	1/4 - 19	4.1	28.5	5.0	28.5		19
A-20892 - 04 - 06		6	1/4	- 04	3/8 - 19	4.1	28.5	5.5	30.0		22
A-20892 - 05 - 06		8	5/16	- 05	3/8 - 19	7.0	32.0	6.0	27.5		22
A-20892 - 05 - 08		8	5/16	- 05	1/2 - 14	9.3	36.5	6.5	32.0		27
A-20892 - 06 - 04	B-20892 - 06 - 04	10	3/8	- 06	1/4 - 19	7.0	35.5	5.0	33.0		19
A-20892 - 06 - 06	B-20892 - 06 - 06	10	3/8	- 06	3/8 - 19	7.0	35.5	5.5	36.0		22
A-20892 - 06 - 08	B-20892 - 06 - 08	10	3/8	- 06	1/2 - 14	7.0	36.5	6.5	32.0		27
A-20892 - 08 - 06	B-20892 - 08 - 06	12	1/2	- 08	3/8 - 19	7.0	45.0	6.0	41.0		22
A-20892 - 08 - 08	B-20892 - 08 - 08	12	1/2	- 08	1/2 - 14	9.5	44.5	6.5	42.0		27
A-20892 - 08 - 10	B-20892 - 08 - 10	12	1/2	- 08	5/8 - 14	12.1	44.0	10.2	44.0		28
A-20892 - 08 - 12	B-20892 - 08 - 12	12	1/2	- 08	3/4 - 14	9.5	44.0	9.0	45.5		32
A-20892 - 10 - 10	B-20892 - 10 - 10	16	5/8	- 10	5/8 - 14	12.0	53.0	9.5	55.0		30
A-20892 - 10 - 12	B-20892 - 10 - 12	16	5/8	- 10	3/4 - 14	15.0	53.5	9.0	55.0		32
A-20892 - 12 - 12	B-20892 - 12 - 12	19	3/4	- 12	3/4 - 14	19.7	61.5	9.0	60.0		32
A-20892 - 12 - 16	B-20892 - 12 - 16	19	3/4	- 12	1 - 11	15.0	61.5	10.0	62.0		38
A-20892 - 16 - 12	B-20892 - 16 - 12	25	1	- 16	3/4 - 14	19.7	79.5	9.0	60.0		32
A-20892 - 16 - 16	B-20892 - 16 - 16	25	1	- 16	1 - 11	20.0	79.5	10.0	76.0		38
A-20892 - 16 - 20	B-20892 - 16 - 20	25	1	- 16	1.1/4 - 11	19.7	79.5	10.5	78.5		50
	B-20892 - 20 - 16	31	1.1/4	- 20	1 - 11	25.0	85.0	10.0	76.0		38
	B-20892 - 20 - 20	31	1.1/4	- 20	1.1/4 - 11	25.0	90.5	10.5	83.5		50
	B-20892 - 20 - 24	31	1.1/4	- 20	1.1/2 - 11	25.0	90.5	12.5	84.5		55
	B-20892 - 24 - 20	38	1.1/2	- 24	1.1/4 - 11	32.0	95.0	10.5	90.5		50
	B-20892 - 24 - 24	38	1.1/2	- 24	1.1/2 - 11	32.0	108.0	12.5	98.5		55
	B-20892 - 32 - 32	51	2	- 32	2 - 11	42.0	134.8	16.0	120.0		70

A-20310
B-20310
 BSP BANJO

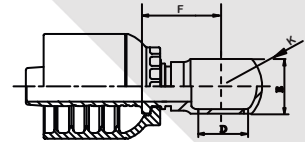

PART. REF. A	PART. REF. B	HOSE BORE			THREAD	DIMENSIONS				
		DN	INCH	SIZE	BOLT	B	F	D	E	K
A-20310 - 03 - 02		5	3/16	- 03	1/8 - 28	3.1	18.0	9.9	16.0	22.0
A-20310 - 04 - 02		6	1/4	- 04	1/8 - 28	4.1	18.0	9.9	16.0	22.0
A-20310 - 04 - 04		6	1/4	- 04	1/4 - 19	4.1	22.0	13.3	14.0	24.0
A-20310 - 04 - 06		6	1/4	- 04	3/8 - 19	4.1	21.0	16.7	18.0	28.0
A-20310 - 06 - 04	B-20310 - 06 - 04	10	3/8	- 06	1/4 - 19	*	*	*	*	*
A-20310 - 06 - 06	B-20310 - 06 - 06	10	3/8	- 06	3/8 - 19	7.0	24.1	16.7	18.0	28.0
A-20310 - 06 - 08	B-20310 - 06 - 08	10	3/8	- 06	1/2 - 14	7.0	27.1	21.2	22.0	35.0
A-20310 - 08 - 06	B-20310 - 08 - 06	12	1/2	- 08	3/8 - 19	*	*	*	*	*
A-20310 - 08 - 08	B-20310 - 08 - 08	12	1/2	- 08	1/2 - 14	9.5	27.5	21.2	22.0	35.0
A-20310 - 10 - 10	B-20310 - 10 - 10	16	5/8	- 10	5/8 - 14	12.0	28.2	23.0	23.5	38.0
A-20310 - 12 - 12	B-20310 - 12 - 12	19	3/4	- 12	3/4 - 14	15.0	36.5	26.7	29.0	45.0
A-20310 - 16 - 16	B-20310 - 16 - 16	25	1	- 16	1 - 11	20.0	44.5	33.4	36.0	54.0

A-11110

B-11110

(DIN20066/ISO 12151-2)

METRIC MALE 24° CONE SEAT
LIGHT TYPE DUTY

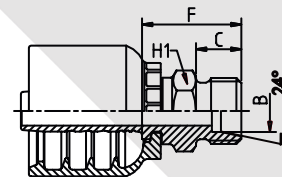

PART. REF. A	PART. REF. B	HOSE BORE			THREAD	TUBE	DIMENSIONS				
		DN	INCH	SIZE	LT. METRIC	MM	B	F	C	H1	
A-11110 - 04 - 12		6	1/4	- 04	M12X1.5	6.0	4.1	21.5	10.0		14
A-11110 - 04 - 14		6	1/4	- 04	M14X1.5	8.0	4.1	21.5	10.0		14
A-11110 - 04 - 16		6	1/4	- 04	M16X1.5	10.0	4.1	23.5	11.0		17
A-11110 - 04 - 18		6	1/4	- 04	M18X1.5	12.0	4.1	23.5	11.0		19
A-11110 - 05 - 16		8	5/16	- 05	M16X1.5	10.0	5.5	24.0	11.0		17
A-11110 - 05 - 18		8	5/16	- 05	M18X1.5	12.0	5.5	24.0	11.0		19
A-11110 - 06 - 16	B-11110 - 06 - 16	10	3/8	- 06	M16X1.5	10.0	7.0	24.1	11.0		17
A-11110 - 06 - 18	B-11110 - 06 - 18	10	3/8	- 06	M18X1.5	12.0	7.0	24.6	11.0		19
A-11110 - 06 - 22	B-11110 - 06 - 22	10	3/8	- 06	M22X1.5	15.0	7.0	25.6	12.0		22
A-11110 - 08 - 18	B-11110 - 08 - 18	12	1/2	- 08	M18X1.5	12.0	9.5	25.6	12.0		22
A-11110 - 08 - 22	B-11110 - 08 - 22	12	1/2	- 08	M22X1.5	15.0	12.0	27.0	12.0		22
A-11110 - 08 - 26	B-11110 - 08 - 26	12	1/2	- 08	M26X1.5	18.0	9.5	26.4	12.0		27
A-11110 - 10 - 22	B-11110 - 10 - 22	16	5/8	- 10	M22X1.5	15.0	12.0	27.0	12.0		22
A-11110 - 10 - 26	B-11110 - 10 - 26	16	5/8	- 10	M26X1.5	18.0	12.0	26.7	12.0		27
A-11110 - 10 - 30	B-11110 - 10 - 30	16	5/8	- 10	M30X2.0	22.0	15.0	28.5	14.0		30
A-11110 - 12 - 26	B-11110 - 12 - 26	19	3/4	- 12	M26X1.5	18.0	15.0	30.0	14.0		30
A-11110 - 12 - 30	B-11110 - 12 - 30	19	3/4	- 12	M30X2.0	22.0	15.0	30.0	14.0		30
A-11110 - 16 - 36	B-11110 - 16 - 36	25	1	- 16	M36X2.0	28.0	20.0	33.3	14.0		36
	B-11110 - 20 - 45	31	1.1/4	- 20	M45X2.0	35.0	25.0	40.5	16.0		46
	B-11110 - 24 - 52	38	1.1/2	- 24	M52X2.0	42.0	32.0	42.6	16.0		55

A-11210

B-11210

METRIC MALE 24° CONE SEAT
STRONG TYPE HEAVY DUTY

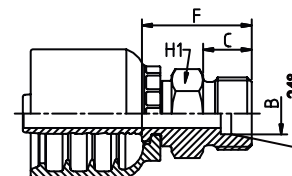

PART. REF. A	PART. REF. B	HOSE BORE			THREAD	TUBE	DIMENSIONS				
		DN	INCH	SIZE	HT. METRIC	MM	B	F	C	H1	
A-11210 - 04 - 16		6	1/4	- 04	M16X1.5	8.0	4.1	25.5	12.0		17
A-11210 - 04 - 18		6	1/4	- 04	M18X1.5	10.0	4.1	26.5	12.0		19
A-11210 - 04 - 20		6	1/4	- 04	M20X1.5	12.0	7.0	29.0	12.0		22
A-11210 - 05 - 18		8	5/16	- 05	M18X1.5	10.0	*	*	*		*
A-11210 - 05 - 20		8	5/16	- 05	M20X1.5	12.0	5.5	29.0	12.0		22
A-11210 - 06 - 18	B-11210 - 06 - 18	10	3/8	- 06	M18X1.5	10.0	7.0	27.1	12.0		19
A-11210 - 06 - 20	B-11210 - 06 - 20	10	3/8	- 06	M20X1.5	12.0	7.0	29.1	12.0		22
A-11210 - 06 - 22	B-11210 - 06 - 22	10	3/8	- 06	M22X1.5	14.0	7.0	31.1	14.0		22
A-11210 - 06 - 24	B-11210 - 06 - 24	10	3/8	- 06	M24X1.5	16.0	*	*	*		*
A-11210 - 08 - 22	B-11210 - 08 - 22	12	1/2	- 08	M22X1.5	14.0	9.3	31.5	14.0		22
A-11210 - 08 - 24	B-11210 - 08 - 24	12	1/2	- 08	M24X0.5	16.0	9.5	31.6	14.0		24
A-11210 - 10 - 30	B-11210 - 10 - 30	16	5/8	- 10	M30X2.0	20.0	12.0	35.7	16.0		30
A-11210 - 12 - 30	B-11210 - 12 - 30	19	3/4	- 12	M30X2.0	20.0	15.0	37.0	16.0		30
A-11210 - 12 - 36	B-11210 - 12 - 36	19	3/4	- 12	M36X2.0	25.0	15.0	41.0	18.0		36
A-11210 - 16 - 36	B-11210 - 16 - 36	25	1	- 16	M36X2.0	25.0	20.0	42.3	18.0		36
A-11210 - 16 - 42	B-11210 - 16 - 42	25	1	- 16	M42X2.0	30.0	20.0	44.3	20.0		46
	B-11210 - 20 - 52	31	1.1/4	- 20	M52X2.0	38.0	25.0	50.5	22.0		55

A-11710

B-11710

FRENCH METRIC MALE 24° CONE SEAT
MILLIMETRIC TYPE

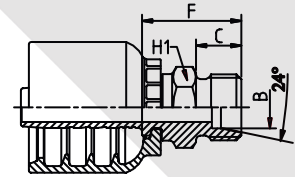

PART. REF. A	PART. REF. B	HOSE BORE			THREAD	TUBE	DIMENSIONS				
		DN	INCH	SIZE	FR. METRIC	MM	B	F	C	H1	
A-11710 - 10 -2718	B-11710 - 10 -2718	16	5/8	- 10	M27X1.5	18	12.5	28.7	14.0		28
A-11710 - 10 -2720	B-11710 - 10 -2720	16	5/8	- 10	M27X1.5	20	12.5	28.7	14.0		28
A-11710 - 12 - 30	B-11710 - 12 - 30	19	3/4	- 12	M30X1.5	22	15.0	30.0	14.0		30
A-11710 - 12 - 33	B-11710 - 12 - 33	19	3/4	- 12	M33X1.5	25	15.0	31.0	14.0		34

A-11810

B-11810

FRENCH METRIC MALE 24° CONE SEAT
GAZ TYPE

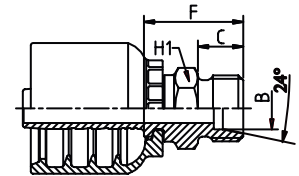

PART. REF. A	PART. REF. B	HOSE BORE			THREAD	TUBE	DIMENSIONS				
		DN	INCH	SIZE	FR. METRIC	MM	B	F	C	H1	
A-11810 - 05 - 20		8	5/16	- 05	M20X1.5	13.25	8.0	27.0	12.0		22
A-11810 - 06 - 20	B-11810 - 06 - 20	10	3/8	- 06	M20X1.5	13.25	8.0	27.6	12.0		22
A-11810 - 06 - 24	B-11810 - 06 - 24	10	3/8	- 06	M24X1.5	16.75	12.0	28.1	12.0		24
A-11810 - 08 - 24	B-11810 - 08 - 24	12	1/2	- 24	M24X1.5	16.75	12.0	28.4	12.0		24
A-11810 - 10 - 30	B-11810 - 10 - 30	16	5/8	- 10	M30X1.5	21.25	15.0	31.7	14.0		30
A-11810 - 12 - 36	B-11810 - 12 - 36	19	3/4	- 12	M36X1.5	26.75	21.0	34.0	14.0		36
A-11810 - 16 - 45	B-11810 - 16 - 45	25	1	- 16	M45X1.5	33.5	26.0	39.3	16.0		46

A-11813

B-11813

FRENCH METRIC MALE 24° CONE SEAT
"KOBELCO" TYPE

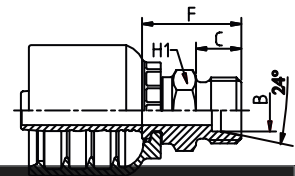

PART. REF. A	PART. REF. B	HOSE BORE			THREAD	TUBE	DIMENSIONS				
		DN	INCH	SIZE	KOBELCO	MM	B	F	C	H1	
A-11813 - 10 - 30	B-11813 - 10 - 30	16	5/8	- 10	M30X1.5	22	12.0	29.5	14.0		30
A-11813 - 12 - 30	B-11813 - 12 - 30	19	3/4	- 12	M30X1.5	22	15.0	30.0	14.0		30
A-11813 - 12 - 36	B-11813 - 12 - 36	19	3/4	- 12	M36X1.5	28	15.0	32.5	14.0		36
A-11813 - 16 - 45	B-11813 - 16 - 45	25	1	- 16	M45X1.5	35	20.0	39.7	16.0		46

A-20910
B-20910
 (DIN7642)
 METRIC BANJO

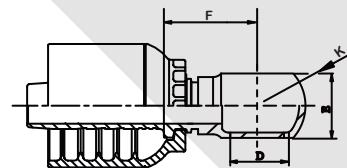

PART. REF. A	PART. REF. B	HOSE BORE			THREAD	DIMENSIONS					
		DN	INCH	SIZE	BOLT	B	F	D	E	K	
A-20910 - 03 - 10		5	3/16	- 03	M10X1.5	3.1	20.0	10.0	10.0	17.0	
A-20910 - 04 - 10		6	1/4	- 04	M10X1.5	4.1	20.5	10.0	10.0	17.0	
A-20910 - 04 - 12		6	1/4	- 04	M12X1.5	4.1	21.0	12.0	12.0	22.0	
A-20910 - 04 - 14		6	1/4	- 04	M14X1.5	4.1	21.5	14.0	14.0	24.0	
A-20910 - 05 - 14		8	5/16	- 05	M14X1.5	5.1	23.1	14.0	14.0	24.0	
A-20910 - 05 - 16		8	5/16	- 05	M16X1.5	*	*	*	*	*	
A-20910 - 06 - 14	B-20910 - 06 - 14	10	3/8	- 06	M14X1.5	7.0	24.1	14.0	14.0	24.0	
A-20910 - 06 - 16	B-20910 - 06 - 16	10	3/8	- 06	M16X1.5	7.0	24.1	16.0	18.0	28.0	
A-20910 - 06 - 18	B-20910 - 06 - 18	10	3/8	- 06	M18X1.5	7.0	27.1	18.0	20.0	32.0	
A-20910 - 08 - 18	B-20910 - 08 - 18	12	1/2	- 08	M18X1.5	9.5	27.5	18.0	20.0	32.0	
A-20910 - 08 - 22	B-20910 - 08 - 22	12	1/2	- 08	M22X1.5	9.5	27.5	22.0	22.0	35.0	
A-20910 - 10 - 22	B-20910 - 10 - 22	16	5/8	- 10	M22X1.5	12.0	28.2	22.0	23.5	38.0	
A-20910 - 12 - 26	B-20910 - 12 - 26	19	3/4	- 12	M26X1.5	15.0	36.5	26.0	29.0	45.0	

A-21512/13
B-21512/13
 (DIN20066/ISO 12151-2)
 O'RING METRIC FEMALE 24° CONE
 LIGHT TYPE DUTY
 [THRUST WIRE/SLIP-ON NUT]

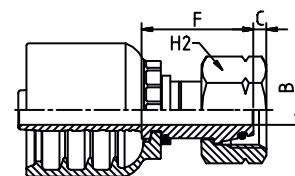

PART. REF. A	PART. REF. B	HOSE BORE			THREAD	TUBE	DIMENSIONS				
		DN	INCH	SIZE	LT. METRIC	MM	B	F	C	H2	
A-21513 - 03 - 12		5	3/16	- 03	M12X1.5	6	2.5	21.9	1.0		14
A-21512 - 04 - 12		6	1/4	- 04	M12X1.5	6	2.5	21.1	1.0		14
A-21513 - 04 - 14		6	1/4	- 04	M14X1.5	8	4.1	22.1	2.0		17
A-21513 - 04 - 16		6	1/4	- 04	M16X1.5	10	5.5	22.6	2.0		19
A-21513 - 04 - 18		6	1/4	- 04	M18X1.5	12	7.0	23.5	1.5		22
A-21512 - 05 - 14		8	5/16	- 05	M14X1.5	8	4.0	22.4	1.0		17
A-21513 - 05 - 16		8	5/16	- 05	M16X1.5	10	5.5	22.6	2.0		19
A-21513 - 05 - 18		8	5/16	- 05	M18X1.5	12	7.0	22.5	1.5		22
A-21512 - 06 - 16	B-21512 - 06 - 16	10	3/8	- 06	M16X1.5	10	5.5	23.1	1.5		19
A-21513 - 06 - 18	B-21513 - 06 - 18	10	3/8	- 06	M18X1.5	12	7.0	23.4	1.5		22
A-21513 - 06 - 22	B-21513 - 06 - 22	10	3/8	- 06	M22X1.5	15	9.5	25.0	2.5		27
A-21512 - 08 - 18	B-21512 - 08 - 18	12	1/2	- 08	M18X1.5	12	7.0	29.0	1.5		19
A-21513 - 08 - 22	B-21513 - 08 - 22	12	1/2	- 08	M22X1.5	15	9.5	25.4	2.5		27
A-21513 - 08 - 26	B-21513 - 08 - 26	12	1/2	- 08	M26X1.5	18	12.0	30.0	2.5		32
A-21513 - 10 - 26	B-21513 - 10 - 26	16	5/8	- 10	M26X1.5	18	12.0	29.0	2.5		32
A-21513 - 10 - 30	B-21513 - 10 - 30	16	5/8	- 10	M30X2.0	22	15.0	34.0	4.0		36
A-21512 - 12 - 26	B-21512 - 12 - 26	19	3/4	- 12	M26X1.5	18	12.0	31.1	2.0		32
A-21513 - 12 - 30	B-21513 - 12 - 30	19	3/4	- 12	M30X2.0	22	15.0	29.2	4.0		36
A-21513 - 12 - 36	B-21513 - 12 - 36	19	3/4	- 12	M36X2.0	28	20.0	32.5	4.0		41
A-21513 - 16 - 36	B-21513 - 16 - 36	25	1	- 16	M36X2.0	28	20.0	32.5	4.0		41
	B-21513 - 20 - 45	31	1.1/4	- 20	M45X2.0	35	25.0	35.0	5.0		50
	B-21513 - 24 - 52	38	1.1/2	- 24	M52X2.0	42	32.0	34.0	5.5		60

A-21542/43

B-21542/43

(DIN20066/ISO 12151-2)[THRUST WIRE/SLIP-ON NUT]
45° O’RING METRIC FEMALE 24° CONE
LIGHT TYPE DUTY

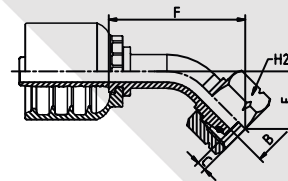

PART. REF. A	PART. REF. B	HOSE BORE			THREAD	TUBE	DIMENSIONS				
		DN	INCH	SIZE	LT. METRIC	MM	B	F	C	E	H2
A-21543 - 04 - 14		6	1/4	- 04	M14X1.5	8	4.1	38.0	2.0	16.5	17
A-21543 - 04 - 16		6	1/4	- 04	M16X1.5	10	5.5	38.0	2.0	17.0	19
A-21543 - 05 - 16		8	5/16	- 05	M16X1.5	10	5.5	41.5	2.0	17.5	19
A-21543 - 05 - 18		8	5/16	- 05	M18X1.5	12	7.0	38.5	2.3	17.5	22
A-21542 - 06 - 16	B-21542 - 06 - 16	10	3/8	- 06	M16X1.5	10	5.5	47.5	1.5	21.5	19
A-21543 - 06 - 18	B-21543 - 06 - 18	10	3/8	- 06	M18X1.5	12	7.0	43.5	1.5	17.0	22
A-21543 - 06 - 22	B-21543 - 06 - 22	10	3/8	- 06	M22X1.5	15	9.5	45.0	2.5	18.0	27
A-21543 - 08 - 22	B-21543 - 08 - 22	12	1/2	- 08	M22X1.5	15	9.5	52.0	2.5	19.5	27
A-21543 - 10 - 26	B-21543 - 10 - 26	16	5/8	- 10	M26X1.5	18	12.0	62.0	2.5	26.5	32
A-21543 - 12 - 30	B-21543 - 12 - 30	19	3/4	- 12	M30X2.0	22	15.0	71.0	4.0	28.5	36
A-21543 - 16 - 36	B-21543 - 16 - 36	25	1	- 16	M36X2.0	28	20.0	85.0	4.0	32.0	41
	B-21543 - 20 - 45	31	1.1/4	- 20	M45X2.0	35	25.0	99.5	5.0	36.0	50
	B-21543 - 24 - 52	38	1.1/2	- 24	M52X2.0	42	32.0	117.0	5.5	44.5	60

A-21592/93

B-21592/93

(DIN20066/ISO 12151-2)[THRUST WIRE/SLIP-ON NUT]
90° O’RING METRIC FEMALE 24° CONE
LIGHT TYPE DUTY

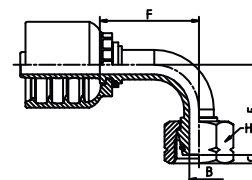

PART. REF. A	PART. REF. B	HOSE BORE			THREAD	TUBE	DIMENSIONS				
		DN	INCH	SIZE	LT. METRIC	MM	B	F	C	E	H2
A-21593 - 03 - 12		5	3/16	- 03	M12X1.5	6	2.5	26.0	1.0	30.0	14
A-21592 - 04 - 12		6	1/4	- 12	M12X1.5	6	2.5	28.5	1.0	32.5	14
A-21593 - 04 - 14		6	1/4	- 04	M14X1.5	8	4.1	29.5	2.0	31.5	17
A-21593 - 04 - 16		6	1/4	- 04	M16X1.5	10	5.5	29.5	2.0	32.0	19
A-21593 - 04 - 18		6	1/4	- 04	M18X1.5	12	7.0	29.5	1.5	33.0	22
A-21593 - 05 - 16		8	5/16	- 05	M16X1.5	10	5.5	32.0	2.0	32.5	19
A-21593 - 05 - 18		8	5/16	- 05	M18X1.5	12	7.0	32.0	1.5	32.5	22
A-21592 - 06 - 16	B-21592 - 06 - 16	10	3/8	- 06	M16X1.5	10	5.5	35.5	1.5	40.0	19
A-21593 - 06 - 18	B-21593 - 06 - 18	10	3/8	- 06	M18X1.5	12	7.0	36.5	1.5	33.5	22
A-21593 - 06 - 22	B-21593 - 06 - 22	10	3/8	- 06	M22X1.5	15	9.5	36.5	2.5	35.0	27
A-21592 - 08 - 18	B-21592 - 08 - 18	12	1/2	- 08	M18X1.5	12	7.0	44.0	1.0	48.0	22
A-21593 - 08 - 22	B-21593 - 08 - 22	12	1/2	- 08	M22X1.5	15	9.5	45.0	2.5	39.5	27
A-21593 - 08 - 26	B-21593 - 08 - 26	12	1/2	- 08	M26X1.5	18	12.0	45.0	2.5	40.0	32
A-21592 - 10 - 22	B-21592 - 10 - 22	16	5/8	- 10	M22X1.5	15	10.0	53.5	2.5	57.5	27
A-21593 - 10 - 30	B-21593 - 10 - 30	16	5/8	- 10	M30X2.0	22	15.0	51.5	4.0	54.0	36
A-21593 - 12 - 30	B-21593 - 12 - 30	19	3/4	- 12	M30X2.0	22	15.0	61.5	4.0	59.0	36
A-21593 - 16 - 36	B-21593 - 16 - 36	25	1	- 16	M36X2.0	28	20.0	76.5	4.0	41.0	41
	B-21593 - 20 - 45	31	1.1/4	- 20	M45X2.0	35	25.0	93.5	5.0	81.0	50
	B-21593 - 24 - 52	38	1.1/2	- 24	M52X2.0	42	32.0	107.5	5.5	98.0	60

A-21612/13

B-21612/13

(DIN20066/ISO 12151-2)[THRUST WIRE/SLIP-ON NUT]
O'RING METRIC FEMALE 24° CONE SEAT
STRONG TYPE HEAVY DUTY

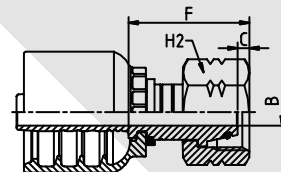

PART. REF. A	PART. REF. B	HOSE BORE			THREAD	TUBE	DIMENSIONS				
		DN	INCH	SIZE	HT. METRIC	MM	B	F	C	H2	
A-21613 - 03 - 16		5	3/16	- 03	M16X1.5	8	3.2	21.9	3.4		19
A-21613 - 04 - 14		6	1/4	- 04	M14X1.5	6	2.5	23.5	1.5		17
A-21613 - 04 - 16		6	1/4	- 04	M16X1.5	8	4.1	22.2	1.5		19
A-21613 - 04 - 18		6	1/4	- 04	M18X1.5	10	4.1	28.0	1.0		22
A-21613 - 04 - 20		6	1/4	- 04	M20X1.5	12	8.0	25.7	2.5		24
A-21613 - 05 - 18		8	5/16	- 05	M18X1.5	10	5.5	28.0	3.0		22
A-21613 - 05 - 20		8	5/16	- 05	M20X1.5	12	5.5	24.8	2.5		24
A-21613 - 06 - 18	B-21613 - 06 - 18	10	3/8	- 06	M18X1.5	10	5.0	28.5	1.0		22
A-21613 - 06 - 20	B-21613 - 06 - 20	10	3/8	- 06	M20X1.5	12	7.0	25.3	2.5		24
A-21613 - 06 - 22	B-21613 - 06 - 22	10	3/8	- 06	M22X1.5	14	7.0	32.6	2.5		27
A-21613 - 08 - 22	B-21613 - 08 - 22	12	1/2	- 08	M20X1.5	14	9.5	27.5	2.5		27
A-21613 - 08 - 24	B-21613 - 08 - 24	12	1/2	- 08	M24X1.5	16	9.5	26.7	3.0		30
A-21613 - 10 - 30	B-21613 - 10 - 30	16	5/8	- 10	M30X2.0	20	12.0	30.6	3.5		36
A-21612 - 12 - 30	B-21612 - 12 - 30	19	3/4	- 12	M30X2.0	20	15.0	33.5	3.5		36
A-21613 - 12 - 36	B-21613 - 12 - 36	19	3/4	- 12	M36X2.0	25	15.0	34.1	5.0		46
A-21612 - 16 - 36	B-21612 - 16 - 36	25	1	- 16	M36X2.0	25	20.0	35.3	5.0		46
A-21613 - 16 - 42	B-21613 - 16 - 42	25	1	- 16	M42X2.0	30	20.0	35.4	5.0		50
A-21613 - 16 - 52	B-21613 - 16 - 52	25	1	- 16	M52X2.0	38	*	*	*		*
	B-21613 - 20 - 52	31	1.1/4	- 20	M52X2.0	38	25.0	37.5	6.5		60
	B-21613 - 24 - 52	38	1.1/2	- 24	M52X2.0	38	32.0	49.6	6.5		60

A-21642/43

B-21642/43

(DIN20066/ISO 12151-2)[THRUST WIRE/SLIP-ON NUT]
45° O'RING METRIC FEMALE 24° CONE SEAT
STRONG TYPE HEAVY DUTY

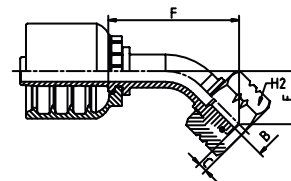

PART. REF. A	PART. REF. B	HOSE BORE			THREAD	TUBE	DIMENSIONS				
		DN	INCH	SIZE	HT. METRIC	MM	B	F	C	E	H2
A-21643 - 04 - 16		6	1/4	- 04	M16X1.5	8	4.1	36.0	1.5	15.0	19
A-21643 - 04 - 18		6	1/4	- 04	M18X1.5	10	4.1	37.5	1.0	16.5	22
A-21643 - 05 - 20		8	5/16	- 05	M20X1.5	12	5.5	42.5	2.5	18.5	24
A-21643 - 06 - 20	B-21643 - 06 - 20	10	3/8	- 06	M20X1.5	12	7.0	45.0	2.5	18.0	24
A-21643 - 06 - 22	B-21643 - 06 - 22	10	3/8	- 06	M22X1.5	14	7.0	46.5	2.5	19.5	27
A-21643 - 08 - 24	B-21643 - 08 - 24	12	1/2	- 08	M24X1.5	16	9.5	52.5	3.0	20.0	30
A-21643 - 10 - 30	B-21643 - 10 - 30	16	5/8	- 10	M30X2.0	20	15.0	65.5	3.5	29.5	36
A-21642 - 12 - 30	B-21642 - 12 - 30	19	3/4	- 12	M30X2.0	20	15.0	76.5	3.5	34.0	36
A-21643 - 12 - 36	B-21643 - 12 - 36	19	3/4	- 12	M36X2.0	25	15.0	75.0	5.0	32.5	41
A-21643 - 16 - 42	B-21643 - 16 - 42	25	1	- 16	M42X2.0	30	20.0	90.0	5.0	35.5	50
	B-21643 - 20 - 52	31	1.1/4	- 20	M52X2.0	38	25.0	103.0	6.5	39.5	60

A-21692/93

B-21692/93

(DIN20066/ISO 12151-2)[THRUST WIRE/SLIP-ON NUT]

90° O'RING METRIC FEMALE 24° CONE SEAT

STRONG TYPE HEAVY DUTY

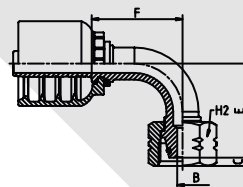

PART. REF. A	PART. REF. B	HOSE BORE			THREAD	TUBE	DIMENSIONS				
		DN	INCH	SIZE	HT. METRIC	MM	B	F	C	E	H2
A-21693 - 04 - 14		6	1/4	- 04	M14X1.5	6	2.5	29.5	1.5	32.5	17
A-21693 - 04 - 16		6	1/4	- 04	M16X1.5	8	4.1	29.5	1.5	29.5	19
A-21693 - 04 - 18		6	1/4	- 04	M18X1.5	10	4.1	29.5	1.0	31.0	22
A-21693 - 04 - 20		6	1/4	- 04	M20X1.5	12	8.0	29.5	2.0	34.5	24
A-21693 - 05 - 20		8	5/16	- 05	M20X1.5	12	5.5	32.0	2.5	34.0	24
A-21693 - 06 - 20	B-21693 - 06 - 20	10	3/8	- 06	M20X1.5	12	7.0	36.5	2.5	35.0	24
A-21693 - 06 - 22	B-21693 - 06 - 22	10	3/8	- 06	M22X1.5	14	7.0	36.5	2.5	37.0	27
A-21693 - 06 - 24	B-21693 - 06 - 24	10	3/8	- 06	M24X1.5	16	10.0	36.5	3.0	36.0	30
A-21693 - 08 - 22	B-21693 - 08 - 22	12	1/2	- 08	M22X1.5	14	9.5	44.0	2.5	48.5	27
A-21693 - 08 - 24	B-21693 - 08 - 24	12	1/2	- 08	M24X1.5	16	9.5	45.0	3.0	40.5	30
A-21693 - 10 - 30	B-21693 - 10 - 30	16	5/8	- 10	M30X2.0	20	12.0	51.5	3.5	57.5	36
A-21692 - 12 - 30	B-21692 - 12 - 30	19	3/4	- 12	M30X2.0	20	15.0	61.5	3.5	67.5	36
A-21693 - 12 - 36	B-21693 - 12 - 36	19	3/4	- 12	M36X2.0	25	15.0	61.5	5.0	64.5	41
A-21692 - 16 - 36	B-21692 - 16 - 36	25	1	- 16	M36X2.0	25	20.0	79.5	5.0	68.0	46
A-21693 - 16 - 42	B-21693 - 16 - 42	25	1	- 16	M42X2.0	30	20.0	79.0	5.0	74.5	50
	B-21693 - 20 - 52	31	1.1/4	- 20	M52X2.0	38	25.0	93.5	6.5	85.5	60

A-21713

B-21713

[THRUST WIRE/SLIP-ON NUT]

FRENCH METRIC FEMALE MILLIMETRIC

MILLIMETRIC TYPE

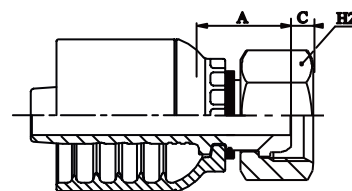

PART. REF. A	PART. REF. B	HOSE BORE			THREAD	TUBE	DIMENSIONS				
		DN	INCH	SIZE	FR. METRIC	MM	B	F	C	H2	
A-21713 - 10 - 2718	B-21713 - 10 - 2718	16	5/8	- 10	M27X1.5	18	12.5	22.2	5.1		32
A-21713 - 10 - 2720	B-21713 - 10 - 2720	16	5/8	- 10	M27X1.5	20	12.5	22.2	5.1		32
A-21713 - 12 - 30	B-21713 - 12 - 30	19	3/4	- 12	M30X1.5	22	15.0	25.5	4.1		36
A-21713 - 12 - 33	B-21713 - 12 - 33	19	3/4	- 12	M33X1.5	25	15.0	25.5	4.1		38
A-21713 - 16 - 36	B-21713 - 16 - 36	25	1	- 16	M36X1.5	28	19.8	27.8	4.8		41
A-21713 - 16 - 39	B-21713 - 16 - 39	25	1	- 16	M39X1.5	30	19.8	28.3	4.3		46

A-21813

B-21813

[THRUST WIRE]

FRENCH METRIC FEMALE

GAZ TYPE

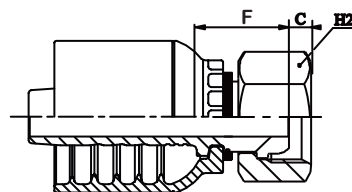

PART. REF. A	PART. REF. B	HOSE BORE			THREAD	TUBE	DIMENSIONS				
		DN	INCH	SIZE	FR. METRIC	MM	B	F	C	H2	
A-21813 - 04 - 20		6	1/4	- 04	M20X1.5	13.25	7.0	22.1	4.3		24
A-21813 - 06 - 20	B-21813 - 06 - 20	10	3/8	- 06	M20X1.5	13.25	7.0	22.6	4.3		24
A-21813 - 06 - 24	B-21813 - 06 - 24	10	3/8	- 06	M24X1.5	16.75	9.3	25.6	4.0		30
A-21813 - 08 - 24	B-21813 - 08 - 24	12	1/2	- 08	M24X1.5	16.75	9.3	26.5	4.0		30
A-21813 - 08 - 30	B-21813 - 08 - 30	12	1/2	- 08	M30X1.5	21.25	12.5	23.6	5.1		36
A-21813 - 10 - 30	B-21813 - 10 - 30	16	5/8	- 10	M30X1.5	21.25	12.5	23.7	5.1		36
A-21813 - 12 - 36	B-21813 - 12 - 36	19	3/4	- 12	M36X1.5	26.75	15.0	27.0	4.8		41
A-21813 - 16 - 45	B-21813 - 16 - 45	25	1	- 16	M45X1.5	33.5	19.8	26.8	4.6		50

A-21893

B-21893

[THRUST WIRE]

90° FRENCH METRIC FEMALE
GAZ TYPE

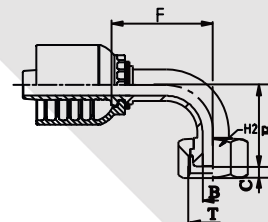

PART. REF. A	PART. REF. B	HOSE BORE			THREAD	TUBE	DIMENSIONS				
		DN	INCH	SIZE	FR. METRIC	MM	B	F	C	E	H2
A-21893 - 06 - 20	B-21893 - 06 - 20	10	3/8	- 06	M20X1.5	13.25	7.0	36.5	4.3	33.5	24
A-21893 - 08 - 24	B-21893 - 08 - 24	12	1/2	- 08	M24X1.5	16.75	12.0	45.0	4.0	41.0	30
A-21893 - 10 - 30	B-21893 - 10 - 30	16	5/8	- 10	M30X1.5	21.25	12.5	51.5	5.1	53.5	36
A-21893 - 12 - 36	B-21893 - 12 - 36	19	3/4	- 12	M36X1.5	26.75	15.0	61.5	4.8	60.0	41

A-22010

B-22010

(DIN2353/ISO 8434-1)

METRIC STANDPIPE STRAIGHT

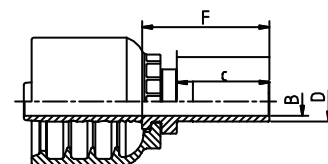

PART. REF. A	PART. REF. B	HOSE BORE			TUBE	DIMENSIONS				
		DN	INCH	SIZE	D	B	F	C		
A-22010 - 03 - 06		5	3/16	- 03	6	3.1	28.6	22.0		
A-22010 - 03 - 08		5	3/16	- 03	8	3.0	30.6	24.0		
A-22010 - 04 - 06		6	1/4	- 04	6	4.1	29.5	20.0		
A-22010 - 04 - 08		6	1/4	- 04	8	4.1	31.5	24.0		
A-22010 - 04 - 10		6	1/4	- 04	10	4.1	33.5	26.0		
A-22010 - 04 - 12		6	1/4	- 04	12	7.0	33.5	26.0		
A-22010 - 05 - 10		8	5/16	- 05	10	7.0	30.5	23.0		
A-22010 - 05 - 12		8	5/16	- 05	12	7.0	33.5	26.0		
A-22010 - 06 - 10	B-22010 - 06 - 10	10	3/8	- 06	10	7.0	30.6	20.0		
A-22010 - 06 - 12	B-22010 - 06 - 12	10	3/8	- 06	12	7.0	30.6	23.0		
A-22010 - 06 - 14	B-22010 - 06 - 14	10	3/8	- 06	14	8.0	36.6	29.0		
A-22010 - 08 - 12	B-22010 - 08 - 12	12	1/2	- 08	12	9.5	30.9	21.0		
A-22010 - 08 - 14	B-22010 - 08 - 14	12	1/2	- 08	14	9.3	36.9	29.0		
A-22010 - 08 - 15	B-22010 - 08 - 15	12	1/2	- 08	15	9.5	32.9	24.0		
A-22010 - 08 - 16	B-22010 - 08 - 16	12	1/2	- 08	16	9.5	37.9	29.0		
A-22010 - 08 - 18	B-22010 - 08 - 18	12	1/2	- 08	18	9.5	33.9	25.0		
A-22010 - 10 - 18	B-22010 - 10 - 18	16	5/8	- 10	18	12.5	34.2	26.0		
A-22010 - 10 - 20	B-22010 - 10 - 20	16	5/8	- 10	20	12.5	44.2	20.0		
A-22010 - 10 - 22	B-22010 - 10 - 22	16	5/8	- 10	22	15.0	36.2	22.0		
A-22010 - 12 - 18	B-22010 - 12 - 18	19	3/4	- 12	18	15.0	36.2	24.0		
A-22010 - 12 - 20	B-22010 - 12 - 20	19	3/4	- 12	20	15.0	46.0	36.0		
A-22010 - 12 - 22	B-22010 - 12 - 22	19	3/4	- 12	22	15.0	38.0	28.0		
A-22010 - 12 - 25	B-22010 - 12 - 25	19	3/4	- 12	25	15.0	50.0	40.0		
A-22010 - 16 - 25	B-22010 - 16 - 25	25	1	- 16	25	20.0	53.0	40.0		
A-22010 - 16 - 28	B-22010 - 16 - 28	25	1	- 16	28	20.0	41.3	28.0		
A-22010 - 16 - 30	B-22010 - 16 - 30	25	1	- 16	30	20.0	55.3	30.0		
A-22010 - 16 - 38	B-22010 - 16 - 38	25	1	- 16	38	26.0	61.3	50.0		
	B-22010 - 20 - 30	31	1.1/4	- 20	30	20.5	56.5	30.0		
	B-22010 - 20 - 35	31	1.1/4	- 20	35	25.0	48.5	36.0		
	B-22010 - 20 - 38	31	1.1/4	- 20	38	26.0	62.5	38.0		
	B-22010 - 24 - 38	38	1.1/2	- 24	38	26.0	62.6	50.0		
	B-22010 - 24 - 42	38	1.1/2	- 24	42	32.0	52.6	40.0		

A-22040

B-22040

(DIN2353/ISO 8434-1)
45° METRIC STANDPIPE

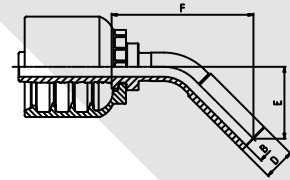

PART. REF. A	PART. REF. B	HOSE BORE			TUBE	DIMENSIONS				
		DN	INCH	SIZE	D	B	F	E		
A-22040 - 04 - 06		6	1/4	- 04	6	4.1	45.5	24.0		
A-22040 - 04 - 08		6	1/4	- 04	8	4.1	49.0	27.0		
A-22040 - 04 - 10		6	1/4	- 04	10	6.0	44.0	24.0		
A-22040 - 05 - 10		8	5/16	- 05	10	7.0	44.5	22.5		
A-22040 - 06 - 10	B-22040 - 06 - 10	10	3/8	- 06	10	7.0	51.0	26.5		
A-22040 - 06 - 12	B-22040 - 06 - 12	10	3/8	- 06	12	8.0	49.5	25.0		
A-22040 - 06 - 14	B-22040 - 06 - 14	10	3/8	- 06	14	9.3	54.5	29.0		
A-22040 - 08 - 14	B-22040 - 08 - 14	12	1/2	- 08	14	*	*	*		
A-22040 - 08 - 15	B-22040 - 08 - 15	12	1/2	- 08	15	9.5	59.4	29.4		
A-22040 - 08 - 16	B-22040 - 08 - 16	12	1/2	- 08	16	9.5	66.0	35.0		
A-22040 - 10 - 18	B-22040 - 10 - 18	16	5/8	- 10	18	12.0	63.5	30.5		
A-22040 - 10 - 20	B-22040 - 10 - 20	16	5/8	- 10	20	12.0	85.0	40.0		
A-22040 - 12 - 22	B-22040 - 12 - 22	19	3/4	- 12	22	15.0	76.0	32.0		
A-22040 - 12 - 25	B-22040 - 12 - 25	19	3/4	- 12	25	15.0	91.4	46.9		
A-22040 - 16 - 25	B-22040 - 16 - 25	25	1	- 16	25	15.0	82.0	41.0		
A-22040 - 16 - 28	B-22040 - 16 - 28	25	1	- 16	28	20.0	95.0	42.0		

A-22090

B-22090

(DIN2353/ISO 8434-1)
90° METRIC STANDPIPE

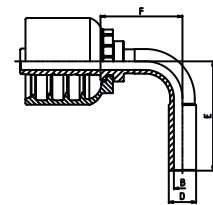

PART. REF. A	PART. REF. B	HOSE BORE			TUBE	DIMENSIONS				
		DN	INCH	SIZE	D	B	F	E		
A-22090 - 04 - 06		6	1/4	- 04	6	4.1	27.0	40.0		
A-22090 - 04 - 08		6	1/4	- 04	8	4.1	29.0	43.0		
A-22090 - 04 - 10		6	1/4	- 04	10	6.0	27.0	41.0		
A-22090 - 05 - 12		5	5/16	- 05	12	5.5	33.5	44.0		
A-22090 - 06 - 10	B-22090 - 06 - 10	10	3/8	- 06	10	7.0	34.0	47.5		
A-22090 - 06 - 12	B-22090 - 06 - 12	10	3/8	- 06	12	7.0	34.0	49.0		
A-22090 - 06 - 14	B-22090 - 06 - 14	10	3/8	- 06	14	9.3	42.0	53.5		
A-22090 - 08 - 14	B-22090 - 08 - 14	12	1/2	- 08	14	9.5	42.0	53.5		
A-22090 - 08 - 15	B-22090 - 08 - 15	12	1/2	- 08	15	10.5	42.0	52.0		
A-22090 - 08 - 16	B-22090 - 08 - 16	12	1/2	- 08	16	10.5	43.0	55.0		
A-22090 - 08 - 18	B-22090 - 08 - 18	12	1/2	- 08	18	9.5	48.5	58.0		
A-22090 - 10 - 18	B-22090 - 10 - 18	16	5/8	- 10	18	12.5	49.0	59.0		
A-22090 - 10 - 20	B-22090 - 10 - 20	16	5/8	- 10	20	12.5	49.0	66.5		
A-22090 - 10 - 22	B-22090 - 10 - 22	16	5/8	- 10	22	12.0	55.0	72.0		
A-22090 - 12 - 20	B-22090 - 12 - 20	19	3/4	- 12	20	15.0	54.5	69.0		
A-22090 - 12 - 22	B-22090 - 12 - 22	19	3/4	- 12	22	15.0	54.5	63.0		
A-22090 - 12 - 25	B-22090 - 12 - 25	19	3/4	- 12	25	15.0	60.0	80.0		
A-22090 - 16 - 25	B-22090 - 16 - 25	25	1	- 16	25	20.0	70.0	90.0		
A-22090 - 16 - 28	B-22090 - 16 - 28	25	1	- 16	28	19.8	67.5	75.0		
A-22090 - 16 - 30	B-22090 - 16 - 30	25	1	- 16	30	20.0	72.5	95.0		
	B-22090 - 20 - 35	31	1.1/4	- 20	35	26.0	80.5	94.0		

A-11310

B-11310

SAE FLARELESS MALE ASSEMBLY

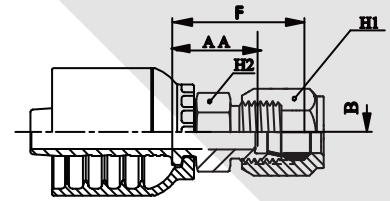

PART. REF. A	PART. REF. B	HOSE BORE			THREAD	TUBE	DIMENSIONS				
		DN	INCH	SIZE	ERMETO	INCH	B	F	AA	H1	H2
A-11310 - 04 - 04		6	1/4	- 04	7/16 - 20	1/4	4.1	27.0	20.9	14	12
A-11310 - 04 - 05		6	1/4	- 04	1/2 - 20	5/16	6.0	24.0	17.5	16	14
A-11310 - 06 - 04	B-11310 - 06 - 04	10	3/8	- 04	7/16 - 20	1/4	4.0	27.1	21.0	14	17
A-11310 - 06 - 05	B-11310 - 06 - 05	10	3/8	- 04	1/2 - 20	5/16	6.0	27.1	20.6	16	17
A-11310 - 06 - 06	B-11310 - 06 - 06	10	3/8	- 04	9/16 - 18	3/8	7.0	28.1	21.6	17.5	17
A-11310 - 06 - 08	B-11310 - 06 - 08	10	3/8	- 04	3/4 - 16	1/2	10.0	33.1	25.2	22	22
A-11310 - 08 - 08	B-11310 - 08 - 08	12	1/2	- 08	3/4 - 16	1/2	9.5	33.0	25.1	22	22
A-11310 - 08 - 10	B-11310 - 08 - 10	12	1/2	- 08	7/8 - 14	5/8	12.5	34.5	25.5	25.5	22
A-11310 - 12 - 12	B-11310 - 12 - 12	19	3/4	- 12	1.1/16 - 12	3/4	15.0	39.0	30.0	32	32

A-12610

B-12610

(SAE J516)

SAE MALE 45° CONE SEAT

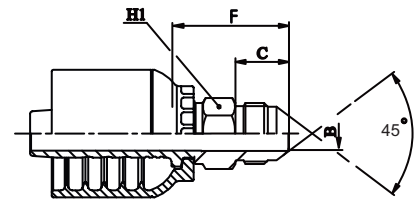

PART. REF. A	PART. REF. B	HOSE BORE			THREAD	DIMENSIONS				
		DN	INCH	SIZE	SAE 45°	B	F	C	H1	
A-12610 - 06 - 06	B-12610 - 06 - 06	10	3/8	- 06	5/8 - 18	7.0	29.6	14.0		17
A-12610 - 12 - 12	B-12610 - 12 - 12	19	3/4	- 12	1.3/16 - 12	15.0	44.0	22.0		27

A-12910

B-12910

STRAIGHT MALE INVERTED FLARE

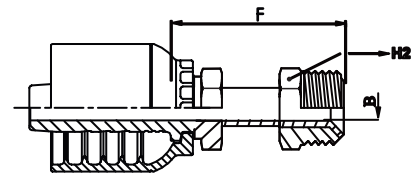

PART. REF. A	PART. REF. B	HOSE BORE			THREAD	TUBE	DIMENSIONS				
		DN	INCH	SIZE	INVERTED	INCH	B	F	H2	H2	
A-12910 - 04 - 04		6	1/4	- 04	7/16 - 20	1/4	3.9	43.5		12	
A-12910 - 04 - 05		6	1/4	- 04	7/16 - 20	5/16	4.6	46.0		14	
A-12910 - 05 - 04		8	5/16	- 04	1/2 - 20	1/4	3.9	45.0		12	
A-12910 - 06 - 05	B-12910 - 06 - 05	10	3/8	- 06	9/16 - 18	5/16	4.6	48.0		14	
A-12910 - 06 - 06	B-12910 - 06 - 06	10	3/8	- 06	9/16 - 18	3/8	6.2	50.0		17	
A-12910 - 08 - 08	B-12910 - 08 - 08	12	1/2	- 08	3/4 - 18	1/2	9.5	51.0		19	

A-12940

B-12940

45° MALE INVERTED FLARE

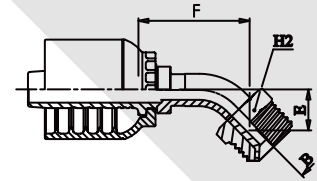

PART. REF. A	PART. REF. B	HOSE BORE			THREAD	TUBE	DIMENSIONS				
		DN	INCH	SIZE	INVERTED	INCH	B	F	E	H2	
A-12940 - 04 - 04		6	1/4	- 04	7/16 - 24	1/4	3.8	72.6	31.5		12
A-12940 - 04 - 05		6	1/4	- 04	7/16 - 24	5/16	4.6	75.0	40.0		14
A-12940 - 05 - 06		8	5/16	- 05	1/2 - 20	3/8	6.2	76.0	38.0		17
A-12940 - 06 - 04	B-12940 - 06 - 04	10	3/8	- 06	5/8 - 18	1/4	3.9	68.0	32.0		12
A-12940 - 06 - 05	B-12940 - 06 - 05	10	3/8	- 06	5/8 - 18	5/16	4.6	70.7	40.0		14
A-12940 - 06 - 06	B-12940 - 06 - 06	10	3/8	- 06	5/8 - 18	3/8	6.2	76.0	38.0		17
A-12940 - 08 - 08	B-12940 - 08 - 08	12	1/2	- 08	3/4 - 18	1/2	9.5	85.0	46.0		19

A-12990

B-12990

90° MALE INVERTED FLARE

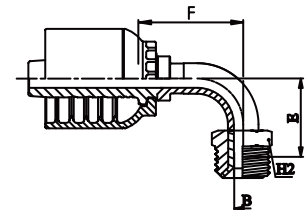

PART. REF. A	PART. REF. B	HOSE BORE			THREAD	TUBE	DIMENSIONS				
		DN	INCH	SIZE	INVERTED	INCH	B	F	E	H2	
A-12990 - 04 - 04		6	1/4	- 04	7/16 - 24	1/4	3.9	40.0	52.0		12
A-12990 - 04 - 05		6	1/4	- 04	7/16 - 24	5/16	4.6	38.0	55.0		14
A-12990 - 05 - 06		8	5/16	- 05	1/2 - 20	3/8	5.5	40.0	62.0		17
A-12990 - 06 - 04	B-12990 - 06 - 04	10	3/8	- 06	5/8 - 18	1/4	3.9	40.0	57.0		12
A-12990 - 06 - 05	B-12990 - 06 - 05	10	3/8	- 06	5/8 - 18	5/16	4.6	40.0	62.0		14
A-12990 - 06 - 06	B-12990 - 06 - 06	10	3/8	- 06	5/8 - 18	3/8	6.2	40.0	62.0		17
A-12990 - 08 - 08	B-12990 - 08 - 08	12	1/2	- 08	3/4 - 18	1/2	9.5	54.0	65.0		19

A-22612

B-22612

(SAE J516)

SAE FEMALE STRAIGHT FLARE 45°

[THRUST WIRE]

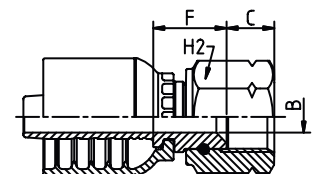

PART. REF. A	PART. REF. B	HOSE BORE			THREAD	TUBE	DIMENSIONS				
		DN	INCH	SIZE	SAE 45°	B	F	C	H2		
A-22612 - 06 - 06	B-22612 - 06 - 06	10	3/8	- 06	7/16 - 20	7	16.6	10.8			22
A-22612 - 12 - 12	B-22612 - 12 - 12	19	3/4	- 12	1.1/16 - 12	15	23.0	14.4			32

A-22642

B-22642

(SAE J516)

SAE FEMALE 45° FLARE

[THRUST WIRE]

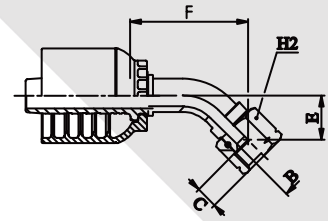

PART. REF. A	PART. REF. B	HOSE BORE			THREAD	DIMENSIONS					
		DN	INCH	SIZE	SAE 45°	B	F	C	E	H2	
A-22642 - 06 - 06	B-22642 - 06 - 06	10	3/8	- 06	5/8 - 18	7.0	42.0	10.8	16.5	22	

A-22692

B-22692

(SAE J516)

SAE FEMALE 90° FLARE

[THRUST WIRE]

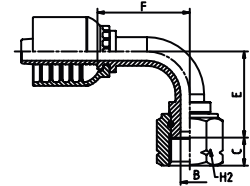

PART. REF. A	PART. REF. B	HOSE BORE			THREAD	DIMENSIONS					
		DN	INCH	SIZE	SAE 45°	B	F	C	E	H2	
A-22692 - 06 - 06	B-22692 - 06 - 06	10	3/8	- 06	5/8 - 18	7.0	35.5	10.8	33.0	22	
A-22692 - 12 - 12	B-22692 - 12 - 12	19	3/4	- 12	1.1/16 - 14	15.0	62.0	14.4	58.0	32	

A-23811

B-23811

(JIS B 8363)[CRIMP BACK]
FEMALE STRAIGHT "JIS" BSP STYLE 60° CONE SEAT (TOYOTA)

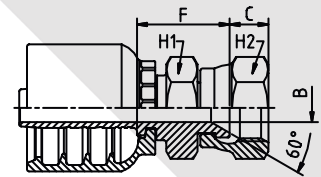

PART. REF. A	PART. REF. B	HOSE BORE			THREAD	DIMENSIONS					
		DN	INCH	SIZE	JIS	B	F	C	H1	H2	
A-23811 - 04 - 04		6	1/4	- 04	1/4 - 19	4.1	21.5	8.3		19	19
A-23811 - 06 - 06	B-23811 - 06 - 06	10	3/8	- 06	3/8 - 19	7.0	23.1	10.0		22	22
A-23811 - 08 - 08	B-23811 - 08 - 08	12	1/2	- 08	1/2 - 14	9.5	27.0	11.5		27	27
A-23811 - 10 - 10	B-23811 - 10 - 10	16	5/8	- 10	5/8 - 14	*	*	*		*	*
A-23811 - 12 - 12	B-23811 - 12 - 12	19	3/4	- 12	3/4 - 14	15.0	30.0	13.6		32	32
A-23811 - 16 - 16	B-23811 - 16 - 16	25	1	- 16	1 - 11	20.0	35.0	15.5		38	38

A-23891

B-23891

(JIS B 8363)[CRIMP BACK]
FEMALE 90° "JIS" BSP STYLE 60° CONE SEAT (TOYOTA)

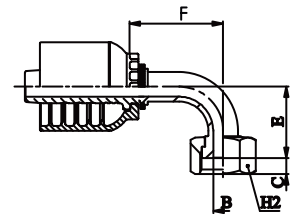

PART. REF. A	PART. REF. A	HOSE BORE			THREAD	DIMENSIONS					
		DN	INCH	SIZE	JIS	B	F	C	E	H1	
A-23891 - 04 - 04		6	1/4	- 04	1/4 - 19	4.1	32.0	8.3	27.0		19
A-23891 - 06 - 06	A-23891 - 06 - 06	10	3/8	- 06	3/8 - 19	7.0	37.0	10.0	38.0		22
A-23891 - 08 - 08	A-23891 - 08 - 08	12	1/2	- 08	1/2 - 14	9.5	47.5	11.5	40.0		27
A-23891 - 12 - 12	A-23891 - 12 - 12	19	3/4	- 12	3/4 - 14	15.0	61.0	13.6	58.4		32

A-24011

B-24011/12

(JIS B 8363)[CRIMP BACK]
JIS METRIC FEMALE 60° CONE SEAT (KOMATSU)

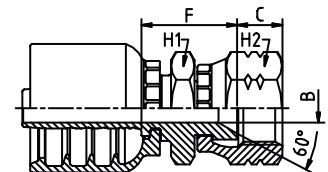

PART. REF. A	PART. REF. B	HOSE BORE			THREAD	DIMENSIONS					
		DN	INCH	SIZE	KOMATSU	B	F	C	H1	H2	
A-24011 - 04 - 14		6	1/4	- 04	M14X1.5	4.1	23.0	10.5		19	19
A-24011 - 04 - 18		6	1/4	- 04	M18X1.5	4.1	25.0	11.5		24	24
A-24011 - 05 - 16		8	5/16	- 05	M16X1.5	5.5	24.0	10.5		22	22
A-24011 - 06 - 14	B-24011 - 06 - 14	10	3/8	- 06	M14X1.5	7.0	23.3	10.5		19	19
A-24011 - 06 - 18	B-24011 - 06 - 18	10	3/8	- 06	M18X1.5	7.0	25.0	11.5		24	24
A-24011 - 08 - 22	B-24011 - 08 - 22	12	1/2	- 08	M22X1.5	9.5	27.7	14.0		27	27
A-24011 - 10 - 24	B-24011 - 10 - 24	16	5/8	- 10	M24X1.5	12.0	30.5	15.0		32	32
A-24011 - 12 - 30	B-24011 - 12 - 30	19	3/4	- 12	M30X1.5	15.0	31.3	18.0		36	36
A-24011 - 16 - 33	B-24011 - 16 - 33	25	1	- 16	M33X1.5	*	*	*		*	*
	B-24011 - 20 - 36	31	1.1/4	- 20	M36X1.5	25.0	37.0	20.0		46	46
	B-24012 - 24 - 42	38	1.1/2	- 24	M42X1.5	32.0	40.0	18.8		55	55

A-24041**B-24041****(JIS B 8363)[CRIMP BACK]**

45° JIS METRIC FEMALE 60° CONE SEAT (KOMATSU)

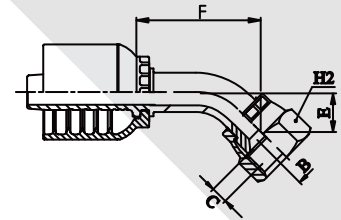

PART. REF. A	PART. REF. B	HOSE BORE			THREAD KOMATSU	DIMENSIONS					
		DN	INCH	SIZE		B	F	C	E	H2	
A-24041 - 04 - 14		6	1/4	- 04	M14X1.5	*	*	*	*		*
A-24041 - 04 - 18		6	1/4	- 04	M18X1.5	*	*	*	*		*
A-24041 - 06 - 18	B-24041 - 06 - 18	10	3/8	- 06	M18X1.5	*	*	*	*		*
A-24041 - 08 - 22	B-24041 - 08 - 22	12	1/2	- 08	M22X1.5	*	*	*	*		*
A-24041 - 08 - 24	B-24041 - 08 - 24	12	1/2	- 08	M24X1.5	*	*	*	*		*
A-24041 - 10 - 24	B-24041 - 10 - 24	16	5/8	- 10	M24X1.5	*	*	*	*		*
A-24041 - 12 - 30	B-24041 - 12 - 30	19	3/4	- 12	M30X1.5	*	*	*	*		*

A-24091**B-24091****(JIS B 8363)[CRIMP BACK]**

90° JIS METRIC FEMALE 60° CONE SEAT (KOMATSU)

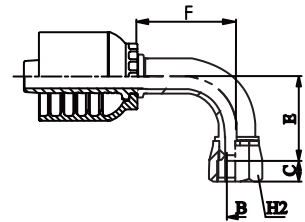

PART. REF. A	PART. REF. B	HOSE BORE			THREAD KOMATSU	DIMENSIONS					
		DN	INCH	SIZE		B	F	C	E	H2	
A-24091 - 04 - 14		6	1/4	- 04	M14X1.5	*	*	*	*		*
A-24091 - 04 - 16		6	1/4	- 04	M16X1.5	*	*	*	*		*
A-24091 - 04 - 18		6	1/4	- 04	M18X1.5	*	*	*	*		*
A-24091 - 06 - 18	B-24091 - 06 - 18	10	3/8	- 06	M18X1.5	*	*	*	*		*
A-24091 - 08 - 22	B-24091 - 08 - 22	12	1/2	- 08	M22X1.5	*	*	*	*		*
A-24091 - 10 - 24	B-24091 - 10 - 24	16	5/8	- 10	M24X1.5	*	*	*	*		*
A-24091 - 12 - 30	B-24091 - 12 - 30	19	3/4	- 12	M30X1.5	*	*	*	*		*

A-10050
B-10050
HOSE MENDER

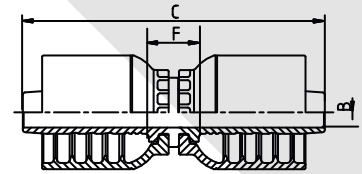

PART. REF. A	PART. REF. B	HOSE BORE			DIMENSIONS					
		DN	INCH	SIZE	B	F	C			
A-10050 - 04 - 04		6	1/4	- 04	4.1	14.0	69.0			
A-10050 - 05 - 05		8	5/16	- 05	5.5	14.0	69.7			
A-10050 - 06 - 06	B-10050 - 06 - 06	10	3/8	- 06	7.0	14.7	78.3			
A-10050 - 08 - 08	B-10050 - 08 - 08	12	1/2	- 08	9.5	15.8	91.8			
A-10050 - 10 - 10	B-10050 - 10 - 10	16	5/8	- 10	12.0	15.4	94.4			
A-10050 - 12 - 12	B-10050 - 12 - 12	19	3/4	- 12	15.0	18.5	98.5			
A-10050 - 16 - 16	B-10050 - 16 - 16	25	1	- 16	19.7	22.6	127.6			
	B-10050 - 20 - 20	31	1.1/4	- 20	25.0	23.0	146.0			
	B-10050 - 24 - 24	38	1.1/2	- 24	32.0	23.5	147.5			
	B-10050 - 32 - 32	51	2	- 32	*	*	*			

A-14913
MALE "KARCHER" STYLE

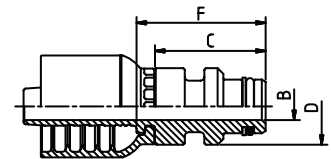

PART. REF. A	PART. REF. B	HOSE BORE			DIMENSIONS					
		DN	INCH	SIZE	B	F	C	D		
A-14913 - 04 - 22		6	1/4	- 04	*	*	*	*		
A-14913 - 05 - 22		8	5/16	- 05	*	*	*	*		

A-22810
[THRUST WIRE]
FEMALE GREASE THREAD

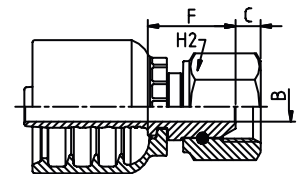

PART. REF. A	PART. REF. B	HOSE BORE			THREAD	DIMENSIONS				
		DN	INCH	SIZE	GREASE	B	F	C		H2
A-22810 - 03 - 02		5	3/16	- 03	1/4 - 28	*	*	*		*
A-22810 - 04 - 02		6	1/4	- 04	1/4 - 28	*	*	*		*

A-24913
B-24913
FEMALE "KARCHER" STYLE

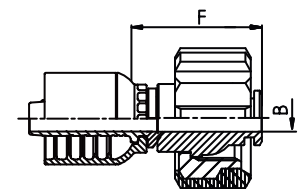

PART. REF. A	PART. REF. B	HOSE BORE			THREAD	DIMENSIONS				
		DN	INCH	SIZE	KARCHER	B	F			
A-24913 - 04 - 22		6	1/4	- 04	M22X1.5	4.1	34.5			
A-24913 - 05 - 22		8	5/16	- 05	M22X1.5	5.5	34.4			
A-24913 - 06 - 22	B-24913 - 06 - 22	10	3/8	- 06	M22X1.5	7.0	30.0			

A-12H10

B-12H10

STRAIGHT MALE "EASY PUSH" INSERT

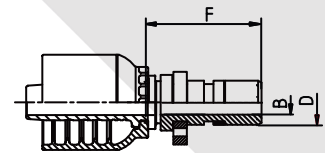

PART. REF. A	PART. REF. B	HOSE BORE			DIMENSIONS					
		DN	INCH	SIZE	B	F	D			
A-12H10 - 04 - 04		6	1/4	- 04	4.0	30.0	10.0			
A-12H10 - 04 - 06		6	1/4	- 04	7.0	34.0	13.0			
A-12H10 - 05 - 06		8	5/16	- 05	7.0	34.0	13.0			
A-12H10 - 06 - 04	B-12H10 - 06 - 04	10	3/8	- 06	4.0	30.5	10.0			
A-12H10 - 06 - 06	B-12H10 - 06 - 06	10	3/8	- 06	7.0	34.5	13.0			
A-12H10 - 06 - 08	B-12H10 - 06 - 08	10	3/8	- 06	9.3	34.5	16.0			
A-12H10 - 08 - 06	B-12H10 - 08 - 06	12	1/2	- 08	7.0	35.0	13.0			
A-12H10 - 08 - 08	B-12H10 - 08 - 08	12	1/2	- 08	9.3	35.0	16.0			
A-12H10 - 10 - 08	B-12H10 - 10 - 08	16	5/8	- 10	9.3	35.0	16.0			

A-12H40

B-12H40

45° MALE "EASY PUSH" INSERT

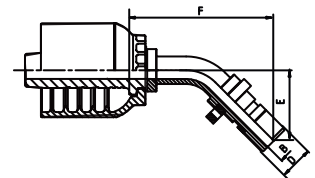

PART. REF. A	PART. REF. B	HOSE BORE			DIMENSIONS					
		DN	INCH	SIZE	B	F	D	E		
A-12H40 - 04 - 04		6	1/4	- 04	4.0	46.0	10.0	23.5		
A-12H40 - 04 - 06		6	1/4	- 04	7.0	52.0	13.0	27.0		
A-12H40 - 05 - 06	B-12H40 - 05 - 06	8	5/16	- 05	7.0	53.0	13.0	27.5		
A-12H40 - 06 - 04	B-12H40 - 06 - 04	10	3/8	- 06	4.0	47.0	10.0	23.5		
A-12H40 - 06 - 06	B-12H40 - 06 - 06	10	3/8	- 06	7.0	55.5	13.0	28.0		
A-12H40 - 08 - 08	B-12H40 - 08 - 08	12	1/2	- 08	9.3	61.5	16.0	30.0		

A-12H90

B-12H90

90° MALE "EASY PUSH" INSERT

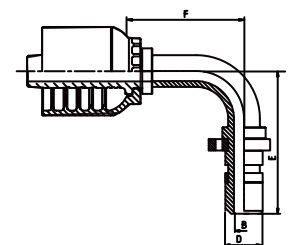

PART. REF. A	PART. REF. B	HOSE BORE			DIMENSIONS					
		DN	INCH	SIZE	B	F	D	E		
A-12H90 - 04 - 04		6	1/4	- 04	4.0	30.0	10.0	40.0		
A-12H90 - 04 - 06		6	1/4	- 04	7.0	32.0	13.0	45.0		
A-12H90 - 05 - 06		8	5/16	- 05	7.0	33.5	13.0	46.5		
A-12H90 - 06 - 04	B-12H90 - 06 - 04	10	3/8	- 06	4.0	30.5	10.0	40.0		
A-12H90 - 06 - 06	B-12H90 - 06 - 06	10	3/8	- 06	7.0	37.0	13.0	49.0		
A-12H90 - 08 - 08	B-12H90 - 08 - 08	12	1/2	- 08	9.3	44.0	16.0	55.0		

C-12810

(SAE J516)

NPTF MALE 30° CONE SEAT

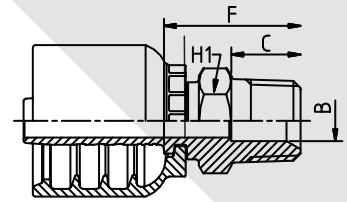

PART. REF. C	HOSE BORE			THREAD	DIMENSIONS				
	DN	INCH	SIZE	NPTF	B	F	C		H1
C-12810 - 06 - 04	10	3/8	- 06	1/4 - 18	7.0	30.5	14.5		19
C-12810 - 06 - 06	10	3/8	- 06	3/8 - 18	7.0	29.0	14.5		19
C-12810 - 06 - 08	10	3/8	- 06	1/2 - 14	7.0	34.8	19.3		22
C-12810 - 08 - 06	12	1/2	- 08	3/8 - 18	9.5	29.5	14.5		19
C-12810 - 08 - 08	12	1/2	- 08	1/2 - 14	9.5	35.2	19.3		22
C-12810 - 08 - 12	12	1/2	- 08	3/4 - 14	9.5	35.4	19.5		27
C-12810 - 10 - 08	16	5/8	- 10	1/2 - 14	12.0	30.7	19.3		24
C-12810 - 10 - 12	16	5/8	- 10	3/4 - 14	12.0	40.2	19.5		27
C-12810 - 12 - 08	19	3/4	- 12	1/2 - 14	*	*	*		*
C-12810 - 12 - 12	19	3/4	- 12	3/4 - 14	15.0	38.5	19.5		27
C-12810 - 12 - 16	19	3/4	- 12	1 - 11.5	20.0	46.5	25.5		36
C-12810 - 16 - 16	19	3/4	- 12	1 - 11.5	19.0	50.7	25.5		36
C-12810 - 16 - 20	19	3/4	- 12	1.1/4 - 11.5	25.0	52.7	25.0		46
C-12810 - 20 - 20	31	1.1/4	- 20	1.1/4 - 11.5	25.0	56.2	26.5		46
C-12810 - 24 - 24	38	1.1/2	- 24	1.1/2 - 11.5	31.0	63.5	27.5		50
C-12810 - 32 - 32	51	2	- 32	2 - 11.5	42.0	69.2	27.5		65

C-14110

(SAE J516)[THRUST WIRE]

NPTF SWIVEL MALE 30° CONE SEAT

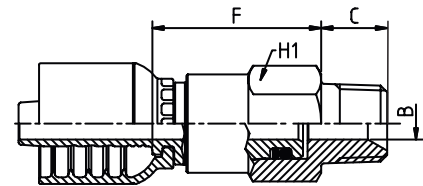

PART. REF. C	HOSE BORE			THREAD	DIMENSIONS				
	DN	INCH	SIZE	NPTF	B	F	C		H1
C-14110 - 06 - 04	10	3/8	- 06	1/4 - 18	4.1	51.4	19.5		19
C-14110 - 06 - 06	10	3/8	- 06	3/8 - 18	7.0	48.4	19.5		22
C-14110 - 06 - 08	10	3/8	- 06	1/4 - 14	7.0	55.3	27.6		27
C-14110 - 08 - 06	12	1/2	- 08	3/8 - 18	7.0	51.5	14.5		27
C-14110 - 08 - 08	12	1/2	- 08	1/4 - 14	9.5	55.6	27.6		27

C-14190

(SAE J516)[THRUST WIRE]

90° NPTF SWIVEL MALE 30° CONE SEAT

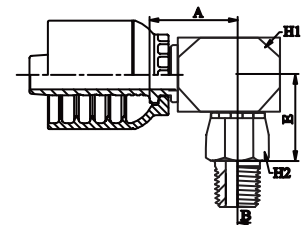

PART. REF. C	HOSE BORE			THREAD	DIMENSIONS				
	DN	INCH	SIZE	NPTF	B	F	E	H1	H2
C-14190 - 06 - 06	10	3/8	- 06	3/8 - 18	*	*	*	*	*
C-14190 - 08 - 08	12	1/2	- 08	1/4 - 14	*	*	*	*	*

C-22812

NPSM FEMALE 30° CONE SEAT SWIVEL

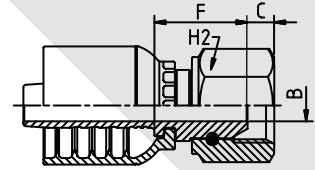

PART. REF. C	HOSE BORE			THREAD	DIMENSIONS				
	DN	INCH	SIZE	NPSM	B	F	C		H2
C-22812 - 06 - 04	10	3/8	- 06	1/4 - 18	7.0	22.8	4.2		19
C-22812 - 06 - 06	10	3/8	- 06	3/8 - 18	7.0	20.3	6.5		22
C-22812 - 06 - 08	10	3/8	- 06	1/2 - 14	9.5	23.8	6.5		27
C-22812 - 08 - 08	12	1/2	- 08	1/2 - 14	9.3	25.0	9.0		27

C-22814

NPTF FEMALE 30° FIX CONE SEAT

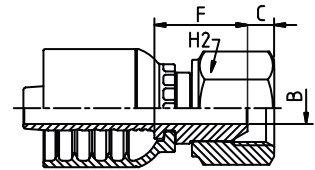

PART. REF. C	HOSE BORE			THREAD	DIMENSIONS				
	DN	INCH	SIZE	NPTF	B	F	C		H2
C-22814 - 06 - 04	10	3/8	- 06	1/4 - 18	7.0	16.3	12.0		19
C-22814 - 06 - 06	10	3/8	- 06	3/8 - 18	7.0	18.0	12.0		22
C-22814 - 06 - 08	10	3/8	- 06	1/2 - 14	7.0	16.0	17.0		25.4
C-22814 - 08 - 08	12	1/2	- 08	1/2 - 14	9.5	18.0	16.0		25.4

C-12510
 (SAE J516/J514)
 JIC MALE 37° CONE SEAT

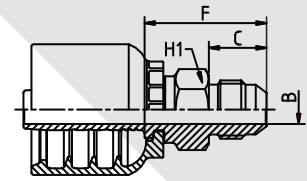

PART. REF. C	HOSE BORE			THREAD	DIMENSIONS				
	DN	INCH	SIZE	JIC	B	F	C		H1
C-12510 - 06 - 06	10	3/8	- 06	9/16 - 18	7.0	29.7	14.0		17
C-12510 - 06 - 08	10	3/8	- 06	3/4 - 16	7.0	34.7	16.5		19
C-12510 - 06 - 10	10	3/8	- 06	7/8 - 14	7.0	38.6	19.3		24
C-12510 - 08 - 06	12	1/2	- 08	9/16 - 18	9.5	32.0	14.0		22
C-12510 - 08 - 08	12	1/2	- 08	3/4 - 16	9.5	34.5	16.5		19
C-12510 - 08 - 10	12	1/2	- 08	7/8 - 14	9.5	39.2	19.3		24
C-12510 - 08 - 12	12	1/2	- 08	1.1/16 - 12	9.5	42.9	21.9		27
C-12510 - 10 - 08	16	5/8	- 10	3/4 - 16	*	*	*		*
C-12510 - 10 - 10	16	5/8	- 10	7/8 - 14	12.0	39.2	19.3		24
C-12510 - 10 - 12	16	5/8	- 10	1.1/16 - 12	12.0	42.7	21.9		27
C-12510 - 12 - 12	19	3/4	- 12	1.1/16 - 12	15.0	41.5	21.9		27
C-12510 - 16 - 16	25	1	- 16	1.5/16 - 12	19.0	48.3	23.1		36
C-12510 - 20 - 20	31	1.1/4	- 20	1.5/8 - 12	25.0	52.4	24.3		46
C-12510 - 24 - 24	38	1.1/2	- 24	1.7/8 - 12	31.0	64.0	27.5		50
C-12510 - 32 - 32	51	2	- 32	2 - 11.5	42.0	75.0	33.9		65

C-22541 (SEE P.126 FOR THRUST WIRE NUT)
 (SAE J516/J514)[CRIMP BACK]
 45° JIC FEMALE 37° CONE SEAT

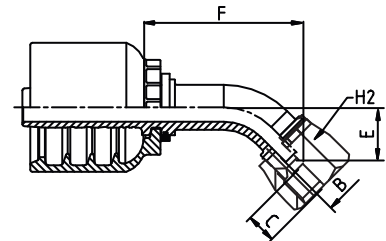

PART. REF. C	HOSE BORE			THREAD	DIMENSIONS				
	DN	INCH	SIZE	JIC	B	F	C	E	H1
C-22541 - 06 - 06	10	3/8	- 06	9/16 - 18	7.0	42.0	9.5	16.5	17.5
C-22541 - 06 - 08	10	3/8	- 06	3/4 - 16	*	*	*	*	*
C-22541 - 08 - 08	12	1/2	- 08	3/4 - 16	9.5	52.0	11.0	20.0	22
C-22541 - 08 - 10	12	1/2	- 08	7/8 - 14	9.5	49.5	12.0	17.0	25.4
C-22541 - 08 - 12	12	1/2	- 08	1.1/16 - 12	*	*	*	*	*
C-22541 - 10 - 10	16	5/8	- 10	7/8 - 14	*	*	*	*	*
C-22541 - 10 - 12	16	5/8	- 10	1.1/16 - 12	*	*	*	*	*

C-22582
 (SAE J516/J514)[THRUST WIRE]
 90° JIC FEMALE COMPACT ELBOW 37° CONE SEAT

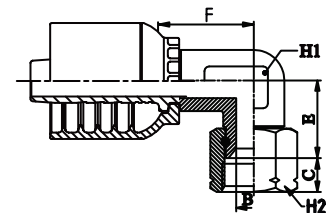

PART. REF. C	HOSE BORE			THREAD	DIMENSIONS					
	DN	INCH	SIZE	JIC	B	F	C	E	H1	H2
C-22582 - 06 - 06	10	3/8	- 06	9/16 - 18	7.0	23.1	9.5	24.0	19	19
C-22582 - 06 - 08	10	3/8	- 06	3/4 - 16	7.0	26.6	11.0	28.0	22	22
C-22582 - 08 - 08	12	1/2	- 08	3/4 - 16	9.5	23.0	11.0	28.0	22	22
C-22582 - 08 - 10	12	1/2	- 08	7/8 - 14	9.5	23.0	13.0	29.0	22	27

C-22591 (SEE P.127 FOR THRUST WIRE NUT)
 (SAE J516/J514)[CRIMP BACK]
 90° JIC FEMALE 37° CONE SEAT

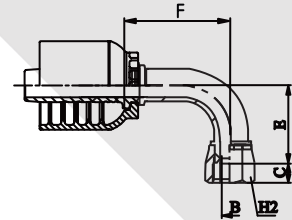

PART. REF. C	HOSE BORE			THREAD	DIMENSIONS					
	DN	INCH	SIZE	JIC	B	F	C	E	H2	
C-22591 - 06 - 06	10	3/8	- 06	9/16 - 18	7.0	35.5	10.0	32.5	17.5	
C-22591 - 06 - 08	10	3/8	- 06	3/4 - 16	*	*	*	*	*	
C-22591 - 08 - 08	12	1/2	- 08	3/4 - 16	9.5	46.5	11.0	42.0	22.2	
C-22591 - 08 - 10	12	1/2	- 08	7/8 - 14	9.5	45.0	12.0	36.0	25.4	
C-22591 - 08 - 12	12	1/2	- 08	1.1/16 - 12	*	*	*	*	*	
C-22591 - 10 - 10	16	5/8	- 10	7/8 - 14	12.0	53.5	12.0	52.5	25.4	
C-22591 - 10 - 12	16	5/8	- 10	1.1/16	*	*	*	*	*	

C-22711 (SEE P.126 FOR THRUST WIRE NUT)
 (SAE J516/J514)[CRIMP BACK]
 JIC FEMALE 37° CONE SEAT DOUBLE HEXAGON

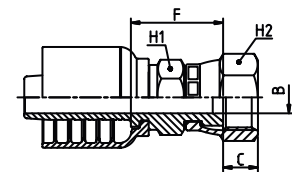

PART. REF. C	HOSE BORE			THREAD	DIMENSIONS					
	DN	INCH	SIZE	JIC	B	F	C	H1	H2	
C-22711 - 06 - 04	10	3/8	- 06	7/16 - 20	*	*	*	*	*	
C-22711 - 06 - 05	10	3/8	- 06	1/2 - 20	*	*	*	*	*	
C-22711 - 06 - 06	10	3/8	- 06	9/16 - 18	7.0	23.0	10.0	17	17.5	
C-22711 - 06 - 08	10	3/8	- 06	3/4 - 16	*	*	*	*	*	
C-22711 - 06 - 10	10	3/8	- 06	7/8 - 14	*	*	*	*	*	
C-22711 - 08 - 06	12	1/2	- 08	9/16 - 18	7.0	25.1	11.0	17	22.2	
C-22711 - 08 - 08	12	1/2	- 08	3/4 - 16	9.5	27.7	11.0	19	22.2	
C-22711 - 08 - 10	12	1/2	- 08	7/8 - 14	9.5	28.7	11.0	22	25.4	
C-22711 - 08 - 12	12	1/2	- 08	1.1/16 - 12	9.5	29.5	14.2	27	32	
C-22711 - 10 - 08	16	5/8	- 10	3/4 - 16	12.0	29.5	10.0	22	22	
C-22711 - 10 - 10	16	5/8	- 10	7/8 - 14	12.0	29.5	12.0	22	25.4	
C-22711 - 10 - 12	16	5/8	- 10	1.1/16 - 12	15.0	29.0	14.1	27	32	

C-22712

(SAE J516/J514)[THRUST WIRE]
JIC FEMALE 37° CONE SEAT DOUBLE HEXAGON

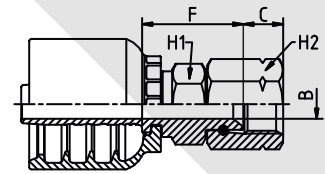

PART. REF. C	HOSE BORE			THREAD	DIMENSIONS					
	DN	INCH	SIZE	JIC	B	F	C	H1	H2	
C-22712 - 06 - 04	10	3/8	- 06	7/16 - 20	7.0	23.8	9.0	17	17	
C-22712 - 06 - 05	10	3/8	- 06	1/2 - 20	7.0	23.8	9.5	17	17	
C-22712 - 06 - 06	10	3/8	- 06	9/16 - 18	7.0	25.3	9.5	17	19	
C-22712 - 06 - 08	10	3/8	- 06	3/4 - 16	7.0	25.3	11.0	19	22	
C-22712 - 06 - 10	10	3/8	- 06	7/8 - 14	7.0	25.8	13.0	22	27	
C-22712 - 08 - 06	12	1/2	- 08	9/16 - 18	9.5	26.2	9.5	19	19	
C-22712 - 08 - 08	12	1/2	- 08	3/4 - 16	9.5	26.2	11.0	19	22	
C-22712 - 08 - 10	12	1/2	- 08	7/8 - 14	9.5	26.7	13.0	22	27	
C-22712 - 08 - 12	12	1/2	- 08	1.1/16 - 12	9.5	30.5	14.4	27	32	
C-22712 - 10 - 08	16	5/8	- 10	3/4 - 16	12.0	27.5	11.0	22	22	
C-22712 - 10 - 10	16	5/8	- 10	7/8 - 14	12.0	29.0	13.0	22	27	
C-22712 - 10 - 12	16	5/8	- 10	1.1/16 - 12	12.0	31.6	14.4	27	32	
C-22712 - 12 - 08	19	3/4	- 12	3/4 - 16	*	*	*	*	*	
C-22712 - 12 - 12	19	3/4	- 12	1.1/16 - 12	15.0	34.6	14.4	32	32	
C-22712 - 12 - 16	19	3/4	- 12	1.5/16 - 12	20.0	33.7	15.6	32	38	
C-22712 - 16 - 12	25	1	- 16	1.1/16 - 12	15.5	36.3	14.4	32	32	
C-22712 - 16 - 16	25	1	- 16	1.5/16 - 12	19.0	37.2	15.6	38	38	
C-22712 - 16 - 20	25	1	- 16	1.5/8 - 12	26.0	39.7	16.0	41	50	
C-22712 - 20 - 16	31	1.1/4	- 20	1.5/16 - 12	20.0	39.7	15.6	41	38	
C-22712 - 20 - 20	31	1.1/4	- 20	1.5/8 - 12	25.0	44.7	16.0	41	50	
C-22712 - 20 - 24	31	1.1/4	- 20	1.7/8 - 12	32.0	47.7	18.3	50	60	
C-22712 - 24 - 24	38	1.1/2	- 24	1.7/8 - 12	31.0	51.5	18.3	55	60	
C-22712 - 32 - 32	51	2	- 32	2.1/2 - 12	42.0	65.2	23.5	65	75	

C-22542/C-22742

(SAE J516/J514)[THRUST WIRE]
45° JIC FEMALE 37° CONE SEAT DOUBLE HEXAGON

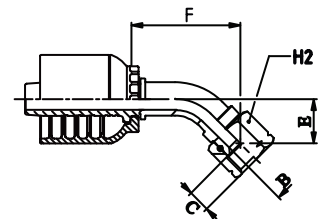

PART. REF. C	HOSE BORE			THREAD	DIMENSIONS					
	DN	INCH	SIZE	JIC	B	F	C	E	H2	
C-22542 - 06 - 06	10	3/8	- 06	9/16 - 18	7.0	42.0	9.5	16.5	19	
C-22542 - 06 - 08	10	3/8	- 06	3/4 - 16	9.9	45.8	11.0	14.0	22	
C-22542 - 06 - 10	10	3/8	- 06	7/8 - 14	7.0	42.5	13.0	15.5	27	
C-22542 - 08 - 08	12	1/2	- 08	3/4 - 16	9.5	52.0	11.0	20.0	22	
C-22542 - 08 - 10	12	1/2	- 08	7/8 - 14	9.5	49.5	13.0	17.0	27	
C-22542 - 08 - 12	12	1/2	- 08	1.1/16 - 12	9.5	50.0	14.4	17.0	32	
C-22542 - 10 - 10	16	5/8	- 10	7/8 - 14	12.0	62.0	25.5	25.5	27	
C-22542 - 10 - 12	16	5/8	- 10	1.1/16 - 12	12.0	60.0	14.4	24.0	32	
C-22742 - 12 - 12	19	3/4	- 12	1.1/16 - 12	15.0	75.4	14.4	29.2	32	
C-22742 - 16 - 16	25	1	- 16	1.5/16 - 12	19.0	84.4	15.6	32.8	38	
C-22742 - 20 - 20	31	1.1/4	- 20	1.5/8 - 12	25.0	96.5	16.0	32.0	50	
C-22742 - 24 - 24	38	1.1/2	- 24	1.7/8 - 12	31.0	121.6	18.3	42.0	60	
C-22742 - 32 - 32	51	2	- 32	2.1/2 - 12	42.0	150.3	23.5	54.6	75	

C-22592/C-22792

(SAE J516/J514)[THRUST WIRE]

90° JIC FEMALE 37° CONE SEAT DOUBLE HEXAGON

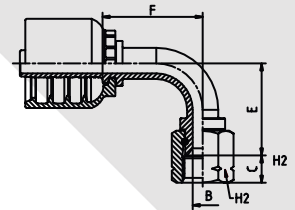

PART. REF. C	HOSE BORE			THREAD	DIMENSIONS				
	DN	INCH	SIZE	JIC	B	F	C	E	H2
C-22592 - 06 - 06	10	3/8	- 06	9/16 - 18	7.0	35.5	9.5	32.5	19
C-22592 - 06 - 08	10	3/8	- 06	3/4 - 16	7.0	36.5	11.0	29.5	22
C-22592 - 06 - 10	10	3/8	- 06	7/8 - 14	9.3	36.5	12.4	31.5	27
C-22592 - 08 - 06	12	1/2	- 08	9/16 - 18	9.5	36.5	9.5	33.0	19
C-22592 - 08 - 08	12	1/2	- 08	3/4 - 16	9.5	44.0	11.0	41.0	22
C-22592 - 08 - 10	12	1/2	- 08	7/8 - 14	9.5	45.0	13.0	36.0	27
C-22592 - 08 - 12	12	1/2	- 08	1.1/16	9.5	45.0	14.4	41.0	32
C-22592 - 10 - 10	16	5/8	- 10	7/8 - 14	12.0	53.5	13.0	52.5	27
C-22592 - 10 - 12	16	5/8	- 10	1.1/16	12.0	51.5	14.4	50.0	32
C-22792 - 12 - 12	19	3/4	- 12	1.1/16 - 12	15.0	65.5	14.4	58.0	32
C-22792 - 12 - 16	19	3/4	- 12	1.5/16 - 12	20.0	65.5	15.6	56.0	38
C-22792 - 16 - 16	25	1	- 16	1.5/16 - 12	19.0	76.2	15.6	71.0	38
C-22792 - 20 - 20	31	1.1/4	- 20	1.5/8 - 12	25.0	95.2	16.0	78.0	50
C-22792 - 20 - 24	31	1.1/4	- 20	1.7/8 - 12	32.0	95.2	18.3	68.0	55
C-22792 - 24 - 24	38	1.1/2	- 24	1.7/8 - 12	31.0	116.5	18.3	68.0	55
C-22792 - 32 - 32	51	2	- 32	2.1/2 - 12	42.0	144.5	23.5	140.0	75

C-24792

(SAE J516/J514)[THRUST WIRE]

90° JIC FEMALE LONG DROP ELBOW 37° CONE SEAT

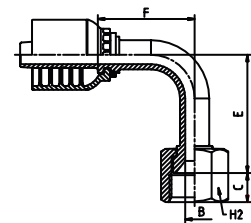

PART. REF. C	HOSE BORE			THREAD	DIMENSIONS				
	DN	INCH	SIZE	JIC	B	F	C	E	H2
C-24792 - 06 - 06	10	3/8	- 06	9/16 - 18	7.0	35.5	9.5	55.0	19
C-24792 - 06 - 08	10	3/8	- 06	3/4 - 16	7.0	61.5	11.0	61.5	22
C-24792 - 08 - 08	12	1/2	- 08	3/4 - 16	9.5	40.6	11.0	61.5	22
C-24792 - 08 - 10	12	1/2	- 05	7/8 - 14	9.5	45.0	13.0	65.0	27
C-24792 - 10 - 10	16	5/8	- 10	7/8 - 14	12.0	53.5	13.0	65.5	27
C-24792 - 12 - 12	19	3/4	- 12	1.1/16 - 12	*	*	*	*	*
C-24792 - 16 - 16	25	1	- 16	1.5/16 - 12	*	*	*	*	*
C-24792 - 20 - 20	31	1.1/4	- 20	1.5/8 - 12	*	*	*	*	*

C-13010

(SAE J516/J514)

SAE MALE O’RING BOSS TYPE

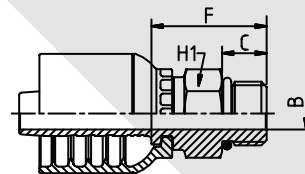

PART. REF. C	HOSE BORE			THREAD	DIMENSIONS					
	DN	INCH	SIZE	ORB	B	F	C			H1
C-13010 - 06 - 06	10	3/8	- 06	9/16 - 18	7.5	25.5	9.9			17
C-13010 - 06 - 08	10	3/8	- 06	3/4 - 16	7.0	28.6	11.1			22
C-13010 - 06 - 10	10	3/8	- 06	7/8 - 14	7.0	31.5	12.7			25
C-13010 - 08 - 08	12	1/2	- 08	3/4 - 16	9.5	28.9	11.1			22
C-13010 - 08 - 10	12	1/2	- 08	7/8 - 14	9.5	31.9	12.7			25
C-13010 - 08 - 12	12	1/2	- 08	1.1/16 - 12	9.5	38.5	15.1			32
C-13010 - 10 - 10	16	5/8	- 10	7/8 - 14	12.0	32.0	12.7			25
C-13010 - 10 - 12	16	5/8	- 10	1.1/16 - 12	12.0	37.7	15.1			32
C-13010 - 12 - 12	19	3/4	- 12	1.1/16 - 12	15.0	38.6	15.1			32
C-13010 - 12 - 16	19	3/4	- 12	1.5/16 - 12	20.0	42.1	15.1			41
C-13010 - 16 - 16	25	1	- 16	1.5/16 - 12	19.0	43.8	15.1			41
C-13010 - 20 - 20	31	1.1/4	- 20	1.5/8 - 12	25.0	48.3	15.1			50

C-14310

(SAE J516/J514)[THRUST WIRE]

SAE SWIVEL MALE O’RING BOSS TYPE

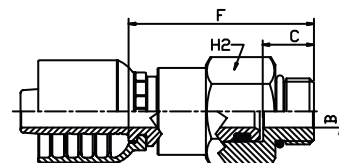

PART. REF. C	HOSE BORE			THREAD	DIMENSIONS					
	DN	INCH	SIZE	ORB	B	F	C			H2
C-14310 - 06 - 06	10	3/8	- 06	9/16 - 18	7.0	44.0	15.5			22
C-14310 - 06 - 08	10	3/8	- 06	3/4 - 16	7.0	*	22.1			27
C-14310 - 08 - 08	12	1/2	- 08	3/4 - 16	9.5	50.1	22.1			27
C-14310 - 08 - 10	12	1/2	- 08	7/8 - 14	9.5	52.8	24.8			27
C-14310 - 08 - 12	12	1/2	- 08	1.1/16 - 12	9.5	61.2	26.2			32
C-14310 - 10 - 10	16	5/8	- 10	7/8 - 14	12.0	55.8	24.8			27

C-14390

(SAE J516/J514)[THRUST WIRE]

90° SWIVEL MALE O’RING BOSS TYPE

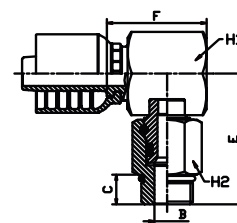

PART. REF. C	HOSE BORE			THREAD	DIMENSIONS					
	DN	INCH	SIZE	ORB	B	F	C	E	H1	H2
C-14390 - 06 - 06	10	3/8	- 06	9/16 - 18	7.0	22.8	15.5	46.5	22	22
C-14390 - 06 - 08	10	3/8	- 06	3/4 - 16	7.0	22.8	22.1	51.1	22	27
C-14390 - 08 - 08	12	1/2	- 08	3/4 - 16	9.5	23.0	22.1	51.1	22	27
C-14390 - 08 - 10	12	1/2	- 08	7/8 - 14	9.5	23.0	24.8	53.8	22	27
C-14390 - 10 - 10	16	5/8	- 10	7/8 - 14	12.0	28.0	19.1	52.6	27	27

C-12410
(SAE J1453)
MALE ORFS

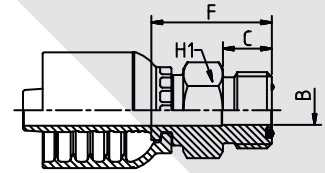

PART. REF. C	HOSE BORE			THREAD	DIMENSIONS				
	DN	INCH	SIZE	ORFS	B	F	C		H1
C-12410 - 06 - 06	10	3/8	- 06	11/16 - 16	7.0	27.6	11.0		19
C-12410 - 06 - 08	10	3/8	- 06	13/16 - 16	7.0	30.0	13.0		22
C-12410 - 06 - 10	10	3/8	- 06	1 - 14	*	*	*		*
C-12410 - 08 - 08	12	1/2	- 08	13/16 - 16	9.5	30.6	13.0		22
C-12410 - 08 - 10	12	1/2	- 08	1 - 14	9.5	35.0	15.5		27
C-12410 - 10 - 10	16	5/8	- 10	1 - 14	12.0	34.7	15.5		27
C-12410 - 10 - 12	16	5/8	- 10	1.3/16 - 12	12.0	37.5	17.0		32
C-12410 - 12 - 12	19	3/4	- 12	1.3/16 - 12	15.0	39.5	17.0		32
C-12410 - 16 - 16	25	1	- 16	1.7/16 - 12	19.0	48.2	17.5		41
C-12410 - 20 - 20	31	1.1/4	- 20	1.11/16 - 12	25.0	45.4	17.5		46
C-12410 - 24 - 24	38	1.1/2	- 24	2 - 12	30.0	51.9	17.5		55

C-22411/13
(SAE J516/J1453)[CRIMP BACK/SLIP-ON]
ORFS FEMALE

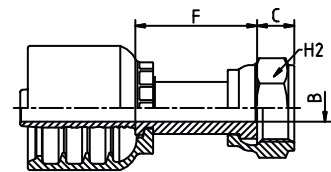

PART. REF. C	HOSE BORE			THREAD	DIMENSIONS				
	DN	INCH	SIZE	ORFS	B	F	C		H2
C-22411 - 06 - 04	10	3/8	- 06	9/16 - 18	7.0	29.0	8.5		17
C-22413 - 06 - 06	10	3/8	- 06	11/16 - 16	7.0	31.1	10.5		22
C-22413 - 06 - 08	10	3/8	- 06	13/16 - 16	7.0	35.6	10.0		24
C-22411 - 08 - 06	12	1/2	- 08	11/16 - 16	9.5	31.9	10.0		22
C-22413 - 08 - 08	12	1/2	- 08	13/16 - 16	9.5	35.9	10.0		24
C-22413 - 08 - 10	12	1/2	- 08	1 - 14	9.5	38.4	12.5		30
C-22413 - 08 - 12	12	1/2	- 08	1.3/16 - 12	9.5	41.9	14.5		36
C-22411 - 10 - 08	16	5/8	- 10	13/16 - 16	12.0	38.4	11.0		24
C-22413 - 10 - 10	16	5/8	- 10	1 - 14	12.0	38.7	12.5		30
C-22413 - 10 - 12	16	5/8	- 10	1.3/16 - 12	12.0	42.0	13.5		36
C-22413 - 12 - 12	19	3/4	- 12	1.3/16 - 12	15.0	44.0	13.5		36
C-22413 - 12 - 16	19	3/4	- 12	1.7/16 - 12	20.0	35.5	14.8		41
C-22413 - 16 - 12	25	1	- 16	1.3/16 - 12	19.0	43.7	14.5		36
C-22413 - 16 - 16	25	1	- 16	1.7/16 - 12	20.0	37.2	14.3		41
C-22413 - 16 - 20	25	1	- 16	1.11/16 - 12	19.0	50.2	13.5		50
C-22413 - 20 - 20	31	1.1/4	- 20	1.11/16 - 12	25.0	52.7	13.5		50
C-22413 - 20 - 24	31	1.1/4	- 20	2 - 12	30.0	40.2	13.5		60
C-22413 - 24 - 24	38	1.1/2	- 24	2 - 12	*	*	*		*

C-22441/43

(SAE J516/J1453)[CRIMP BACK/SLIP-ON]
45° MALE ORFS

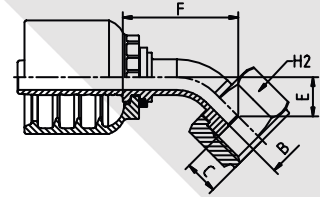

PART. REF. C	HOSE BORE			THREAD	DIMENSIONS					
	DN	INCH	SIZE	ORFS	B	F	C	E	H2	
C-22441 - 06 - 04	10	3/8	- 06	9/16 - 18	*	*	*	*	*	
C-22443 - 06 - 06	10	3/8	- 06	11/16 - 16	7.0	32.5	10.5	1.0	22	
C-22443 - 06 - 08	10	3/8	- 06	13/16 - 16	7.0	34.0	10.0	12.5	24	
C-22441 - 08 - 06	12	1/2	- 08	11/16 - 16	9.5	40.0	9.0	11.0	22	
C-22443 - 08 - 08	12	1/2	- 08	13/16 - 16	9.5	42.0	10.0	13.0	24	
C-22443 - 08 - 10	12	1/2	- 08	1 - 14	9.5	42.0	12.5	13.5	30	
C-22443 - 08 - 12	12	1/2	- 08	1.3/16 - 12	9.5	50.0	13.5	18.5	36	
C-22443 - 10 - 10	16	5/8	- 10	1 - 14	12.0	49.0	12.5	16.0	30	
C-22443 - 10 - 12	16	5/8	- 10	1.3/16 - 12	12.0	51.5	13.5	18.5	36	
C-22443 - 12 - 12	19	3/4	- 12	1.3/16 - 12	15.0	72.8	13.5	26.7	36	
C-22443 - 12 - 16	19	3/4	- 12	1.7/16 - 12	20.0	72.0	13.8	26.0	41	
C-22443 - 16 - 16	25	1	- 16	1.7/16 - 12	19.0	80.2	13.5	28.6	41	
C-22443 - 16 - 20	25	1	- 16	1.11/16 - 12	19.0	83.6	13.5	32.0	50	
C-22443 - 20 - 20	31	1.1/4	- 20	1.11/16 - 12	25.0	96.5	13.5	32.0	50	
C-22443 - 24 - 24	38	1.1/2	- 24	2 - 12	31.0	121.6	13.5	42.0	60	

C-22491/93

(SAE J516/J1453)[CRIMP BACK/SLIP-ON]
90° ORFS FEMALE

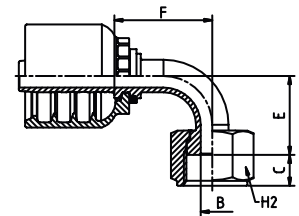

PART. REF. C	HOSE BORE			THREAD	DIMENSIONS					
	DN	INCH	SIZE	ORFS	B	F	C	E	H2	
C-22491 - 06 - 04	10	3/8	- 06	9/16 - 18	7.0	30.0	8.0	23.0	17	
C-22493 - 06 - 06	10	3/8	- 06	11/16 - 16	7.0	30.0	10.5	24.0	22	
C-22493 - 06 - 08	10	3/8	- 06	13/16 - 16	7.0	30.0	10.0	26.5	24	
C-22491 - 08 - 06	12	1/2	- 08	11/16 - 16	9.5	35.0	10.0	24.5	22	
C-22493 - 08 - 08	12	1/2	- 08	13/16 - 16	9.5	40.5	10.0	30.0	24	
C-22493 - 08 - 10	12	1/2	- 08	1 - 14	9.5	40.5	12.5	30.0	30	
C-22493 - 08 - 12	12	1/2	- 08	1.3/16 - 12	9.5	48.0	13.5	37.5	36	
C-22493 - 10 - 10	16	5/8	- 10	1 - 14	12.0	48.0	12.5	37.5	30	
C-22493 - 10 - 12	16	5/8	- 10	1.3/16 - 12	12.0	48.0	13.5	41.0	36	
C-22493 - 12 - 12	19	3/4	- 12	1.3/16 - 12	15.0	65.5	13.5	58.0	36	
C-22493 - 12 - 16	19	3/4	- 12	1.7/16 - 12	20.0	65.5	13.8	56.0	41	
C-22493 - 16 - 16	25	1	- 16	1.7/16 - 12	19.0	76.2	13.5	71.0	41	
C-22493 - 16 - 20	25	1	- 16	1.11/16 - 12	19.0	76.2	13.5	64.0	50	
C-22493 - 20 - 20	31	1.1/4	- 20	1.11/16 - 12	25.0	95.2	13.5	78.0	50	
C-22493 - 24 - 24	38	1.1/2	- 24	2 - 12	31.0	116.5	13.5	80.0	60	

C-24493

(SAE J516/J1453)[SLIP-ON]
90° FEMALE ORFS LONG DROP

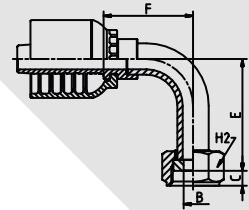

PART. REF. C	HOSE BORE			THREAD	DIMENSIONS					
	DN	INCH	SIZE	ORFS	B	F	C	E		H2
C-24493 - 06 - 06	10	3/8	- 06	11/16 - 16	7.0	31.5	9.5	53.5		22
C-24493 - 06 - 08	10	3/8	- 06	13/16 - 16	7.0	35.7	10.0	53.5		24
C-24493 - 08 - 08	12	1/2	- 08	13/16 - 16	9.5	40.5	10.0	63.5		24
C-24493 - 08 - 10	12	1/2	- 08	1 - 14	9.5	44.5	12.5	64.0		30
C-24493 - 10 - 10	16	5/8	- 10	1 - 14	12.0	48.0	12.5	69.0		30
C-24493 - 10 - 12	16	5/8	- 10	1.3/16 - 12	12.0	54.5	13.5	73.0		36

C-23311

(SAE J516/J518)

STRAIGHT SAE FLANGE 3000PSI
CODE 61

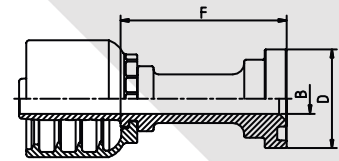

PART. REF. C	HOSE BORE			FLANGE	DIMENSIONS					
	DN	INCH	SIZE	CODE 61	B	F	D			
C-23311 - 08 - 08	12	1/2	- 08	1/2	9.5	50.9	30.2			
C-23311 - 08 - 12	12	1/2	- 08	3/4	9.5	57.7	38.1			
C-23311 - 10 - 12	16	5/8	- 10	3/4	15.0	65.7	38.1			
C-23311 - 12 - 12	19	3/4	- 12	3/4	14.0	49.5	38.1			
C-23311 - 12 - 16	19	3/4	- 12	1	14.0	52.5	44.5			
C-23311 - 16 - 12	25	1	- 16	3/4	19.0	51.2	38.1			
C-23311 - 16 - 16	25	1	- 16	1	19.0	54.2	44.5			
C-23311 - 16 - 20	25	1	- 16	1.1/4	19.0	59.2	50.8			
C-23311 - 20 - 16	31	1.1/4	- 20	1	25.0	56.7	44.5			
C-23311 - 20 - 20	31	1.1/4	- 20	1.1/4	25.0	61.4	50.8			
C-23311 - 20 - 24	31	1.1/4	- 20	1.1/2	25.0	71.7	60.3			
C-23311 - 24 - 24	38	1.1/2	- 20	1.1/2	31.0	76.5	60.3			
C-23311 - 24 - 32	38	1.1/2	- 20	2	31.0	78.5	71.4			
C-23311 - 32 - 32	51	2	- 32	2	42.0	80.7	71.4			

C-23321

(SAE J516/J518)

22.5° SAE FLANGE 3000PSI
CODE 61

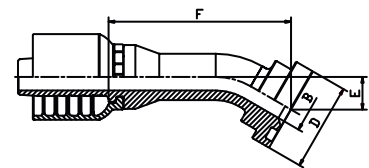

PART. REF. C	HOSE BORE			FLANGE	DIMENSIONS					
	DN	INCH	SIZE	CODE 61	B	F	D	E		
C-23321 - 08 - 08	12	1/2	- 08	1/2	9.3	63.9	30.3	8.0		
C-23321 - 08 - 12	12	1/2	- 08	3/4	*	*	*	*		
C-23321 - 12 - 12	19	3/4	- 12	3/4	14.0	63.6	38.1	11.0		
C-23321 - 12 - 16	19	3/4	- 12	1	14.0	70.9	44.5	14.0		
C-23321 - 16 - 16	25	1	- 16	1	19.0	76.4	44.5	14.0		
C-23321 - 20 - 20	31	1.1/4	- 20	1.1/4	25.0	89.4	50.8	12.0		
C-23321 - 24 - 24	38	1.1/2	- 24	1.1/2	31.0	109.5	60.3	18.0		
C-23321 - 32 - 32	51	2	- 32	2	42.0	130.9	71.4	22.0		

C-23331

(SAE J516/J518)

30° SAE FLANGE 3000PSI
CODE 61

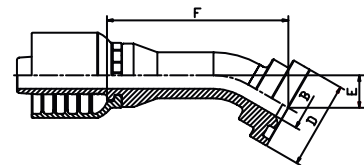

PART. REF. C	HOSE BORE			FLANGE	DIMENSIONS					
	DN	INCH	SIZE	CODE 61	B	F	D	E		
C-23331 - 08 - 08	12	1/2	- 08	1/2	9.5	62.6	30.2	12.0		
C-23331 - 12 - 12	19	3/4	- 12	3/4	14.0	67.1	38.1	16.0		
C-23331 - 16 - 16	25	1	- 16	1	19.0	78.4	44.5	19.0		
C-23331 - 16 - 20	25	1	- 16	1.1/4	19.0	83.6	50.8	22.0		
C-23331 - 20 - 20	31	1.1/4	- 20	1.1/4	25.0	94.9	50.8	22.0		
C-23331 - 24 - 24	38	1.1/2	- 24	1.1/2	31.0	122.3	60.3	30.0		
C-23331 - 32 - 32	51	2	- 32	2	42.0	138.9	71.4	32.0		

C-23341

(SAE J516/J518)
45° SAE FLANGE 3000PSI
CODE 61

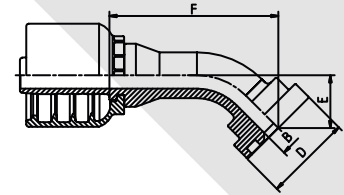

PART. REF. C	HOSE BORE			FLANGE	DIMENSIONS				
	DN	INCH	SIZE	CODE 61	B	F	D	E	
C-23341 - 08 - 08	12	1/2	- 08	1/2	9.5	58.5	30.2	18.5	
C-23341 - 08 - 12	12	1/2	- 08	1/2	9.5	59.5	38.1	19.0	
C-23341 - 10 - 12	16	5/8	- 10	3/4	15.0	61.0	38.1	22.0	
C-23341 - 12 - 12	19	3/4	- 12	3/4	14.0	70.2	38.1	26.0	
C-23341 - 12 - 16	19	3/4	- 12	1	14.0	76.2	44.5	32.0	
C-23341 - 16 - 16	25	1	- 16	1	19.0	83.6	44.5	32.0	
C-23341 - 16 - 20	25	1	- 16	1.1/4	19.0	89.6	50.8	38.0	
C-23341 - 20 - 20	31	1.1/4	- 20	1.1/4	25.0	102.5	50.8	38.0	
C-23341 - 20 - 24	31	1.1/4	- 20	1.1/2	25.0	108.5	60.3	44.0	
C-23341 - 24 - 24	38	1.1/2	- 24	1.1/2	31.0	123.6	60.3	44.0	
C-23341 - 24 - 32	38	1.1/2	- 24	2	31.0	135.6	71.4	56.0	
C-23341 - 32 - 32	51	2	- 32	2	42.0	151.7	71.4	56.0	

C-23361

(SAE J516/J518)
60° SAE FLANGE 3000PSI
CODE 61

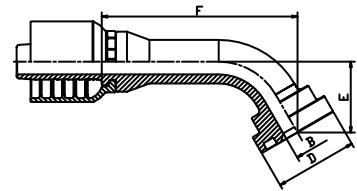

PART. REF. C	HOSE BORE			FLANGE	DIMENSIONS				
	DN	INCH	SIZE	CODE 61	B	F	D	E	
C-23361 - 08 - 08	12	1/2	- 08	1/2	9.3	71.5	30.2	25.8	
C-23361 - 08 - 12	12	1/2	- 08	3/4	15.0	72.5	38.1	26.5	
C-23361 - 12 - 12	19	3/4	- 12	3/4	14.0	70.9	38.1	34.5	
C-23361 - 12 - 16	19	3/4	- 12	1	14.0	74.9	44.5	44.0	
C-23361 - 16 - 16	25	1	- 16	1	19.0	83.6	44.5	44.0	
C-23361 - 20 - 20	31	1.1/4	- 20	1.1/4	25.0	104.8	50.8	55.0	
C-23361 - 24 - 24	38	1.1/2	- 24	1.1/2	31.0	126.8	60.3	64.0	
C-23361 - 32 - 32	51	2	- 32	2	42.0	157.2	71.4	83.0	

C-23371

(SAE J516/J518)
67.5° SAE FLANGE 3000PSI
CODE 61

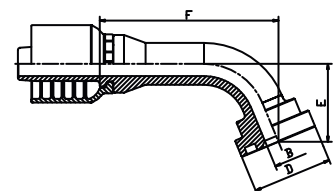

PART. REF. C	HOSE BORE			FLANGE	DIMENSIONS				
	DN	INCH	SIZE	CODE 61	B	F	D	E	
C-23371 - 08 - 08	12	1/2	- 08	1/2	9.3	67.9	30.2	29.3	
C-23371 - 12 - 12	19	3/4	- 12	3/4	14.0	70.0	38.1	42.0	
C-23371 - 12 - 16	19	3/4	- 12	1	14.0	73.7	44.5	51.0	
C-23371 - 16 - 16	25	1	- 16	1	19.0	83.4	44.5	51.0	
C-23371 - 20 - 20	31	1.1/4	- 20	1.1/4	25.0	104.3	50.8	64.0	
C-23371 - 24 - 24	38	1.1/2	- 24	1.1/2	31.0	126.3	60.3	74.0	
C-23371 - 32 - 32	51	2	- 32	2	42.0	157.0	71.4	97.0	

C-23391

(SAE J516/J518)

90° SAE FLANGE 3000PSI
CODE 61

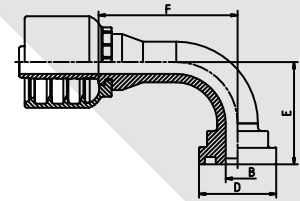

PART. REF. C	HOSE BORE			FLANGE	DIMENSIONS				
	DN	INCH	SIZE	CODE 61	B	F	D	E	
C-23391 - 08 - 08	12	1/2	- 08	1/2	9.5	54.5	30.2	41.0	
C-23391 - 08 - 12	12	1/2	- 08	3/4	9.5	54.5	38.1	41.0	
C-23391 - 10 - 12	16	5/8	- 10	3/4	12.0	56.0	38.1	47.5	
C-23391 - 12 - 12	19	3/4	- 12	3/4	14.0	63.5	38.1	58.0	
C-23391 - 12 - 16	19	3/4	- 12	1	14.0	63.5	44.5	55.0	
C-23391 - 16 - 16	25	1	- 16	1	19.0	76.2	44.5	70.0	
C-23391 - 16 - 20	25	1	- 16	1.1/4	19.0	76.2	50.8	65.0	
C-23391 - 20 - 20	31	1.1/4	- 20	1.1/4	25.0	95.2	50.8	75.0	
C-23391 - 20 - 24	31	1.1/4	- 20	1.1/2	25.0	95.2	60.3	75.0	
C-23391 - 24 - 20	38	1.1/2	- 24	1.1/4	31.0	116.5	50.8	95.0	
C-23391 - 24 - 24	38	1.1/2	- 24	1.1/2	31.0	116.5	60.3	90.0	
C-23391 - 24 - 32	38	1.1/2	- 24	2	31.0	116.5	71.4	95.0	
C-23391 - 32 - 32	51	2	- 32	2	42.0	144.5	71.4	120.0	

C-23611

(SAE J516/J518)

STRAIGHT SAE FLANGE 6000PSI
CODE 62

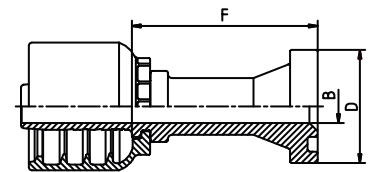

PART. REF. C	HOSE BORE			FLANGE	DIMENSIONS				
	DN	INCH	SIZE	CODE 62	B	F	D		
C-23611 - 08 - 08	12	1/2	- 08	1/2	9.5	52.1	31.8		
C-23611 - 08 - 12	12	1/2	- 08	3/4	9.5	68.4	41.3		
C-23611 - 10 - 08	16	5/8	- 10	1/2	9.3	52.0	31.8		
C-23611 - 10 - 12	16	5/8	- 10	3/4	12.0	70.2	41.3		
C-23611 - 12 - 12	19	3/4	- 12	3/4	14.0	52.5	41.3		
C-23611 - 12 - 16	19	3/4	- 12	5/8	14.0	57.5	47.6		
C-23611 - 16 - 12	25	1	- 16	3/4	19.0	54.2	41.3		
C-23611 - 16 - 16	25	1	- 16	5/8	19.0	59.2	47.6		
C-23611 - 16 - 20	25	1	- 16	1.1/4	19.0	67.2	54.0		
C-23611 - 20 - 16	31	1.1/4	- 16	5/8	25.0	61.7	47.6		
C-23611 - 20 - 20	31	1.1/4	- 16	1.1/4	25.0	69.7	54.0		
C-23611 - 20 - 24	31	1.1/4	- 16	1.1/2	25.0	78.7	63.5		
C-23611 - 24 - 20	38	1.1/2	- 16	1.1/4	31.0	74.5	54.0		
C-23611 - 24 - 24	38	1.1/2	- 16	1.1/2	31.0	83.5	63.5		
C-23611 - 24 - 32	38	1.1/2	- 16	2	31.0	93.5	79.4		
C-23611 - 32 - 24	51	2	- 32	1.1/2	42.0	85.7	63.5		
C-23611 - 32 - 32	51	2	- 32	2	42.0	95.7	79.4		

C-23621

(SAE J516/J518)

22.5° SAE FLANGE 6000PSI
CODE 62

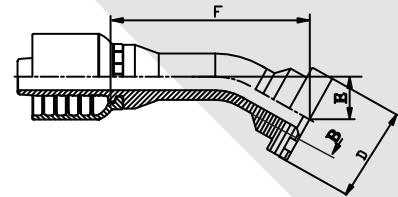

PART. REF. C	HOSE BORE			FLANGE	DIMENSIONS				
	DN	INCH	SIZE	CODE 62	B	F	D	E	
C-23621 - 12 - 12	19	3/4	- 12	3/4	14.0	63.6	41.3	11.0	
C-23621 - 16 - 16	25	1	- 16	1	19.0	76.3	47.6	14.0	
C-23621 - 20 - 20	31	1.1/4	- 20	1.1/4	25.0	89.3	54.0	15.0	
C-23621 - 24 - 24	38	1.1/2	- 24	1.1/2	31.0	109.5	63.5	18.0	
C-23621 - 32 - 32	51	2	- 32	2	42.0	131.1	79.4	22.1	

C-23631

(SAE J516/J518)

30° SAE FLANGE 6000PSI
CODE 62

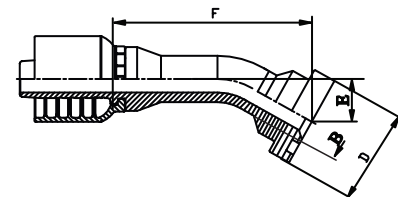

PART. REF. C	HOSE BORE			FLANGE	DIMENSIONS				
	DN	INCH	SIZE	FL62	B	F	D	E	
C-23631 - 12 - 12	19	3/4	- 12	3/4	14.0	67.1	41.3	16.0	
C-23631 - 16 - 16	25	1	- 16	1	*	*	*	*	
C-23631 - 20 - 20	31	1.1/4	- 20	1.1/4	25.0	94.9	54.0	22.0	
C-23631 - 24 - 24	38	1.1/2	- 24	1.1/2	31.0	122.3	63.5	30.0	
C-23691 - 32 - 32	51	2	- 32	2	42.0	138.9	79.4	32.0	

C-23641

(SAE J516/J518)

45° SAE FLANGE 6000PSI
CODE 62

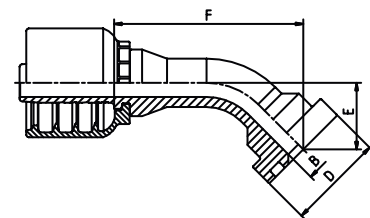

PART. REF. C	HOSE BORE			FLANGE	DIMENSIONS				
	DN	INCH	SIZE	FL62	B	F	D	E	
C-23641 - 08 - 08	12	1/2	- 08	1/2	9.5	62.0	31.8	22.0	
C-23641 - 08 - 12	12	1/2	- 08	3/4	9.5	59.5	41.3	25.0	
C-23641 - 10 - 12	16	5/8	- 10	3/4	12.0	65.0	41.3	26.0	
C-23641 - 12 - 12	19	3/4	- 12	3/4	14.0	70.2	41.3	26.0	
C-23641 - 12 - 16	19	3/4	- 12	1	14.0	76.2	47.6	32.0	
C-23641 - 16 - 12	25	1	- 16	3/4	19.0	81.6	41.3	30.0	
C-23641 - 16 - 16	25	1	- 16	1	19.0	83.6	47.6	32.0	
C-23641 - 16 - 20	25	1	- 16	1.1/4	19.0	89.6	54.0	38.0	
C-23641 - 20 - 16	31	1.1/4	- 20	1	25.0	99.5	47.6	35.0	
C-23641 - 20 - 20	31	1.1/4	- 20	1.1/4	25.0	102.5	54.0	38.0	
C-23641 - 20 - 24	31	1.1/4	- 20	1.1/2	25.0	108.5	63.5	44.0	
C-23641 - 24 - 20	38	1.1/2	- 24	1.1/4	31.0	119.6	54.0	40.0	
C-23641 - 24 - 24	38	1.1/2	- 24	1.1/2	31.0	123.6	63.5	44.0	
C-23641 - 24 - 32	38	1.1/2	- 24	2	31.0	135.6	79.4	56.0	
C-23641 - 32 - 32	51	2	- 32	2	42.0	151.7	79.4	56.0	

C-23661

(SAE J516/J518)
60° SAE FLANGE 6000PSI
CODE 62

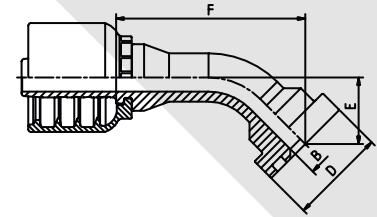

PART. REF. C	HOSE BORE			FLANGE	DIMENSIONS				
	DN	INCH	SIZE	CODE 62	B	F	D	E	
C-23661 - 12 - 12	19	3/4	- 12	3/4	14.0	70.9	41.3	37.0	
C-23661 - 12 - 16	19	3/4	- 12	1	14.0	75.0	47.6	44.0	
C-23661 - 16 - 16	25	1	- 16	1	19.0	83.9	47.6	44.0	
C-23661 - 16 - 20	25	1	- 16	1	19.0	90.2	54.0	55.0	
C-23661 - 20 - 20	31	1.1/4	- 20	1.1/4	25.0	104.8	54.0	55.0	
C-23661 - 20 - 24	31	1.1/4	- 20	1.1/2	25.0	110.0	63.5	64.0	
C-23661 - 24 - 24	31	1.1/2	- 24	1.1/4	31.0	126.8	63.5	64.0	
C-23661 - 32 - 32	51	2	- 32	2	42.0	157.2	79.4	83.0	

C-23671

(SAE J516/J518)
67.5° SAE FLANGE 6000PSI
CODE 62

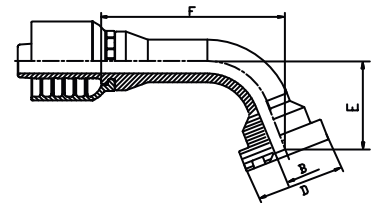

PART. REF. C	HOSE BORE			FLANGE	DIMENSIONS				
	DN	INCH	SIZE	CODE 62	B	F	D	E	
C-23671 - 12 - 12	19	3/4	- 12	3/4	14.0	70.0	41.3	42.0	
C-23671 - 16 - 16	25	1	- 16	1	19.0	83.4	47.6	51.0	
C-23671 - 20 - 20	31	1.1/4	- 20	1.1/4	25.0	104.3	54.0	64.0	
C-23671 - 24 - 24	38	1.1/2	- 24	1.1/2	31.0	126.3	63.5	74.0	
C-23671 - 32 - 32	51	2	- 32	2	42.0	157.0	79.4	97.0	

C-23691

(SAE J516/J518)
90° SAE FLANGE 6000PSI
CODE 62

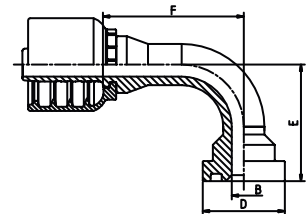

PART. REF. C	HOSE BORE			FLANGE	DIMENSIONS				
	DN	INCH	SIZE	CODE 62	B	F	D	E	
C-23691 - 08 - 08	12	1/2	- 08	1/2	9.3	54.5	31.8	45.0	
C-23691 - 08 - 12	12	1/2	- 08	3/4	15.0	54.5	41.3	53.0	
C-23691 - 10 - 12	16	5/8	- 10	3/4	12.0	56.0	41.3	58.0	
C-23691 - 12 - 12	19	3/4	- 12	3/4	14.0	63.5	47.6	70.0	
C-23691 - 12 - 16	19	3/4	- 12	1	19.0	76.2	47.6	70.0	
C-23691 - 16 - 12	25	1	- 16	3/4	19.0	76.2	41.3	68.0	
C-23691 - 16 - 16	25	1	- 16	1	19.0	76.2	47.6	70.0	
C-23691 - 16 - 20	25	1	- 16	1.1/4	19.0	76.2	54.0	80.0	
C-23691 - 20 - 16	31	1.1/4	- 20	1	25.0	95.2	47.6	82.0	
C-23691 - 20 - 20	31	1.1/4	- 20	1.1/4	25.0	95.2	54.0	90.0	
C-23691 - 20 - 24	31	1.1/4	- 20	1.1/2	25.0	95.2	63.5	104.0	
C-23691 - 24 - 20	38	1.1/2	- 24	1.1/4	31.0	116.5	54.0	95.0	
C-23691 - 24 - 24	38	1.1/2	- 24	1.1/4	31.0	116.5	63.5	104.0	
C-23691 - 24 - 32	38	1.1/2	- 24	2	31.0	116.5	79.4	110.0	
C-23691 - 32 - 32	51	2	- 32	2	42.0	144.5	79.4	138.0	

C-23911

STRAIGHT "SUPERCAT" STYLE FLANGE
CODE SUPERCAT

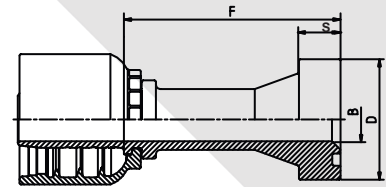

PART. REF. C	HOSE BORE			FLANGE CODE CAT	DIMENSIONS				
	DN	INCH	SIZE		B	F	D	S	
C-23911 - 12 - 12	19	3/4	- 12	3/4	14.0	58.0	41.3	14.3	
C-23911 - 12 - 16	19	3/4	- 12	1	14.0	62.3	47.6	14.3	
C-23911 - 16 - 16	25	1	- 16	1	19.0	64.0	47.6	14.3	
C-23911 - 16 - 20	25	1	- 16	1.1/4	19.0	71.2	54.0	14.3	
C-23911 - 20 - 20	31	1.1/4	- 20	1.1/4	25.0	73.7	54.0	14.3	
C-23911 - 20 - 24	31	1.1/4	- 20	1.1/2	25.0	80.4	63.5	14.3	
C-23911 - 24 - 24	38	1.1/2	- 24	1.1/2	31.0	85.2	63.5	14.3	
C-23911 - 24 - 32	38	1.1/2	- 24	2	31.0	95.3	79.4	14.3	
C-23911 - 32 - 24	51	2	- 32	1.1/2	42.0	87.4	63.5	14.3	
C-23911 - 32 - 32	51	2	- 32	2	42.0	97.4	79.4	14.3	

C-23921

22.5° "SUPERCAT" STYLE FLANGE
CODE SUPERCAT

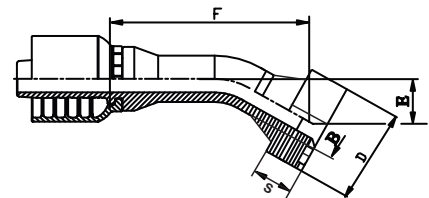

PART. REF. C	HOSE BORE			FLANGE CODE CAT	DIMENSIONS				
	DN	INCH	SIZE		B	F	D	E	S
C-23921 - 12 - 12	19	3/4	- 12	3/4	14.0	68.5	41.3	13.0	14.3
C-23921 - 12 - 16	19	3/4	- 12	1	14.0	75.7	47.6	16.0	14.3
C-23921 - 16 - 16	25	1	- 16	1	19.0	80.7	47.6	16.0	14.3
C-23921 - 16 - 20	25	1	- 16	1.1/4	19.0	82.4	54.0	16.5	14.3
C-23921 - 20 - 20	31	1.1/4	- 20	1.1/4	25.0	93.0	54.0	17.0	14.3
C-23921 - 20 - 24	31	1.1/4	- 20	1.1/2	25.0	97.8	63.5	18.5	14.3
C-23921 - 24 - 24	38	1.1/2	- 24	1.1/2	31.0	110.7	63.5	18.5	14.3

C-23931

30° "SUPERCAT" STYLE FLANGE
CODE SUPERCAT

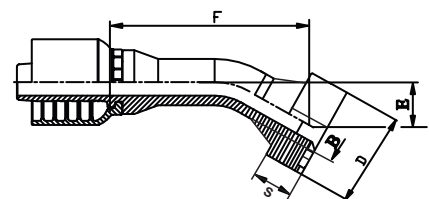

PART. REF. C	HOSE BORE			FLANGE CODE CAT	DIMENSIONS				
	DN	INCH	SIZE		B	F	D	E	S
C-23931 - 12 - 12	19	3/4	- 12	3/4	14.0	72.3	41.3	19.0	14.3
C-23931 - 12 - 16	19	3/4	- 12	1	14.0	76.6	47.6	21.5	14.3
C-23931 - 16 - 16	25	1	- 16	1	19.0	82.7	47.6	21.5	14.3
C-23931 - 16 - 20	25	1	- 16	1.1/4	19.0	87.0	54.0	24.0	14.3
C-23931 - 20 - 20	31	1.1/4	- 20	1.1/4	25.0	98.3	54.0	24.0	14.3
C-23931 - 20 - 24	31	1.1/4	- 20	1.1/2	25.0	110.5	63.5	31.0	14.3
C-23931 - 24 - 32	38	1.1/2	- 24	2	31.0	127.5	79.4	33.0	14.3
C-23931 - 32 - 32	51	2	- 32	2	42.0	140.7	79.4	33.0	14.3

C-23941

45° "SUPERCAT" STYLE FLANGE
CODE SUPERCAT

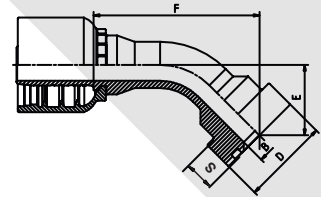

PART. REF. C	HOSE BORE			FLANGE CODE CAT	DIMENSIONS					
	DN	INCH	SIZE		B	F	D	E	S	W
C-23941 - 12 - 12	19	3/4	- 12	3/4	14.0	74.2	41.3	30.0	14.3	
C-23941 - 12 - 16	19	3/4	- 12	1	14.0	79.7	47.6	35.5	14.3	
C-23941 - 16 - 16	25	1	- 16	1	19.0	87.1	47.6	35.5	14.3	
C-23941 - 16 - 20	25	1	- 16	1.1/4	19.0	92.6	54.0	41.0	14.3	
C-23941 - 20 - 20	31	1.1/4	- 20	1.1/4	25.0	105.4	54.0	41.0	14.3	
C-23941 - 20 - 24	31	1.1/4	- 20	1.1/2	25.0	109.5	63.5	45.0	14.3	
C-23941 - 24 - 24	38	1.1/2	- 24	1.1/2	31.0	124.6	63.5	45.0	14.3	
C-23941 - 24 - 32	38	1.1/2	- 24	2	31.0	136.6	79.4	57.0	14.3	
C-23941 - 32 - 32	51	2	- 32	2	42.0	152.7	79.4	57.0	14.3	

C-23961

60° "SUPERCAT" STYLE FLANGE
CODE SUPERCAT

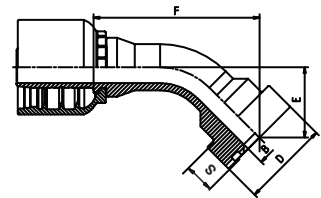

PART. REF. C	HOSE BORE			FLANGE CODE CAT	DIMENSIONS					
	DN	INCH	SIZE		B	F	D	E	S	W
C-23961 - 12 - 12	19	3/4	- 12	3/4	14.0	73.8	41.3	42.0	14.3	
C-23961 - 12 - 16	19	3/4	- 12	1	14.0	77.3	47.6	48.0	14.3	
C-23961 - 16 - 16	25	1	- 16	1	19.0	86.2	47.6	48.0	14.3	
C-23961 - 16 - 20	25	1	- 16	1.1/4	19.0	92.2	54.0	58.0	14.3	
C-23961 - 20 - 20	31	1.1/4	- 20	1.1/4	25.0	106.8	54.0	58.5	14.3	
C-23961 - 20 - 24	31	1.1/4	- 20	1.1/2	25.0	110.8	63.5	65.5	14.3	
C-23961 - 24 - 24	38	1.1/2	- 24	1.1/2	31.0	127.7	63.5	65.5	14.3	
C-23961 - 32 - 32	38	1.1/2	- 24	2	42.0	158.1	79.4	84.5	14.3	

C-23971

67.5° "SUPERCAT" STYLE FLANGE
CODE SUPERCAT

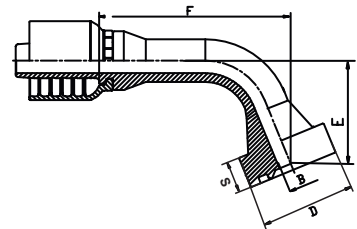

PART. REF. C	HOSE BORE			FLANGE CODE CAT	DIMENSIONS					
	DN	INCH	SIZE		B	F	D	E	S	W
C-23971 - 12 - 12	19	3/4	- 12	3/4	14.0	72.0	41.3	47.0	14.3	
C-23971 - 12 - 16	19	3/4	- 12	1	14.0	75.5	47.6	55.5	14.3	
C-23971 - 16 - 16	25	1	- 16	1	19.0	85.3	47.6	55.5	14.3	
C-23971 - 16 - 20	25	1	- 16	1.1/4	19.0	90.2	54.0	67.5	14.3	
C-23971 - 20 - 20	31	1.1/4	- 20	1.1/4	25.0	105.7	54.0	67.5	14.3	
C-23971 - 20 - 24	31	1.1/4	- 20	1.1/2	25.0	109.1	63.5	75.5	14.3	
C-23971 - 24 - 24	38	1.1/2	- 24	1.1/2	31.0	126.9	63.5	75.5	14.3	
C-23971 - 32 - 32	51	2	- 32	2	42.0	157.6	79.4	98.5	14.3	

C-23991

90° "SUPERCAT" STYLE FLANGE
CODE SUPERCAT

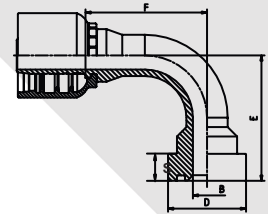

PART. REF. C	HOSE BORE			FLANGE	DIMENSIONS				
	DN	INCH	SIZE	CODE CAT	B	F	D	E	S
C-23991 - 12 - 12	19	3/4	- 12	3/4	14.0	63.5	41.3	63.5	14.3
C-23991 - 12 - 16	19	3/4	- 12	1	14.0	63.5	47.6	75.0	14.3
C-23991 - 16 - 16	25	1	- 16	1	19.0	76.2	47.6	75.0	14.3
C-23991 - 16 - 20	25	1	- 16	1.1/4	19.0	76.2	54.0	84.0	14.3
C-23991 - 20 - 20	31	1.1/4	- 20	1.1/4	25.0	95.2	54.0	94.0	14.3
C-23991 - 20 - 24	31	1.1/4	- 20	1.1/2	25.0	104.0	63.5	105.5	14.3
C-23991 - 24 - 24	38	1.1/2	- 24	1.1/2	31.0	116.5	63.5	105.5	14.3
C-23991 - 24 - 32	38	1.1/2	- 24	2	31.0	116.5	79.4	120.0	14.3
C-23991 - 32 - 32	51	2	- 32	2	42.0	144.5	79.4	139.5	14.3

C-24111

STRAIGHT "KOMATSU" STYLE FLANGE
CODE KOMATSU

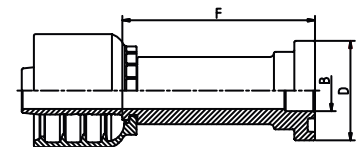

PART. REF. C	HOSE BORE			FLANGE	DIMENSIONS				
	DN	INCH	SIZE	KOMATSU	B	F	D		
C-24111 - 08 - 10	12	1/2	- 08	5/8	14.0	66.0	34.2		
C-24111 - 10 - 10	16	5/8	- 10	5/8	12.0	65.7	34.2		

C-24141

45° "KOMATSU" STYLE FLANGE
CODE KOMATSU

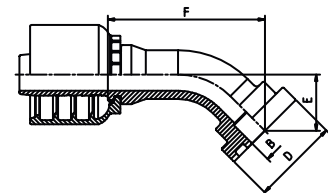

PART. REF. C	HOSE BORE			FLANGE	DIMENSIONS				
	DN	INCH	SIZE	KOMATSU	B	F	D	E	
C-24141 - 08 - 10	12	1/2	- 10	5/8	*	*	*	*	
C-24141 - 10 - 10	16	5/8	- 10	5/8	12.0	61.0	34.2	22.0	

C-24191

90° "KOMATSU" STYLE FLANGE
CODE KOMATSU

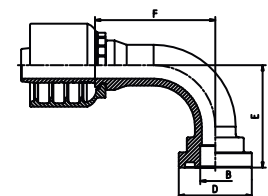

PART. REF. C	HOSE BORE			FLANGE	DIMENSIONS				
	DN	INCH	SIZE	KOMATSU	B	F	D	E	
C-24191 - 08 - 10	12	1/2	- 08	5/8	*	*	*	*	
C-24191 - 10 - 10	16	5/8	- 10	5/8	14.0	56.0	34.0	47.5	

C-10510

BSP MALE PARALLEL 60° CONE SEAT

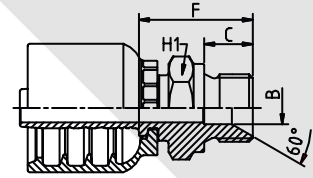

PART. REF. C	HOSE BORE			THREAD	DIMENSIONS				
	DN	INCH	SIZE	BSP	B	F	C		H1
C-10510 - 06 - 04	10	3/8	- 06	1/4 - 19	7.0	26.0	11.0		19
C-10510 - 06 - 06	10	3/8	- 06	3/8 - 19	7.0	28.1	13.5		22
C-10510 - 06 - 08	10	3/8	- 06	1/2 - 14	7.0	30.6	14.0		27
C-10510 - 08 - 06	12	1/2	- 08	3/8 - 19	9.5	28.1	12.0		22
C-10510 - 08 - 08	12	1/2	- 08	1/2 - 14	9.5	31.1	14.0		27
C-10510 - 08 - 10	12	1/2	- 08	5/8 - 14	9.5	33.1	16.0		30
C-10510 - 08 - 12	12	1/2	- 08	3/4 - 14	9.5	34.1	16.0		32
C-10510 - 10 - 10	16	5/8	- 10	5/8 - 14	12.0	33.1	16.0		30
C-10510 - 10 - 12	16	5/8	- 10	3/4 - 14	12.0	34.1	16.0		32
C-10510 - 12 - 12	19	3/4	- 12	3/4 - 14	15.0	41.0	18.5		32
C-10510 - 12 - 16	19	3/4	- 12	1 - 11	15.0	39.5	19.0		41
C-10510 - 16 - 16	25	1	- 16	1 - 11	19.0	47.2	20.5		41
C-10510 - 16 - 20	25	1	- 16	1.1/4 - 11	28.6	50.2	20.0		50
C-10510 - 20 - 20	31	1.1/4	- 20	1.1/4 - 11	25.0	52.7	20.0		50
C-10510 - 24 - 24	38	1.1/2	- 24	1.1/4 - 11	31.0	59.5	22.0		55
C-10510 - 32 - 32	51	2	- 32	2 - 11	42.0	71.2	25.5		70

C-10610

BSP MALE FLAT SEAT

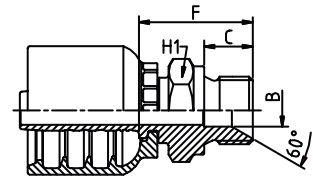

PART. REF. C	HOSE BORE			THREAD	DIMENSIONS				
	DN	INCH	SIZE	BSP	B	F	C		H1
C-10610 - 06 - 06	10	3/8	- 06	3/8 - 19	9.5	28.1	12.0		22
C-10610 - 06 - 08	10	3/8	- 06	1/2 - 14	13.0	30.6	14.0		27
C-10610 - 08 - 08	12	1/2	- 08	1/2 - 14	13.0	31.1	14.0		27

C-10710

BSP MALE TAPERED

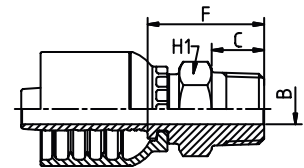

PART. REF. C	HOSE BORE			THREAD	DIMENSIONS				
	DN	INCH	SIZE	BSP	B	F	C		H1
C-10710 - 06 - 06	10	3/8	- 06	3/8 - 19	7.0	27.1	15.0		19
C-10710 - 06 - 08	10	3/8	- 06	1/2 - 14	10.0	30.6	15.0		22
C-10710 - 08 - 08	12	1/2	- 08	1/2 - 14	10.0	31.1	15.0		22
C-10710 - 10 - 12	16	5/8	- 10	3/4 - 14	17.0	37.0	17.0		27

C-20612/13

**(SAE J516/J514)[THRUST WIRE/SLIP-ON]
BSP FEMALE FLAT SEAT**

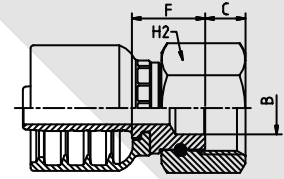

PART. REF. C	HOSE BORE			THREAD	DIMENSIONS				
	DN	INCH	SIZE	BSP	B	F	C		H2
C-20613 - 06 - 06	10	3/8	- 06	3/8 - 19	7.0	18.0	9.0		22
C-20613 - 06 - 08	10	3/8	- 06	1/2 - 14	7.0	19.5	11.0		27
C-20613 - 08 - 08	12	1/2	- 08	1/2 - 14	9.3	17.9	9.8		27
C-20612 - 08 - 12	12	1/2	- 08	3/4 - 14	15.0	20.9	11.5		32
C-20612 - 10 - 10	16	5/8	- 10	5/8 - 14	*	*	*		*
C-20612 - 10 - 12	16	5/8	- 10	3/4 - 14	15.0	20.7	11.5		32

C-20712/C-20812

**[THRUST WIRE]
BSP O-RING FEMALE 60° CONE SEAT
*Double nut on C-20712 Series**

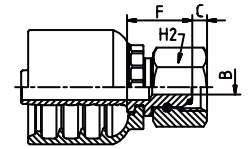
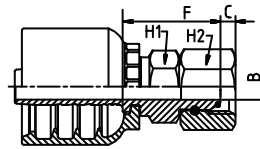

PART. REF. C	HOSE BORE			THREAD	DIMENSIONS				
	DN	INCH	SIZE	BSP	B	F	C	H1	H2
C-20812 - 06 - 04	10	3/8	- 06	1/4 - 19	7.0	18.5	5.0		19
C-20812 - 06 - 06	10	3/8	- 06	3/8 - 19	7.0	20.4	5.5		22
C-20812 - 06 - 08	10	3/8	- 06	1/2 - 14	7.0	23.8	6.5		27
C-20812 - 08 - 06	12	1/2	- 08	3/8 - 19	9.5	21.0	5.5		22
C-20812 - 08 - 08	12	1/2	- 08	1/2 - 14	9.5	22.2	6.5		27
C-20812 - 08 - 10	12	1/2	- 08	5/8 - 14	9.5	21.9	9.5		30
C-20812 - 08 - 12	12	1/2	- 08	3/4 - 14	9.5	23.4	9.0		32
C-20812 - 10 - 10	16	5/8	- 10	5/8 - 14	12.0	22.1	9.5		30
C-20812 - 10 - 12	16	5/8	- 10	3/4 - 14	12.0	23.2	9.0		32
C-20712 - 12 - 12	19	3/4	- 12	3/4 - 14	15.0	39.5	9.0	32	32
C-20712 - 12 - 16	19	3/4	- 12	1 - 11	20.0	43.0	10.0	38	38
C-20712 - 16 - 12	25	1	- 16	3/4 - 14	15.0	41.2	9.0	32	32
C-20712 - 16 - 16	25	1	- 16	1 - 11	19.0	44.7	10.0	38	38
C-20712 - 16 - 20	25	1	- 16	1.1/4 - 14	25.0	50.2	10.5	50	50
C-20712 - 20 - 16	31	1.1/4	- 20	1 - 11	20.0	47.2	10.0	41	38
C-20712 - 20 - 20	31	1.1/4	- 20	1.1/4 - 14	25.0	52.7	10.5	50	50
C-20712 - 20 - 24	31	1.1/4	- 20	1.1/2 - 14	30.5	54.2	12.5	55	55
C-20712 - 24 - 20	38	1.1/2	- 24	1.1/4 - 14	25.0	57.5	10.5	50	50
C-20712 - 24 - 24	38	1.1/2	- 24	1.1/2 - 14	31.0	59.0	12.5	55	55
C-20712 - 32 - 32	51	2	- 32	2 - 11	42.0	68.7	16.0	70	70

C-20742/C-20842

[THRUST WIRE]

45° BSP O’RING FEMALE 60° CONE SEAT

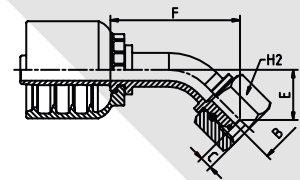

PART. REF. C	HOSE BORE			THREAD	DIMENSIONS				
	DN	INCH	SIZE	BSP	B	F	C	E	H2
C-20842 - 06 - 04	10	3/8	- 06	1/4 - 19	*	*	*	*	*
C-20842 - 06 - 06	10	3/8	- 06	3/8 - 19	7.0	44.5	5.5	18.5	22
C-20842 - 06 - 08	10	3/8	- 06	1/2 - 14	7.0	42.5	6.5	16.0	27
C-20842 - 08 - 08	12	1/2	- 08	1/2 - 14	9.5	52.0	6.5	20.5	27
C-20842 - 08 - 10	12	1/2	- 08	5/8 - 14	12.1	54.5	10.2	22.5	28
C-20842 - 08 - 12	12	1/2	- 08	3/4 - 14	15.0	57.0	9.0	25.0	32
C-20842 - 10 - 10	16	5/8	- 10	5/8 - 14	12.0	63.5	9.5	27.5	30
C-20842 - 10 - 12	16	5/8	- 10	3/4 - 14	15.0	64.0	9.0	27.0	32
C-20742 - 12 - 12	19	3/4	- 12	3/4 - 14	15.0	75.2	9.0	29.0	32
C-20742 - 12 - 16	19	3/4	- 12	1 - 11	15.0	78.2	10.0	32.0	38
C-20742 - 16 - 16	25	1	- 16	1 - 11	19.0	86.6	10.0	35.0	38
C-20742 - 16 - 20	25	1	- 16	1.1/4 - 11	19.0	90.6	10.5	39.0	50
C-20742 - 20 - 20	31	1.1/4	- 20	1.1/4 - 11	25.0	104.5	10.5	40.0	50
C-20742 - 20 - 24	31	1.1/4	- 20	1.1/2 - 11	25.0	118.5	12.5	54.0	55
C-20742 - 24 - 24	38	1.1/2	- 24	1.1/2 - 11	31.0	129.6	12.5	50.0	50
C-20742 - 32 - 32	51	2	- 32	2 - 11	42.0	165.7	16.0	70.0	70

C-20792/C-20892

[THRUST WIRE]

90° BSP O’RING FEMALE 60° CONE SEAT

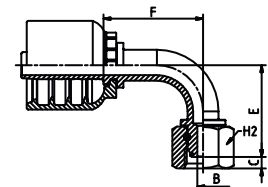

PART. REF. C	HOSE BORE			THREAD	DIMENSIONS				
	DN	INCH	SIZE	BSP	B	F	C	E	H2
C-20892 - 06 - 04	10	3/8	- 06	1/4 - 19	7.0	35.5	5.0	33.0	19
C-20892 - 06 - 06	10	3/8	- 06	3/8 - 19	7.0	35.5	5.5	36.0	22
C-20892 - 06 - 08	10	3/8	- 06	1/2 - 14	7.0	36.5	6.5	32.0	27
C-20892 - 08 - 06	12	1/2	- 08	3/8 - 19	7.0	45.0	6.0	41.0	22
C-20892 - 08 - 08	12	1/2	- 08	1/2 - 14	9.5	44.5	6.5	42.0	27
C-20892 - 08 - 10	12	1/2	- 08	5/8 - 14	12.1	44.0	10.2	44.0	28
C-20892 - 08 - 12	12	1/2	- 08	3/4 - 14	9.5	44.0	9.0	45.5	32
C-20892 - 10 - 10	16	5/8	- 10	5/8 - 14	12.0	53.0	9.5	55.0	30
C-20892 - 10 - 12	16	5/8	- 10	3/4 - 14	15.0	53.5	9.0	55.0	32
C-20792 - 12 - 12	19	3/4	- 12	3/4 - 14	15.0	65.5	9.0	58.0	32
C-20792 - 12 - 16	19	3/4	- 12	1 - 11	15.0	65.5	10.0	62.0	38
C-20792 - 16 - 16	25	1	- 16	1 - 11	19.0	76.2	10.0	70.0	38
C-20792 - 16 - 20	25	1	- 16	1.1/4 - 11	19.0	76.2	10.5	76.0	50
C-20792 - 20 - 20	31	1.1/4	- 20	1.1/4 - 11	25.0	95.2	10.5	85.0	50
C-20792 - 24 - 24	38	1.1/2	- 24	1.1/2 - 11	31.0	116.5	12.5	100.0	55
C-20792 - 32 - 32	51	2	- 32	2 - 11	42.0	144.5	16.0	140.0	70

C-20882

[THRUST WIRE]

90° BSP O-RING FEMALE COMPACT ELBOW 60° CONE SEAT

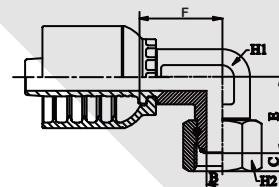

PART. REF. C	HOSE BORE			THREAD	DIMENSIONS					
	DN	INCH	SIZE	BSP	B	F	C	E	H1	H2
C-20882 - 06 - 06	10	3/8	- 06	3/8 - 19	7.0	23.1	5.5	27.5	19	22
C-20882 - 08 - 08	12	1/2	- 08	1/2 - 14	9.5	23.0	6.5	31.1	22	27
C-20882 - 10 - 10	16	5/8	- 10	5/8 - 14	12.0	24.6	9.5	32.5	24	30
C-20882 - 12 - 12	19	3/4	- 12	3/4 - 14	*	*	*	*	*	*
C-20882 - 16 - 16	25	1	- 16	1 - 11	*	*	*	*	*	*

C-20310

BSP BANJO

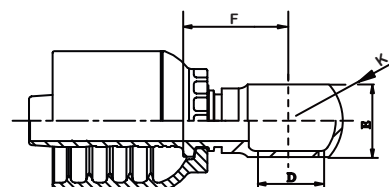

PART. REF. C	HOSE BORE			BOLT	DIMENSIONS					
	DN	INCH	SIZE	D	B	F	D	E	K	
C-20310 - 06 - 04	10	3/8	- 06	1/4 - 19	*	*	*	*	*	
C-20310 - 06 - 06	10	3/8	- 06	3/8 - 19	7.0	24.1	16.7	18.0	28.0	
C-20310 - 06 - 08	10	3/8	- 06	1/2 - 14	7.0	27.1	21.2	22.0	35.0	
C-20310 - 08 - 06	12	1/2	- 08	1/2 - 14	*	*	*	*	*	
C-20310 - 08 - 08	12	1/2	- 08	1/4 - 14	9.5	27.5	21.2	22.0	35.0	
C-20310 - 10 - 10	16	5/8	- 10	5/8 - 14	12.0	28.2	23.0	23.5	38.0	

C-11110

METRIC MALE 24° CONE SEAT
LIGHT TYPE

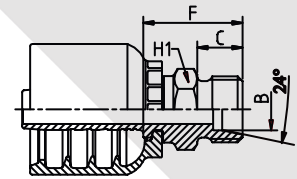

PART. REF. C	HOSE BORE			THREAD	TUBE	DIMENSIONS				
	DN	INCH	SIZE	LT. METRIC	MM	B	F	C	H1	
C-11110 - 06 - 16	10	3/8	- 16	M16X1.5	10	7.0	24.1	11.0	17	
C-11110 - 06 - 18	10	3/8	- 16	M18X1.5	12	7.0	24.6	11.0	19	
C-11110 - 06 - 22	10	3/8	- 16	M22X1.5	15	7.0	25.6	12.0	22	
C-11110 - 08 - 18	12	1/2	- 08	M18X1.5	12	9.5	25.6	12.0	22	
C-11110 - 08 - 22	12	1/2	- 08	M22X1.5	15	12.0	27.0	12.0	22	
C-11110 - 08 - 26	12	1/2	- 08	M26X1.5	18	9.5	26.4	12.0	27	
C-11110 - 10 - 22	16	5/8	- 10	M22X1.5	15	12.0	27.0	12.0	22	
C-11110 - 10 - 26	16	5/8	- 10	M26X1.5	18	12.0	26.7	12.0	27	
C-11110 - 10 - 30	16	5/8	- 10	M30X2.0	22	15.0	28.5	14.0	30	

C-11210

METRIC MALE 24° CONE SEAT
STRONG TYPE HEAVY DUTY

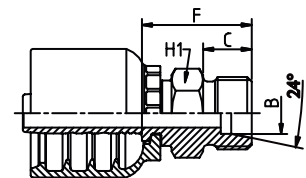

PART. REF. C	HOSE BORE			THREAD	TUBE	DIMENSIONS				
	DN	INCH	SIZE	HT. METRIC	MM	B	F	C	H1	
C-11210 - 06 - 18	10	3/8	- 06	M18X1.5	10	7.0	27.1	12.0	19	
C-11210 - 06 - 20	10	3/8	- 06	M20X1.5	12	7.0	29.1	12.0	22	
C-11210 - 06 - 22	10	3/8	- 06	M22X1.5	14	7.0	31.1	14.0	22	
C-11210 - 06 - 24	10	3/8	- 06	M24X1.5	16	*	*	*	*	
C-11210 - 08 - 22	12	1/2	- 08	M22X1.5	14	9.3	31.5	14.0	22	
C-11210 - 08 - 24	12	1/2	- 08	M24X1.5	16	9.5	31.6	14.0	24	
C-11210 - 10 - 30	16	5/8	- 10	M30X2.0	20	12.0	35.7	16.0	30	
C-11210 - 12 - 30	19	3/4	- 12	M30X2.0	20	15.0	37.5	16.0	32	
C-11210 - 12 - 36	19	3/4	- 12	M36X2.0	25	20.0	41.5	18.0	41	
C-11210 - 16 - 36	25	1	- 16	M36X2.0	25	19.0	43.7	18.0	41	
C-11210 - 16 - 42	25	1	- 16	M42X2.0	30	19.0	50.7	20.0	46	
C-11210 - 20 - 52	31	1.1/4	- 20	M52X2.0	38	25.0	61.7	22.0	55	
C-11210 - 24 - 52	38	1.1/2	- 24	M52X2.0	38	31.0	66.5	22.0	55	

C-11710

FRENCH METRIC MALE 24° CONE SEAT
MILLIMETRIC TYPE

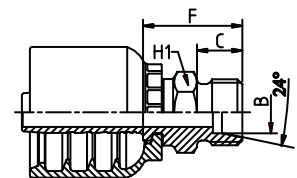

PART. REF. C	HOSE BORE			THREAD	TUBE	DIMENSIONS				
	DN	INCH	SIZE	FR. METRIC	MM	B	F	C	H1	
C-11710 - 10 - 2718	16	5/8	- 10	M27X1.5	18	12.5	28.7	14.0	28	
C-11710 - 10 - 2720	16	5/8	- 10	M27X1.5	20	12.5	28.7	14.0	28	

C-11810

FRENCH METRIC MALE 24° CONE SEAT
GAZ TYPE

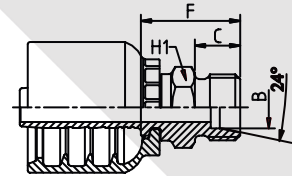

PART. REF. C	HOSE BORE			THREAD	TUBE	DIMENSIONS				
	DN	INCH	SIZE	FR. METRIC	MM	B	F	C		H1
C-11810 - 06 - 20	10	3/8	- 06	M20X1.5	13.25	8.0	27.0	12.0		22
C-11810 - 06 - 24	10	3/8	- 06	M24X1.5	16.75	12.0	28.1	12.0		24
C-11810 - 08 - 24	12	1/2	- 08	M24X1.5	16.75	12.0	28.4	12.0		24
C-11810 - 10 - 30	16	5/8	- 10	M30X1.5	21.25	15.0	31.7	14.0		30

C-11813

FRENCH METRIC MALE 24° CONE SEAT
"KOBELCO" TYPE

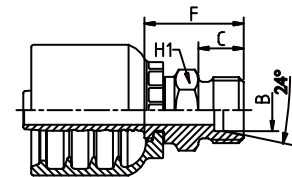

PART. REF. C	HOSE BORE			THREAD	TUBE	DIMENSIONS				
	DN	INCH	SIZE	FR. METRIC	MM	B	F	C		H1
C-11813 - 10 - 30	16	5/8	- 10	M30X1.5	22	12.0	29.5	14.0		30

C-20910

(DIN7642)
METRIC BANJO

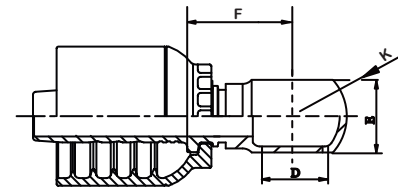

PART. REF. C	HOSE BORE			BOLT	TUBE	DIMENSIONS				
	DN	INCH	SIZE	D	B	F	D	E	K	
C-20910 - 06 - 14	10	3/8	- 06	M14X1.5	7.0	24.1	14.0	14.0	24.0	
C-20910 - 06 - 16	10	3/8	- 06	M16X1.5	7.0	24.1	16.0	18.0	28.0	
C-20910 - 06 - 18	10	3/8	- 06	M18X1.5	7.0	27.1	18.0	20.0	32.0	
C-20910 - 08 - 18	12	1/2	- 08	M18X1.5	9.5	27.5	18.0	20.0	32.0	
C-20910 - 08 - 22	12	1/2	- 08	M22X1.5	9.5	27.5	22.0	22.0	35.0	
C-20910 - 10 - 22	16	5/8	- 10	M22X1.5	12.0	28.2	22.0	23.5	38.0	

C-21512

(DIN20066/3865)[THRUST WIRE/SLIP-ON]
 STRAIGHT O’RING METRIC FEMALE 24° CONE
 LIGHT TYPE

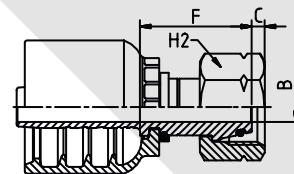

PART. REF. C	HOSE BORE			THREAD	TUBE	DIMENSIONS				
	DN	INCH	SIZE	LT. METRIC	MM	B	F	C		H2
C-21512 - 06 - 16	10	3/8	- 06	M16X1.5	10	5.5	23.1	1.5		19
C-21512 - 06 - 18	10	3/8	- 06	M18X1.5	12	7.0	23.4	1.5		22
C-21512 - 06 - 22	10	3/8	- 06	M22X1.5	15	9.5	25.0	2.5		27
C-21512 - 08 - 18	12	1/2	- 08	M18X1.5	12	7.0	29.0	1.0		22
C-21512 - 08 - 22	12	1/2	- 08	M22X1.5	15	9.5	25.4	2.5		27
C-21512 - 08 - 26	12	1/2	- 08	M26X1.5	18	12.0	30.0	2.5		32
C-21512 - 10 - 26	16	5/8	- 10	M26X1.5	18	12.0	29.0	2.5		32
C-21512 - 10 - 30	16	5/8	- 10	M30X2.0	22	15.0	34.0	4.0		36
C-21512 - 12 - 30	19	3/4	- 12	M30X2.0	22	15.0	35.0	4.0		36
C-21512 - 16 - 36	25	1	- 16	M36X2.0	28	19.0	38.2	4.0		41

C-21542

(DIN20066/3865)[THRUST WIRE/SLIP-ON]
 45° O’RING METRIC FEMALE 24° CONE
 LIGHT TYPE

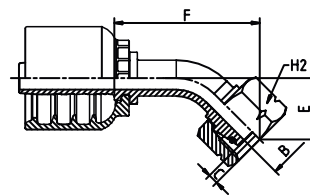

PART. REF. C	HOSE BORE			THREAD	TUBE	DIMENSIONS				
	DN	INCH	SIZE	LT. METRIC	MM	B	F	C	E	H2
C-21542 - 06 - 16	10	3/8	- 06	M16X1.5	10	5.5	23.1	1.5		19
C-21542 - 06 - 18	10	3/8	- 06	M18X1.5	10	7.0	43.5	1.5		22
C-21542 - 06 - 22	10	3/8	- 06	M22X1.5	15	9.5	45.0	2.5		27
C-21542 - 08 - 22	12	1/2	- 08	M22X1.5	15	9.5	52.0	2.5		27
C-21542 - 08 - 26	12	1/2	- 08	M26X1.5	18	12.0	52.5	2.5		32
C-21542 - 10 - 26	16	5/8	- 10	M26X1.5	18	12.0	62.0	2.5		32
C-21542 - 10 - 30	16	5/8	- 10	M30X2.0	22	*	*	*		*

C-21592

(DIN20066/3865)[THRUST WIRE/SLIP-ON]
 90° O’RING METRIC FEMALE 24° CONE
 LIGHT TYPE

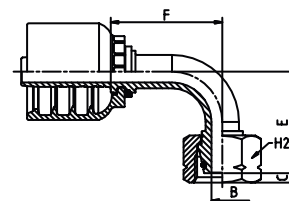

PART. REF. C	HOSE BORE			THREAD	TUBE	DIMENSIONS				
	DN	INCH	SIZE	LT. METRIC	MM	B	F	C	E	H2
C-21592 - 06 - 18	10	3/8	- 06	M18X1.5	12	7.0	36.5	1.5	33.5	22
C-21592 - 06 - 16	10	3/8	- 06	M16X1.5	10	5.5	35.5	1.5	40.0	19
C-21592 - 06 - 22	10	3/8	- 06	M22X1.5	15	9.5	36.5	2.5	35.0	27
C-21592 - 08 - 18	12	1/2	- 08	M18X1.5	12	7.0	44.0	1.0	48.0	22
C-21592 - 08 - 22	12	1/2	- 08	M22X1.5	15	9.5	45.0	2.5	39.5	27
C-21592 - 08 - 26	12	1/2	- 08	M26X1.5	18	12.0	45.0	2.5	40.0	32
C-21592 - 10 - 22	16	5/8	- 10	M22X1.5	15	10.0	53.5	2.5	57.5	27
C-21592 - 10 - 26	16	5/8	- 10	M26X1.5	18	12.0	51.5	2.5	53.0	32
C-21592 - 10 - 30	16	5/8	- 10	M30X2.0	22	15.0	51.5	4.0	54.0	36

C-21612

(DIN20066/3865)[THRUST WIRE/SLIP-ON]
 STRAIGHT O'RING METRIC FEMALE 24° CONE SEAT
 STRONG TYPE HEAVY DUTY

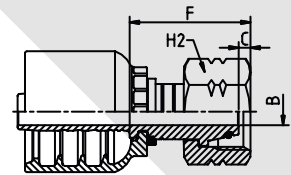

PART. REF. C	HOSE BORE			THREAD	TUBE	DIMENSIONS				
	DN	INCH	SIZE	HT. METRIC	MM	B	F	C		H2
C-21612 - 06 - 18	10	3/8	- 06	M18X1.5	10	5.0	28.5	1.0		22
C-21612 - 06 - 20	10	3/8	- 06	M20X1.5	12	7.0	25.3	2.5		24
C-21612 - 06 - 22	10	3/8	- 06	M22X1.5	14	7.0	32.6	2.5		27
C-21612 - 08 - 20	12	1/2	- 08	M20X1.5	12	8.0	29.0	2.0		24
C-21612 - 08 - 22	12	1/2	- 08	M22X1.5	14	9.5	27.5	2.5		27
C-21612 - 08 - 24	12	1/2	- 08	M24X1.5	16	9.5	26.7	3.0		30
C-21612 - 10 - 30	12	1/2	- 08	M30X2.0	20	12.0	30.6	3.5		36
C-21612 - 12 - 30	19	3/4	- 12	M30X2.0	20	15.0	34.0	3.5		36
C-21612 - 12 - 36	19	3/4	- 12	M36X2.0	25	15.0	32.5	5.0		46
C-21612 - 16 - 36	25	1	- 16	M36X2.0	25	20.0	37.2	5.0		46
C-21612 - 16 - 42	25	1	- 16	M42X2.0	30	20.0	38.2	5.0		50
C-21612 - 16 - 52	25	1	- 16	M52X2.0	38	28.0	36.2	6.5		60
C-21612 - 20 - 42	31	1.1/4	- 20	M42X2.0	30	20.0	38.2	4.0		50
C-21612 - 20 - 52	31	1.1/4	- 20	M52X2.0	38	26.0	39.2	6.5		60
C-21612 - 24 - 52	38	1.1/2	- 24	M52X2.0	38	30.0	47.0	6.5		60

C-21642

(DIN20066/3865)[THRUST WIRE/SLIP-ON]
 45° O'RING METRIC FEMALE 24° CONE SEAT
 STRONG TYPE HEAVY DUTY

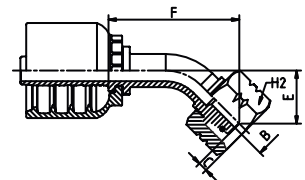

PART. REF. C	HOSE BORE			THREAD	TUBE	DIMENSIONS				
	DN	INCH	SIZE	HT. METRIC	MM	B	F	C	E	H2
C-21642 - 06 - 18	10	3/8	- 06	M18X1.5	10	5.0	49.0	1.0	23.0	22
C-21642 - 06 - 20	10	3/8	- 06	M20X1.5	12	7.0	45.0	2.5	18.0	24
C-21642 - 06 - 22	10	3/8	- 06	M22X1.5	14	7.0	46.5	2.5	19.5	27
C-21642 - 08 - 22	10	3/8	- 06	M22X1.5	14	9.5	57.5	2.5	25.5	27
C-21642 - 08 - 24	10	3/8	- 06	M24X1.5	16	9.5	52.5	3.0	20.0	30
C-21642 - 10 - 30	16	5/8	- 10	M30X2.0	20	15.0	65.5	3.5	29.5	36
C-21642 - 12 - 30	19	3/4	- 12	M30X2.0	20	15.0	76.7	3.5	30.5	36
C-21642 - 12 - 36	19	3/4	- 12	M36X2.0	25	15.0	76.3	5.0	30.9	46
C-21642 - 16 - 36	25	1	- 16	M36X2.0	25	19.0	85.1	5.0	33.5	46
C-21642 - 16 - 42	25	1	- 16	M42X2.0	30	19.0	89.5	5.0	35.0	50
C-21642 - 20 - 42	31	1.1/4	- 20	M42X2.0	30	26.0	107.0	5.0	42.6	50
C-21642 - 20 - 52	31	1.1/4	- 20	M52X2.0	38	26.0	104.0	6.5	39.5	60

C-21692

(DIN20066/3865)[THRUST WIRE/SLIP-ON]
90° O'RING METRIC FEMALE 24° CONE SEAT
STRONG TYPE HEAVY DUTY

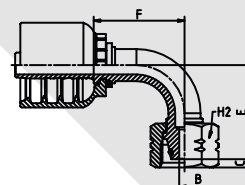

PART. REF. C	HOSE BORE			THREAD	TUBE	DIMENSIONS				
	DN	INCH	SIZE	HT. METRIC	MM	B	F	C	E	H2
C-21692 - 06 - 18	10	3/8	- 06	M18X1.5	10	5.0	35.5	1.0	42.5	22
C-21692 - 06 - 20	10	3/8	- 06	M20X1.5	12	7.0	36.5	2.5	35.0	24
C-21692 - 06 - 22	10	3/8	- 06	M22X1.5	14	7.0	36.5	2.5	37.0	27
C-21692 - 06 - 24	10	3/8	- 06	M24X1.5	16	10.0	36.5	3.0	36.0	30
C-21692 - 08 - 22	12	1/2	- 08	M22X1.5	14	9.5	44.0	2.5	48.5	27
C-21692 - 08 - 24	12	1/2	- 08	M24X1.5	16	9.5	45.0	3.0	40.5	30
C-21692 - 10 - 30	16	5/8	- 10	M30X2.0	20	12.0	51.5	3.5	57.5	36
C-21692 - 12 - 30	19	3/4	- 12	M30X2.0	20		65.5	3.5	62.5	36
C-21692 - 12 - 36	19	3/4	- 12	M36X2.0	25					
C-21692 - 16 - 36	25	1	- 16	M36X2.0	25					
C-21692 - 16 - 42	25	1	- 16	M42X2.0	30					
C-21692 - 20 - 42	31	1.1/4	- 20	M42X2.0	30					
C-21692 - 20 - 52	31	1.1/4	- 20	M52X2.0	38					

C-21713

[THRUST WIRE]
FRENCH METRIC FEMALE MILLIMETRIC TYPE
MILLIMETRIC TYPE

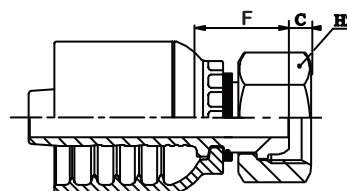

PART. REF. C	HOSE BORE			THREAD	TUBE	DIMENSIONS				
	DN	INCH	SIZE	FR. METRIC	MM	B	F	C	H2	
C-21713 - 10 - 2718	16	5/8	- 10	M27X1.5	18	12.5	22.2	5.1		32
C-21713 - 10 - 2720	16	5/8	- 10	M27X1.5	20	12.5	22.2	5.1		32

C-21813

[THRUST WIRE]
FRENCH METRIC FEMALE
GAZ TYPE

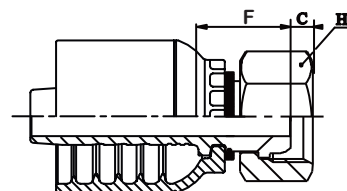

PART. REF. C	HOSE BORE			THREAD	TUBE	DIMENSIONS				
	DN	INCH	SIZE	FR. METRIC	MM	B	F	C	H2	
C-21813 - 06 - 20	10	3/8	- 06	M20X1.5	13.25	7.0	22.6	4.3		24
C-21813 - 06 - 24	10	3/8	- 06	M24X1.5	16.75	9.3	25.6	4.0		30
C-21813 - 08 - 24	12	1/2	- 08	M24X1.5	16.75	9.3	26.5	4.0		30
C-21813 - 08 - 30	12	1/2	- 08	M30X1.5	21.25	12.5	23.6	5.1		36
C-21813 - 10 - 30	16	5/8	- 10	M30X1.5	21.25	12.5	23.7	5.1		36

C-21893

[THRUST WIRE]

90° FRENCH METRIC FEMALE
GAZ TYPE

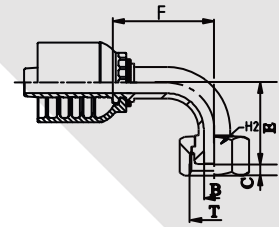

PART. REF. C	HOSE BORE			THREAD	TUBE	DIMENSIONS				
	DN	INCH	SIZE	FR. METRIC	MM	B	F	C	E	H2
C-21893 - 06 - 20	10	3/8	- 06	M20X1.5	13.25	7.0	36.5	4.3	33.5	24
C-21893 - 08 - 24	12	1/2	- 08	M24X1.5	16.75	12.0	45.0	4.0	41.0	30
C-21893 - 10 - 30	16	5/8	- 10	M30X1.5	21.25	12.5	51.5	5.1	53.5	36

C-22010

(DIN2353)

METRIC STANDPIPE STRAIGHT

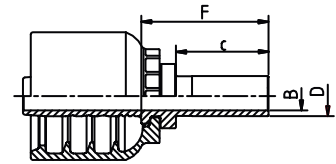

PART. REF. C	HOSE BORE			DIMENSIONS						
	DN	INCH	SIZE	B	F	C	D			
C-22010 - 06 - 10	10	3/8	- 06	7.0	30.0	20.0	10.0			
C-22010 - 06 - 12	10	3/8	- 06	7.0	30.6	23.0	12.0			
C-22010 - 06 - 14	10	3/8	- 06	8.0	36.6	29.0	14.0			
C-22010 - 06 - 15	10	3/8	- 06	*	*	*	*			
C-22010 - 08 - 12	12	1/2	- 08	9.5	30.9	21.0	12.0			
C-22010 - 08 - 14	12	1/2	- 08	9.3	36.9	29.0	14.0			
C-22010 - 08 - 15	12	1/2	- 08	9.5	32.9	24.0	15.0			
C-22010 - 08 - 16	12	1/2	- 08	9.5	37.9	29.0	16.0			
C-22010 - 08 - 18	12	1/2	- 08	9.5	33.9	25.0	18.0			
C-22010 - 10 - 18	16	5/8	- 10	12.5	34.2	26.0	18.0			
C-22010 - 10 - 20	16	5/8	- 10	12.5	44.2	36.0	20.0			
C-22010 - 10 - 22	16	5/8	- 10	15.0	36.2	28.0	22.0			

C-22040

(DIN2353)

45° METRIC STANDPIPE

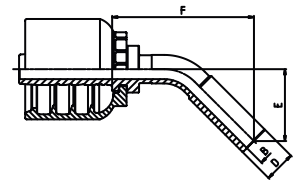

PART. REF. C	HOSE BORE			DIMENSIONS						
	DN	INCH	SIZE	B	F	D	E			
C-22040 - 06 - 10	10	3/8	- 06	7.0	51.0	10.0	26.5			
C-22040 - 06 - 12	10	3/8	- 06	8.0	49.5	12.0	25.0			
C-22040 - 06 - 14	10	3/8	- 06	9.3	54.5	14.0	29.0			
C-22040 - 08 - 14	12	1/2	- 08	*	*	*	*			
C-22040 - 08 - 15	12	1/2	- 08	9.5	59.4	15.0	29.4			
C-22040 - 08 - 16	12	1/2	- 08	9.5	66.0	16.0	35.0			
C-22040 - 10 - 18	16	5/8	- 10	12.0	63.5	18.0	30.5			
C-22040 - 10 - 20	16	5/8	- 10	12.0	85.0	20.0	40.0			

C-22090
 (DIN2353)
 90° METRIC STANDPIPE

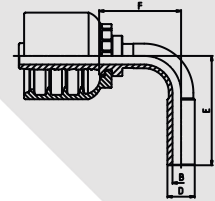

PART. REF. C	HOSE BORE			DIMENSIONS					
	DN	INCH	SIZE	B	F	D	E		
C-22090 - 06 - 10	10	3/8	- 06	7.0	34.0	10.0	47.5		
C-22090 - 06 - 12	10	3/8	- 06	7.0	34.0	12.0	49.0		
C-22090 - 06 - 14	10	3/8	- 06	9.3	42.0	14.0	53.5		
C-22090 - 08 - 14	12	1/2	- 08	9.5	42.0	14.0	53.5		
C-22090 - 08 - 15	12	1/2	- 08	10.5	42.0	15.0	52.0		
C-22090 - 08 - 16	12	1/2	- 08	10.5	43.0	16.0	55.0		
C-22090 - 08 - 18	12	1/2	- 08	9.5	48.5	18.0	58.0		
C-22090 - 10 - 18	16	5/8	- 10	12.5	49.0	18.0	59.0		
C-22090 - 10 - 20	16	5/8	- 10	12.5	49.0	20.0	66.5		
C-22090 - 10 - 22	16	5/8	- 10	12.0	55.0	20.0	72.0		

C-11310

SAE FLARELESS MALE ASSEMBLY

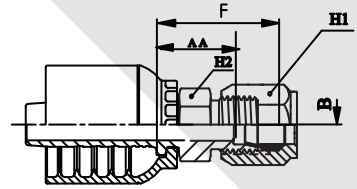

PART. REF. C	HOSE BORE			THREAD	DIMENSIONS					
	DN	INCH	SIZE	ERMETO	B	F	TUBE	AA	H1	H2
C-11310 - 06 - 04	10	3/8	- 06	7/16 - 20	4.0	27.1	1/4	21.0	14	17
C-11310 - 06 - 05	10	3/8	- 06	1/2 - 20	6.0	27.1	5/16	20.6	16	17
C-11310 - 06 - 06	10	3/8	- 06	9/16 - 18	7.0	28.1	3/8	21.6	17.5	17
C-11310 - 06 - 08	10	3/8	- 06	3/4 - 16	10.0	33.1	1/2	25.2	22	22
C-11310 - 08 - 08	12	1/2	- 08	3/4 - 16	9.5	33.0	1/2	25.1	22	22
C-11310 - 08 - 10	12	1/2	- 08	7/8 - 14	12.5	34.5	5/8	25.5	25.5	22

C-12610

(SAE J516/J512)

SAE MALE 45° CONE SEAT

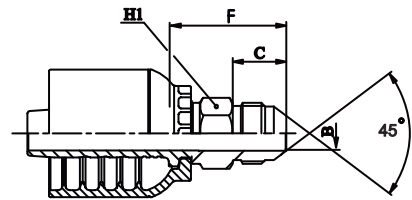

PART. REF. C	HOSE BORE			THREAD	DIMENSIONS					
	DN	INCH	SIZE	SAE 45°	B	F	C			H1
C-12610 - 06 - 06	10	3/8	- 06	5/8 - 18	7.0	29.6	14.0			17

C-12910

(DIN20066/3865)

STRAIGHT MALE INVERTED FLARE

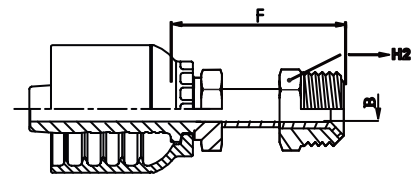

PART. REF. C	HOSE BORE			THREAD	DIMENSIONS					
	DN	INCH	SIZE	INVERTED	B	F	TUBE			H2
C-12910 - 06 - 04	10	3/8	- 06	7/16 - 24	*	*	*			*
C-12910 - 06 - 05	10	3/8	- 06	1/2 - 20	7.0	48.0	5/16			14
C-12910 - 06 - 06	10	3/8	- 06	5/8 - 18	7.0	50.0	3/8			17
C-12910 - 06 - 07	10	3/8	- 06	11/16 - 18	*	*	*			*
C-12910 - 06 - 08	10	3/8	- 06	3/4 - 18	*	*	*			*
C-12910 - 08 - 08	12	1/2	- 08	3/4 - 18	9.5	51.0	1/2			19
C-12910 - 08 - 10	12	1/2	- 08	7/8 - 18	*	*	*			*

C-12940
 (SAE J516/J512)
 45° MALE INVERTED FLARE

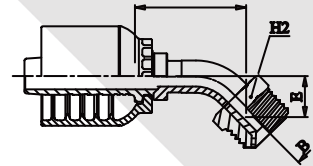

PART. REF. C	HOSE BORE			THREAD	DIMENSIONS					
	DN	INCH	SIZE	INVERTED	B	F	TUBE	E		H2
C-12940 - 06 - 04	10	3/8	- 06	7/16 - 24	3.9	68.0	1/4	32.0		12
C-12940 - 06 - 05	10	3/8	- 06	1/2 - 20	4.6	70.7	5/16	40.0		14
C-12940 - 06 - 06	10	3/8	- 06	5/8 - 18	6.2	76.0	3/8	38.0		17
C-12940 - 06 - 07	10	3/8	- 06	11/16 - 18	*	*	*	*		*
C-12940 - 06 - 08	10	3/8	- 06	3/4 - 18	*	*	*	*		*
C-12940 - 08 - 08	12	1/2	- 08	3/4 - 18	9.5	82.0	1/2	46.0		19
C-12940 - 08 - 10	12	1/2	- 08	7/8 - 18	*	*	*	*		*

C-12990
 (SAE J516/J512)
 90° MALE INVERTED FLARE

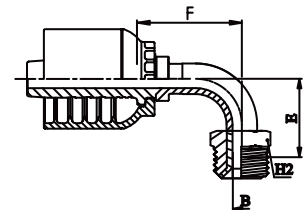

PART. REF. C	HOSE BORE			THREAD	DIMENSIONS					
	DN	INCH	SIZE	INVERTED	B	F	TUBE	E		H2
C-12990 - 06 - 04	10	3/8	- 06	7/16 - 24	3.9	40.0	1/4	57.0		12
C-12990 - 06 - 05	10	3/8	- 06	1/2 - 20	4.6	40.0	5/16	62.0		14
C-12990 - 06 - 06	10	3/8	- 06	5/8 - 18	6.2	40.0	3/8	62.0		17
C-12990 - 06 - 07	10	3/8	- 06	11/16 - 18	*	*	*	*		*
C-12990 - 06 - 08	10	3/8	- 06	3/4 - 18	*	*	*	*		*
C-12990 - 08 - 08	12	1/2	- 08	3/4 - 18	9.5	54.0	1/2	65.0		19
C-12990 - 08 - 10	12	1/2	- 08	7/8 - 18	*	*	*	*		*

C-22612
 (DIN 20066/3865)[THRUST WIRE]
 SAE FEMALE STRAIGHT 45° FLARE

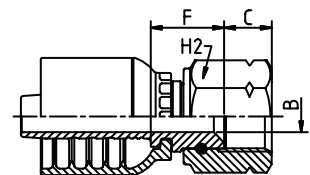

PART. REF. C	HOSE BORE			THREAD	DIMENSIONS					
	DN	INCH	SIZE	SAE 45°	B	F	C			H2
C-22612 - 06 - 06	10	3/8	- 06	7/16 - 20	7.0	16.6	10.8			22

C-22642

(DIN 20066/3865)[THRUST WIRE]
45° SAE FEMALE 45° FLARE

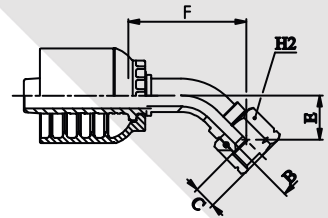

PART. REF. C	HOSE BORE			THREAD	DIMENSIONS					
	DN	INCH	SIZE	SAE 45°	B	F	C	E	H2	
C-22642 - 06 - 06	10	3/8	- 06	5/8 - 18	7.0	42.0	10.8	16.5	22	

C-22692

(DIN 20066/3865)[THRUST WIRE]
90° SAE FEMALE 45° FLARE

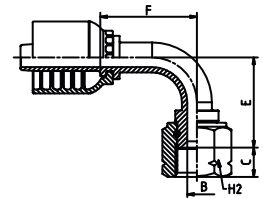

PART. REF. C	HOSE BORE			THREAD	DIMENSIONS					
	DN	INCH	SIZE	SAE 45°	B	F	C	E	H2	
C-22692 - 06 - 06	10	3/8	- 06	9/16 - 18	7.0	35.5	10.8	33.0	22	

C-23811**(JIS B 8363)[CRIMP BACK]**

FEMALE STRAIGHT "JIS" BSP STYLE 60° CONE SEAT (TOYOTA)

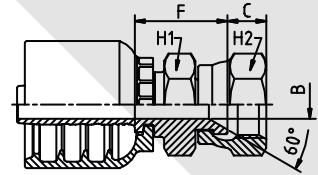

PART. REF. C	HOSE BORE			THREAD	DIMENSIONS					
	DN	INCH	SIZE	JIS	B	F	C	H1	H2	
C-23811 - 06 - 06	10	3/8	- 06	3/8 - 19	7.0	23.1	10.0	22	22	
C-23811 - 08 - 08	12	1/2	- 08	1/2 - 14	9.5	27.0	11.5	27	27	
C-23811 - 10 - 10	16	5/8	- 10	5/8 - 14	15.0	30.0	13.6	32	32	

C-23891**(JIS B 8363)[CRIMP BACK]**

FEMALE 90° "JIS" BSP STYLE 60° CONE SEAT (TOYOTA)

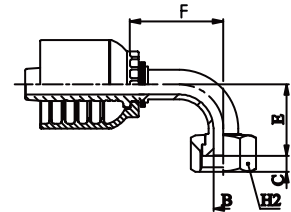

PART. REF. C	HOSE BORE			THREAD	DIMENSIONS					
	DN	INCH	SIZE	JIS	B	F	C	E	H2	
C-23891 - 06 - 06	10	3/8	- 06	3/8 - 19	7.0	37.0	10.0	38.0	22	
C-23891 - 08 - 08	12	1/2	- 08	1/2 - 14	9.5	47.5	11.5	40.0	27	

C-24011**(JIS B 8363)[CRIMP BACK]**

JIS METRIC FEMALE 60° CONE SEAT (KOMATSU)

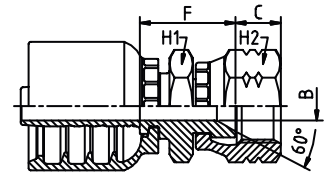

PART. REF. C	HOSE BORE			THREAD	DIMENSIONS					
	DN	INCH	SIZE	JIS	B	F	C	H1	H2	
C-24011 - 06 - 14	10	3/8	- 06	M14X1.5	7.0	23.3	10.5	19	19	
C-24011 - 06 - 16	10	3/8	- 06	M16X1.5	*	*	*	*	*	
C-24011 - 06 - 18	10	3/8	- 06	M18X1.5	7.0	25.0	11.5	24	24	
C-24011 - 06 - 20	10	3/8	- 06	M20X1.5	*	*	*	*	*	
C-24011 - 06 - 22	10	3/8	- 06	M22X1.5	*	*	*	*	*	
C-24011 - 08 - 18	12	1/2	- 08	M18X1.5	*	*	*	*	*	
C-24011 - 08 - 22	12	1/2	- 08	M22X1.5	9.5	27.7	14.0	27	27	
C-24011 - 08 - 24	12	1/2	- 08	M24X1.5	*	*	*	*	*	
C-24011 - 10 - 24	16	5/8	- 10	M24X1.5	12.0	30.5	15.0	32	32	

C-24041**(JIS B 8363)[CRIMP BACK]**

45° JIS METRIC FEMALE 60° CONE SEAT (KOMATSU)

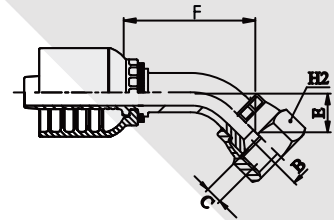

PART. REF. C	HOSE BORE			THREAD	DIMENSIONS					
	DN	INCH	SIZE	JIS	B	F	C	E		H2
C-24041 - 06 - 18	10	3/8	- 06	M18X1.5	*	*	*	*		*
C-24041 - 08 - 22	12	1/2	- 08	M22X1.5	*	*	*	*		*
C-24041 - 08 - 24	12	1/2	- 08	M24X1.5	*	*	*	*		*
C-24041 - 10 - 24	16	5/8	- 10	M24X1.5	*	*	*	*		*

C-24091**(JIS B 8363)[CRIMP BACK]**

90° JIS METRIC FEMALE 60° CONE SEAT (KOMATSU)

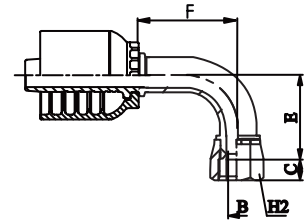

PART. REF. C	HOSE BORE			THREAD	DIMENSIONS					
	DN	INCH	SIZE	JIS	B	F	C	E		H2
C-24091 - 06 - 18	10	3/8	- 18	M18X1.5	*	*	*	*		*
C-24091 - 08 - 22	12	1/2	- 08	M22X1.5	*	*	*	*		*
C-24091 - 10 - 24	16	1	- 10	M24X1.5	*	*	*	*		*

C-24913

FEMALE "KARCHER" STYLE

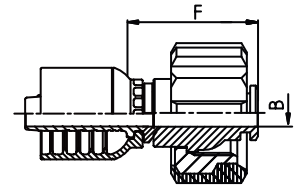

PART. REF. C	HOSE BORE			THREAD	DIMENSIONS					
	DN	INCH	SIZE	T	B	F				
C-24913 - 06 - 22	10	3/8	- 06	M22X1.5	7.0	30.0				

C-10050
HOSE MENDER

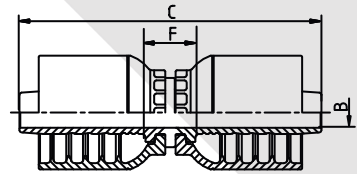

PART. REF. C	HOSE BORE			DIMENSIONS					
	DN	INCH	SIZE	B	F	C			
C-10050 - 06 - 06	10	3/8	- 06	7.0	14.7	78.3			
C-10050 - 08 - 08	12	1/2	- 08	9.5	15.8	91.8			
C-10050 - 10 - 10	16	5/8	- 10	12.0	15.4	98.4			

C-12H10
STRAIGHT MALE "EASY PUSH" INSERT

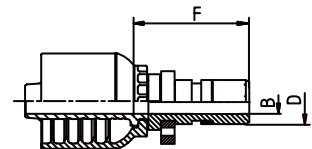

PART. REF. C	HOSE BORE			DIMENSIONS					
	DN	INCH	SIZE	B	F	D			
C-12H10 - 06 - 04	10	3/8	- 06	4.0	30.5	10.0			
C-12H10 - 06 - 06	10	3/8	- 06	7.0	34.5	13.0			
C-12H10 - 06 - 08	10	3/8	- 06	9.3	34.5	16.0			
C-12H10 - 08 - 06	12	1/2	- 08	7.0	35.0	13.0			
C-12H10 - 08 - 08	12	1/2	- 08	9.3	35.0	16.0			
C-12H10 - 10 - 08	16	5/8	- 10	9.3	35.0	16.0			

C-12H40
45° MALE "EASY PUSH" INSERT

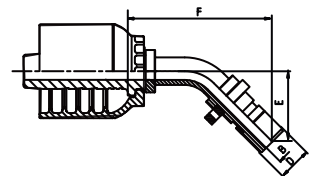

PART. REF. C	HOSE BORE			DIMENSIONS					
	DN	INCH	SIZE	B	F	D	F		
C-12H40 - 06 - 04	10	3/8	- 06	4.0	47.0	10.0	23.5		
C-12H40 - 06 - 06	10	3/8	- 06	7.0	55.5	13.0	28.0		
C-12H40 - 08 - 08	12	1/2	- 08	9.3	61.5	16.0	30.0		

C-12H90

90° MALE "EASY PUSH" INSERT

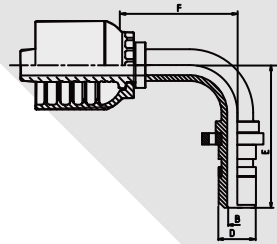

PART. REF. C	HOSE BORE			DIMENSIONS					
	DN	INCH	SIZE	B	F	D	E		
C-12H90 - 06 - 04	10	3/8	- 06	4.0	30.5	10.0	40.0		
C-12H90 - 06 - 06	10	3/8	- 06	7.0	37.0	13.0	49.0		
C-12H90 - 08 - 08	12	1/2	- 08	9.3	44.0	16.0	55.0		



05125

REUSABLE HOSE ENDS FOR 100R5 / MALE JIC

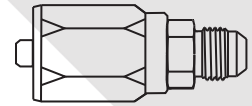

PART. REF.	COMPONENTS			
	SIZE	FERRULE	FITTING	THREAD
05125 - 04 - 04	- 04	R305 - 04	R125 - 03 - 04	7/16 - 20
05125 - 05 - 04	- 05	R305 - 05	R125 - 04 - 04	7/16 - 20
05125 - 05 - 05	- 05	R305 - 05	R125 - 04 - 05	1/2 - 20
05125 - 06 - 06	- 06	R305 - 06	R125 - 05 - 06	9/16 - 18
05125 - 08 - 06	- 08	R305 - 08	R125 - 06 - 06	9/16 - 18
05125 - 08 - 08	- 08	R305 - 08	R125 - 06 - 08	3/4 - 16
05125 - 10 - 08	- 10	R305 - 10	R125 - 08 - 08	3/4 - 16
05125 - 10 - 10	- 10	R305 - 10	R125 - 08 - 10	7/8 - 14
05125 - 12 - 10	- 12	R305 - 12	R125 - 10 - 10	7/8 - 14
05125 - 12 - 12	- 12	R305 - 12	R125 - 10 - 12	1.1/16 - 12
05125 - 16 - 16	- 16	R305 - 16	R125 - 12 - 16	1.5/16 - 12
05125 - 20 - 20	- 20	R305 - 20	R125 - 18 - 20	1.5/8 - 12
05125 - 24 - 24	- 24	R305 - 24	R125 - 22 - 24	1.7/8 - 12

05126

REUSABLE HOSE ENDS FOR 100R5 / MALE SAE

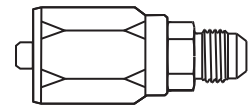

PART. REF.	COMPONENTS			
	SIZE	FERRULE	FITTING	THREAD
05126 - 06 - 06	- 06	R305 - 06	R126 - 05 - 06	5/8 - 18

05128

REUSABLE HOSE ENDS FOR 100R5 / MALE NPT

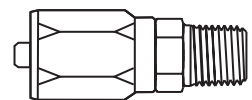

PART. REF.	COMPONENTS			
	SIZE	FERRULE	FITTING	THREAD
05128 - 04 - 02	- 04	R305 - 04	R128 - 03 - 02	1/8 - 27
05128 - 04 - 04	- 04	R305 - 04	R128 - 03 - 04	1/4 - 18
05128 - 05 - 04	- 05	R305 - 05	R128 - 04 - 04	1/4 - 18
05128 - 06 - 04	- 06	R305 - 06	R128 - 05 - 04	1/4 - 18
05128 - 06 - 06	- 06	R305 - 06	R128 - 05 - 06	3/8 - 18
05128 - 08 - 06	- 08	R305 - 08	R128 - 06 - 06	3/8 - 18
05128 - 08 - 08	- 08	R305 - 08	R128 - 08 - 08	1/2 - 14
05128 - 10 - 08	- 10	R305 - 10	R128 - 08 - 12	3/4 - 14
05128 - 10 - 12	- 10	R305 - 10	R128 - 08 - 12	3/4 - 14
05128 - 12 - 12	- 12	R305 - 12	R128 - 10 - 12	3/4 - 14
05128 - 16 - 16	- 16	R305 - 16	R128 - 14 - 16	1 - 11.5
05128 - 20 - 20	- 20	R305 - 20	R128 - 18 - 20	1.1/4 - 11.5
05128 - 24 - 24	- 24	R305 - 24	R128 - 22 - 24	1.1/2 - 11.5
05128 - 32 - 32	- 32	R305 - 32	R128 - 29 - 32	2 - 11.5

05205

REUSABLE HOSE ENDS FOR 100R5 / FEMALE BSP

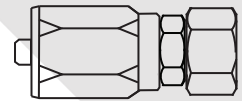

PART. REF.	COMPONENTS			
	SIZE	FERRULE	FITTING	THREAD
05205 - 05 - 04	- 05	R305 - 05	R205 - 04 - 04	1/4 - 19
05205 - 08 - 06	- 08	R305 - 08	R205 - 06 - 06	3/8 - 19
05205 - 10 - 08	- 10	R305 - 10	R205 - 08 - 08	1/2 - 14
05205 - 12 - 10	- 12	R305 - 12	R205 - 10 - 10	5/8 - 14

05209

REUSABLE HOSE ENDS FOR 100R5 / FEMALE BSP 90°

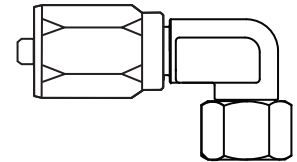

PART. REF.	COMPONENTS			
	SIZE	FERRULE	FITTING	THREAD
05209 - 05 - 04	- 05	R305 - 05	R209 - 04 - 04	1/4 - 19
05209 - 08 - 06	- 08	R305 - 08	R209 - 06 - 06	3/8 - 19
05209 - 10 - 08	- 10	R305 - 10	R209 - 08 - 08	1/2 - 14
05209 - 12 - 10	- 12	R305 - 12	R209 - 10 - 10	5/8 - 14

05225/05235

REUSABLE HOSE ENDS FOR 100R5 / FEMALE JIC SWIVEL

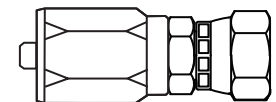

PART. REF.	COMPONENTS			
	SIZE	FERRULE	FITTING	THREAD
05225 - 04 - 04	- 04	R305 - 04	R225 - 03 - 04	7/16 - 20
05225 - 05 - 04	- 05	R305 - 05	R225 - 04 - 04	7/16 - 20
05225 - 05 - 05	- 05	R305 - 05	R225 - 04 - 05	1/2 - 20
05225 - 05 - 06	- 05	R305 - 05	R225 - 04 - 06	9/16 - 18
05225 - 05 - 08	- 05	R305 - 05	R225 - 04 - 08	3/4 - 16
05225 - 06 - 06	- 06	R305 - 06	R225 - 05 - 06	9/16 - 18
05225 - 06 - 08	- 06	R305 - 06	R225 - 05 - 08	3/4 - 16
05225 - 08 - 04	- 08	R305 - 08	R225 - 06 - 04	7/16 - 20
05225 - 08 - 05	- 08	R305 - 08	R225 - 06 - 05	1/2 - 20
05225 - 08 - 06	- 08	R305 - 08	R225 - 06 - 06	9/16 - 18
05225 - 08 - 08	- 08	R305 - 08	R225 - 06 - 08	3/4 - 16
05225 - 08 - 10	- 08	R305 - 08	R225 - 06 - 10	7/8 - 14
05225 - 10 - 08	- 10	R305 - 10	R225 - 08 - 08	3/4 - 16
05225 - 10 - 10	- 10	R305 - 10	R225 - 08 - 10	7/8 - 14
05225 - 10 - 12	- 10	R305 - 10	R225 - 08 - 12	1.1/16 - 12
05225 - 12 - 10	- 12	R305 - 12	R225 - 10 - 10	7/8 - 14
05225 - 12 - 12	- 12	R305 - 12	R225 - 10 - 12	1.1/16 - 12
05225 - 16 - 16	- 16	R305 - 16	R225 - 14 - 16	1.5/16 - 12
05235 - 20 - 20	- 20	R305 - 20	R235 - 18 - 20	1.5/8 - 12
05235 - 24 - 24	- 24	R305 - 24	R235 - 22 - 24	1.7/8 - 12
05235 - 32 - 32	- 32	R305 - 32	R235 - 29 - 32	2.1/2 - 12

05226

REUSABLE HOSE ENDS FOR 100R5 / FEMALE JIC SAE SWIVEL

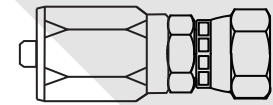

PART. REF.	COMPONENTS			
	SIZE	FERRULE	FITTING	THREAD
05226 - 04 - 04	- 04	R305 - 04	R226 - 03 - 04	7/16 - 20
05226 - 06 - 06	- 06	R305 - 06	R226 - 05 - 06	9/16 - 18
05226 - 08 - 08	- 08	R305 - 08	R226 - 06 - 08	3/4 - 16
05226 - 12 - 12	- 12	R305 - 12	R226 - 10 - 12	1.1/16 - 12

05245

REUSABLE HOSE ENDS FOR 100R5 / FEMALE JIC SWIVEL 45°

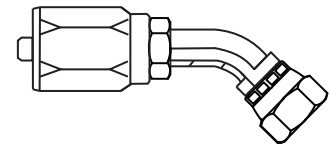

PART. REF.	COMPONENTS			
	SIZE	FERRULE	FITTING	THREAD
05245 - 04 - 04	- 04	R305 - 04	R245 - 03 - 04	7/16 - 20
05245 - 06 - 06	- 06	R305 - 06	R245 - 05 - 06	9/16 - 18
05245 - 10 - 08	- 10	R305 - 10	R245 - 08 - 08	3/4 - 16
05245 - 10 - 10	- 10	R305 - 10	R245 - 08 - 10	7/8 - 14
05245 - 16 - 16	- 16	R305 - 16	R245 - 14 - 16	1.5/16 - 12

05291

REUSABLE HOSE ENDS FOR 100R5 / FEMALE JIC

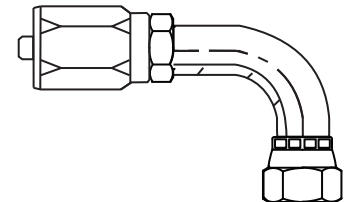

PART. REF.	COMPONENTS			
	SIZE	FERRULE	FITTING	THREAD
05291 - 04 - 04	- 04	R305 - 04	R291 - 03 - 04	7/16 - 20
05291 - 06 - 06	- 06	R305 - 06	R291 - 05 - 06	9/16 - 18
05291 - 08 - 06	- 08	R305 - 08	R291 - 06 - 06	9/16 - 18
05291 - 08 - 08	- 08	R305 - 08	R291 - 06 - 08	3/4 - 16
05291 - 10 - 10	- 10	R305 - 10	R291 - 08 - 10	7/8 - 14
05291 - 12 - 12	- 12	R305 - 12	R291 - 10 - 12	1.1/16 - 12
05291 - 16 - 16	- 16	R305 - 16	R291 - 14 - 16	1.5/16 - 12

31125

REUSABLE HOSE ENDS FOR 100R1AT / MALE JIC

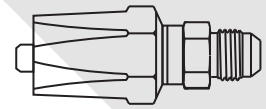

PART. REF.	COMPONENTS			
	SIZE	FERRULE	FITTING	THREAD
31125 - 04 - 04	- 04	R310 - 04	R125 - 04 - 04	7/16 - 20
31125 - 06 - 06	- 06	R310 - 06	R125 - 06 - 06	9/16 - 18
31125 - 08 - 08	- 08	R310 - 08	R125 - 08 - 08	3/4 - 16
31125 - 12 - 12	- 12	R310 - 12	R125 - 12 - 12	1.1/16 - 12

31128

REUSABLE HOSE ENDS FOR 100R1AT / MALE NPT

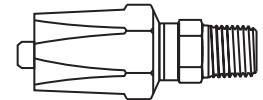

PART. REF.	COMPONENTS			
	SIZE	FERRULE	FITTING	THREAD
31128 - 04 - 02	- 04	R310 - 04	R128 - 04 - 02	1/8 - 27
31128 - 04 - 04	- 04	R310 - 04	R128 - 04 - 04	1/4 - 18
31128 - 06 - 06	- 06	R310 - 06	R128 - 06 - 06	3/8 - 18
31128 - 08 - 08	- 08	R310 - 08	R128 - 08 - 08	1/2 - 14
31128 - 12 - 12	- 12	R310 - 12	R128 - 12 - 12	3/4 - 14
31128 - 16 - 16	- 16	R310 - 16	R128 - 16 - 16	1 - 11.5

31158

REUSABLE HOSE ENDS FOR 100R1AT / MALE NPT SWIVEL

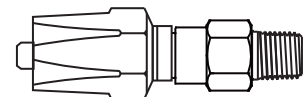

PART. REF.	COMPONENTS			
	SIZE	FERRULE	FITTING	THREAD
31158 - 06 - 06	- 06	R310 - 06	R158 - 06 - 06	3/8 - 18

31205

REUSABLE HOSE ENDS FOR 100R1AT / FEMALE BSP

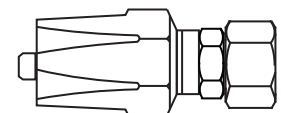

PART. REF.	COMPONENTS			
	SIZE	FERRULE	FITTING	THREAD
31205 - 04 - 04	- 04	R310 - 04	R205 - 04 - 04	1/4 - 19
31205 - 06 - 06	- 06	R310 - 06	R205 - 06 - 06	3/8 - 19
31205 - 08 - 08	- 08	R310 - 08	R205 - 08 - 08	1/2 - 14

31209

REUSABLE HOSE ENDS FOR 100R1AT / FEMALE BSP 90°

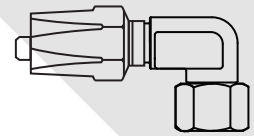

PART. REF.	COMPONENTS			
	SIZE	FERRULE	FITTING	THREAD
31209 - 04 - 04	- 04	R310 - 04	R209 - 04 - 04	1/4 - 19
31209 - 06 - 06	- 06	R310 - 06	R209 - 06 - 06	3/8 - 19
31209 - 08 - 08	- 08	R310 - 08	R209 - 08 - 08	1/2 - 14

31224

REUSABLE HOSE ENDS FOR 100R1AT / FEMALE ORFS

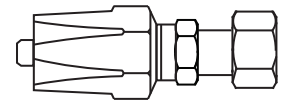

PART. REF.	COMPONENTS			
	SIZE	FERRULE	FITTING	THREAD
31224 - 06 - 06	- 06	R310 - 06	R224 - 06 - 06	11/16 - 16
31224 - 08 - 08	- 08	R310 - 08	R224 - 08 - 08	13/16 - 16

31225

REUSABLE HOSE ENDS FOR 100R1AT / FEMALE JIC SWIVEL

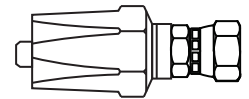

PART. REF.	COMPONENTS			
	SIZE	FERRULE	FITTING	THREAD
31225 - 04 - 04	- 04	R310 - 04	R225 - 04 - 04	7/16 - 20
31225 - 04 - 06	- 04	R310 - 04	R225 - 04 - 06	9/16 - 18
31225 - 06 - 06	- 06	R310 - 06	R225 - 06 - 06	9/16 - 18
31225 - 06 - 08	- 06	R310 - 06	R225 - 06 - 08	3/4 - 16
31225 - 08 - 08	- 08	R310 - 08	R225 - 08 - 08	3/4 - 16
31225 - 08 - 10	- 08	R310 - 08	R225 - 08 - 10	7/8 - 14
31225 - 10 - 12	- 10	R310 - 10	R225 - 10 - 12	1.1/16 - 12
31225 - 12 - 12	- 12	R310 - 12	R225 - 12 - 12	1.1/16 - 12
31225 - 16 - 16	- 16	R310 - 16	R225 - 16 - 16	1.5/16 - 12

31291

REUSABLE HOSE ENDS FOR 100R1AT / FEMALE JIC

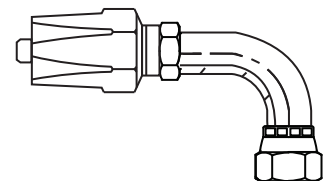

PART. REF.	COMPONENTS			
	SIZE	FERRULE	FITTING	THREAD
31291 - 04 - 04	- 04	R310 - 04	R291 - 04 - 04	7/16 - 20
31291 - 06 - 06	- 06	R310 - 06	R291 - 06 - 06	9/16 - 18
31291 - 08 - 08	- 08	R310 - 08	R291 - 08 - 08	3/4 - 16

32125

REUSABLE HOSE ENDS FOR 100R2AT / MALE JIC

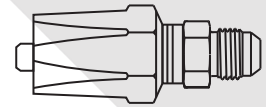

PART. REF.	COMPONENTS			
	SIZE	FERRULE	FITTING	THREAD
32125 - 04 - 04	- 04	R320 - 04	R125 - 04 - 04	7/16 - 20
32125 - 06 - 06	- 06	R320 - 06	R125 - 06 - 06	9/16 - 18
32125 - 06 - 08	- 06	R320 - 06	R125 - 06 - 08	9/16 - 18
32125 - 08 - 08	- 08	R320 - 08	R125 - 08 - 08	3/4 - 16
32125 - 08 - 10	- 08	R320 - 08	R125 - 08 - 10	3/4 - 16
32125 - 10 - 10	- 10	R320 - 10	R125 - 10 - 10	7/8 - 14
32125 - 12 - 12	- 12	R320 - 12	R125 - 12 - 12	1.1/16 - 12
32125 - 16 - 16	- 16	R320 - 16	R125 - 16 - 16	1.5/16 - 12

32128

REUSABLE HOSE ENDS FOR 100R2AT / MALE NPT

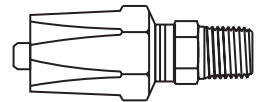

PART. REF.	COMPONENTS			
	SIZE	FERRULE	FITTING	THREAD
32128 - 04 - 02	- 04	R320 - 04	R128 - 04 - 02	1/8 - 27
32128 - 04 - 04	- 04	R320 - 04	R128 - 04 - 04	1/4 - 18
32128 - 04 - 06	- 04	R320 - 04	R128 - 04 - 06	3/8 - 18
32128 - 06 - 04	- 06	R320 - 06	R128 - 06 - 04	1/4 - 18
32128 - 06 - 06	- 06	R320 - 06	R128 - 06 - 06	3/8 - 18
32128 - 08 - 08	- 08	R320 - 08	R128 - 08 - 08	1/2 - 14
32128 - 10 - 08	- 10	R320 - 10	R128 - 10 - 08	1/2 - 14
32128 - 12 - 12	- 12	R320 - 12	R128 - 12 - 12	3/4 - 14
32128 - 16 - 16	- 16	R320 - 16	R128 - 16 - 16	1 - 11.5

32205

REUSABLE HOSE ENDS FOR 100R2AT / FEMALE BSP

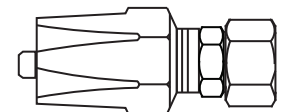

PART. REF.	COMPONENTS			
	SIZE	FERRULE	FITTING	THREAD
32205 - 04 - 04	- 04	R320 - 04	R205 - 04 - 04	1/4 - 19
32205 - 06 - 06	- 06	R320 - 06	R205 - 06 - 06	3/8 - 19
32205 - 08 - 08	- 08	R320 - 08	R205 - 08 - 08	1/2 - 14

32209

REUSABLE HOSE ENDS FOR 100R2AT / FEMALE BSP 90°

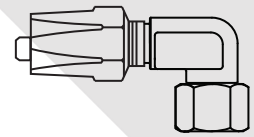

PART. REF.	COMPONENTS			
	SIZE	FERRULE	FITTING	THREAD
32209 - 04 - 04	- 04	R320 - 04	R209 - 04 - 04	1/4 - 19
32209 - 06 - 06	- 06	R320 - 06	R209 - 06 - 06	3/8 - 19
32209 - 08 - 08	- 08	R320 - 08	R209 - 08 - 08	1/2 - 14

32224

REUSABLE HOSE ENDS FOR 100R2AT / FEMALE ORFS

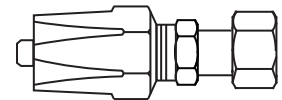

PART. REF.	COMPONENTS			
	SIZE	FERRULE	FITTING	THREAD
32224 - 04 - 04	- 04	R320 - 04	R224 - 04 - 04	9/16 - 18
32224 - 06 - 06	- 06	R320 - 06	R224 - 06 - 06	11/16 - 18
32224 - 08 - 08	- 08	R320 - 08	R224 - 08 - 08	13/16 - 16
32224 - 12 - 12	- 12	R320 - 12	R224 - 12 - 12	1.3/16 - 12

32225

REUSABLE HOSE ENDS FOR 100R2AT / FEMALE JIC SWIVEL

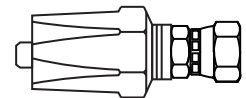

PART. REF.	COMPONENTS			
	SIZE	FERRULE	FITTING	THREAD
32225 - 04 - 04	- 04	R320 - 04	R225 - 04 - 04	7/16 - 20
32225 - 04 - 06	- 04	R320 - 04	R225 - 04 - 06	1/2 - 20
32225 - 06 - 06	- 06	R320 - 06	R225 - 06 - 06	9/16 - 18
32225 - 06 - 08	- 06	R320 - 06	R225 - 06 - 08	3/4 - 16
32225 - 08 - 08	- 08	R320 - 08	R225 - 08 - 08	3/4 - 16
32225 - 08 - 10	- 08	R320 - 08	R225 - 08 - 10	7/8 - 14
32225 - 08 - 12	- 08	R320 - 08	R225 - 08 - 12	1.1/16 - 12
32225 - 10 - 10	- 10	R320 - 10	R225 - 10 - 10	7/8 - 14
32225 - 10 - 12	- 10	R320 - 10	R225 - 10 - 12	1.1/16 - 12
32225 - 12 - 12	- 12	R320 - 12	R225 - 12 - 12	1.1/16 - 12
32225 - 16 - 16	- 16	R320 - 16	R225 - 16 - 16	1.5/16 - 12
32225 - 20 - 20	- 20	R320 - 20	R225 - 20 - 20	1.5/8 - 12
32225 - 24 - 24	- 24	R320 - 24	R225 - 24 - 24	1.7/8 - 12

32226

REUSABLE HOSE ENDS FOR 100R2AT / FEMALE SAE SWIVEL

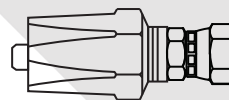

PART. REF.	COMPONENTS			
	SIZE	FERRULE	FITTING	THREAD
32226 - 06 - 06	- 06	R320 - 06	R226 - 06 - 06	5/8 - 18
32226 - 08 - 08	- 08	R320 - 08	R226 - 08 - 08	3/4 - 16

32291

REUSABLE HOSE ENDS FOR 100R2AT / FEMALE JIC

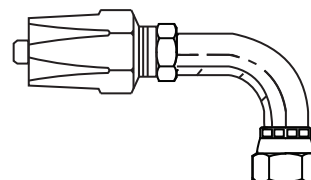

PART. REF.	COMPONENTS			
	SIZE	FERRULE	FITTING	THREAD
32291 - 04 - 04	- 04	R320 - 04	R291 - 04 - 04	7/16 - 20
32291 - 06 - 06	- 06	R320 - 06	R291 - 06 - 06	9/16 - 18
32291 - 06 - 08	- 06	R320 - 06	R291 - 06 - 08	3/4 - 16
32291 - 08 - 08	- 08	R320 - 08	R291 - 08 - 08	3/4 - 16
32291 - 08 - 10	- 08	R320 - 08	R291 - 08 - 10	7/8 - 14
32291 - 10 - 10	- 10	R320 - 10	R291 - 10 - 10	7/8 - 14
32291 - 12 - 12	- 12	R320 - 12	R291 - 12 - 12	1.1/16 - 12
32291 - 16 - 16	- 16	R320 - 16	R291 - 16 - 16	1.5/16 - 12

also available...



SWIVEL

**COMPACT
SERIES**

- Made in USA
- Compact Shape
- Up to 5000psi
- Multiple combination of threads
- NPT/JIC/ORB/ORFS

*Repair kit available

**BEARING
SERIES**

- Made in USA
- Bearing mounted
- Up to 5000psi
- Multiple combination of threads
- NPT/JIC/ORB/ORFS/
BSP

*Repair kit available

**SZ
SERIES (HD)**

- Made in Canada
- Extreme performance
- Up to 6000psi
- Spherical hydraulic joint
- Swivel manifold
- Ideal for forestry and heavy duty application
- Multiple combination of threads
- NPT/JIC/ORB/ORFS/
BSP/METRIC

*Repair kit available



**EMBOUTS “Combination Nipples et Unions”
Combination Nipples & Menders
2020**



**Le Futur, C'est maintenant...
The Future Starts Now...**

COMBINATION NIPPLES & MENDERS

CN

COMBINATION NIPPLE

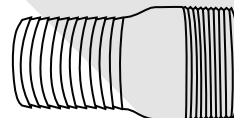

PART. REF.	HOSE / IN.		NPT MALE	
	SIZE	INCH	SIZE	THREAD
CN - 08	- 08	1/2	- 08	1/2 - 14
CN - 12	- 12	3/4	- 12	3/4 - 14
CN - 12 - 16	- 12	3/4	- 16	1 - 11.5
CN - 16	- 16	1	- 16	1 - 11.5
CN - 16 - 12	- 16	1	- 12	3/4 - 14
CN - 16 - 20	- 16	1	- 20	1.1/4 - 11.5
CN - 20	- 20	1.1/4	- 20	1.1/4 - 11.5
CN - 20 - 16	- 20	1.1/4	- 16	1 - 11.5
CN - 20 - 24	- 20	1.1/4	- 24	1.1/2 - 11.5
CN - 24	- 24	1.1/2	- 24	1.1/2 - 11.5
CN - 24 - 20	- 24	1.1/2	- 20	1.1/4 - 11.5
CN - 24 - 32	- 24	1.1/2	- 32	2 - 11.5
CN - 32	- 32	2	- 32	2 - 11.5
CN - 32 - 24	- 32	2	- 24	1.1/2 - 11.5
CN - 32 - 40	- 32	2	- 40	2.1/2 - 8
CN - 40	- 40	2.1/2	- 40	2.1/2 - 8
CN - 40 - 32	- 40	2.1/2	- 32	2 - 11.5
CN - 40 - 48	- 40	2.1/2	- 48	3 - 8
CN - 48	- 48	3	- 48	3 - 8
CN - 64	- 64	4	- 64	4 - 8

HM

HOSE MENDER

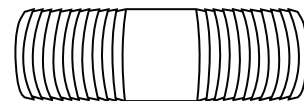

PART. REF.	HOSE / IN.		HOSE / IN.	
	SIZE	INCH	SIZE	THREAD
HM - 8	- 08	1/2	- 08	1/2
HM - 10	- 10	5/8	- 10	5/8
HM - 12	- 12	3/4	- 12	3/4
HM - 16	- 16	1	- 16	1
HM - 20	- 20	1.1/4	- 20	1.1/4
HM - 24	- 24	1.1/2	- 24	1.1/2
HM - 32	- 32	2	- 32	2
HM - 40	- 40	2.1/2	- 40	2.1/2
HM - 48	- 48	3	- 48	3

**EMBOUTS PUSH-ON
PUSH-ON INSERTS
2020**



**Le Futur, C'est maintenant...
The Future Starts Now...**

PUSH-ON SERIES**705**

FEMALE BSP
CARBON STEEL ONLY

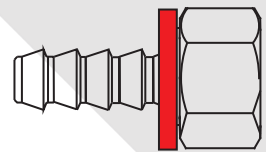

PART. REF.	HOSE STEM ID	HOSE END THREAD
705 - 44	1/4	1/4 - 19
705 - 66	3/8	3/8 - 19
705 - 88	1/2	1/2 - 14
705 - 1010	5/8	5/8 - 14
705 - 1212	3/4	3/4 - 14
705 - 1616	1	1 - 11

707

MALE BSPT
CARBON STEEL ONLY

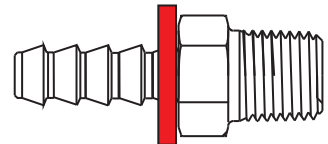

PART. REF.	HOSE STEM ID	HOSE END THREAD
707 - 44	1/4	1/4 - 19
707 - 66	3/8	3/8 - 19
707 - 68	3/8	1/2 - 14
707 - 86	1/2	3/8 - 19
707 - 88	1/2	1/2 - 14
707 - 1212	3/4	3/4 - 14
707 - 1616	1	1 - 11

715

MALE BSPP
CARBON STEEL ONLY

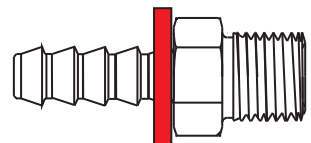

PART. REF.	HOSE STEM ID	HOSE END THREAD
715 - 44	1/4	1/4 - 19
715 - 66	3/8	3/8 - 19
715 - 88	1/2	1/2 - 14
715 - 1212	3/4	3/4 - 14
715 - 1616	1	1 - 11

725

MALE NPT
BRASS

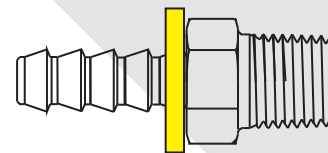

PART. REF.	HOSE STEM ID	HOSE END THREAD
725 - 4A	1/4	1/8 - 27
725 - 4B	1/4	1/4 - 18
725 - 4C	1/4	3/8 - 18
725 - 5A	5/16	1/8 - 27
725 - 5B	5/16	1/4 - 18
725 - 6A	3/8	1/8 - 27
725 - 6B	3/8	1/4 - 18
725 - 6C	3/8	3/8 - 18
725 - 6D	3/8	1/2 - 14
725 - 6E	3/8	3/4 - 14
725 - 8B	1/2	1/4 - 18
725 - 8C	1/2	3/8 - 18
725 - 8D	1/2	1/2 - 14
725 - 8E	1/2	3/4 - 14
725 - 10C	5/8	3/8 - 18
725 - 10D	5/8	1/2 - 14
725 - 10E	5/8	3/4 - 14
725 - 12D	1/2	1/2 - 14
725 - 12E	1/2	3/4 - 14

726

FEMALE NPT FIXE
BRASS

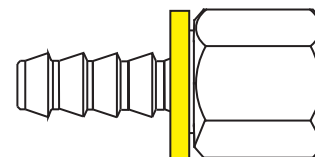

PART. REF.	HOSE STEM ID	HOSE END THREAD
726 - 4A	1/4	1/8 - 27
726 - 4B	1/4	1/4 - 18
726 - 4C	1/4	3/8 - 18
726 - 6A	3/8	1/8 - 27
726 - 6C	3/8	3/8 - 18
726 - 8C	1/2	3/8 - 18
726 - 8D	1/2	1/2 - 14
726 - 8E	1/2	3/4 - 14
726 - 12E	3/4	3/4 - 14

727

MALE SAE / 45° FLARE
BRASS

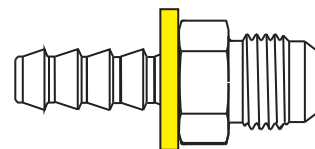

PART. REF.	HOSE STEM ID	HOSE END THREAD
727 - 44	1/4	7/16 - 20
727 - 45	1/4	1/2 - 20
727 - 66	3/8	5/8 - 18
727 - 88	1/2	3/4 - 16
727 - 1212	3/4	1.1/16 - 14

PUSH-ON SERIES

728

FEMALE SAE / 45° FLARE
BRASS

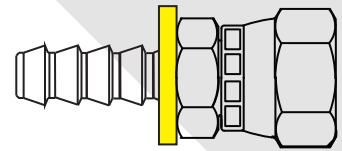

PART. REF.	HOSE STEM ID	HOSE END THREAD
728 - 44	1/4	7/16 - 20
728 - 45	1/4	1/2 - 20
728 - 56	5/16	5/8 - 18
728 - 66	3/8	5/8 - 18
728 - 68	3/8	3/4 - 16
728 - 86	1/2	5/8 - 18
728 - 88	1/2	3/4 - 16
728 - 810	1/2	7/8 - 14
728 - 108	5/8	3/4 - 16
728 - 1010	5/8	7/8 - 14
728 - 1212	3/4	1.1/16 - 14

729

HOSE MENDER
BRASS

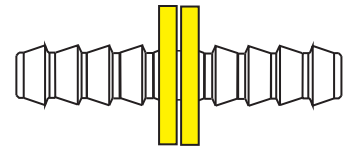

PART. REF.	HOSE STEM ID	HOSE STEM ID SECOND SIDE
729 - 4	1/4	1/4
729 - 5	5/16	5/16
729 - 6	3/8	3/8
729 - 8	1/2	1/2
729 - 10	5/8	5/8
729 - 12	3/4	3/4

732

RIGID TUBE SHANK
BRASS

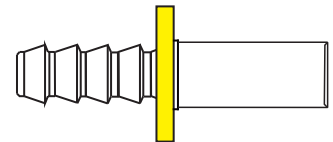

PART. REF.	HOSE STEM ID	HOSE END TUBE
732 - 88	1/2	1/4
732 - 1212	3/4	3/4

PUSH-ON SERIES

735

MALE INVERTED FLARE 45°
BRASS

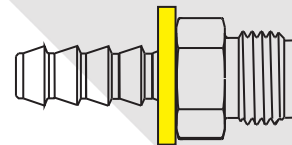

PART. REF.	HOSE STEM ID	HOSE END THREAD
735 - 43	1/4	3/8 - 24
735 - 44	1/4	7/16 - 20
735 - 45	1/4	1/2 - 20
735 - 65	3/8	1/2 - 20
735 - 66	3/8	5/8 - 18
735 - 86	1/2	5/8 - 18
735 - 88	1/2	3/4 - 16
735 - 1010	5/8	7/8 - 14

736

FEMALE INVERTED FLARE 45°
BRASS

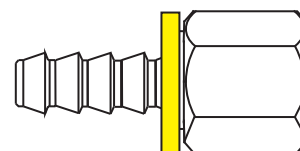

PART. REF.	HOSE STEM ID	HOSE END THREAD
736 - 43	1/4	3/8 - 24
736 - 44	1/4	7/16 - 20
736 - 45	1/4	1/2 - 20
736 - 65	3/8	1/2 - 20
736 - 66	3/8	5/8 - 18

737

MALE JIC
BRASS

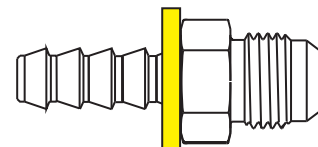

PART. REF.	HOSE STEM ID	HOSE END THREAD
737 - 44	1/4	7/16 - 20
737 - 45	1/4	1/2 - 20
737 - 46	1/4	9/16 - 18
737 - 66	3/8	9/16 - 18
737 - 88	1/2	3/4 - 16
737 - 1212	3/4	1.1/16 - 12

738

FEMALE JIC
BRASS

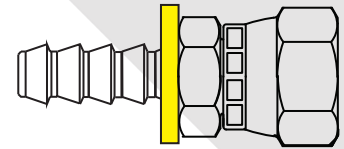

PART. REF.	HOSE STEM ID	HOSE END THREAD
738 - 44	1/4	7/16 - 20
738 - 45	1/4	1/2 - 20
738 - 55	5/16	1/2 - 20
738 - 66	3/8	9/16 - 18
738 - 88	1/2	3/4 - 16
738 - 810	1/2	7/8 - 14
738 - 108	5/8	3/4 - 16
738 - 1010	5/8	7/8 - 14
738 - 1210	3/4	7/8 - 14
738 - 1212	3/4	1.1/16 - 12
738 - 1616	1	1.5/16 - 12

739

90° ELBOW MALE NPT
BRASS

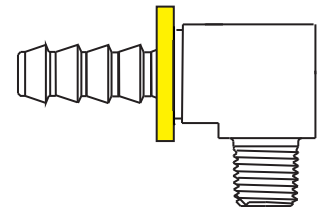

PART. REF.	HOSE STEM ID	HOSE END THREAD
739 - 4A	1/4	1/8 - 27
739 - 4B	1/4	1/4 - 18
739 - 5B	5/16	1/4 - 18
739 - 6A	3/8	1/8 - 27
739 - 6B	3/8	1/4 - 18
739 - 6C	3/8	3/8 - 18
739 - 6D	3/8	1/2 - 14
739 - 8C	1/2	3/8 - 18
739 - 8D	1/2	1/2 - 14
739 - 10D	5/8	1/2 - 14
739 - 12E	3/4	3/4 - 14

795

FEMALE BSP 90°
CARBON STEEL ONLY

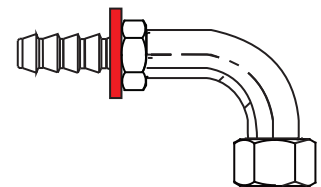

PART. REF.	HOSE STEM ID	HOSE END THREAD
795 - 44	1/4	1/4 - 19
795 - 66	3/8	3/8 - 19
795 - 88	1/2	1/2 - 14
795 - 1010	5/8	5/8 - 14
795 - 1212	3/4	3/4 - 14
795 - 1616	1	1 - 11

PUSH-ON SERIES

725SW

MALE NPT SWIVEL
BRASS

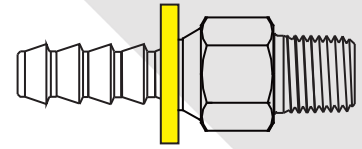

PART. REF.	HOSE STEM ID	HOSE END THREAD
725SW - 4B	1/4	1/4 - 18
725SW - 6B	3/8	1/4 - 18
725SW - 6C	3/8	3/8 - 18
725SW - 8C	1/2	3/8 - 18
725SW - 8D	1/2	1/2 - 14
725SW - 12E	3/4	3/4 - 14

also available...



ACCESSORIES

GREASE COMPONENTS

- Custom hose assembly
- Bulk hose and fittings
- Button head
- Carbon steel & Stainless Steel
- Grease gun
- Variety of threads
- NPT
- BSP
- METRIC

SUPPORT CLAMPS

- Single, Twin & HD
- Black polypropylene
- 6mm up to 219mm
- Weld, rail and stacking hardware available
- Rubber insert available
- 1 & 2 meters rail length available

CLAMPS

- Steel & stainless steel HD clamps
- Gear clamps
- Vinyl dipped clamps
- Hammer punch clamps
- Double ear clamps



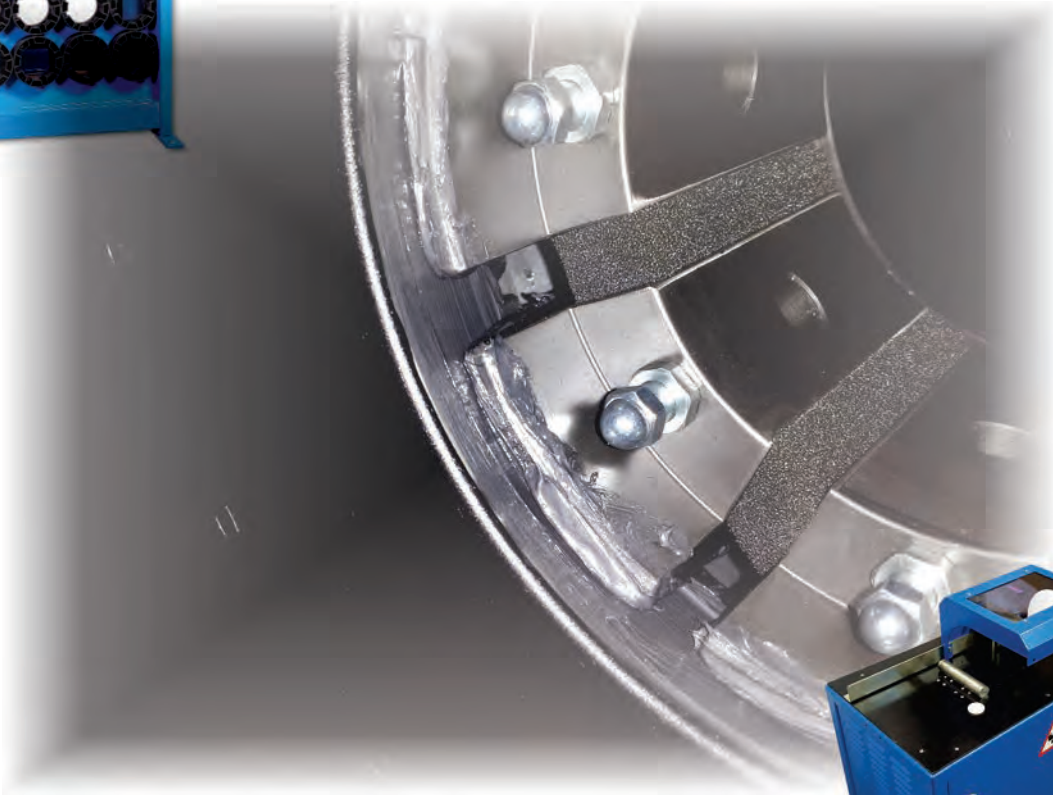

**Le Futur, C'est maintenant...
The Future Starts Now...**

D100SH/D100AP

SERVICE HOSE CRIMPERS

WEIGHING IN AT ONLY 38LBS AND MOUNTED ON A LIGHT WEIGHT TUBULAR FRAME, THIS 35 TON CRIMPER CAN BE CARRIED TO ALMOST ANY LOCATION WHERE SERVICE IS REQUIRED. THE D100 SERIES CRIMPERS ARE THE "GO ANYWHERE" CRIMPERS FOR HOSE SIZES UP TO 1".



D100-SH

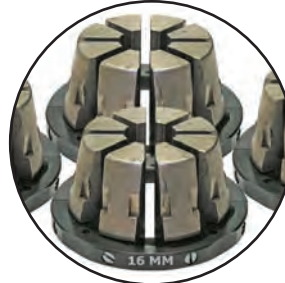

HIGH VISIBILITY: INVERTED DIE POSITION ALLOWS OPERATOR TO ACCURATELY POSITION THE FITTINGS PRIOR TO CRIMPING.



LIGHT WEIGHT PORTABLE UNIT: TRULY "PORTABLE" CRIMPER CAN BE CARRIED TO ALMOST ANY LOCATION WHERE SERVICE IS REQUIRED.



ACCURATE AND REPEATABLE: AN INFINITELY ADJUSTABLE MICROMETER AND THE MICRO SITE INDICATOR MAKE PRECISE AND REPEATABLE CRIMPS.



D100-AP

D100SH / D100AP
35 TON
2 WIRE: UP TO 1"
4SP: UP TO 3/4"
L: 12-1/2" X W: 12-1/2" X H: 24"
WEIGHT: 38LBS
D100SH POWER: HAND
D100AP POWER: AIR

D100SH / D100AP

STANDARD

OPTIONAL



D100 STANDARD DIES

PART #	CRIMP RANGE
D105-12MM	12-14MM
D105-14MM	14-16MM
D105-16MM	16-19MM
D105-19MM	19-23MM
D105-22MM	22-26MM
D105-25MM	25-29MM
D105-30MM	30-34MM
D105-34MM	34-39MM
D105-39MM	39-43MM
D105-44MM	44-48MM
D105-47MM	47-51MM

*Other die sizes are available

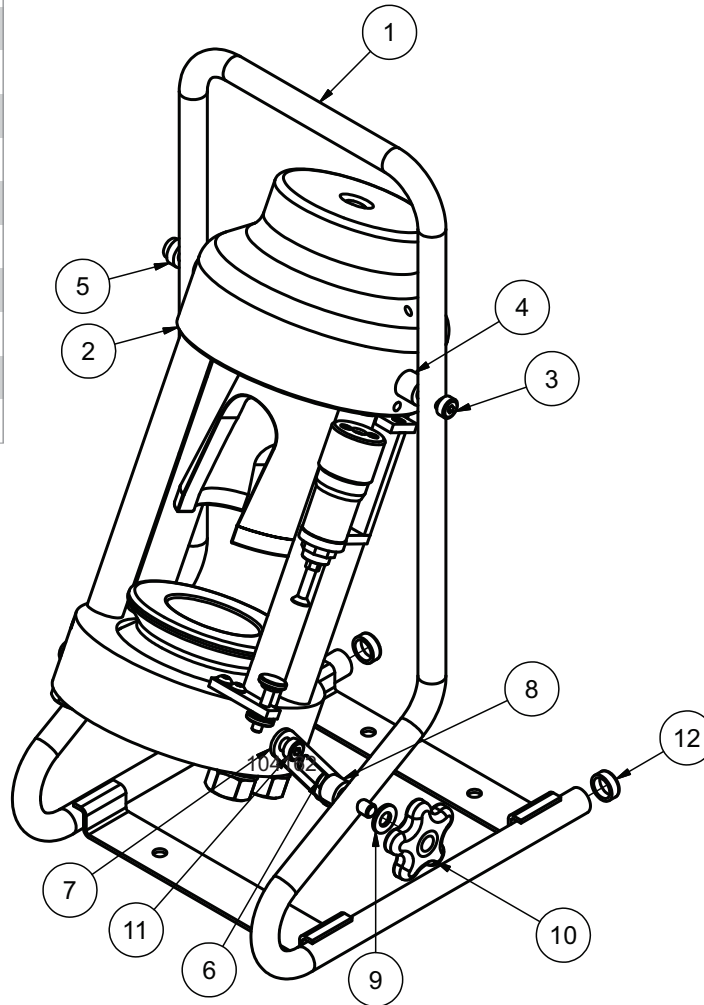

D100SH/D100AP PORTABLE CRIMPER ASSEMBLY

ITEM	PART NUMBER	DESCRIPTION	QTY
1	100905	D100 CRIMPER FRAME	1
2	100929	D100 HEAD ASSEMBLY	1
3	91259A628	3/8 X 2 SHOULDER SCREW	2
4	101040	3/8 X 3/4 X 5/8 SPACER	2
5	100956	3/8 X 3/4 X 5/8 SPACER	1
6	93548A628	3/8-16 X 2-1/2 CARRIAGE BOLT	2
7	100980	ADJUSTMENT ARM	2
8	101041	3/8 X 3/4 X 3/4 SPACER	2
9	WS23556	3/8 FLAT WASHER	2
10	DK-186	ANGLE ADJUSTMENT KNOB	2
11	91259617	3/8 X 3/8 SHOULDER SCREW	2
12	940528133	PLASTIC CAP	2
13	104162	DIE LUBRICANT	1

***IMPORTANT*
DIE LUBRICANT
13.**



DW165

SERVICE HOSE CRIMPERS

THE DW165 CRIMPER HAS THE FEATURES OF THE D105 SERIES, BUT THE MORE POWERFUL 62 TON CYLINDER GIVES IT THE CAPABILITY TO CRIMP UP TO 1-1/4" 4 WIRE HOSE WHILE STILL RETAINING THE SMALL FOOTPRINT OF THE D105 SERIES CRIMPERS.



ACCURATE AND REPEATABLE: AN INFINITELY ADJUSTABLE MICROMETER AND ELECTRONIC SHUTOFF SWITCH.



SAVE TIME: REMOVABLE FITTING STOP FOR MULTIPLE CRIMPS OF THE SAME HOSE AND FITTING.



ROUGH SERVICE: DW105 RUBBER CAGED DIES SETS FOR HEAVY DUTY ENVIRONMENTS.



DW165



***Drawer is optional**

DW165
62 TON
2 WIRE: UP TO 1-1/4"
4SP: UP TO 1-1/4"
L: 22-1/2" X W: 13" X H: 22-1/2"
WEIGHT: 154LBS (Average)
POWER: 1HP/110V/1 PHASE(STD)

DW165

STANDARD



OPTIONAL



DW165 STANDARD DIES

PART #	CRIMP RANGE
DW-105-8MM	8-12MM
DW-105-12MM	12-14MM
DW-105-14MM	14-16MM
DW-105-16MM	16-19MM
DW-105-19MM	19-23MM
DW-105-22MM	22-26MM
DW-105-25MM	25-29MM
DW-105-30MM	30-34MM
DW-105-34MM	34-39MM
DW-105-39MM	39-43MM
DW-105-44MM	44-48MM
DW-105-47MM	47-51MM

*Other die sizes are available

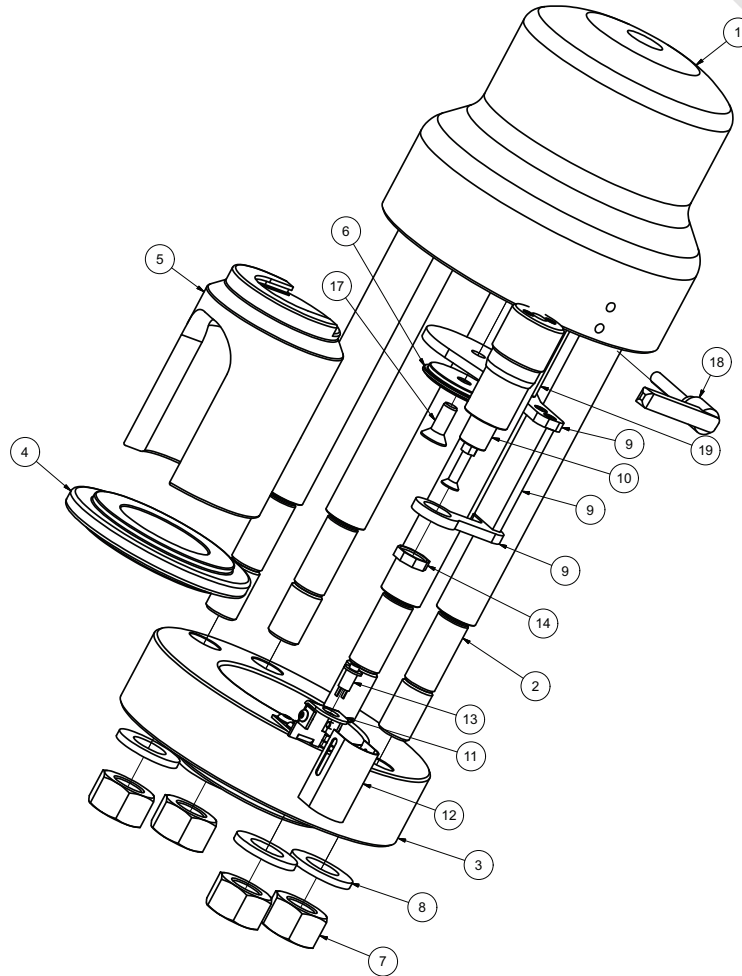

DW165 PORTABLE CRIMPER ASSEMBLY

ITEM	PART NUMBER	DESCRIPTION	QTY
1	102219	DW165 60 TON CYLINDER ASSEMBLY	1
2	102270	8 1/4" STRAIN ROD	4
3	104727	DW165 - T420 BASE FLANGE	1
4	103270	DW165 - T420 PRESS PLATE	1
5	100825	60 TON PUSHER	1
6	100812	PUSHER RETAINING PIN	1
7	90499A845	7/8-14 HEX NUT	4
8	11038	7/8 NARROW RIM WASHER	4
9	102220-T420	MICROMETER HOLDING ASSEMBLY	1
10	100628	STANDARD MICROMETER ASSEMBLY*	1
11	101092	LIMIT SWITCH BRACKET	1
12	100692	LIMIT SWITCH GUARD	1
13	903 SWITCH	RED LIMIT SWITCH	1
14	100727	MICROMETER NUT	1
18	91259617	STOP ROD LOCKING HANDLE	1
19	940528133	RETRACTION STOP ROD	1
20	104162	DIE LUBRICANT	1

***IMPORTANT*
DIE LUBRICANT
20.**



THE D205 IS A UNIQUE VERTICAL CRIMPER WITH FUNCTIONS AND FEATURES THAT ENABLE YOU TO QUICKLY AND ACCURATELY CRIMP ALL OF YOUR HOSE ASSEMBLIES UP TO 2" 6 WIRE HOSE (WITH DOUBLE ANGLE DIES). THIS POWERFUL AND VERSATILE CRIMPER IS ONE OF THE BEST VALUES ON THE MARKET.



FLEXIBILITY: DOUBLE ANGLE DIES EFFECTIVELY DOUBLE THE CRIMPING FORCE TO 160 TON.



BENT TUBE & SPECIAL FITTINGS: EASILY REMOVABLE PUSHER AND SPLIT DIES ACCOMMODATE DIFFICULT CRIMPS.

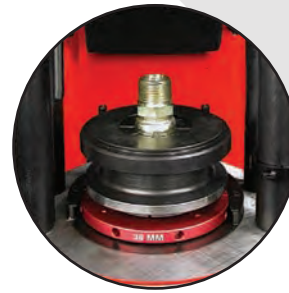

HIGH VISIBILITY: INVERTED DIE POSITION ALLOWS OPERATOR TO ACCURATELY POSITION THE FITTING PRIOR TO CRIMPING.



SAVE TIME: ADJUSTABLE RETRACTION STOP LIMITS RAM RETRACTION.



D205/D206	
80 TON SA DIES	160 TON DA DIES
1-2 WIRE: UP TO 1-1/4"	1-2 WIRE: UP TO 2"
4SP: UP TO 1-1/4"	4SP: UP TO 2"
6SP: UP TO 1-1/4"	6SP: UP TO 2"
L: 32" X W: 17" X H:29"	
WEIGHT: 305LBS (AVERAGE)	
D205: 2HP/220V/1 PHASE	
D206: 1HP/110V/1 PHASE	

D205/D206

D205/D206

STANDARD OPTIONAL



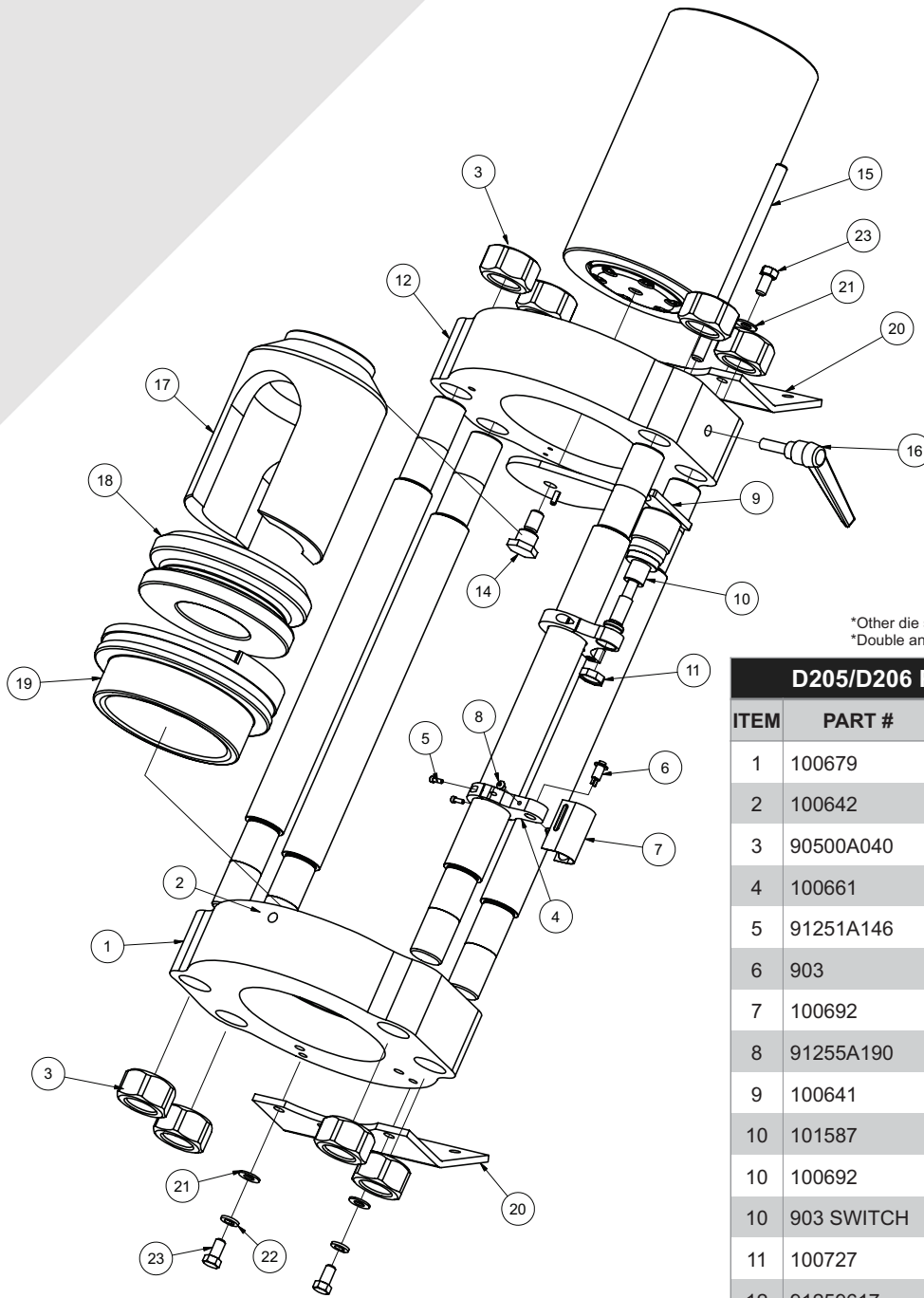

*Other die sizes are available
*Double angle die on request

D205 STANDARD DIES

PART #	CRIMP RANGE
D205-8MM	8-12MM
D205-12MM	12-14MM
D205-14MM	14-16MM
D205-16MM	16-19MM
D205-19MM	19-23MM
D205-22MM	22-26MM
D205-25MM	25-29MM
D205-30MM	30-34MM
D205-34MM	34-39MM
D205-39MM	39-43MM
D205-44MM	44-48MM
D205-47MM	47-51MM
D205-54MM	54-58MM

D205/D206 PORTABLE CRIMPER ASSEMBLY

ITEM	PART #	DESCRIPTION	QTY
1	100679	80 TON CONE BASE	1
2	100642	STRAIN ROD	4
3	90500A040	1-1/4-12 GRADE 8 HEX NUT	8
4	100661	LIMIT SWITCH BRACKET	1
5	91251A146	6-32 X 3/8 SHCS	2
6	903	LIMIT SWITCH	1
7	100692	LIMIT SWITCH GUARD	1
8	91255A190	8-32 X 1/4 BHCS	2
9	100641	MICROMETER MOUNT ASSEMBLY	1
10	101587	METRIC MICROMETER ASSEMBLY	1
10	100692	DC MICROMETER ASSEMBLY	1
10	903 SWITCH	STANDARD MICROMETER ASSEMBLY	1
11	100727	MICROMETER NUT	1
12	91259617	80 TON TOP FLANGE	1
13	100663	80-TON CYLINDER ASSEMBLY	1
14	100648	PUSHER SUSPENSION PIN	1
15	100711	STOP ROD	1
16	100710	STOP ROD LOCKING HANDLE	1
17	100818	PUSHER, 100 TON	1
18	100712	COMPRESSION RING	1
19	100713	PRESSURE PLATE	1
20	100680	80 TON ANGLE BRACKET	2
21	90126A031	3/8 FLAT WASHER	4
22	91102A031	3/8 LOCK WASHER	2
23	92865A622	3/8-16 X 3/4 HEX BOLT	4
24	104162	DIE LIBRICANT	1

IMPORTANT
DIE LUBRICANT
24.



WHAT MAKES NUVO NP16AP SERVICE MACHINES UNIQUE?

NUVO PORTABLE CRIMPING MACHINES ARE DESIGNED FOR FIELD SERVICE WHEN REPAIRS MUST BE MADE ON-SITE.

- * LIGHTWEIGHT, PORTABLE CONSTRUCTION
- * COMPACT, SMALL SIZE
- * ERGONOMIC DESIGN
- * SHORT SETTING TIMES FOR CRIMPING DIA.
- * PRECISION CONTROL DEVICE, EQUIPPED WITH SIGNAL LAMP
- * EFFICIENT, FAST PUMP
- * IMPRESSIVELY HIGH CRIMPING FORCE
- * RELIABLE CRIMPER FOR FIELD SERVICE
- * ENERPAC AIR HYDRAULIC PUMP

THE VERY LIGHT WEIGHT ALLOWS THE PORTABLE UNIT TO BE EASILY CARRIED TO ANY LOCATION.

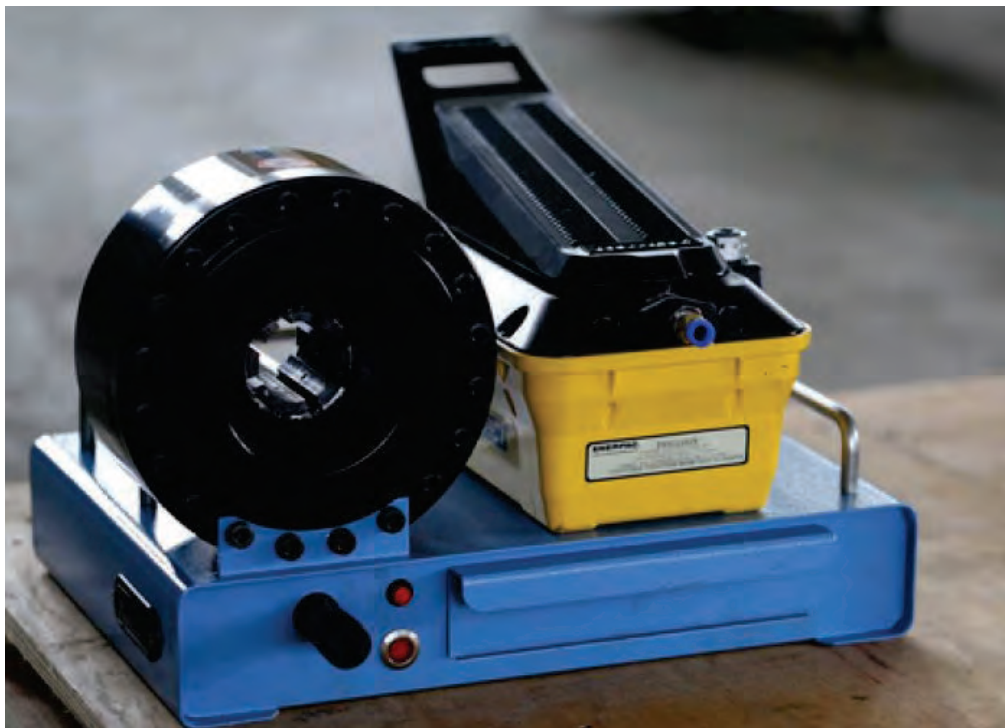

NP16AP TECHNICAL SPECIFICATION	
HOSE SIZE	1"
DIE TYPE(1)	16
MAX OPENING(mm)(2)	+20
MASTER DIE SHOE LENGTH (mm)	64
OPERATION(3)	PNEUMATIC
CRIMPING FORCE (kN)	955
DIMENSIONS	
LENGTH(mm)	337
WIDTH(mm)	402
HEIGHT(mm)	271
WEIGHT INCL. OIL(kg)	28

(1) see table for standard die set data
 (2) min. crimping dia. of die set added by table value
 (3) NP16AP operates with 725 bar.



Precision Micrometer

Enerpac® Air Hydraulic Pump



NP16AP / NP16HP

STANDARD



OPTIONAL





CRIMPERS	P32D
CRIMPING FORCE (TN)	245
MAX. HOSE DIA. 2 WIRE	2"
MAX. HOSE DIA. 4 WIRE	1-1/2"
MAX. HOSE DIA. 6 WIRE	1-1/2"
CRIMPER DEPTH	27"
CRIMPER WIDTH	24"
CRIMPER HEIGHT	55"
WEIGHT	660LBS
P32D	220V (1PH)
P32D-110*	110V (1PH)

*Available in 110V 1PH

P32D

STANDARD



Mode d'emploi
Operating Instruction

Panneau de Contrôle Numérique
Digital Control Board

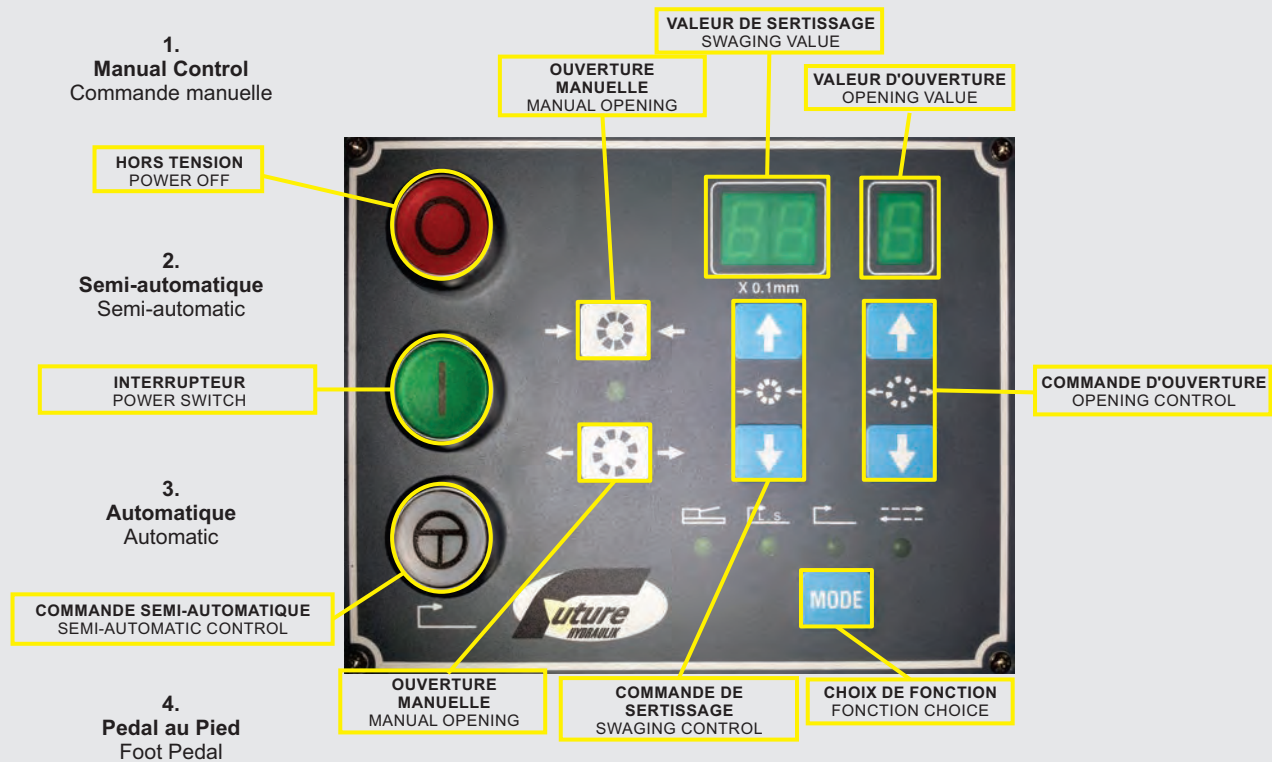



CRIMPERS	FH65
CRIMPING FORCE (TN)	240
MAX. HOSE DIA. 2 WIRE	3"
MAX. HOSE DIA. 4 WIRE	2"
MAX. HOSE DIA. 6 WIRE	2"
CRIMPER DEPTH	34"
CRIMPER WIDTH	39"
CRIMPER HEIGHT	59"
WEIGHT	2200LBS
POWER EQUIPMENT	220V (3PH)

FH65
STANDARD



CRIMPERS	FP165
CRIMPING FORCE (TN)	560
MAX. HYDRAULIC. HOSE	3"
MAX. INDUSTRIAL HOSE DIA.	6"
CRIMPER DEPTH	42"
CRIMPER WIDTH	51"
CRIMPER HEIGHT	70"
WEIGHT	6270LBS
POWER EQUIPMENT	440V (3PH)

FP165
STANDARD

OPTIONAL

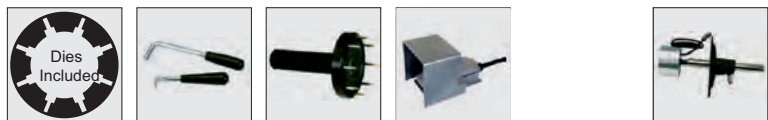



CUTM-16/4



* Cutting table can be sold separately (CUTT-16/M)

CUTTERS	CUTM-16/4
BLADE	CUTB-12V1
MAX. HOSE DIA. 2 WIRE	UP TO 1-1/2"
MAX. HOSE DIA. 4 WIRE	UP TO 1"
MAX. HOSE DIA. 6 WIRE	UP TO 1"
MOTOR	120V, 15A



CUTTING BLADES	
PART #	SHAFT ID
CUTB-7V5/8	5/8
CUTB-8V5/8	5/8
CUTB-10V3/4	3/4
CUTB-10V1	1
CUTB-12V1	1
CUTB-12V2	2
CUTB-14V1	1
CUTB-14V1-1/8	1-1/8
CUTB-14V1-1/4	1-1/4

CUTTERS	C300W
BLADE	CUTB-12V2
MAX. HOSE DIA. 2 WIRE	UP TO 2"
MAX. HOSE DIA. 4 WIRE	UP TO 1-1/4"
MAX. HOSE DIA. 6 WIRE	N/A
MOTOR	4HP
VOLTAGE SINGLE PHASE	220V/19.5A/60Hz
VELOCITY	3420 RPM
DIA. OF BLADE EXT.	12"
DIA. OF BLADE INT.	2"
SMOKE ECACUATION SYSTEM	2-1/2"
DIMENSIONS	
LENGTH	18"
WIDTH	16"
HEIGHT	17"
WEIGHT	110LBS

A MANUALLY OPERATED CUTTING MACHINE DESIGNED FOR SMALLER WORKSHOP AND SERVICE VANS. C300W HAS A ROBUST CONSTRUCTION, HIGHLY RELIABLE AND EASY TO OPERATE. THE MACHINE INCLUDES A SMOKE EVACUATION CONNECTION.



C300W



C400/C400P

CUTTERS	C400/C400P
BLADE	CUTB-12V1-1/8
MAX. HOSE DIA. 2 WIRE	UP TO 2"
MAX. HOSE DIA. 4 WIRE	UP TO 2"
MAX. HOSE DIA. 6 WIRE	UP TO 1-1/2"
MOTOR	4HP
VOLTAGE SINGLE PHASE	220V/16A/60Hz
VELOCITY	2900 RPM
DIA. OF BLADE EXT.	14"
DIA. OF BLADE INT.	1-1/8"
SMOKE ECACUATION SYSTEM	2-1/2"
DIMENSIONS	
LENGTH	17"
WIDTH	30"
HEIGHT W/ GUARD	44"
WEIGHT	295LBS

*C400P is a pneumatic cutting machine.

CUTTERS	CM75PH
BLADE	N/A
MAX. HYDRAULIC HOSE	2" 6WIRE
MAX. INDUSTRIAL HOSE	4"
MOTOR	7.4HP
VOLTAGE 3-PHASE	220V
VELOCITY	3000 RPM
DIA. OF BLADE EXT.	20"
SMOKE ECACUATION SYSTEM	4-1/2"
DIMENSIONS	
LENGTH	36"
WIDTH	26"
HEIGHT	55"
WEIGHT	560LBS



CM75PH

SKIVERS



7S1126

*Part no. 7S1120 for blade only

SKIVERS	7S1126
HOSE RANGE	3/4" TO 2"
EXTERIOR SKIVE	X

SKIVERS	W410
HOSE RANGE	3/8" TO 2"
EXTERIOR SKIVE	X
W410-37	BLADE ONLY
W410-29	3/8
W410-30	1/2
W410-51	5/8
W410-31	3/4
W410-32	1
W410-33	1-1/4
W410-55	1-1/2
W410-56	2
W410-36	HANDLE



W410

TEST BENCH

Model	PT1000	PT1800	PT3600	PT5000
PRESSURE MAX. BAR	1000	1800	3600	5000
TEST PORT	1/4 NPT			
LIGHT	OPTIONAL			
PRINTER	STANDARD			
AUTOMATIC TESTING CONTROL	STANDARD			
MANUAL PRESSURE RELEASE	STANDARD			
AUTOMATIC PRESSURE RELEASE	3/4			
WEIGHT (LBS)	1100LBS (AVERAGE)			
L*W*H IN	79*43*51			



Bundle Rack



Reel Rack



BUNDLE-RACK6	
HOSE CAPACITY	3/16" - 1-1/4"
MAX. LOAD PER REEL	1-1/4"
MAX. OUTER DIA. OF COIL	1-1/4"
MAX. INNER DIA. OF COIL	1"
MAX. HEIGHT OF COIL	14"
COLOR	PLATED GREY
DIMENSION	-----
WIDTH	48"
HEIGHT	79"
DEPTH	48"
WEIGHT	330 LBS

SUPCG-3	
MAX. REEL	12
COLOR	PLATED GREY
DIMENSION	-----
WIDTH	52"
HEIGHT	104"
DEPTH	52"
WEIGHT	N/A

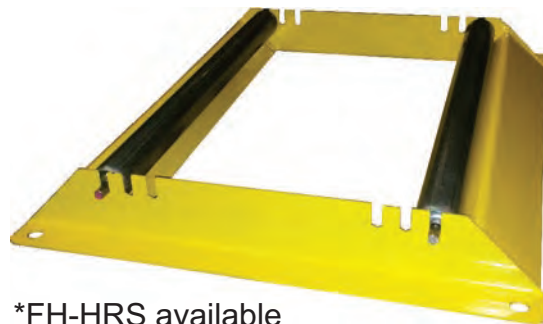

*FH-HRS available

also available...



ADAPTERS

SAE ADAPTER SERIES

- Over 4000 SKUs
- Bulkhead adapters
- Straight, 45°, 90° Adapters
- Multiple combination of threads
- NPT/JIC/ORB/ORFS
- 1/8" to 3" available
- Tube weld adapters
- Blank and Restrictor adapters

BSP METRIC

- Over 3000 SKUs
- Bulkhead adapters
- Straight, 45°, 90° Adapters
- Multiple combination of threads
- BSPT/BSPP/METRIC/JIS/KOMATSU/
- 1/8" to 3" available

DIN METRIC

- Over 2000 SKUs
- Bulkhead adapters
- Straight, 45°, 90° Adapters
- Multiple combination of threads
- Extra Light/Light/Heavy
- 1/8" to 3" available

FLANGE

- Over 300 SKUs
- Extreme performance
- Straight, 45°, 90° Adapters
- Multiple combination of threads
- C61/C62/JIC/ORFS/ORB
- Forged & Tube Style available
- 1/2" to 4" available



**Index Numérique / Numerical Index
BOYAUX, RACCORDS & ÉQUIPEMENT
HOSE, COUPLINGS & EQUIPMENT**

2020

No. de Pièces Part No.	Page(s)	No. de Pièces Part No.	Page(s)	No. de Pièces Part No.	Page(s)	No. de Pièces Part No.	Page(s)	No. de Pièces Part No.	Page(s)
05125		A/B-11210		A/B-22712		C-14110		C-23811	
05126		A/B-11310		A-22810		C-14190		C-23891	
05128		A/B-11710		A/B-22812		C-14310		C-23911	
05205		A/B-11810		A/B-22814		C-14390		C-23921	
05209		A/B-11813		A/B-23311		C-20310		C-23931	
05225/05235		A/B-12410		A/B-23321		C-20612/13		C-23941	
05226		A/B-12510		A/B-23331		C-20712/812		C-23961	
05245		A/B-12610		A/B-23341		C-20742/842		C-23971	
05291		A/B-12810		A/B-23361		C-20792/892		C-23991	
05294		A/B-12910		A/B-23371		C-20882		C-24011	
31125		A/B-12940		A/B-23391		C-20910/L		C-24041	
31128		A/B-12990		A/B-23611		C-21512		C-24091	
31158		A/B-12H10		A/B-23641		C-21542		C-24111	
31205		A/B-12H40		A/B-23691		C-21592		C-24141	
31209		A/B-12H90		A/B-23811		C-21612		C-24191	
31224		A/B-13010		A/B-23891		C-21642		C-24493	
31225		A/B-14110		A/B-23911		C-21692		C-24792	
31291		A/B-14190		A/B-23941		C-21713		C-24913	
32125		A/B-14310		A/B-23991		C-21813			
32128		A/B-14390		A/B-24011/12		C-21893		C300W	
32205		A-14913		A/B-24041		C-22010		C400/C400P	
32209		A/B-20310		A/B-24091		C-22040		CM75PH	
32224		A/B-20612/13		A/B-24111		C-22090		CN	
32225		A/B-20812		A/B-24141		C-22411/13		CUTM-16/4	
32226		A/B-20842		A/B-24191		C-22441/43		CUTT-16/M	
32291		A/B-20882F		A/B-24493		C-22491/93		CUTT. BLADES	
3903-02102		A/B-20892		A/B-24792		C-22541		D100SH/AP	
3903-02142		A/B-20910/L		A/B-24913		C-22542/743		D205/D206	
3903-02543		A/B-21512/13/LL		BENCH TEST		C-22582		DW165	
3903-02544		A/B-21542/43		BRAKE		C-22591		FH65	
705		A/B-21592/93		BUNDLE RACK		C-22592/792		FP165	
707		A/B-21612/13		C-10050		C-22612		FS/VFS	
715		A/B-21642/43		C-10510		C-22642		GAUNTLET	
725		A/B-21692/93		C-10610		C-22692		HM	
725SW		A/B-21713		C-10710		C-22711		HORIZON	
726		A/B-21813		C-11110		C-22712		J20R3	
727		A/B-21893		C-11210		C-22812		J30R7	
728		A/B-22010		C-11310		C-22814		N4	
729		A/B-22040		C-11710		C-23311		N5	
732		A/B-22090		C-11810		C-23321		N5HT	
735		A/B-22411/13		C-11813		C-23331		NAG	
736		A/B-22441/43		C-12410		C-23341		NF2HT	
737		A/B-22491/93		C-12510		C-23361		NF4SH	
738		A/B-22541		C-12610		C-23371		NF5	
739		A/B-22542		C-12810		C-23391		NF6	
795		A/B-22582		C-12910		C-23611		NFFS	
7S1126		A/B-22591		C-12940		C-23621		NFJACK	
A/B-10050		A/B-22592		C-12990		C-23631		NFPILOT	
A/B-10510		A/B-22612		C-12H10		C-23641		NFPW1	
A/B-10610		A/B-22642		C-12H40		C-23661		NFPW2	
A/B-10710		A/B-22692		C-12H90		C-23671		NFR18	
A/B-11110		A/B-22711		C-13010		C-23691		NFR18T	

Continue/Continued...

Distributed by:

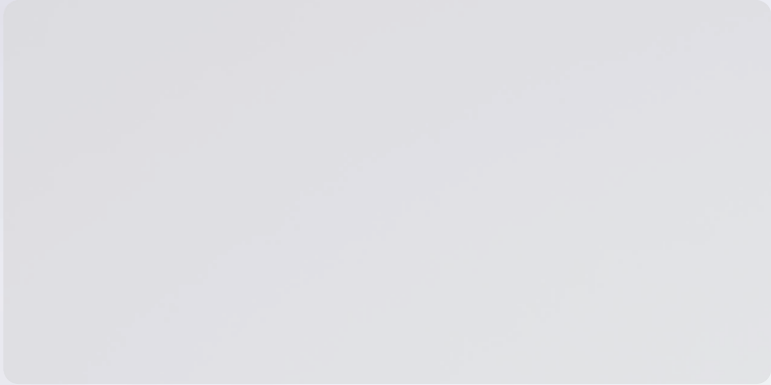

HOSE & FITTING

