

zip **SERIES**

 **MGI**™

zip *x3*

User Manual

VERSION 3.0

Contents

Thank you for purchasing the Game Changing MGI Zip X3. To get the most out of your Zip X3 please follow these quick steps before use.

- Register your Zip X3 online (section 1.0)
- Assembling the Zip X3 (section 3.0)
- Charge the battery (section 4.0)

For Customer Support, please contact MGI directly for immediate and professional advice.

www.mgigolf.com

MGI AUSTRALIA

Service Email: customerservice@mgigolf.com

Live Chat: visit www.mgigolf.com

Toll Free within Australia: 1300 644 523 (excludes mobiles)

Western Australia/ Internal phone +61 3 8872 6700

Local Service Centres: visit www.mgigolf.com

to locate you local service centre.

MGI USA

Service Email: serviceusa@mgigolf.com

Live Chat: visit www.mgigolf.com

Telephone: 1800 617 2990

Servicing Enquiries Telephone: 1888 391 0200

MGI GLOBAL

Sales Email: globalsales@mgigolf.com

Service Email: customerservice@mgigolf.com

Live Chat: visit www.mgigolf.com

NOTE: This user manual was correct at time of printing. The online version is the most up-to-date and must be referred to as the correct version. To download the most current user manual please visit www.mgigolf.com. Images shown throughout this manual may not be of the particular model you have purchased.

1.0 Registration	04
2.0 What Is Included	04
3.0 Assembling the Zip X3	05
3.1 Attaching the Rear Wheels	05
3.2 Rear Wheel Positions	06
3.3 Unfolding	07
3.4 Folding	08
3.5 Fourth Foldable Rear Wheel	09
3.6 GPS Holder and Top Handle Compartment	09
3.7 Inverting Rear Wheels	09
4.0 Battery Charging & Connection	10
4.1 Initial Charge	10
4.2 Connecting the Battery onto the Zip X3	10
4.3 Charging the Battery after Use	11
5.0 Fitting the Golf Bag	11
6.0 Front Wheel	12
7.0 Operating the Digital Top Box	12
7.1 Top Box Display	12
7.2 Start / Stop the Zip X3	13
7.3 Turn the Zip X3 Off	13
7.4 Battery Level Indicator	14
7.5 Unit Measurements	14
7.6 Distances Modes	14
7.7 Control Distance Function	14
7.8 Competition Mode	16
8.0 Adjusting and Aligning the Front Wheel	17
9.0 Warranty	18
9.1 Warranty Policy	18
9.2 Warranty Exclusions	18
9.3 Parts Installed During Warranty	18
10.0 Preventative Maintenance Program	19
10.1 Cleaning Your Zip X3	19
10.2 Rear Wheel Axles Maintenance	19
10.3 Upper and Lower Bag Strap	19
10.4 MGI Service Schedule	19
10.5 Service Record	21
11.0 Service and Repair Centres	22
12.0 Purchasing Parts and Accessories	22
13.0 Contacting MGI	22
14.0 Contacting Local Agent	23
15.0 Frequently Asked Questions	23

I.O Registration

It is most important you register your MGI Zip X3 online immediately as registration:

- Records your Zip X3 for warranty purposes
- Speeds up any servicing required on your Zip X3
- Assist us to contact you with any updates to your Zip X3

To register your Zip X3, visit www.mgigolf.com

You will need to record your MGI serial number. This is found on the Zip X3 battery base or in the top box compartment.

Please keep this user manual on file for your own reference and a copy of your serial number;

My MGI Zip X3 Serial Number is

(example AZX3V1173401234)

Purchased Date

 / /

You may be required to show proof of purchase so we recommend you keep your receipt with this manual.

2.0 What`s Included

- MGI Zip X3
- 24v Lithium Battery
- Battery Charger
- GPS Holder
- MGI Pouch with:
 - User Manual
 - Accessory Guide

3.0 Assembling Your Zip X3

3.1 Attaching the Rear Wheels

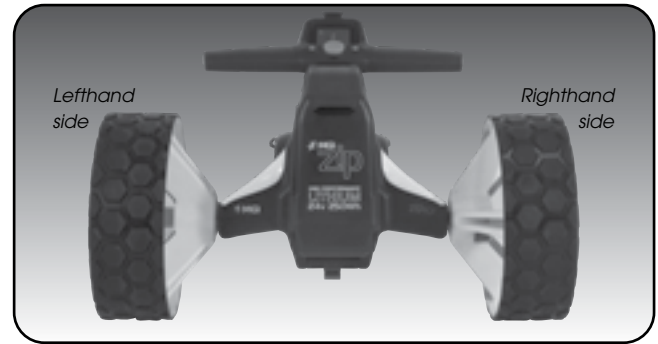

Step 1. Each wheel is labelled with L or R for left or right. This is very important as the wheels must be placed on the correct side of the Zip X3. Left or right sides are determined when standing behind the Zip X3 as pictured below.

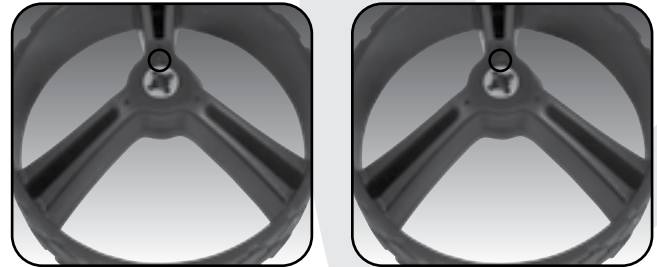

Step 2. On the wheel, press the grey release button on the wheel hub. Place the wheel onto the axle. You will notice you need to match up the inner female groove on the axle and the male of the wheel. When placed in position simply release the button. You will notice you hear a "click" when the wheel is properly secured. To check that the wheel is properly in position pull on the wheel. If it is properly in position it will not slide off. Repeat for the other wheel.

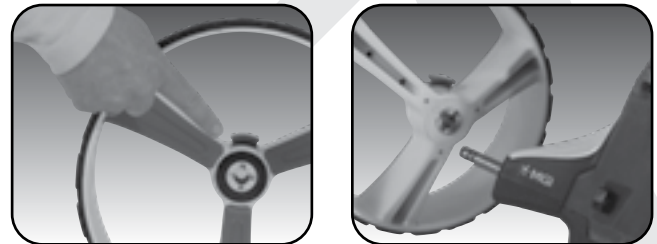

3.2 Rear Wheels Positions

The MGI Zip X3 is designed to allow the rear wheels to be in two positions. The position is determined by where the wheel is locked on the axle in either of the two grooves (see picture). The drive position is used during the normal operation of the Zip X3. The free wheel position is used to freely push the Zip X3 should you experience battery or Zip X3 issues on the course.

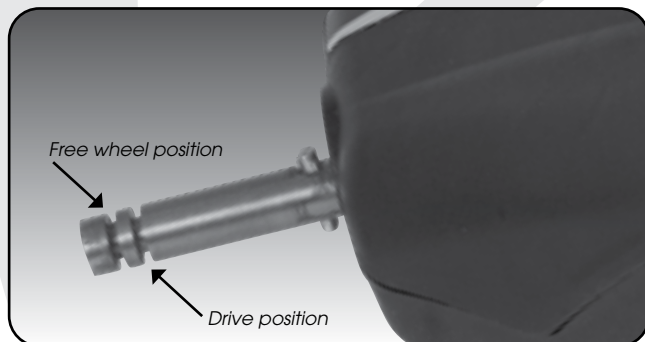

i. Drive position – Lock the wheel onto the groove closest to the battery base. To do this, press the grey release button on the wheel hub, push the wheel on to the axle as far as possible. To test for drive position try rolling the wheel backwards. If you feel resistance then the wheel is now in drive position and ready to use. Repeat for both wheels.

ii. Free wheel – Lock the wheel into the groove closest to the end of the axle. To do this, press the grey release button on the wheel hub, push the wheel on to the axle and release the release button onto the groove. To test for free wheel position try rolling the wheel backwards. The wheel should spin freely with no resistance. Repeat for both wheels.

3.3 Unfolding

Please see below the steps to unfold a Zip X3 Handle.

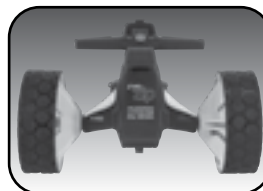

Step 1: Ensure both rear wheels are attached.



Step 2: Release Fold Lever.

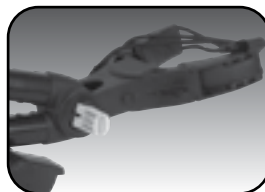

Step 3: Move Top Bag Support away from front wheel assembly until you hear it click.



Step 4: The handle is now free to pull upwards. The handle will naturally unfold as you continue to pull until the handle is completely open.



Step 5: Ensure that the latch at the bottom of the handle clicks into place.



Step 6: Close the fold lever to lock the handle into place in one of three positions.

Step 7: Push the top bag support down to move it into position.

3.4 Folding



Step 1: Disconnect the battery by lifting the battery handle. It can be left on or removed from the Zip X3.



Step 2: Open the fold lever to release the handle.



Step 3: Pull up the latch at the bottom of the handle.



Step 4: Lower the handle down flat.

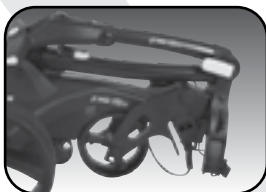

Step 5: Push the toggle down on the top bag support and then move the Top Bag Support down so that it locks over the front wheel assembly.



Step 6: Close the fold lever to lock the handle into place.

3.5 Fourth Foldable Rear Wheel

The MGI Zip X3 comes standard with a fourth foldable rear wheel. This wheel **MUST** be unfolded into position at all times when the Zip X3 is in use. This will reduce damaging the Zip X3, and provide the ultimate in stability across all terrains. This fourth wheel should be cleaned regularly with a cloth to ensure it can be folded as required for storage.



3.6 GPS Holder and Top Handle Compartment

In the top handle compartment there is a position for a GPS/mobile device holder. Open the compartment and connect the holder into position. To open the holder always press the button at the top of the holder. Place the GPS into the cradle, then close the holder by squeezing the two sides closer together.

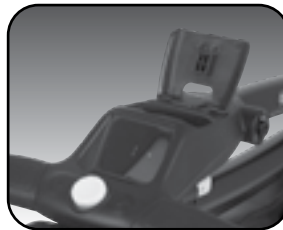

3.7 Inverting Rear wheels

The rear wheels can be inverted on the axle to reduce the size of the Zip X3 when folded. To invert the rear wheels, press the grey release button on the wheels hub and remove from the axle. Invert the rear wheels so that the wheels hub protrudes away from the axles. Press the grey release button on the wheels hub and release once the wheel is fitted onto the axle.



4.0 Battery Charging & Connection

The Zip X3 is designed to take either Zip battery:

- MGI 24v 250Wh Lithium battery (Standard)
- MGI 24v 380Wh Lithium battery (Optional)

4.1 Initial Charge

- Before using your MGI Zip X3 for the first time you must fully charge the battery overnight.
- Plug the charger AC lead into a power point - the Green LED illuminates to indicate the charger is power on.
- Plug the charger output connection into the connector on the front of the battery - the Red LED illuminates to indicate charging.
- When the charging LED indicator has turned green, the battery is fully charged and ready to be used.



Please refer to the battery charger user manual for further information.

4.2 Connecting the Battery onto the Zip X3

Position the battery on the Zip X3 and push the battery down to secure it.

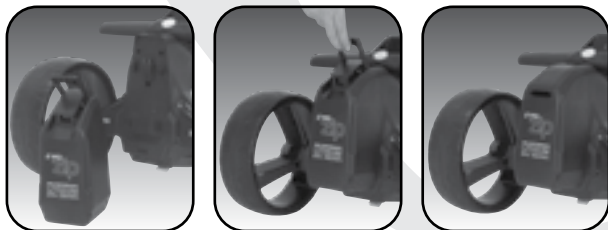

Push the handle down to connect the battery to the Zip X3.

Your Zip X3 has been equipped with fail safe battery connection, so the Zip X3 will not move when you connect the battery. Your Zip X3 will only start once the speed control is switched on.

4.3 Charging the Battery after Use

- Disconnect the battery by lifting the handle.
- The battery can be left on or removed from the Zip X3 for charging.
- Plug the charger AC lead into a power point - the Green LED illuminates to indicate the charger is power on.
- Plug the charger output connection into the connector on the front of the battery - the Red LED illuminates to indicate charging.
- When the charging LED indicator has turned green, the battery is fully charged and ready to be used.

5.0 Fitting the Golf Bag

Ensure that the top bag support straps are disconnected. Position the golf bag on the Zip X3.

Secure the top bag support strap

- Select a good position for the elasticised straps to be put around the golf bag
- Stretch the longer end of the strap and loop the rounded plastic bar underneath the hook on the shorter end
- The top bag support straps should now be connected.

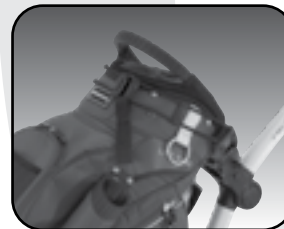

Please ensure the top bag support straps are hooked in place securely before releasing. Failure to do so could result in injury to the user.

Adjusting the length of the top bag support strap

The rounded plastic bar on the longer strap can be adjusted to ensure the bag is secured properly in place.

Secure the lower bag strap

Pull the lower bag strap over the base of the golf bag

6.0 Front Wheel

Unlocking & Locking the Front Wheel

The front swivel wheel can be set in two positions.

1) Unlocked position to allow for 360° swivel for optimum turning ability. Move the knob, on top of the front wheel assembly, to the left hand side.



2) Locked position is best when using the Controlled Distance function. Move the knob, on top of the front wheel assembly, to the right hand side.



7.0 Operating the Digital Top Box

7.1 Top Box Display

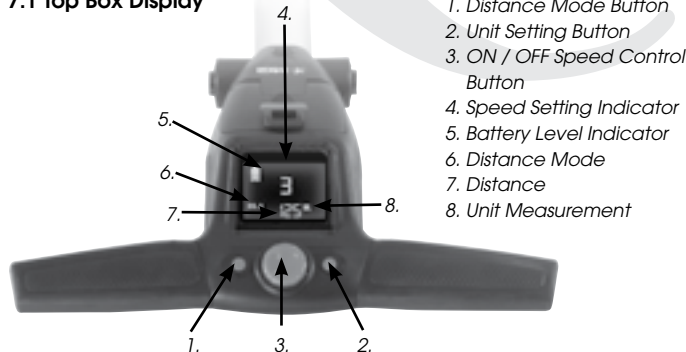

1. Distance Mode Button
2. Unit Setting Button
3. ON / OFF Speed Control Button
4. Speed Setting Indicator
5. Battery Level Indicator
6. Distance Mode
7. Distance
8. Unit Measurement

7.2 Start / Stop the Zip X3



Zip X3 Speed Control

Please note the following points regarding the Zip X3 Speed Control.

1. To select the desired speed, rotate the speed control button. Turning the speed control button clockwise will increase the speed, whilst anti-clockwise will decrease speed.
2. The speed setting chosen is displayed in the centre of the coloured screen.

Please note you will feel notches as you rotate the speed control. The notches do not indicate a change in speed. The speed will only increase or decrease as the number changes in the display.

3. To start the Zip X3 at this desired speed, tap the top of the speed control button.
4. Another tap will stop the Zip X3.
5. The desired speed can be altered up or down while the Zip X3 is moving.

7.3 Turn the Zip X3 Off

Zip X3 Battery

Please note the following points regarding the Zip X3 Battery.

Connecting the Battery onto the Zip X3

1. Position the battery on the Zip X3 and push the battery down to secure it. Push the battery handle down to connect the battery to the Zip X3.
2. To turn the Zip X3 Top Box Display off: Hold down the Start/Stop Speed Control Button and Left Hand Distance Mode Button for four seconds and the display will turn off thereby disabling the Top Box.

Please note that the battery will still be connected to the Zip X3 and will continue to drain whilst connected.

3. Please note that the Zip X3 display will also turn off if the Speed Control is not operated for 30 minutes.

Once again, please note that the battery will still be connected to the Zip X3 and will continue to drain whilst connected.

4. To reactivate the Top Box Display, whilst the battery is connected, hold down the Start/Stop Speed Control Button and Left Hand Distance Mode Button for four seconds and the display will turn on thereby enabling the Top Box.

- To fully shut down the Zip X3 and prevent the battery from discharging, disconnect the battery by lifting its handle. The battery can be left on or removed from the Zip X3.

7.4 Battery Level Indicator

Battery indication is located on the left side of the top box screen. Four coloured bars are highlighted showing full charge. The lesser number of bars displayed, means there is less battery life available. You should always check the battery status before you play golf to ensure the four bars are there.

7.5 Unit Measurements

You can move from meters / kilometres to yards / miles simply by pressing the Unit Setting Button (on the right).

7.6 Distance Modes

There are three distance measurement modes. To move between the modes by pressing the Distance Mode Button (DM) (on the left)

Distance A and B: resettable distance measurements could be used to measure how far you hit your shot and to measure how far you have walked for the day. To reset, simply press the DM Button (left side) for 3 seconds until the reading displays "0".
Distance Total: cannot be reset as it is the Odometer for the life of the Zip X3. This feature will assist with service reminders which are recommended at each 500kms (310 miles) or 6 months periods.

7.7 Control Distance Function

The Control Distance Function enables the MGI Zip X3 to be sent a preset distance before the Zip X3 auto stops. To use this function:



It is recommended that you lock the front wheel to ensure the Zip X3 tracks in a straight line.

Press and hold down Speed control button for 3-4 seconds until the speed setting changes to 5 (metres or yards) and "ADC MODE" will appear.

Turn the Speed control button clockwise to increase the distance or anti-clockwise to decrease the distance until the desired distance is achieved between 5-60 (metres or yards).

Always look ahead and assess the condition of the terrain of where you want to send the Zip X3 prior to doing so.

Once the desired distance is reached, press the Speed control button once to send the Zip X3 off to the desired distance.

7.8 Competition Mode

In the unlikely event the club you are playing at does not allow the use of distance devices you will need to disable the distances feature on the MGI Zip X3.

To disable the distance recording feature, simply hold down the left and right buttons at the same time for 3 seconds and "COMP MODE" will appear on the screen.

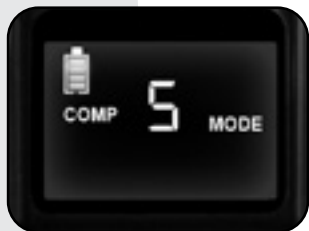

In addition, the distance recording will be removed from the screen.

To exit COMP MODE hold down the left and right buttons at the same time.

8.0 Adjusting and Aligning the Front Wheel

Each Zip X3 is checked for straight tracking prior to leaving the factory. In the unlikely event the Zip X3 is not tracking straight, the front wheel can be adjusted to regain straight tracking as follows:

1. Lock the swivelling front wheel (6.0) and run the Zip X3 forward to see if the Zip X3 veers left or right.
2. Unlock the swivelling front wheel, swivel it to see the locking latch in the middle of the two front wheels, as below Picture on Left
3. Unlock the latch by pulling down
4. Adjust the direction by turning the thumb screws in the right hand Picture. Alternate between cogs when adjusting - suggest a quarter of a turn at a time
 - To make the Zip X3 go Right - L/H screw anticlockwise, R/H screw clockwise - (Up on both sides)
 - To make the Zip X3 go Left - L/H screw clockwise, R/H screw anticlockwise - (Down on both sides)
5. Lock the latch by pushing it up.

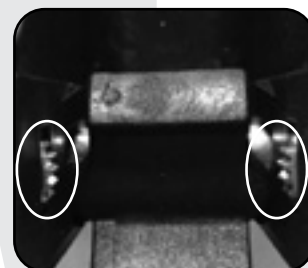
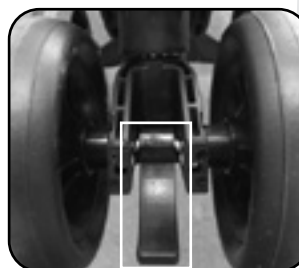

Please note that there is a process in adjusting the tracking. It is suggested that the users should do a little bit of adjustment, test the tracking and then adjust again until the Zip X3 goes straight.

9.0 Warranty

9.1 Warranty Policy

The MGI Zip X3 is covered by a limited 2 year manufacturer's warranty from the date of purchase. Duration of this warranty is:

- 2 years on parts*
- 2 years on Lithium batteries and chargers

*MGI or an authorised service centre will repair or replace any parts found to be defective in materials or workmanship under normal use provided that:

1. The MGI Zip X3 has been properly used, maintained and regularly serviced (see section 10.5)
2. The replacement or repair is performed by an authorised MGI service centre or the owner with MGI approval.
3. The Zip X3 has been registered online.

9.2 Warranty Exclusions

The following events will void warranty:

- Any alteration performed by non-authorised people or companies.
- Fitting of parts or accessories not recommended by MGI.
- Any damage caused by continued operation of the Zip X3 after it is known to be defective.
- Damage to seat and/or seat support bracket.
- Damage caused by ingress of water into motor/gearbox and other major components.
- Damage caused by the Zip X3 going into bunkers and other course hazards.
- All implied warranties (save those preserved by statute) are excluded. Liability for consequential damages under any and all warranties are excluded to the extent exclusion is permitted by law.

9.3 Parts Installed During Warranty

Warranty coverage for components installed during a motorised Zip X3's warranty period shall consist of the duration of the Zip X3's warranty period, provided the warranty installation is performed by MGI, an authorised service centre or the Zip X3 owner on approval. Replacement of parts under warranty will not extend the warranty of the Zip X3 or parts.

10.0 Preventative Maintenance Program

To properly provide for the continued operation of your MGI Zip X3, MGI has introduced its Preventative Maintenance Program (PMP). The PMP consists of work to be carried out by both the owner and authorised service centres. To properly maintain the warranty of your MGI Zip X3, it is essential that this work is carried out. If the work carried out by the authorised service centre is to replace parts that are part of the maintenance schedule, the owner will be charged for the parts and labour. If the work to be carried out is part of warranty, MGI will bear the cost.

10.1 Cleaning Your Zip X3 (See Maintenance Schedule)

- For years of good operation, your Zip X3 requires care and attention.
- Keep your Zip X3 clean by using a cloth with warm water and a mild detergent.
- Do not hose down your Zip X3 under any circumstance, as the Zip X3 has electronic components.
- Ensure that the seat stem bracket is free from sand.
- Do not submerge your Zip X3 in water as it will cause irreparable damage.
- Clean the Zip X3 battery base when the battery is removed from the Zip X3.

10.2 Rear Wheel Axles Maintenance (See Maintenance Schedule)

The rear wheel stub axles need to be lubricated regularly. Remove the rear wheels by depressing the spring clip and at the same time pull off the wheel. Apply Petroleum Jelly or light grease to the stub axles. Use a very small amount as the grease can attract sand. If you play in sandy conditions you should clean the axle and regrease fortnightly.

10.3 Upper and Lower Bag Strap Maintenance (See Maintenance Schedule)

The bag straps should be replaced as per the Service Schedule. The upper bag strap can be replaced by:

- Removing the left and right hand straps from the upper bag support
- Undo and remove the screws holding the strap in position on the bag support
- Remove and replace both bag straps
- Insert bag strap securing screws.

10.4 MGI Service Schedule

It is the owner's responsibility to ensure that all periodical checks, necessary adjustments and services are carried out. If in doubt please contact the MGI service centre:

Australia 1300 644 523

USA 1800 617 2990

Any work performed on your buggy should be recorded on your service record (see page 21) regardless of the work.

MGI Zip X3	Monthly	6 Monthly	Every 2 yrs	Every 3 yrs
Wipe down the Zip X3 with a warm cloth after each use (do not hose)	BO			
Lubricate rear wheel stub axles	BO			
Check and tighten nuts and bolts		BO		
Check and tighten handle pivots		BO		
Check alignment of Zip X3 - ensure that it runs straight		BO		
Replace Speed Controller and On/Off switch assembly				BO /SC
Replace rear and front wheels				BO
Replace upper and lower bag straps				BO

BO = Zip X3 owner can carry out this work

SC = Charged work to be carried by approved service centre

BO/SC = The six monthly service can be completed by either an authorised service centre or the owner of the Zip X3.

10.5 Service Record

6 month inspection	Date: Invoice #:	Serviced by: Signature:
1 year inspection	Date: Invoice #:	Serviced by: Signature:
1 ½ year inspection	Date: Invoice #:	Serviced by: Signature:
2 year inspection	Date: Invoice #:	Serviced by: Signature:
2 ½ year inspection	Date: Invoice #:	Serviced by: Signature:
3 year inspection	Date: Invoice #:	Serviced by: Signature:
3 ½ year inspection	Date: Invoice #:	Serviced by: Signature:
4 year inspection	Date: Invoice #:	Serviced by: Signature:
4 ½ year inspection	Date: Invoice #:	Serviced by: Signature:
5 year inspection	Date: Invoice #:	Serviced by: Signature:
5 ½ year inspection	Date: Invoice #:	Serviced by: Signature:
6 year inspection	Date: Invoice #:	Serviced by: Signature:

11.0 Service and Repair Centres

For all servicing, please do not go back to your place of purchase.

To find your nearest Service centre visit www.mgigolf.com

For warranty repairs to be authorised you MUST provide proof of purchase. Please keep this with you as well as your Serial number you can record in this manual. It is most important you register your MGI Zip X3 online for warranty purposes.

It is most important you register your MGI Zip X3 online for warranty purposes.

12.0 Purchasing Parts and Accessories

You are welcome to service your Zip X3 out of warranty, by purchasing parts direct from MGI. Please call or email to discuss the right parts and instructions.

13.0 Contacting MGI

www.mgigolf.com

MGI AUSTRALIA

Service Email: customerservice@mgigolf.com

Live Chat: visit www.mgigolf.com

Toll Free within Australia: 1300 644 523 (excludes mobiles)

Western Australia/ Internal phone +61 3 8872 6700

Local Service Centres: visit www.mgigolf.com

to locate you local service centre.

MGI USA

Service Email: serviceusa@mgigolf.com

Live Chat: visit www.mgigolf.com

Telephone: 1800 617 2990

Servicing Enquiries Telephone: 1888 391 0200

MGI GLOBAL

Sales Email: globalsales@mgigolf.com

Service Email: customerservice@mgigolf.com

Live Chat: visit www.mgigolf.com

14.0 Contacting Local Agent

Please refer to www.mgigolf.com to find the distributor in your country.

15.0 FAQ

Q: My Zip X3 is not tracking straight.

A: You can do a simple realignment on the two front wheels. See section 5.2 Adjusting and aligning the front wheels.

Q: I would like to have my MGI Zip X3 serviced. Who do I call?

A: MGI AUSTRALIA

Visit www.mgigolf.com to find your nearest service centre using your postcode within Australian and New Zealand.

You can also call MGI Head office using any of the contact details. See Section 13.0 for details. Internationals please call your local agent as per Section 14.0

MGI USA

Call 1800 617 2990

For Servicing Enquiries Telephone: 1888 391 0200

Email: serviceusa@mgigolf.com

MGI GLOBAL

Email: customerservice@mgigolf.com

zip SERIES



www.mgigolf.com

MGI AUSTRALIA
MGI HEAD OFFICE

11 Maurice Court Nunawading 3131
Victoria Australia

T +61 3 8872 6700 **E** sales@mgigolf.com

SERVICE customerservice@mgigolf.com

MGI USA

T 1800 617 2990 **E** salesusa@mgigolf.com

SERVICE 1888 391 0200 **SERVICE** serviceusa@mgigolf.com

MGI GLOBAL

E globalsales@mgigolf.com

Follow us on



Absolute attention has been taken to ensure this manual is correct at time of printing. Specifications, images and statistics may change at any time.

Visit www.mgigolf.com for the most current model information. Version 3.0