



Renaissance Cooking Systems Product Warranty

RCS is proud to provide the industries most comprehensive warranty program.

All RCS refrigeration and sink products are warranted to be free from manufacturer defects for 5 years to the original owner.

For service assistance, please reach out to us at the email address below. You may also check our website for lots of great information on using, servicing, or cooking on your new RCS grill.

This warranty excludes normal surface corrosion, discoloration, surface scratches and surface rust which may occur. Improper maintenance, salt spray, chemicals, pesticides will affect the look and integrity of the components of this grill. RCS will not be responsible for any damage caused as a result of not following owner's manual instructions. This non-transferrable warranty is limited to the replacement of original (one-time) defective parts, does not include shipping and labor to remove or install replacement parts, if necessary. The owner must retain and submit their original receipt with any warranty claim to receive warranty parts. The warranty applies to the original owner only. Coverage is for residential use only, no commercial applications apply. No registration required.

For more information, questions or assistance please contact us at:
RCSGasGrills.com ~ CustomerService@RCSGasGrills.com



Undercounter Slim Glass Door REFR5

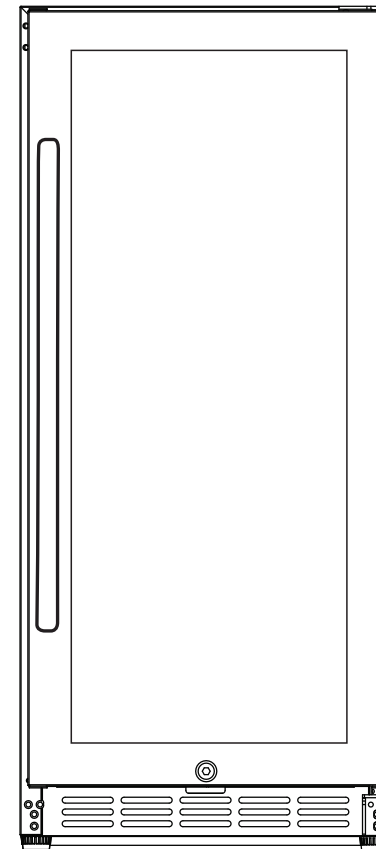

America's Best Value in Outdoor Kitchen Equipment

OWNER'S MANUAL

Read and save these instructions.



READ AND SAVE THESE INSTRUCTIONS.

TABLE OF CONTENTS

Safety Information & Warnings	3
Assembly & Installation	6
Operating Instructions	10
Cleaning & Maintenance.....	11
Troubleshooting.....	13

Problem	Possible Causes	Solution
The door will not close properly.	The fridge is not properly leveled.	Level the fridge with the adjustable feet or casters.
	The door was reversed and not properly installed.	Check the door hinge and reassemble correctly.
	The gasket is dirty.	Clean the door gasket.
	The shelves are out of position.	Check the shelves and refit correctly to make sure they don't interfere with the door.
The fridge is beeping consistently.	The door has been left open for more than 60 seconds.	Close the door and leave it closed for at least 15 minutes.
	The temperature has suddenly changed significantly from the set temperature.	Leave the door closed and wait for the unit to reach the set temperature.

Problem	Possible Causes	Solution
The fridge turns itself on and off frequently.	The room temperature is higher than normal.	Move the fridge to a cooler place.
	A large amount of food has been placed in the fridge.	Let the fridge run for a while to see if it reaches the set temperature.
	The door is being opened too often.	Do not open the door more often than necessary.
	The door was not closed completely.	Close door properly.
	The door is not hermetically sealed.	Check the door seal and clean or replace if it does not provide a proper seal.
The interior lighting doesn't work.	It isn't connected to a power supply.	Plug in the fridge.
	The lighting is turned off.	Turn on the lighting by pressing the lighting button on the control panel.
	The circuit breaker is tripped, or a fuse has been blown.	Turn the circuit breaker back on, or replace the fuse.
The fridge is vibrating or shaking a lot during operation.	The fridge is not properly leveled.	Level the fridge with the adjustable feet or casters.
The fridge is making too much noise.	As the refrigerant flows through the fridge, you may hear rattling or gurgling noises. Both are normal. When temperature fluctuation occurs, the expansion and contraction of the inner walls of the fridge may cause popping or crackling noises, which are also normal.	
	The fridge is not properly leveled.	Level the fridge with the adjustable feet or casters.

SAFETY INFORMATION & WARNINGS

Your safety and the safety of others is very important.



We have provided many important safety messages in this manual and on your appliance. Always read and obey all safety messages. This is the Safety Alert Symbol. The symbol alerts you to potential hazards that can kill or injure you and others. All safety messages will follow the Safety Alert Symbol and

either the word **DANGER** or **WARNING**.

DANGER means that failure to heed this safety statement may result in severe personal injury or death.

WARNING means that failure to heed this safety statement may result in extensive product damage, serious personal injury, or death.

All safety messages will alert you about the potential hazard, tell you how to reduce the chance of injury, and let you know what can happen if the instructions are not followed.

IMPORTANT SAFEGUARDS

Before the appliance is used, it must be properly positioned and installed as described in this manual, so please read the manual carefully. To reduce the risk of fire, electrical shock or injury when using the appliance, follow basic precautions, including the following:



DANGER

- Plug into a grounded 3 prong outlet, do not remove grounding prong, do not use an adapter, and do not use an extension cord.
- It is recommended that a separate circuit serving only your appliance be used. Do not use outlets that can be turned off by a switch or pull chain.
- Never clean appliance parts with flammable fluids. These fumes can create a fire hazard or explosion.
- Do not store or use gasoline or other flammable vapors and liquids in the vicinity of this or any other appliance. The fumes can create a fire hazard or explosion.
- Do not connect or disconnect the plug when your hands are wet.
- Unplug the appliance or disconnect power before cleaning or servicing. Failure to do so can result in electrical shock or death.

- Do not attempt to repair or replace any part of your appliance unless it is specifically recommended in this manual.



WARNING

FOLLOW WARNING CALLOUTS BELOW ONLY WHEN APPLICABLE TO YOUR MODEL

- Use two or more people to move and install the appliance. Failure to do so can result in injury.
- To ensure proper ventilation for your appliance, the front of the unit must be completely unobstructed.
- Choose a well-ventilated area with temperatures above 50°F (~10°C) and below 110°F (~43°C).
- The appliance should not be located next to ovens, grills or other sources of high heat.
- The appliance must be installed with all electrical, water, and drain connections (if applicable) in accordance with state and local codes. A standard electrical supply (110 V AC only, 60 Hz), properly grounded in accordance with the National Electrical Code and local codes and ordinances, is required.
- Do not kink or pinch the power cord of the appliance.
- It is important that the appliance be leveled in order to work properly. You may need to make several adjustments to the feet or wheels to level it.
- All installations must be in accordance with local plumbing code requirements (if applicable).
- Make certain that the pipes are not pinched, kinked or damaged during installation. (If applicable)
- Never allow children to operate, play with or crawl inside the appliance.
- Do not use solvent-based cleaning agents or abrasives on the interior. These cleaners may damage or discolor the interior.
- Use this appliance only for its intended purpose as described in this instruction manual.
- Keep fingers out of the "pinch point" areas. Clearances between the door and cabinet are necessarily small. Be careful closing the door when children are nearby.

TROUBLESHOOTING

You can solve many common problems easily, saving you the cost of time spent communicating with customer service. Try the suggestions below to see if the problem you're facing has a simple solution.

Problem	Possible Causes	Solution
The fridge isn't working.	It isn't connected to a power supply.	Plug in the fridge.
	The fridge isn't turned on.	Turn on the fridge.
	The circuit breaker is tripped, or a fuse has been blown.	Turn the circuit breaker back on, or replace the fuse.
The fridge isn't cold enough.	The temperature is not set correctly.	Check the set temperature.
	The ambient temperature could require a lower temperature setting.	Set to a lower temperature.
	The door is being opened too often.	Do not open the door more often than necessary.
	The door was not closed completely.	Close door properly.
	The door is not hermetically sealed.	Check the door seal and clean or replace if it does not provide a proper seal.
	The condenser is too dirty.	Clean the condenser when necessary.
	The ventilation opening is blocked or too dusty.	Clear any obstructions and clean the dust.

MOVING YOUR APPLIANCE

1. Remove all contents.
2. Securely tape down all loose items (shelves) inside your appliance.
3. Turn the adjustable legs up to the base to avoid damaging them.
4. Tape the door shut.
5. Be sure the fridge stays secure in an upright position during transportation. Also, protect the outside of the appliance with a blanket or similar item.

ENERGY SAVING TIPS

- The appliance should be placed in the coolest location possible, away from heat-producing appliances and out of direct sunlight.
- Ensure that the unit is adequately ventilated. Never cover air vents.
- Do not keep the door open any longer than necessary.
- Let hot foods cool to room temperature before storing them in the fridge.
- Do not overload the fridge, as it forces the compressor to run more frequently, increasing the power consumption.
- Be sure to wrap foods properly, and wipe containers dry before placing them in the fridge, in order to prevent frost buildup.
- Do not line shelves with aluminum foil, wax paper or paper towels, as they will prevent proper air circulation.

Attention: Child Entrapment Risk!

Child entrapment and suffocation are not problems of the past. Junked or abandoned appliances are still dangerous, even if they will "just sit for a few days."

Before discarding your old refrigerator, take off the doors, and leave the shelves in place so that children may not easily climb inside.

- SAVE THESE INSTRUCTIONS -

ASSEMBLY & INSTALLATION

BEFORE USING YOUR FRIDGE



Remove the exterior and interior packing.
Before plugging in the fridge, let it stand upright for approximately 24 hours.

Doing this will reduce the possibility of a malfunction in the cooling system from handling during transportation.

Clean the interior surface with lukewarm water using a soft cloth.

Install the handle on the door, if it is not already attached

INSTALLING THE FRIDGE

This fridge is designed to be either built-in or freestanding.

Note: This appliance may be used for the storage of medicine and other medical products.

Place your fridge on a floor that is strong enough to support it when it is fully loaded. To level the unit, adjust the front leveling legs, or the screws on the wheels.

Make sure that the air vent at the front of the appliance is never covered or blocked in any way.

Note: It is recommended that you do not install the appliance near an oven, radiator or other heating source. Any nearby heat sources may increase electrical consumption. Do not install in a location where the temperature will fall below 50°F (~10°C) or above 110°F (~43°C). For best performance, do not install the fridge behind a cabinet door or block the vent in the front.

Avoid installing the fridge anywhere with excessive moisture.

Plug the fridge into a properly grounded wall outlet. Do not plug the fridge into a power strip or extension cord.

CLEANING & MAINTENANCE

CLEANING YOUR FRIDGE

- Turn off the power, unplug the fridge, and remove all items, including shelves.
- Wash the inside surfaces with a solution of warm water and baking soda (about 2 tablespoons of baking soda per 4 cups of water).
- Wash the shelves with a mild detergent solution.
- Wring excess water out of the sponge or cloth before cleaning the area where the controls are located, or any place on or near electrical parts.
- Wash the outside of the fridge with warm water and a mild liquid detergent. Rinse well and wipe dry with a clean, soft cloth.
- Use an approved stainless steel cleaner to clean the door frame and handle. Do not use steel wool or a steel brush on the stainless steel.

CAUTION:

Failure to unplug the fridge during cleaning could result in electrical shock or other personal injury.

POWER FAILURE

Most power failures are corrected within a few hours and they should not affect the temperature of your fridge, as long as you avoid opening the door. If the power is going to be off for a longer period of time, it is recommended that you transfer all perishable/sensitive contents to a functional fridge or cooler. To prevent odor and mold growth, leave the door open slightly, blocking it open if necessary. Lay a towel down below the open front of the fridge in case any frost buildup melts and drains out.

VACATION TIME

Short vacations: Leave the fridge running during vacations that are shorter than three weeks.

Long vacations: If the fridge will not be used for a month or more, remove all items and turn it off. Clean and dry the interior thoroughly. To prevent odor and mold growth, leave the door open slightly, blocking it open if necessary. Lay a towel down below the open front of the fridge in case any frost buildup melts and drains out.

OPERATING INSTRUCTIONS

It is recommended that you install the appliance in a place where the ambient temperature is above 50°F (~10°C) and below 110°F (~43°C). If the ambient temperature is above or below the recommended range, the performance of the unit may be affected. For example, placing your unit in extremely cold or hot conditions may cause interior temperatures to fluctuate, preventing the fridge from reaching the target temperature.

CONTROL PANEL

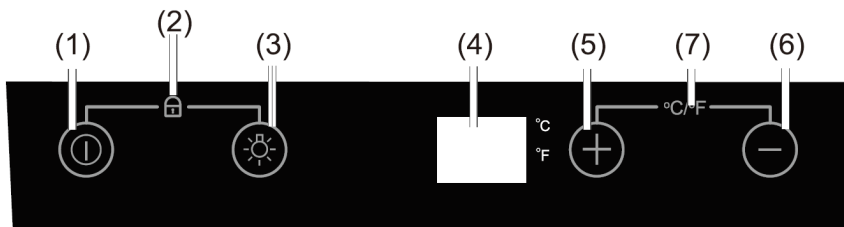

1. **Power:** Press and hold to enable or disable power to the unit, even while the unit is still plugged in.
2. **Control Lock:** Press and hold the power and light buttons simultaneously to lock or unlock the control panel. When the panel is locked, no buttons will work other than the unlock function.
3. **Lights:** Press to turn the interior light on or off.
4. **Display:** Shows the currently set target temperature.
5. **Temperature Increase:** Press once to increase temperature by 1°F.
6. **Temperature Decrease:** Press once to decrease temperature by 1°F.
7. **Celsius/Fahrenheit Switch:** Press and hold both temperature buttons to switch the display temperature between Celsius and Fahrenheit.

DOOR LOCK

Your unit comes with a lock and key. Insert the key into the lock and turn it counter-clockwise to unlock the door. To lock the door, turn the key clockwise, making sure the metal pin is engaged completely. Be sure to keep your keys in a safe place where they won't be easily lost.

“DOOR OPEN” ALARM

Your unit will start beeping if the door is left open for more than 60 seconds. Close the door to disable the alarm.

ELECTRICAL CONNECTION

WARNING

Improper use of the grounded plug can result in electrical shock.

This fridge should be properly grounded for your safety. The power cord of this fridge is equipped with a three-prong plug which fits with a standard three-prong wall outlet to minimize the possibility of electrical shock.

Do not under any circumstances cut or remove the third (ground) prong from the power cord supplied. For personal safety, this appliance must be properly grounded.

This appliance requires a standard 110 Volt AC 60Hz three-prong grounded electrical outlet. Ensure that the wall outlet and circuit been checked by a qualified electrician and confirmed to be properly grounded.

If only a 2-prong wall outlet is available, it is your responsibility and obligation to have it replaced with a properly grounded 3-prong wall outlet.

To prevent accidental injury, the cord should be secured behind the appliance and not left exposed or dangling.

This fridge should always be plugged into its own individual electrical outlet which has a voltage rating that matches the rating label on the appliance. This will allow the best performance and also prevent overloading house wiring circuits that could cause a fire hazard from overheating. Never unplug the fridge by pulling on the power cord. Always grip the plug head firmly and pull straight out from the receptacle. Immediately repair or replace all power cords that have become frayed or otherwise damaged. Do not use a cord that shows cracks or abrasion damage along its length or at either end.

When moving the appliance, be careful not to damage the power cord.

EXTENSION CORD

Because of potential safety hazards under certain conditions, it is strongly recommended that you do not use an extension cord with this appliance. However, if you must use an extension cord, it is absolutely necessary that it be a UL/CUL-Listed, 3-wire grounding type appliance extension cord having a grounding type plug and outlet and that the electrical rating of the cord be 110 volts.

INSTALLING THE STAINLESS STEEL HANDLE

To install the handle, follow the instructions below:

1. Remove the rubber gasket from the right side of the inside of the door (you don't need to remove the whole gasket, just the side that covers the openings for the screws).
2. Remove the screws from the included bag. Feed the screws through the holes from the inside until they poke through to the outside front of the door frame.
3. Align the handle with the two screws, then tighten the screws into the handle using a screwdriver until the handle is both flush and secured tightly against the door frame. **DO NOT** over-tighten the screws, as you may cause damage to the door frame.

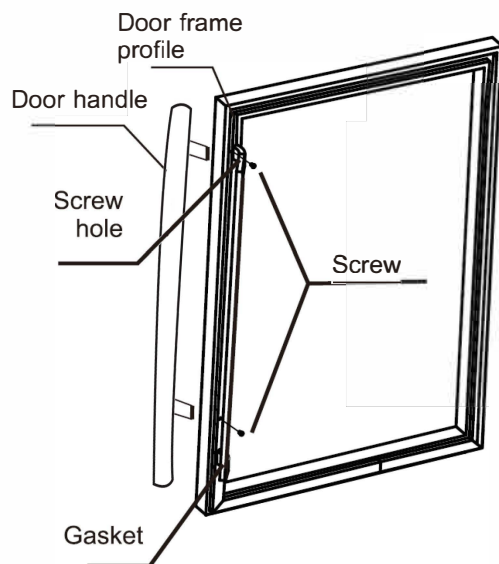

CASTER INSTALLATION (If Applicable)

1. Remove everything from the cabinet and lay the unit on its side on a clean, dry, and padded surface.
2. Install casters into the holes on the bottom of the unit (as shown in the picture below) and tighten screws with a screwdriver.
3. The two casters equipped with locks should be installed on the front of the unit.
4. Once all four casters are attached, stand the fridge upright on the wheels, making sure the fridge is still level.
5. Allow the unit to sit for 8-10 hours before plugging it in again. This allows the refrigerant to settle again, preventing potential malfunctions.

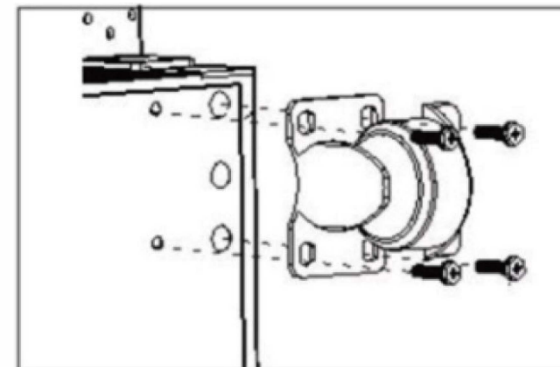



Renaissance Cooking Systems Product Warranty

RCS is proud to provide the industries most comprehensive warranty program.

All RCS **American Renaissance Grills, Cutlass Pro Series Grills and Cutlass Pro Series side burners, sinks, as well as ALL doors and drawers** are warranted to be free from manufacturer defects for the lifetime of the original owner.

All RCS **Premier Series Grills and Premier Series Side Burners** are warranted to be free from manufacturer defects for 15 years to the original owner.

All RCS **Refrigeration products** are warranted to be free from manufacturer defects for 5 years to the original owner.

All **other products** carry a one-year warranty to the original owner.

This RCS warranty is effective for product sales beginning January 1st, 2020.

For service assistance, please reach out to us at the website below.

This warranty excludes normal surface corrosion, discoloration, surface scratches and surface rust which may occur. Improper maintenance, salt spray, chemicals, pesticides will affect the look and integrity of the components of these products. RCS will not be responsible for any damage caused as a result of not following owner's manual instructions. This non-transferrable warranty is limited to the replacement of original (one-time) defective parts, does not include shipping and labor to remove or install replacement parts, if necessary. The owner must retain and submit their original receipt with any warranty claim to receive warranty parts. The warranty applies to the original owner only. Coverage is for residential use only, no commercial applications apply. No registration required.

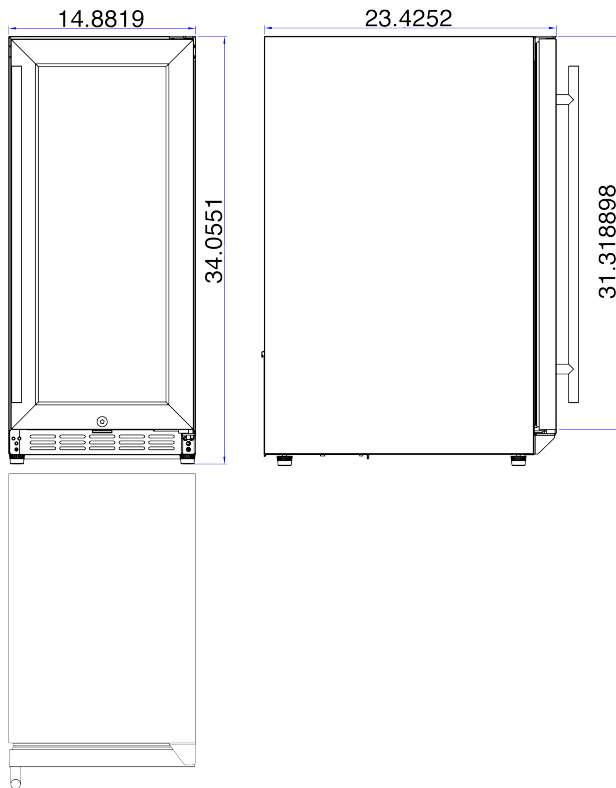

For more information, questions or assistance please visit us at RCSGasGrills.com and click the Customer Care Form.