

Double Magnetic Lock (600lb) With LED

Double magnetic lock (600lb) with red LED for wooden, glass, metal, and fireproof door

Features:

- Holding Force: 280kgx2 / 600Lbsx2
- Input Voltage: 12 or 24V DC
- Current Draw: 12V/500mA x2 / 24V/250mA x2
- Surface Temp: $\leq 20^{\circ}\text{C}$ / 68°F
- Operating Temp: -10 - 55°C (14 - 131°F)
- Humidity: 0~90% (non-condensing)
- Cover Finish: Anodized aluminum
- Lock Finish: Zinc
- Armature Plate Finish: Zinc
- Size: 500Lx48.5Wx25Hmm (19.69Lx1.91Wx0.98Hin)
- Armature Plate Dimension: 180Lx38Wx11Hmm (7.09Lx1.5Wx0.43Hin)
- Weight: 4.2kg (9.26lb)

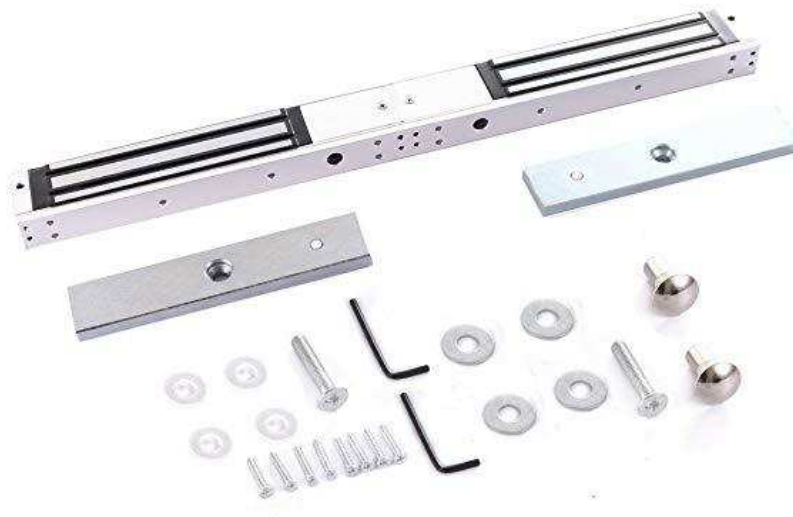

Wiring Diagram:

Access Control Keypad

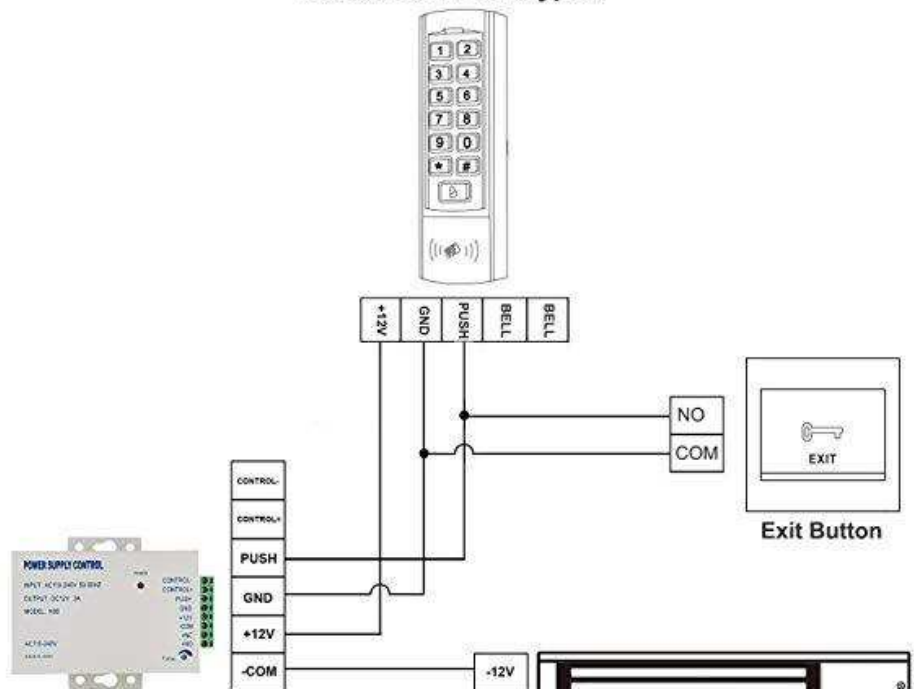

Diagram(unit:mm)

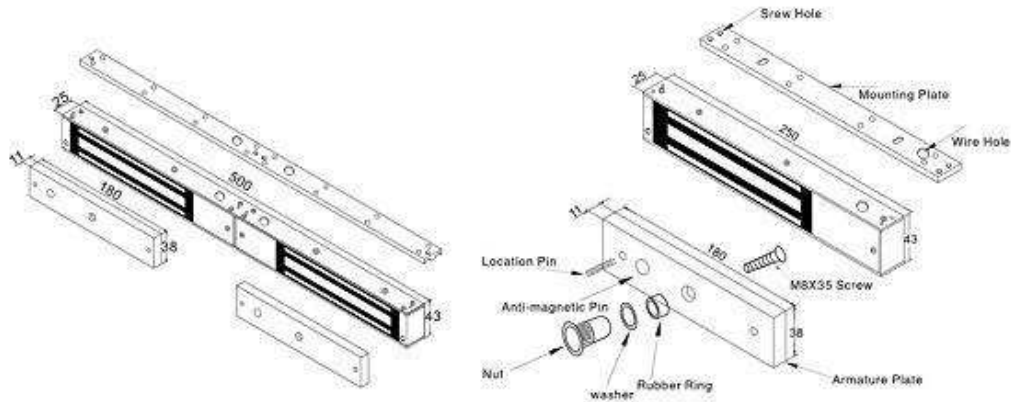

Installation Instruction

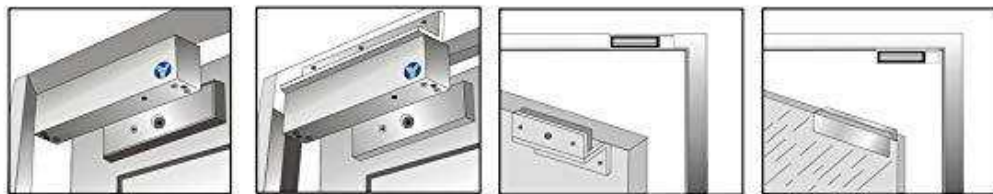

Demonstration of I Bracket Installation

Demonstration of L Bracket Installation

Demonstration of ZL Bracket Installation

Demonstration of UL Bracket Installation