



TransSteel 2200

EN-US

Operating Instructions

MIG/MAG Power source

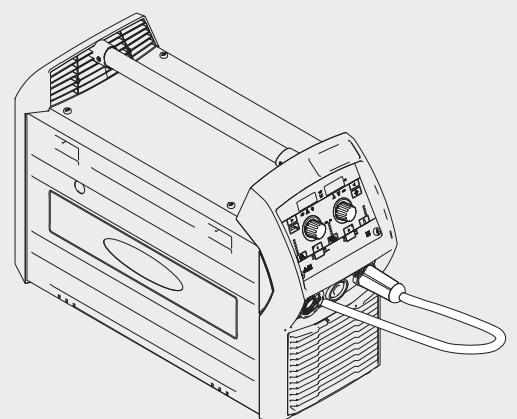

42,0426,0241,EA 005-06062019

Dear reader,

Introduction

Thank you for the trust you have placed in our company and congratulations on buying this high-quality Fronius product. These instructions will help you familiarize yourself with the product. Reading the instructions carefully will enable you to learn about the many different features your Fronius product has to offer. This will allow you to make full use of its advantages.

Please also note the safety rules to ensure greater safety when using the product. Careful handling of the product will repay you with years of safe and reliable operation. These are essential prerequisites for excellent results.

Explanation of Safety Instructions



DANGER!

Indicates an immediate danger.

- ▶ Death or serious injury may result if appropriate precautions are not taken.
-



WARNING!

Indicates a possibly dangerous situation.

- ▶ Death or serious injury may result if appropriate precautions are not taken.
-



CAUTION!

Indicates a situation where damage or injury could occur.

- ▶ Minor injury or damage to property may result if appropriate precautions are not taken.
-

NOTE!

Indicates the possibility of flawed results and damage to the equipment.

IMPORTANT!

Indicates tips for correct operation and other particularly useful information.

It does not indicate a potentially damaging or dangerous situation.

If you see any of the symbols depicted in the "Safety Rules," special care is required.

Contents

Safety	9
Safety Instructions	11
Explanation of Safety Instructions.....	11
General	11
Intended Use.....	12
Grid Connection	12
Environmental Conditions	12
Obligations of the Operating Company.....	13
Obligations of Personnel.....	13
Residual current circuit breaker	13
Personal Protection and Protection of Others.....	13
Data regarding Noise Emission Values	14
Danger from Toxic Gases and Vapors.....	14
Danger from Flying Sparks	14
Risks from Grid Current and Welding Current	15
Stray Welding Currents	16
EMC Device Classifications	16
EMC Measures	16
EMF measures.....	17
Particular Hazard Areas	17
Undesired Welding Results.....	18
Danger from Shielding Gas Cylinders.....	18
Danger Posed by Shielding Gas Leak	19
Safety Measures at the Setup Location and During Transport	19
Safety Measures in Normal Operation.....	20
Maintenance and repair	20
Safety Inspection	20
Disposal	21
Safety Symbols	21
Backup.....	21
Copyright.....	21
 General Information	 23
General	25
Device concept	25
"Power limitation" function	25
Application areas	26
Warning notices on the device.....	27
Description of Warning Notices on the Device.....	29
 Operating controls and connections	 31
Control Panel	33
General	33
Safety.....	33
Control panel.....	33
Keylock	38
Connections, Switches, and Mechanical Components	40
Safety.....	40
Front and rear of the power source.....	40
Side view.....	41
 Before installation and initial operation	 43
General	45
Safety.....	45
Intended use	45

Setup regulations	45
Grid Connection	46
Generator-Powered Operation.....	47
Generator-powered operation.....	47
Mains Fuse Protection	48
Adjustable mains fuse protection.....	48
Carrying Strap Option	51
Fitting the Carrying Strap	53
Fitting the carrying strap to the power source.....	53
MIG/MAG	55
Commissioning	57
Connecting a MIG/MAG welding torch.....	57
Inserting the feed rollers	58
Inserting the D100 wirespool	59
Inserting the D200 wirespool	59
Feeding in the wire electrode.....	60
Setting the contact pressure	61
Connecting the gas cylinder.....	62
Connecting the polarity reverser and establishing a grounding (earthing) connection	63
Adjusting the Brake of the Wirespool Holders	64
General	64
Adjusting the brake of the D200 wirespool holder	65
Adjusting the brake of the D100 wirespool holder	65
Description of MIG/MAG Operating Modes	66
2-step mode	66
4-step mode	66
Special 4-step mode	67
Spot welding	68
2-step stitch welding	69
4-step stitch welding	69
MIG/MAG Standard Manual Welding.....	71
General	71
Available parameters	71
MIG/MAG standard manual welding	71
Corrections during welding	71
MIG/MAG Standard Synergic Welding	72
MIG/MAG standard synergic welding	72
Corrections during welding	72
Spot and Stitch Welding.....	73
General	73
Spot welding	73
Stitch welding.....	73
TIG	75
Commissioning	77
Start-Up.....	77
TIG welding.....	78
Description of TIG Operating Modes	80
2-step mode	80
4-Step Mode	81
Pulse Welding	83
Applications.....	83
Operating Principle	83
Activating Pulse Welding	84
Rod Electrode	85
Commissioning	87
Preparation	87

Manual metal arc welding	88
Functions for Optimizing the Welding Process	89
Arc-Force Dynamic	89
HotStart (Hti) Function	89
Anti-stick (Ast) Function	89
EasyJobs	91
Saving and Retrieving EasyJobs	93
General	93
Saving an EasyJob	93
Retrieving an EasyJob	93
Deleting an EasyJob	93
Setup Menu	95
Setup Menu Level 1	97
Operation	97
Parameters for MIG/MAG Standard Manual Welding	98
Parameters for MIG/MAG Standard Synergic Welding	99
Parameters for TIG Welding	101
Parameters for MMA Welding	102
Setup Menu 2nd Level	103
Operation	103
Parameters for MIG/MAG welding	104
Parameters for MIG/MAG welding	105
Parameters for TIG Welding (Setup Menu 2nd Level)	107
Parameters for Manual Metal Arc Welding (Setup Menu 2nd Level)	108
Optimizing Weld Quality	109
Measuring the Welding Circuit Resistance r	111
General	111
Measuring the Welding Circuit Resistance r	111
Displaying the Welding Circuit Inductivity L	112
General	112
Displaying the Welding Circuit Inductivity L	112
Laying the Hosepacks Correctly	112
Troubleshooting and Maintenance	113
Displaying Service Parameters	115
Service parameters	115
Troubleshooting	116
Safety	116
Troubleshooting	116
Displayed Service Codes	119
Service, maintenance and disposal	123
General	123
Safety	123
At every start-up	123
As required, at least every two months	124
Every 6 Months	124
Disposal	124
Removing Stiff Drive Rollers	125
Removing a stiff drive roller	125
Technical Data	127
General	129

Special voltage.....	129
Explanation of the Term Duty Cycle	129
Technical Data	130
TSt 2200	130
TSt 2200 MV	131

Safety

Safety Instructions

Explanation of Safety Instructions



DANGER!

Indicates an immediate danger.

- ▶ Death or serious injury may result if appropriate precautions are not taken.



WARNING!

Indicates a possibly dangerous situation.

- ▶ Death or serious injury may result if appropriate precautions are not taken.



CAUTION!

Indicates a situation where damage or injury could occur.

- ▶ Minor injury or damage to property may result if appropriate precautions are not taken.

NOTE!

Indicates the possibility of flawed results and damage to the equipment.

IMPORTANT!

Indicates tips for correct operation and other particularly useful information.

It does not indicate a potentially damaging or dangerous situation.

If you see any of the symbols depicted in the "Safety Rules," special care is required.

General

The device has been manufactured using state-of-the-art technology and according to recognized safety standards. If used incorrectly or misused, however, it can cause

- Injury or death to the operator or a third party
- Damage to the device and other material assets belonging to the operating company
- Inefficient operation of the equipment

All persons involved in the commissioning, operation, maintenance, and servicing of the device must

- Be suitably qualified
- Have knowledge of welding
- Have completely read and followed these Operating Instructions

The Operating Instructions must always be at hand wherever the device is being used. In addition to the Operating Instructions, all applicable local rules and regulations regarding accident prevention and environmental protection must also be followed.

All safety and danger notices on the device must

- Be kept in a legible state
- Not be damaged/marked
- Not be removed
- Not be covered, pasted, or painted over

For the location of the safety and danger notices on the device, refer to the section headed "General" in the Operating Instructions for the device.

Before switching on the device, remove any faults that could compromise safety.

Your personal safety is at stake!

Intended Use

The device is to be used exclusively for its intended purpose.

The device is intended exclusively for the welding process specified on the rating plate. Utilization for any other purpose, or in any other manner, shall be deemed to be "not in accordance with the intended purpose." The manufacturer is not responsible for any damage resulting from improper use.

Proper use also means

- Completely reading and obeying all instructions in the Operating Instructions
- Completely reading and obeying all safety instructions and danger notices
- Carrying out all the specified inspection and servicing work

Never use the device for the following applications:

- Thawing pipes
- Charging batteries
- Starting motors

The device is designed for operation in industry and business. The manufacturer shall not be liable for any damage resulting from use in a living area.

The manufacturer shall also not be liable for faulty or incorrect work results.

Grid Connection

Devices with a high output can influence the energy quality of the grid due to their current consumption.

This may affect a number of device types in terms of:

- connection restrictions
- criteria regarding maximum permissible grid impedance *)
- criteria regarding the minimum required short-circuit power *)

*) both at the interface with the public grid

See technical data

In this case, the operator or the person using the device should check whether or not the device is allowed to be connected, where appropriate through discussion with the power supply company.

IMPORTANT! Ensure secure grounding of the grid connection!

Environmental Conditions

Operation or storage of the device outside the stipulated area will be deemed as not in accordance with the intended purpose. The manufacturer accepts no liability for any damage resulting from improper use.

Temperature range of the ambient air:

- During operation: -10°C to +40°C (14°F to 104°F)
- During transport and storage: -20°C to +55°C (-4°F to 131°F)

Relative humidity:

- Up to 50% at 40°C (104°F)
- Up to 90% at 20°C (68°F)

Ambient air: free of dust, acids, corrosive gases or substances, etc.

Altitude above sea level: up to 2000 m (6561 ft. 8.16 in.)

Obligations of the Operating Company	<p>The operating company must only allow persons to work with the device if they</p> <ul style="list-style-type: none"> - Are familiar with the basic occupational safety and accident prevention regulations and are trained in handling the device - Have read and understood these Operating Instructions, especially the section "Safety Rules," and have confirmed this with their signature - Are trained according to the requirements for the work results
---	---

The safety-conscious work of the personnel must be checked regularly.

Obligations of Personnel	<p>All persons who are assigned to work with the device must do the following before beginning the work:</p> <ul style="list-style-type: none"> - Follow the basic regulations for occupational safety and accident prevention - Read these Operating Instructions, especially the section "Safety Rules," and confirm that they have understood and will follow them by signing
---------------------------------	--

Before leaving the workplace, ensure that no personal injury or property damage can occur in one's absence.

Residual current circuit breaker	<p>Local regulations and national guidelines may mean that a residual current circuit breaker is required when connecting a device to the public grid.</p> <p>The residual current circuit breaker recommended for the device by the manufacturer can be found in the technical data.</p>
---	---

Personal Protection and Protection of Others	<p>You are exposed to numerous hazards while handling the device, for example:</p> <ul style="list-style-type: none"> - Flying sparks and pieces of hot metal - Arc radiation that poses a risk of injury to the eyes and skin - Hazardous electromagnetic fields that pose a risk of death for individuals with pacemakers - Electrical risks from grid current and welding current - Increased noise exposure - Harmful welding fumes and gases
---	---

Wear suitable protective clothing when dealing with the device. The protective clothing must have the following properties:

- Flame resistant
 - Insulating and dry
 - Covering the entire body and in good condition with no damage
 - Safety helmet
 - Cuffless pants
-

Protective clothing involves the following:

- Protecting the face and eyes from UV radiation, heat and flying sparks with a face guard featuring a regulation-compliant filter
 - Wearing regulation-compliant protective goggles with side protection behind the face guard
 - Wearing rigid, wet-insulating footwear
 - Protecting hands with appropriate gloves (featuring electrical insulation and thermal protection)
 - Wearing ear protection to reduce noise exposure and protect against injury
-

Keep persons, especially children, away during the operation of the devices and during the welding process. If persons are in the vicinity, however:

- Instruct them about all hazards (blinding hazard due to arcs, risk of injury from flying sparks, welding fumes hazardous to health, noise exposure, possible hazard due to grid current or welding current, etc.)
- Provide suitable protective equipment or
- Construct suitable protective walls and curtains.

**Data regarding
Noise Emission
Values**

The device produces a maximum noise level of <80 dB(A) (ref. 1pW) when idling and in the cooling phase following operation in relation to the maximum permitted operating point at standard loading in accordance with EN 60974-1.

A workplace-specific emission value for welding (and cutting) cannot be specified because this value depends on the welding process and the environmental conditions. It is influenced by a wide range of parameters, such as the welding process itself (MIG/MAG, TIG welding), the selected current type (direct current, alternating current), the power range, the type of weld metal, the resonance properties of the workpiece, the workplace environment, and many other factors.

**Danger from Toxic
Gases and Va-
pors**

The fumes produced during welding contain toxic gases and vapors.

Welding fumes contain substances that can cause cancer, as stated in monograph 118 from the International Agency for Research on Cancer.

Use at-source extraction source and a room extraction system.
If possible, use a welding torch with an integrated extraction device.

Keep your head out of the welding fumes and gases.

Take the following precautionary measures for fumes and harmful gases:

- Do not breathe them in
- Extract them from the work area using appropriate equipment

Ensure there is a sufficient supply of fresh air with a ventilation flow rate of at least 20 m³ per hour.

Use breathing apparatus with air supply if there is insufficient ventilation.

When no welding is taking place, close the valve of the shielding gas cylinder or the main gas supply.

If there is uncertainty as to whether the extraction capacity is sufficient, compare the measured toxic emission values against the permissible limit values.

The following components are factors that determine how toxic the welding fumes are:

- The metals used for the workpiece
- Electrodes
- Coatings
- Cleaning agents, degreasers, and the like

Consult the corresponding material safety data sheets and manufacturer's instructions for the components listed above.

Keep flammable vapors (such as solvent vapors) out of the arc radiation range.

**Danger from Fly-
ing Sparks**

Flying sparks can cause fires and explosions.

Never undertake welding near flammable materials.

Flammable materials must be kept at least 11 meters (36 ft. 1.07 in.) from the arc or protected with a certified cover.

Keep suitable, tested fire extinguishers on hand.

Sparks and pieces of hot metal may also get into surrounding areas through small cracks and openings. Take appropriate measures to ensure that there is no risk of injury or fire.

Do not undertake welding in areas at risk of fire and explosion, or on sealed tanks, drums, or pipes if these have not been prepared in accordance with corresponding national and international standards.

Do not undertake welding on containers in which gases, fuels, mineral oils, and the like are/were stored. Residues pose a risk of explosion.

Risks from Grid Current and Welding Current

An electric shock is life-threatening and may be deadly.

Do not touch voltage-carrying parts inside or outside of the device.

During MIG/MAG welding and TIG welding, the welding wire, the wirespool, the feed rollers, as well as all pieces of metal that are in contact with the welding wire, are live.

Always place the wirefeeder on a sufficiently insulated base or use a suitable insulating wirefeeder holder.

Ensure suitable personal protection with dry temporary backing or cover with sufficient insulation against the ground potential. The temporary backing or cover must completely cover the entire area between the body and the ground potential.

All cables and leads must be secured, undamaged, insulated, and adequately dimensioned. Replace loose connections and scorched, damaged, or inadequately dimensioned cables and leads immediately.

Before every use, check power connections for secure fit by hand.

In the case of power cables with bayonet connectors, turn the power cable by at least 180° around the longitudinal axis and pretension.

Do not wrap cables or leads around your body or parts of the body.

Concerning the electrode (rod electrode, tungsten electrode, welding wire, etc.)

- never immerse it in liquids to cool it
- never touch it when the power source is switched on.

The open circuit voltage of a welding system may double, for example, between the electrodes of two welding systems. Touching the potentials of both electrodes at the same time may be life-threatening in some cases.

Have the grid and device supply lead regularly inspected by an electrician to ensure that the ground conductor is functioning properly.

Only operate the device on a grid with a ground conductor and a socket with a ground conductor contact.

Operating the device on a grid without a ground conductor and on a socket without a ground conductor contact is considered gross negligence. The manufacturer accepts no liability for any damage resulting from improper use.

Use suitable equipment to ensure that the workpiece is sufficiently grounded if necessary.

Switch off unused devices.

When working at elevated heights, wear a safety harness to prevent falls.

Before working on the device, switch off the device and remove the grid plug.

Secure the device to prevent the grid plug from being connected and switched on again by applying a clearly legible and understandable warning sign.

After opening the device:

- Discharge all electrically charged components
 - Ensure that all components are disconnected from the power supply
-

If work is needed on voltage-carrying parts, bring in a second person who will switch off the main switch at the correct time.

Stray Welding Currents

If the following instructions are not observed, stray welding currents may occur, which pose a risk of the following:

- Fire
 - Overheating of components connected to the workpiece
 - Destruction of ground conductors
 - Damage to the device and other electrical equipment
-

Ensure that the workpiece terminal is securely connected to the workpiece.

Secure the workpiece terminal as close to the spot to be welded as possible.

If the floor is electrically conductive, ensure that there is sufficient insulation between the device and the floor.

Observe the following when using electrical distributors, double-headed retainers, etc.: Even the electrode of the welding torch/electrode holder not in use carries electric potential. Ensure that there is sufficient insulation when the unused welding torch/electrode holder is stored.

In automated MIG/MAG applications, only guide the wire electrode from the welding wire drum, large spool or wirepool to the wirefeeder with insulation.

EMC Device Classifications

Devices in emission class A:

- Are only designed for use in industrial settings
 - Can cause line-bound and radiated interference in other areas
-

Devices in emission class B:

- Satisfy the emissions criteria for residential and industrial areas. This is also true for residential areas in which the energy is supplied from the public low-voltage grid.
-

EMC device classification as per the rating plate or technical data.

EMC Measures

In certain cases, even though a device complies with the standard limit values for emissions, it may affect the application area for which it was designed (e.g., when there is sensitive equipment at the same location, or if the site where the device is installed is close to either radio or television receivers).

If this is the case, then the operating company is obliged to take appropriate action to rectify the situation.

Test and assess the immunity of equipment in the vicinity of the device in accordance with national and international provisions. Examples of interference-prone equipment that could be affected by the device:

- Safety devices
 - Grid power lines, signal lines and data transfer lines
 - EMC and telecommunications equipment
 - Devices for measuring and calibrating
-

Supporting measures to avoid EMC problems:

1. Grid power supply
 - If electromagnetic interference occurs despite a grid connection that complies with regulations, take additional measures (e.g., use a suitable grid filter).
2. Welding power-leads
 - Keep them as short as possible
 - Route them close together (also to avoid EMF problems)
 - Route them far from other lines
3. Equipotential bonding
4. Workpiece grounding
 - If necessary, establish grounding using suitable capacitors
5. Shield, if necessary
 - Shield other devices in the vicinity
 - Shield the entire welding installation

EMF measures

Electromagnetic fields may cause health problems that are not yet known:

- Effects on the health of persons close by, e.g., those with pacemakers and hearing aids
- Persons with pacemakers must seek advice from their doctor before staying in the immediate vicinity of the device and the welding process
- Keep distances between welding cables and the head/torso of the welder as large as possible for safety reasons
- Do not carry welding cables and hosepacks over one's shoulder or wrap them around one's body or body parts

Particular Hazard Areas

Keep hands, hair, loose clothing, and tools away from moving parts, such as:

- fans
- gears
- rollers
- shafts
- wirepools and welding wires.

Do not reach into rotating gears of the wire drive or into rotating drive parts.

Covers and side parts must only be opened/removed during maintenance and repair work.

During operation:

- Ensure that all covers are closed, and all side parts have been mounted properly.
- Keep all covers and side parts closed.

The protrusion of welding wire from the welding torch represents a high risk of injury (cuts to the hand, facial and eye injuries, etc.)

Therefore always hold the welding torch away from the body (devices with wirefeeder) and use suitable protective goggles.

Do not touch the workpiece during or after welding—burning hazard.

Slag may fly off cooling workpieces. Therefore, also wear regulation-compliant protective equipment when reworking workpieces and ensure that other persons are sufficiently protected.

Leave the welding torch and other parts with a high operating temperature to cool before working on them.

Special regulations apply in areas at risk of fire or explosion
– follow the appropriate national and international regulations.

Power sources for work in areas with increased electrical hazard (e.g. boilers) must be labeled with the symbol (Safety). However, the power source may not be located in such areas.

Risk of scalding due to leaking coolant. Switch off the cooling unit before disconnecting connections for the coolant supply or return.

When handling coolant, observe the information on the coolant safety data sheet. The coolant safety data sheet can be obtained from your service center or via the manufacturer's website.

Only use suitable load-carrying equipment from the manufacturer when transporting devices by crane.

- Attach chains or ropes to all designated attachments of the suitable load-carrying equipment.
 - Chains or ropes must be the smallest angle possible from vertical.
 - Remove gas cylinder and wirefeeder (MIG/MAG and TIG devices).
-

In the event of crane attachment of the wirefeeder during welding, always use a suitable, insulating wirefeeder hoisting attachment (MIG/MAG and TIG devices).

If the device is equipped with a carrier belt or handle, then this is used exclusively for transport by hand. The carrier belt is not suitable for transport by crane, counterbalanced lift truck or other mechanical lifting tools.

All lifting equipment (belts, buckles, chains, etc.), which is used in association with the device or its components, must be checked regularly (e.g. for mechanical damage, corrosion, or changes due to other environmental influences).

The test interval and scope must at least comply with the respective valid national standards and guidelines.

There is a risk of colorless, odorless shielding gas escaping without notice if an adapter is used for the shielding gas connection. Use suitable Teflon tape to seal the thread of the shielding gas connection adapter on the device side before installation.

Undesired Welding Results

The following specifications concerning shielding gas quality must be met in order to ensure the safe and proper function of the welding system:

- Solid particle size < 40 µm
 - Pressure condensation point < -20 °C
 - Max. oil content < 25 mg/m³
-

Use filters if necessary.

IMPORTANT! Ring lines in particular pose a risk of contamination.

Danger from Shielding Gas Cylinders

Shielding gas cylinders contain compressed gas and may explode if damaged. Shielding gas cylinders are an integral part of the welding equipment, so they must be handled very carefully.

Protect shielding gas cylinders with compressed gas from excessive heat, mechanical impact, slag, open flames, sparks, and arcs.

Mount the shielding gas cylinders vertically and secure them in accordance with instructions so they cannot fall over.

Keep shielding gas cylinders away from welding or other electrical circuits.

Never hang a welding torch on a shielding gas cylinder.

Never touch a shielding gas cylinder with an electrode.

Risk of explosion: Never weld on a compressed shielding gas cylinder.

Always use suitable shielding gas cylinders for the application in question and the correct matching accessories (controller, hoses, and fittings, etc.) Only use shielding gas cylinders and accessories that are in good condition.

If a valve on a shielding gas cylinder is open, turn your face away from the outlet.

When no welding is taking place, close the valve of the shielding gas cylinder.

Leave the cap on the valve of the shielding gas cylinder when the cylinder is not connected.

Follow the manufacturer's instructions and applicable national and international provisions for shielding gas cylinders and accessories.

Danger Posed by Shielding Gas Leak

Risk of asphyxiation due to uncontrolled shielding gas leak

Shielding gas is colorless and odorless and may suppress the oxygen in the ambient air in the event of leakage.

- Ensure there is a sufficient supply of fresh air with a ventilation flow rate of at least 20 m³ per hour.
- Please observe the safety and maintenance information for the shielding gas cylinder or the main gas supply.
- When no welding is taking place, close the valve of the shielding gas cylinder or the main gas supply.
- Always check the shielding gas cylinder or main gas supply for uncontrolled gas leakage before each start-up.

Safety Measures at the Setup Location and During Transport

A toppling device can be deadly! Set up the device securely on an even, solid surface

- The maximum permitted tilt angle is 10°.

Special regulations apply in areas at risk of fire or explosion

- Follow the appropriate national and international regulations.

Use instructions and checks within the company to ensure that the vicinity of the workplace is always clean and organized.

Only set up and operate the device in accordance with the protection class shown on the rating plate.

When setting up the device, ensure that there is an all-round clearance of 0.5 m (1 ft. 7.69 in.) to allow cooling air to circulate unhindered.

Take care to ensure that the applicable national and regional guidelines and accident prevention regulations are observed when transporting the device, especially guidelines concerning hazards during transport and shipment.

Do not lift or transport any active devices. Switch off devices before transport or lifting.

Before transporting the device, completely drain the coolant and dismantle the following components:

- wirefeeder
- wirespool
- shielding gas cylinder

It is essential to conduct a visual inspection of the device to check for damage after it has been transported but before commissioning. Have any damage repaired by trained service technicians before commissioning the device.

**Safety Measures
in Normal Opera-
tion**

Only operate the device when all safety devices are fully functional. If the safety devices are not fully functional, there is a danger of:

- Injury or death to the operator or a third party
- Damage to the device and other material assets belonging to the operating company
- Inefficient operation of the device

Safety devices that are not fully functional must be repaired before the device is switched on.

Never bypass or disable safety devices.

Before switching on the device, ensure that no one can be put in danger.

The device must be examined at least once a week for externally detectable damage and functionality of the safety devices.

Always secure the shielding gas cylinder well and remove before transporting by crane.

Only the original coolant from the manufacturer is suitable for use in our devices due to its properties (electrical conductivity, anti-freeze, material compatibility, flammability, etc.)

Only use appropriate original coolant from the manufacturer.

Do not mix original coolant from the manufacturer with other coolants.

Only connect system components from the manufacturer to the cooling unit circuit.

If there is damage due to use of other system components or other coolants, the manufacturer accepts no liability for this and all warranty claims are forfeited.

Cooling Liquid FCL 10/20 is not flammable. The ethanol-based coolant is flammable in certain conditions. Only transport the coolant in closed original containers and keep away from sources of ignition.

Properly dispose of used coolant according to national and international regulations. The coolant safety data sheet can be obtained from your service center or via the manufacturer's website.

When the system is cool, always check the coolant level before starting welding.

**Maintenance and
repair**

It is impossible to guarantee that bought-in parts are designed and manufactured to meet the demands made of them, or that they satisfy safety requirements.

- Use only original spare and wearing parts (also applies to standard parts).
- Do not carry out any modifications, alterations, etc. to the device without the manufacturer's consent.
- Components that are not in perfect condition must be replaced immediately.
- When ordering, please give the exact designation and part number as shown in the spare parts list, as well as the serial number of your device.

The housing screws provide the ground conductor connection for earthing the housing parts.

Only use original housing screws in the correct number and tightened to the specified torque.

Safety Inspection

The manufacturer recommends that a safety inspection of the device be performed at least every 12 months.

The manufacturer recommends calibrating power sources within the same 12-month interval.

A safety inspection by a certified electrician is recommended:

- After changes
- After alterations
- After repair, care, and maintenance
- At least every 12 months

For the safety inspection, follow the appropriate national and international standards and guidelines.

You can obtain more information about the safety inspection and calibration from your service center. The service center will provide the necessary documents upon request.

Disposal

Do not dispose of this device with normal domestic waste! To comply with the European Directive on Waste Electrical and Electronic Equipment and its implementation as national law, electrical equipment that has reached the end of its life must be collected separately and returned to an approved recycling facility. Any device that you no longer require must be returned to your dealer, or you must locate the approved collection and recycling facilities in your area. Ignoring this European Directive may have potentially adverse affects on the environment and your health!

Safety Symbols

Devices with the CE label satisfy the essential requirements of the low-voltage and electromagnetic compatibility directive (e.g. relevant product standards of the EN 60974 series).

Fronius International GmbH declares that the device complies with Directive 2014/53/EU. The full text of the EU Declaration of Conformity is available on the following website: <http://www.fronius.com>

Devices marked with the CSA test mark satisfy the requirements of the relevant standards for Canada and the USA.

Backup

The user is responsible for backing up any changes made to the factory settings. The manufacturer accepts no liability for any deleted personal settings.

Copyright

Copyright of these operating instructions remains with the manufacturer.

Text and illustrations are technically correct at the time of going to print. The right to make modifications is reserved. The contents of the operating instructions shall not provide the basis for any claims whatsoever on the part of the purchaser. If you have any suggestions for improvement, or can point out any mistakes that you have found in the operating instructions, we will be most grateful for your comments.

General Information

Device concept

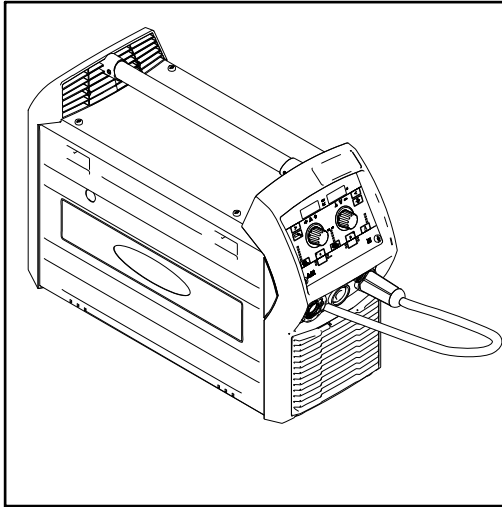

The TransSteel (TSt) 2200 power source is a completely digitized, microprocessor-controlled power source.

This power source is designed for the welding of steel and can be used for the following welding processes:

- MIG/MAG welding
- Manual metal arc welding
- TIG welding with touch-down ignition

The central control and regulation unit of the power source is coupled with a digital signal processor. The central control and regulation unit and signal processor control the entire welding process.

During the welding process, the actual data is measured continuously and the device responds immediately to any changes. Control algorithms ensure that the desired target state is maintained.

"Power limitation" function

The power source has a "Power limitation" safety feature.

This function is only available for the MIG/MAG standard synergic welding process.

Mode of operation:

If necessary, the power source reduces the welding power to prevent the arc from being extinguished during welding at the power limit of the power source. The reduced parameters are displayed on the control panel until welding starts again or until the next parameter change.

This results in:

- A more precise welding process
- A high degree of reproducibility of all results
- Exceptional weld properties

As soon as the function is active, the indicator for the wire speed parameter on the control panel flashes.  The flashing continues until welding starts again or until the next parameter change.

Application areas

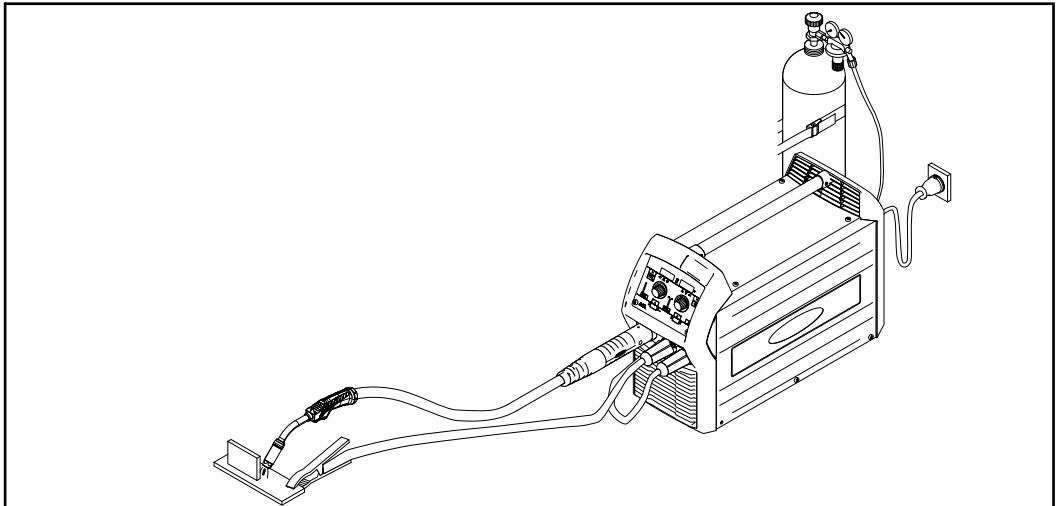

MIG/MAG welding

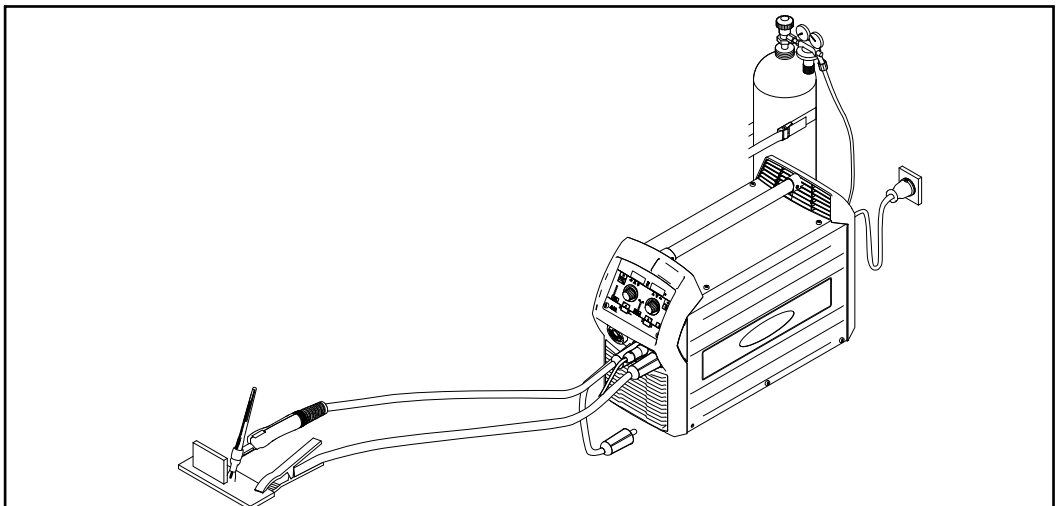

TIG welding

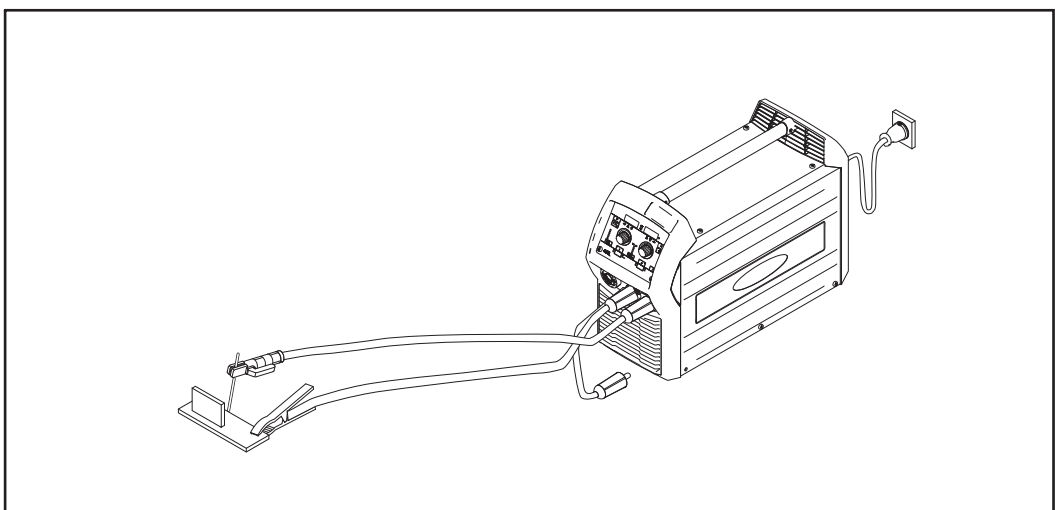

Manual metal arc welding



Dispose of old devices in accordance with safety rules and not in normal domestic waste.



Keep hands, hair, loose clothing, and tools away from moving parts, such as:

- gears
- feed rollers
- wire spools and welding wires.

Do not reach into rotating gears of the wire drive or into rotating drive parts.

Covers and side parts must only be opened/removed during maintenance and repair work.

Description of Warning Notices on the Device

On certain device versions, warning notices are attached to the device.

The arrangement of the symbols may vary.

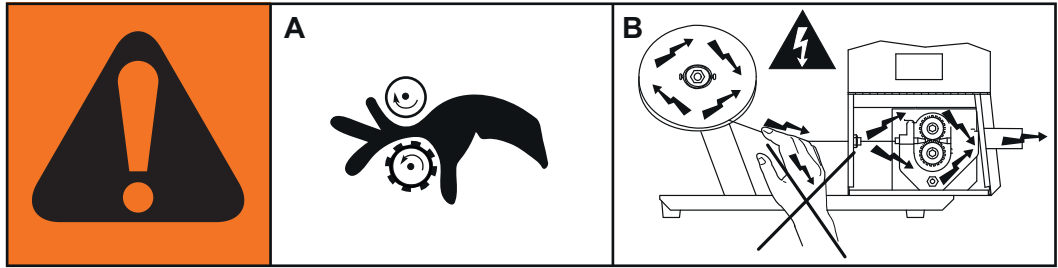

Warning! Watch Out!

There are possible hazards as shown by the symbols.

A Drive rolls can injure fingers.

B Welding wire and drive parts are at welding voltage during operation. Keep hands and metal objects away.

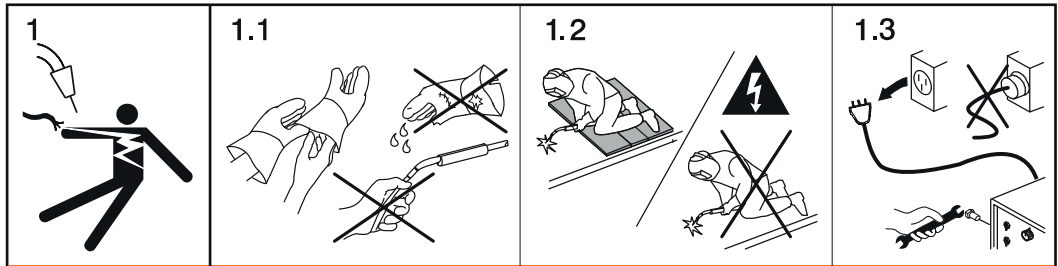

1. Electric shock can kill.

1.1 Wear dry insulating gloves. Do not touch electrode with bare hand. Do not wear wet or damaged gloves.

1.2 Protect yourself from electric shock by insulating yourself from work and ground.

1.3 Disconnect input plug or power before working on machine

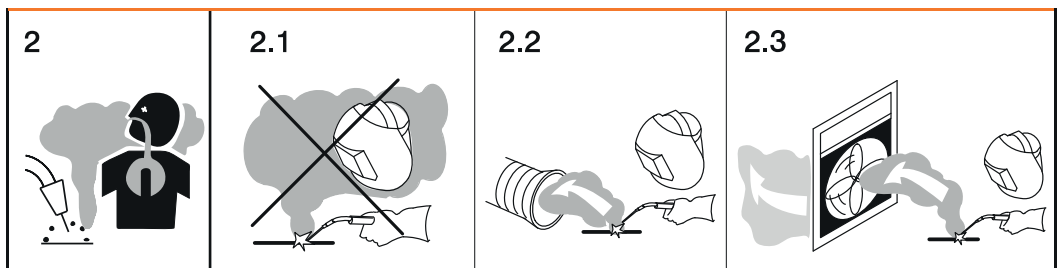

2. Breathing welding fumes can be hazardous to your health.

2.1 Keep your head out of the fumes.

2.2 Use forced ventilation or local exhaust to remove the fumes.

2.3 Use ventilating fan to remove fumes.

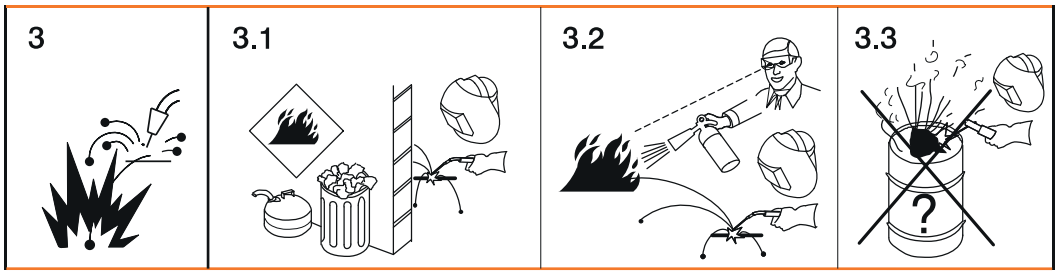

3 Welding sparks can cause explosion or fire.

3.1 Keep flammables away from welding. Don't weld near flammables.

3.2 Welding sparks can cause fires. Have a fire extinguisher nearby and have a watch-person ready to use it.

3.3 Do not weld on drums or any closed containers.

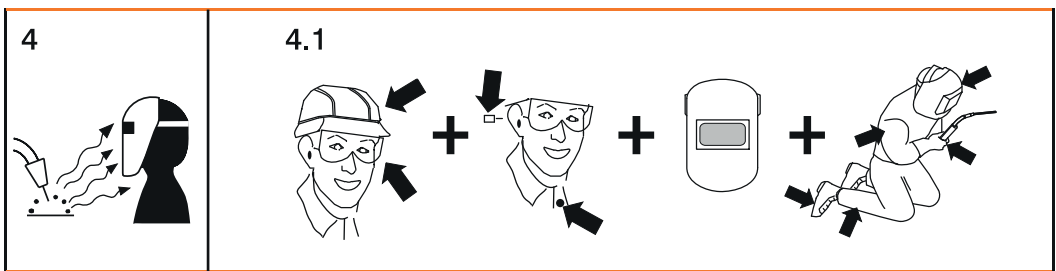

4. Arc rays can burn eyes and injure skin.

4.1 Wear hat and safety glasses. Use ear protection and button shirt collar. Use welding helmet with correct shade of filter. Wear complete body protection.

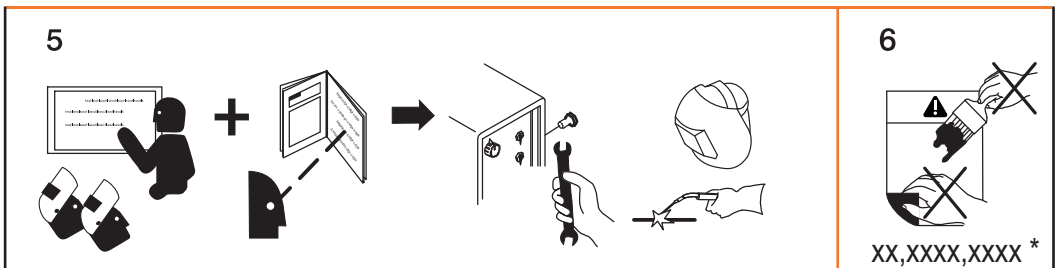

5. Become trained and read the instructions before working on the machine or welding.

6. Do not remove or paint over (cover) the label.

* identifying number to order label from manufacturer

Operating controls and connections

Control Panel

General

As a result of software updates, you may find that there are functions available on your device that are not described in these Operating Instructions, or vice versa. Certain illustrations may also differ slightly from the actual controls on your device, but these controls function in exactly the same way.

Safety



WARNING!

Danger from incorrect operation and work that is not carried out properly.

Serious personal injury and damage to property may result.

- ▶ Read and understand this document.
- ▶ Read and understand all the Operating Instructions for the system components, especially the safety rules.

Control panel

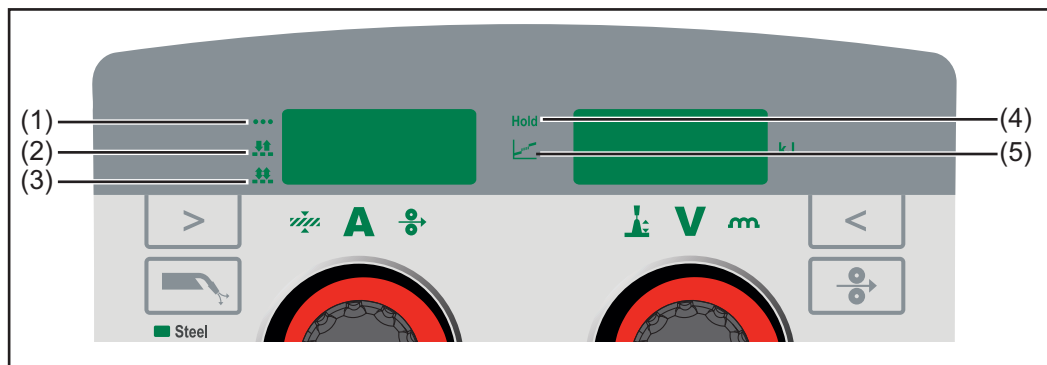

No.	Function
(1)	Spot welding indicator The spot welding indicator lights up if: <ul style="list-style-type: none"> - Spot welding/stitch welding mode is selected - The SPt parameter (spot welding time/stitch welding time) in the Setup menu is not set to OFF
(2)	2-step stitch welding indicator The 2-step stitch welding indicator lights up if: <ul style="list-style-type: none"> - Spot welding/stitch welding mode is selected and - The SPb parameter (spot welding/stitch welding pause time) is set to a value greater than 0 and - The Int (interval) parameter is set to 2T
(3)	4-step stitch welding indicator The 4-step stitch welding indicator lights up if: <ul style="list-style-type: none"> - Spot welding/stitch welding mode is selected and - The SPb parameter (spot welding/stitch welding pause time) is set to a value greater than 0 and - The Int (interval) parameter is set to 4T

(4) Hold indicator

At the end of each welding operation, the actual values for welding current and welding voltage are stored - the "HOLD" indicator lights up

(5) Intermediate arc indicator

A spatter-prone intermediate arc occurs between the dip transfer arc and the spray arc. The intermediate arc indicator lights up to alert you to this critical range

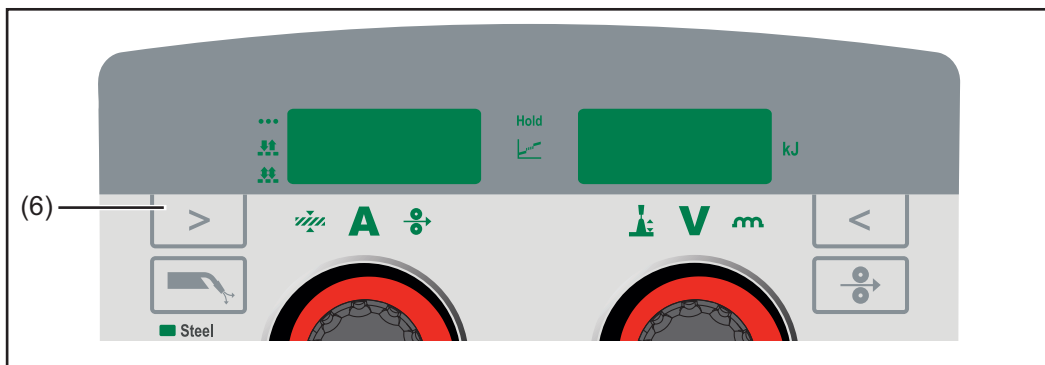

No. Function

- (6) **"Parameter selection" button (left)**
 For selecting the parameters listed below

The relevant symbol lights up when a welding parameter is selected.

// Sheet thickness in mm or inch *)

If the welding current to be selected is not known, it is sufficient to enter the sheet thickness. The required welding current and any other parameters marked with *) will then be adjusted automatically.

A Welding current in amperes *)

Before the start of welding, the device automatically displays a standard value based on the programmed parameters. The actual value is displayed during welding.

⊖ Wire speed in m/min or ipm *)

*) = Synergic parameter. If one of these parameters is selected in the MIG/MAG standard synergic welding process, then the synergic function ensures that all other synergic parameters are adjusted automatically.

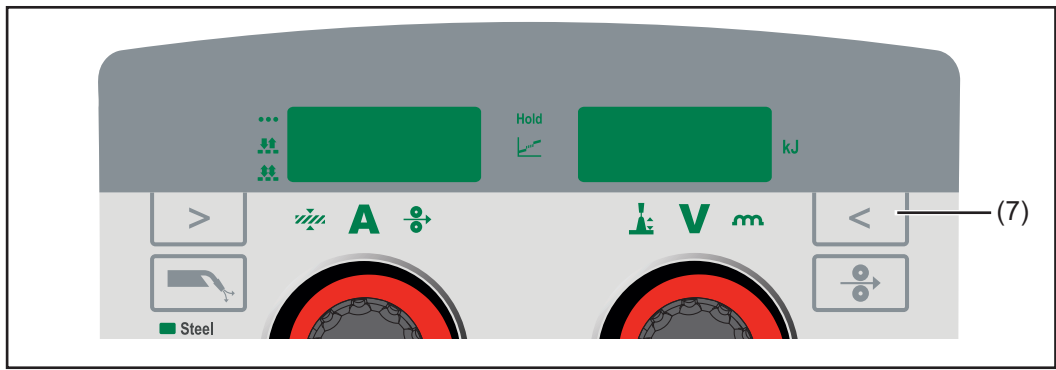

No. Function

- (7) **"Parameter selection" button (right)**
 For selecting the parameters listed below

The relevant symbol lights up when a welding parameter is selected.

 **Arc length correction**
 For correcting the arc length

V **Welding voltage in V ***

Before the start of welding, the device automatically displays a standard value based on the programmed parameters. The actual value is displayed during welding.

m **Arc-force dynamic**

For influencing the short-circuiting dynamic at the moment of droplet transfer
 - ... harder, more stable arc
 0 ... neutral arc
 + ... soft, low-spatter arc

kJ **Real Energy Input **)**

For displaying the energy applied during the welding operation

*) = Synergic parameter. If one of these parameters is selected in the MIG/MAG standard synergic welding process, then the synergic function ensures that all other synergic parameters are adjusted automatically.

***) This parameter can only be selected if the EnE parameter is set to ON in the Level 2 Setup menu. The value continuously rises during welding in line with the permanently increasing energy yield. The final value at the end of welding remains stored until welding starts again or the power source is switched back on - the HOLD indicator lights up.

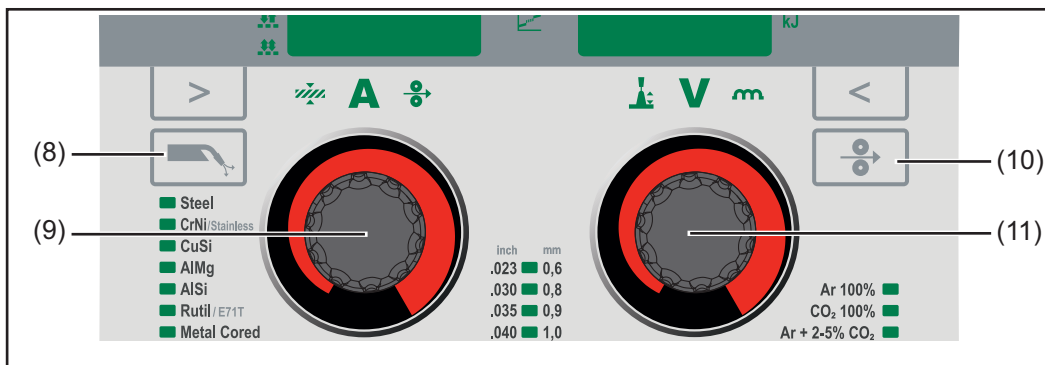

No. Function

(8) Gas-test button

For setting the required gas flow rate on the gas pressure regulator/for filling the torch hosepack with shielding gas.

When the "Gas-test" button is pressed, shielding gas will flow for 30 s. Press the button again to stop the gas flow prematurely.

(9) Adjusting dial (left)

For changing the sheet thickness, welding current and wire speed parameters as well as changing parameters in the Setup menu

(10) "Wire threading" button

For threading the wire into the torch hosepack with no accompanying flow of gas. While the button is being held down, the wire drive runs at feeder inching speed

(11) Adjusting dial (right)

For changing the arc length correction, welding voltage and arc-force dynamic parameters as well as changing parameters in the Setup menu

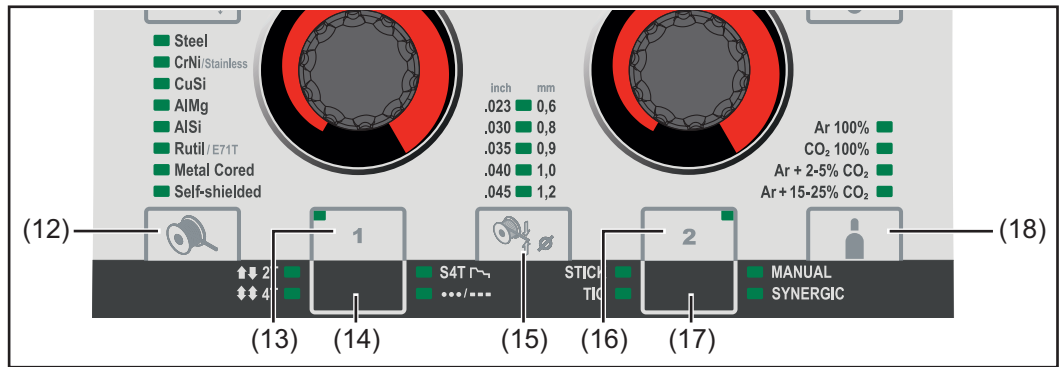

No. Function

(12) "Material" button

For selecting the filler metal to be used

(13) "Save" button 1

For saving an EasyJob

(14) "Mode" button

For selecting the operating mode

- ↑↓ 2 T = 2-step mode
- ⇅ 4 T = 4-step mode
- S4T [Symbol] S 4 T = Special 4-step mode
- .../... Spot welding/stitch welding

(15) "Wire diameter" button

For selecting the wire diameter to be used

(16) "Save" button 2

For saving an EasyJob

(17) "Process" button

- For selecting the welding process
- MANUAL = MIG/MAG standard manual welding
- SYNERGIC = MIG/MAG standard synergic welding
- STICK = Manual metal arc (MMA) welding
- TIG = TIG welding

(18) "Shielding gas" button

For selecting the shielding gas to be used

Keylock

A keylock can be activated to prevent the settings from being inadvertently changed on the control panel. As long as the keylock is active

- Settings cannot be adjusted on the control panel
- Parameter settings can be displayed
- It is possible to switch between EasyJobs if an EasyJob was selected before activating the keylock

Activate/deactivate the keylock as follows:

1 Press and hold the "Mode" button



2 Press and hold the "Mode" button



3 Release the "Mode" and "Parameter selection" buttons

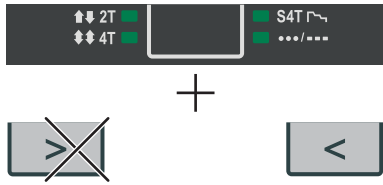

Keylock activated:
The message "CLO | SEd" appears on the displays.

Keylock deactivated:
The message "OP | En" appears on the displays.

Connections, Switches, and Mechanical Components

Safety



WARNING!

Danger from incorrect operation and work that is not carried out properly.

Serious personal injury and damage to property may result.

- ▶ Read and understand this document.
- ▶ Read and understand all the Operating Instructions for the system components, especially the safety rules.

Front and rear of the power source

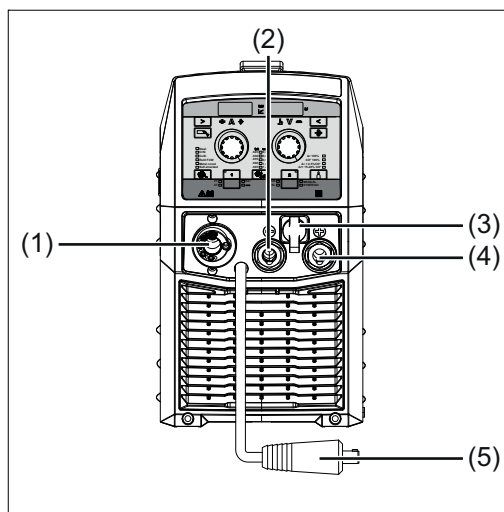

(1) Welding torch connection

For connecting the welding torch

(2) (-) - current socket with bayonet latch

Used for

- Connecting the grounding cable or polarity reverser during MIG/MAG welding (depending on the wire electrode used)
- Connecting the electrode cable or grounding cable during MMA welding (depending on the type of electrode used)
- Connecting the TIG welding torch

(3) TMC connection (TIG Multi Connector)

For connecting the TIG welding torch

(4) (+) - current socket with bayonet latch

Used for

- Connecting the polarity reverser or grounding cable during MIG/MAG welding (depending on the wire electrode used)
- Connecting the electrode cable or grounding cable during MMA welding (depending on the type of electrode used)
- Connecting the grounding cable during TIG welding

(5) Polarity reverser

For selecting the welding potential on the MIG/MAG welding torch

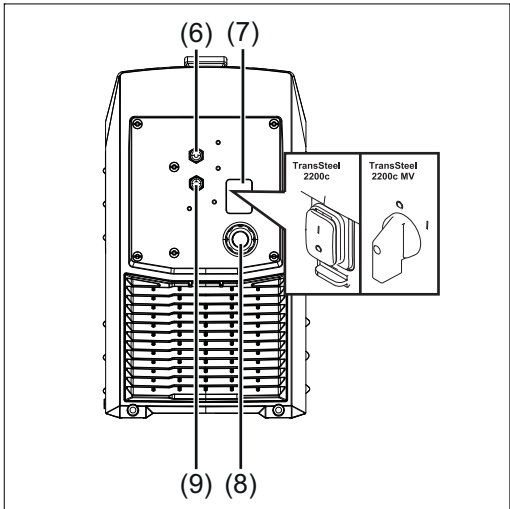

- (6) MIG/MAG shielding gas connection socket**
 For the shielding gas supply to the welding torch connection (1)
- (7) Power switch**
 to switch the power source on and off
- (8) Mains cable with strain relief device**
 Not prefitted on all models
- (9) TIG shielding gas connection**
 For the shielding gas supply to the (-) - current socket (2)

Side view

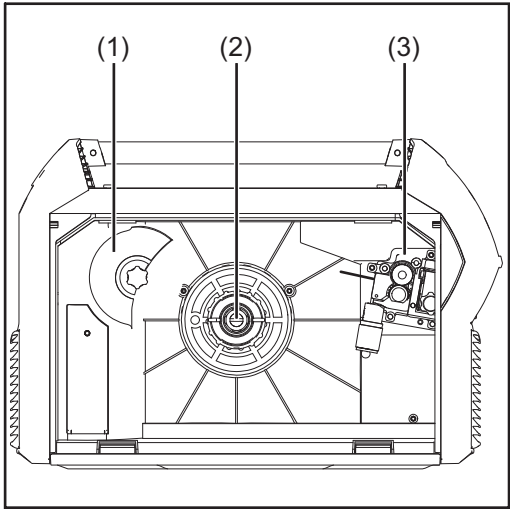

- (1) D100 wire spool holder with brake**
 For holding standard wire spools with a max. diameter of 100 mm (3.94 in)
- (2) D200 wire spool holder with brake**
 For holding standard wire spools with a max. diameter of 200 mm (7.87 in.) and a max. weight of 6.8 kg (14.99 lbs.)
- (3) 2-roller drive**

Before installation and initial operation

Safety



WARNING!

Danger from incorrect operation and work that is not carried out properly.

Serious personal injury and damage to property may result.

- ▶ All the work and functions described in this document must only be carried out by trained and qualified personnel.
- ▶ Read and understand this document.
- ▶ Read and understand all the system component Operating Instructions, especially the safety rules.

Intended use

The power source is intended exclusively for MIG/MAG, rod electrode, and TIG welding. Utilization for any other purpose, or in any other manner, shall be deemed to be not in accordance with the intended purpose.

The manufacturer shall not be held liable for any damages arising from such use.

Intended use also means:

- Following all the instructions in these Operating Instructions
- Carrying out all the specified inspection and maintenance work

Setup regulations

The device has been tested according to degree of protection IP 23. This means:

- Protection against the ingress of solid foreign bodies larger than \varnothing 12 mm (0.49 in.)
- Protection against spraywater up to an inclined angle of 60°

The device can be set up and operated outdoors in accordance with protection class IP 23. Direct moisture (e.g., from rain) must be avoided.



WARNING!

Danger from machines falling or toppling over.

Serious personal injury and damage to property may result.

- ▶ Always place the device on a solid, level surface.



CAUTION!

Danger from electroconductive metallic dust in the device.

The device may be damaged

- ▶ Only operate the device if an air filter is fitted. The air filter is a very important safety device for adhering to IP 23 protection.

The venting duct is a very important safety device. When choosing the device location, ensure that the cooling air can enter and exit unhindered through the air ducts on the front and back of the device. Electroconductive metallic dust (e.g., from grinding work) must not be allowed to get sucked into the device.

Grid Connection

The devices are designed for the grid voltage stated on the rating plate. If the mains cable or mains plug has not been attached to your version of the appliance, these must be installed according to national standards. Fuse protection for the grid lead can be found in the technical data.

NOTE!

An inadequately dimensioned electrical installation can lead to serious damage.
The grid lead and its fuse protection should be designed to suit the existing power supply. The technical data on the rating plate should be followed.

Generator-Powered Operation

Generator-powered operation

The power source is generator-compatible.

The maximum apparent power $S_{1\max}$ of the power source must be known in order to select the correct generator output.

The maximum apparent power $S_{1\max}$ of the power source is calculated as follows:

$$S_{1\max} = I_{1\max} \times U_1$$

$I_{1\max}$ and U_1 according to the device rating plate and technical data

The generator apparent power S_{GEN} needed is calculated using the following rule of thumb:

$$S_{\text{GEN}} = S_{1\max} \times 1.35$$

A smaller generator may be used when not welding at full power.

NOTE!

The generator apparent power S_{GEN} must not be less than the maximum apparent power $S_{1\max}$ of the power source!

When single phase devices are being operated with a 3-phase generator, note that the stated apparent power of the generator is often just the total that can be present across all three phases of the generator. If necessary, obtain further information about the single-phase power of the generator from the generator manufacturer.

NOTE!

The specified voltage of the generator must never fall outside of the mains voltage tolerance range.

The mains voltage tolerance is specified in the "Technical Data" section.

Mains Fuse Protection

Adjustable mains fuse protection

The mains fuse protection selected on the power source limits the power drawn in from the mains and in turn the possible welding current. This prevents the automatic circuit breaker (e.g., in the fuse box) from tripping straight away.

The desired mains fuse protection can be selected on the power source depending on the mains voltage and automatic circuit breaker used.

The following table shows which mains voltages and fuse ratings limit the welding current.

TSt 2200:

Mains voltage	Country-specific setting	Power source fuse rating	Welding current limitation
230 V	Std	10 A	MIG/MAG welding: max. 145 A; 110 A at 100 %* MMA welding: max. 125 A; 90 A at 100 %* TIG welding: max. 180 A; 135 A at 100%*
230 V	Std	13 A	MIG/MAG welding: max. 170 A; 140 A at 100 %* MMA welding: max. 150 A; 120 A at 100 %* TIG welding: max. 200 A; 160 A at 100%*
230 V	Std	16 A	MIG/MAG welding: max. 210 A; 150 A at 100 %* MMA welding: max. 180 A; 130 A at 100 %* TIG welding: max. 230 A; 170 A at 100%*

TSt 2200 MV:

Mains voltage	Country-specific setting	Power source fuse rating	Welding current limitation
120 V	Std	10 A	MIG/MAG welding: max. 100 A; 75 A at 100 %* MMA welding: max. 85 A; 55 A at 100 %* TIG welding: max. 130 A; 95 A at 100%*
120 V	Std	13 A	MIG/MAG welding: max. 105 A; 80 A at 100 %* MMA welding: max. 90 A; 70 A at 100 %* TIG welding: max. 135 A; 105 A at 100%*

TSt 2200 MV:

Mains voltage	Country-specific setting	Power source fuse rating	Welding current limitation
120 V	US	15 A	MIG/MAG welding: max. 105 A; 80 A at 100 %* MMA welding: max. 90 A; 70 A at 100 %* TIG welding: max. 135 A; 105 A at 100%*
120 V	Std	16 A	MIG/MAG welding: max. 115 A; 105 A at 100 %* MMA welding: max. 100 A; 85 A at 100 %* TIG welding: max. 140 A; 130 A at 100%*
120 V	US	20 A	MIG/MAG welding: max. 135 A; 105 A at 100 %* MMA welding: max. 110 A; 90 A at 100 %* TIG welding: max. 160 A; 130 A at 100%*
230 V	Std	10 A	MIG/MAG welding: max. 145 A; 110 A at 100 %* MMA welding: max. 125 A; 90 A at 100 %* TIG welding: max. 180 A; 135 A at 100%*
230 V	Std	13 A	MIG/MAG welding: max. 170 A; 140 A at 100 %* MMA welding: max. 150 A; 120 A at 100 %* TIG welding: max. 200 A; 160 A at 100%*
230 V	Std	16 A	MIG/MAG welding: max. 210 A; 150 A at 100 %* MMA welding: max. 180 A; 130 A at 100 %* TIG welding: max. 230 A; 170 A at 100%*
240 V	US	15 A	MIG/MAG welding: max. 210 A; 150 A at 100 %* MMA welding: max. 180 A; 130 A at 100 %* TIG welding: max. 230 A; 170 A at 100%*

A 20 A fuse can only be selected if:

- The country-specific setting has been set to "US"
- The mains lead has a 20 A fuse
- The power source is supplied with a mains voltage of 120 V

* 100% values = welding with no time limits and without cooling breaks.

The welding current data applies at an ambient temperature of 40°C (104°F).

A safety cut-out prevents the automatic circuit breaker from tripping at higher welding powers. The safety cut-out defines the possible welding duration without the automatic circuit breaker tripping. If the precalculated weld time is exceeded, thus causing the welding cur-

rent to switch off, the service code "toF" is displayed. A countdown immediately appears next to the "toF" indicator, which shows the remaining time until the power source is ready for welding again. After this time, the message disappears and the power source can be used again.

Depending on the selected fuse, the safety cut-out limits the maximum currents of the selected process. As a result, it is possible that welding can no longer occur at the saved operating points if these were saved before selecting the fuse.

If welding is nevertheless carried out at one of these operating points, the power source operates at the limit value of the selected fuse – the power limitation is active. The operating point should be re-saved in accordance with the power limitation.

Carrying Strap Option

Fitting the Carrying Strap

Fitting the carrying strap to the power source

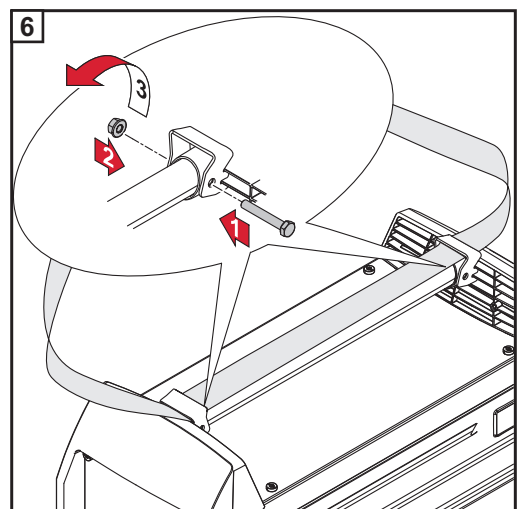
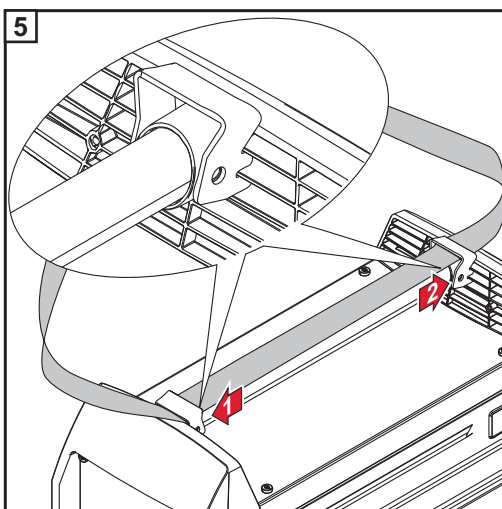
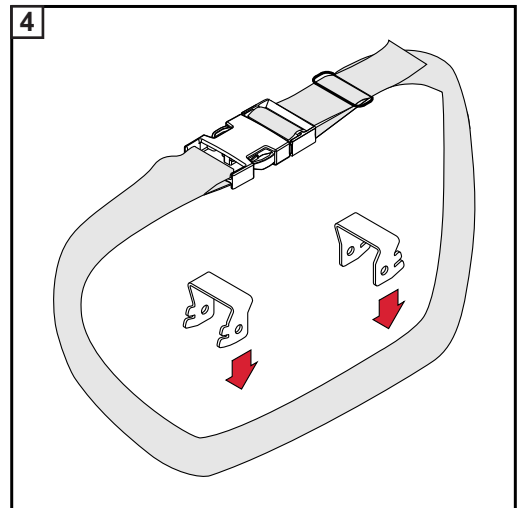
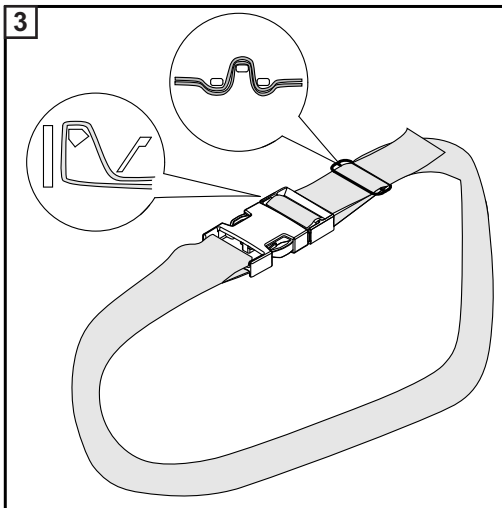
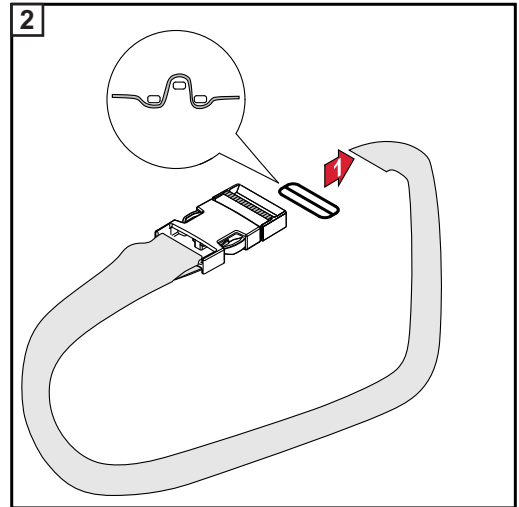
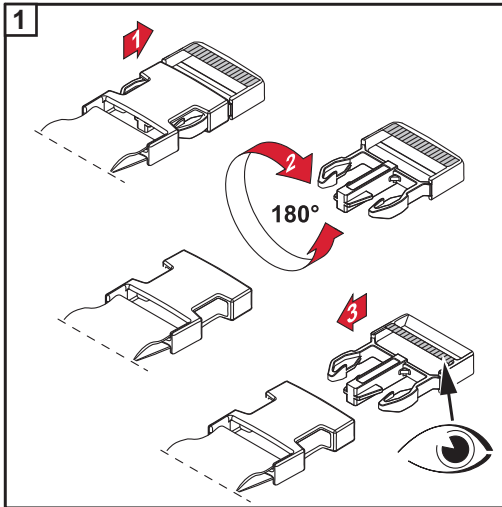

MIG/MAG

Commissioning

Connecting a MIG/MAG welding torch

- 1 Before connecting the welding torch to the power source, equip the welding torch according to the welding torch Operating Instructions: Fit wearing parts to the torch body, fit the inner liner.

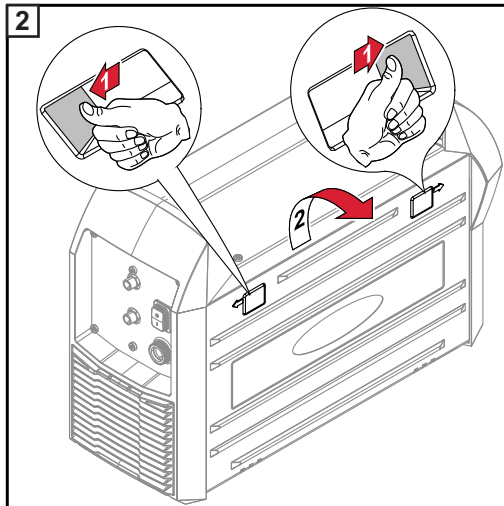

- 3 Unscrew the knurled screw (1) slightly so that the welding torch can be easily pushed into the welding torch connection.

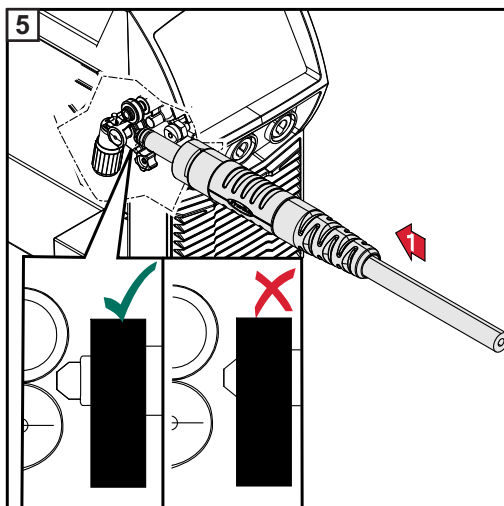
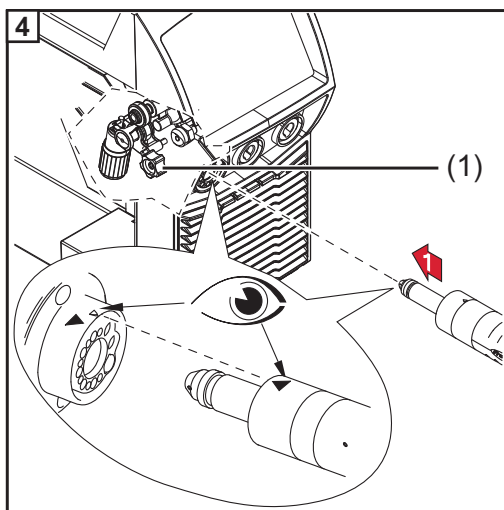

⚠ CAUTION!

Risk of damage if the welding torch is not fully inserted.

The device may be damaged.

- After inserting the welding torch, ensure it is in the end position shown.

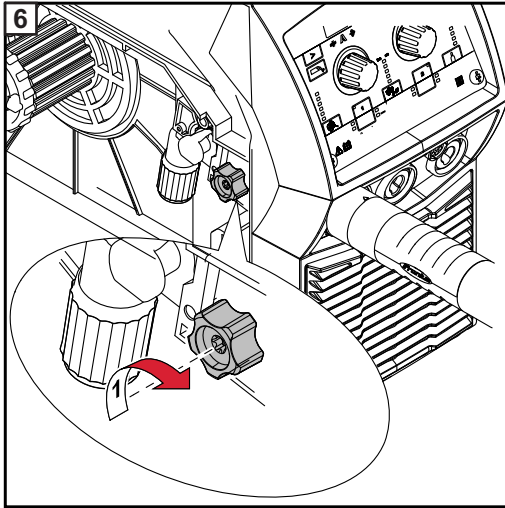

Inserting the feed rollers

In order to achieve optimum wire electrode feed, the feed rollers must be suitable for the diameter and alloy of the wire being welded.

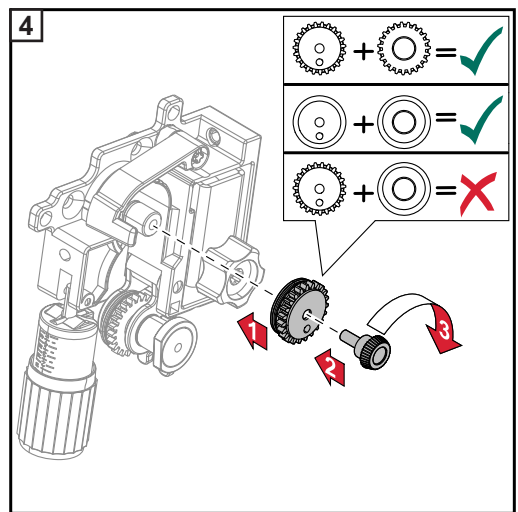
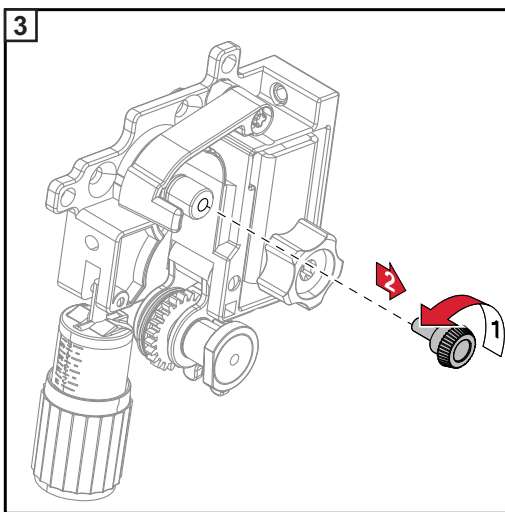
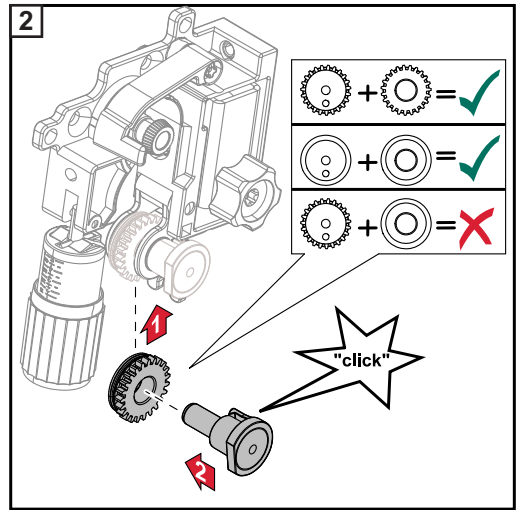
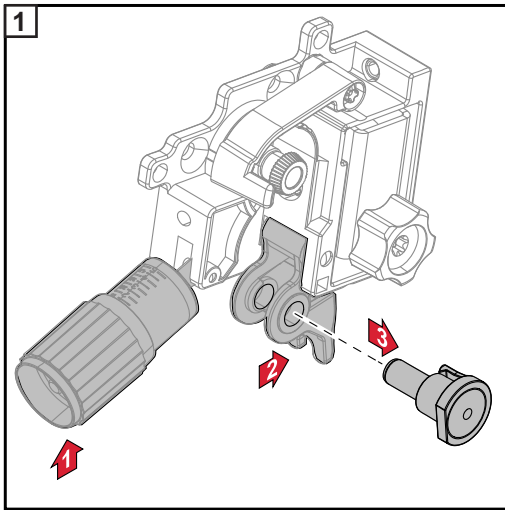

Inserting the D100 wirespool

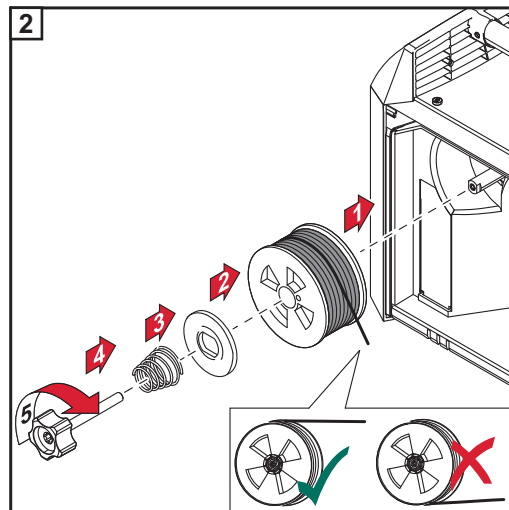
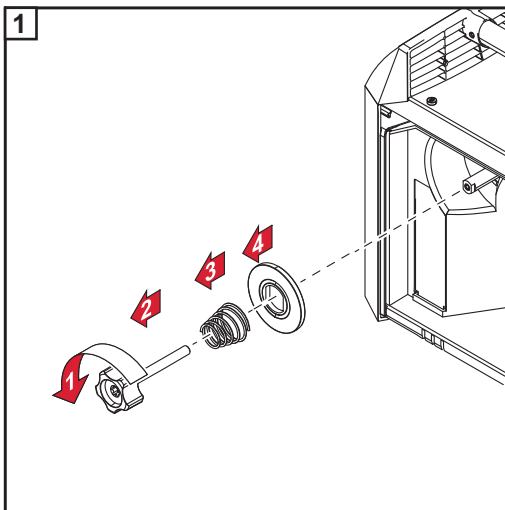

Inserting the D200 wirespool

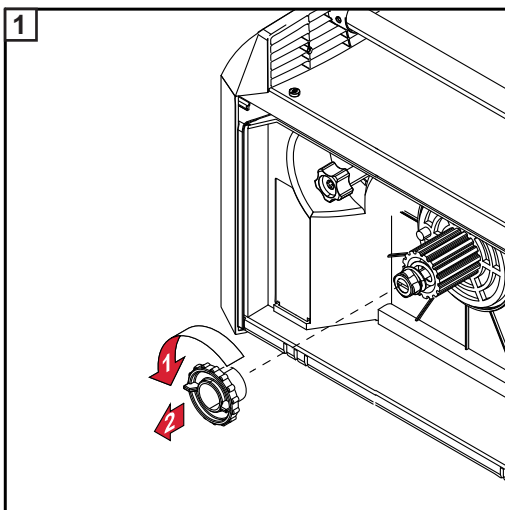

⚠ CAUTION!

Danger from placing the locking ring the wrong way round.
Personal injury and damage to property may result.
▶ Always position and tighten the locking ring as shown below.

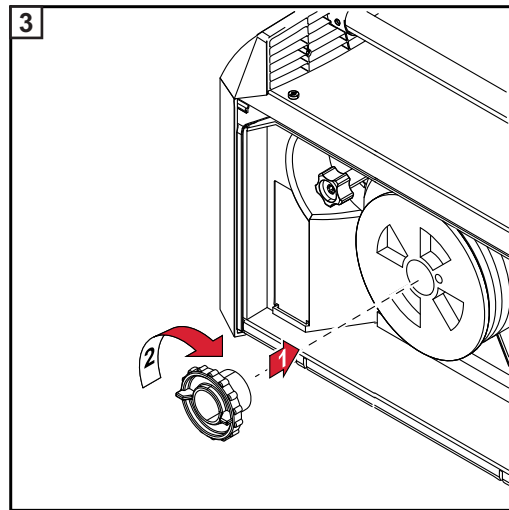
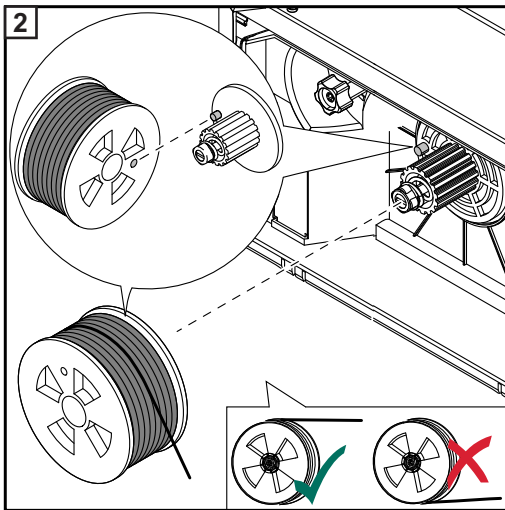

Feeding in the wire electrode

CAUTION!

Danger from springiness of spooled wire electrode.

It can cause injuries.

- ▶ When inserting the wire electrode into the wire drive, hold the end of the wire electrode firmly.

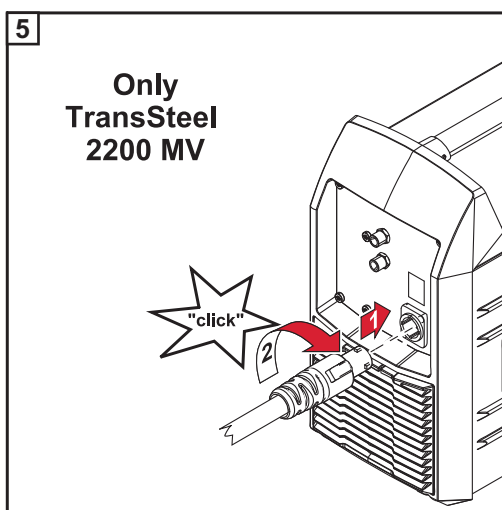
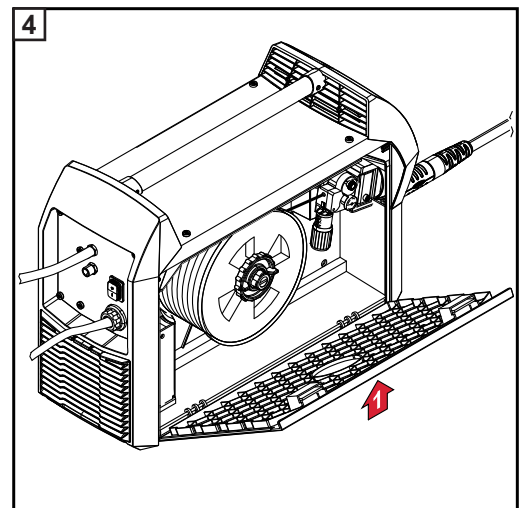
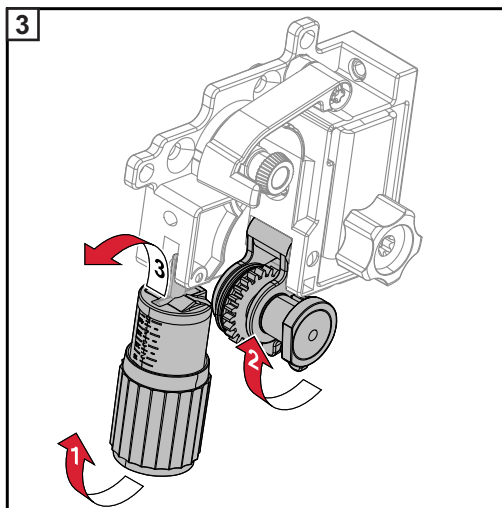
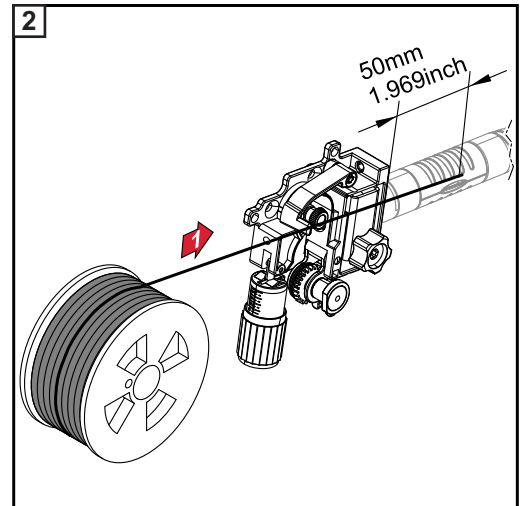
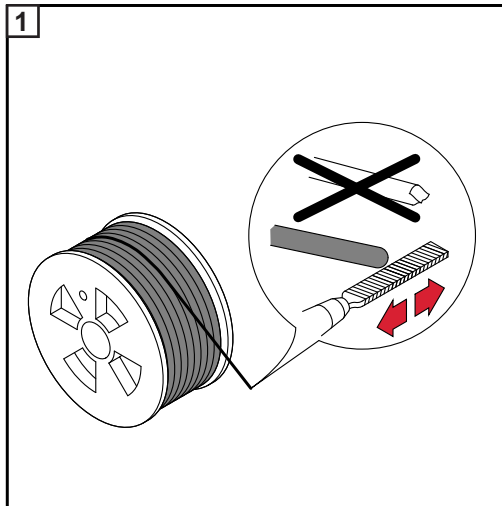

It is only necessary to connect the mains cable to the power source for multivoltage power sources.

⚠ CAUTION!

Danger from wire electrode emerging unexpectedly as it is being threaded.

It can cause injuries.

- ▶ Wear suitable protective goggles
- ▶ Keep the tip of the welding torch away from your face and body
- ▶ Do not point the tip of the welding torch at people
- ▶ Make sure that the wire electrode does not touch any conductive or earthed parts (e.g., housing)

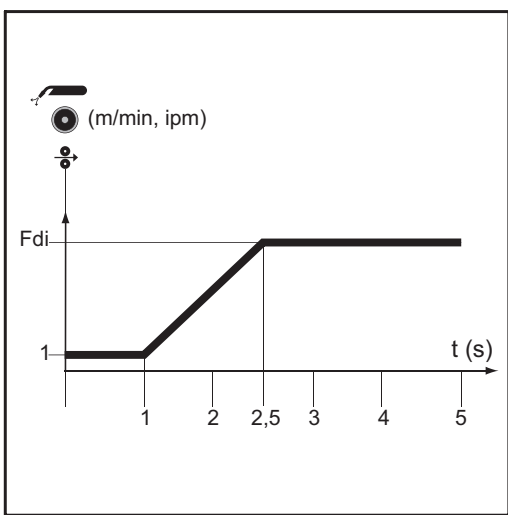
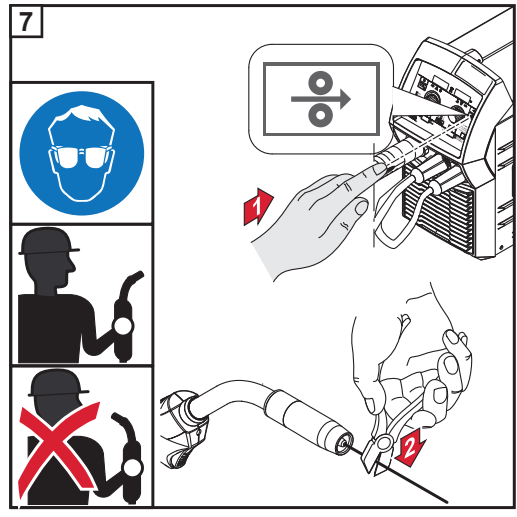
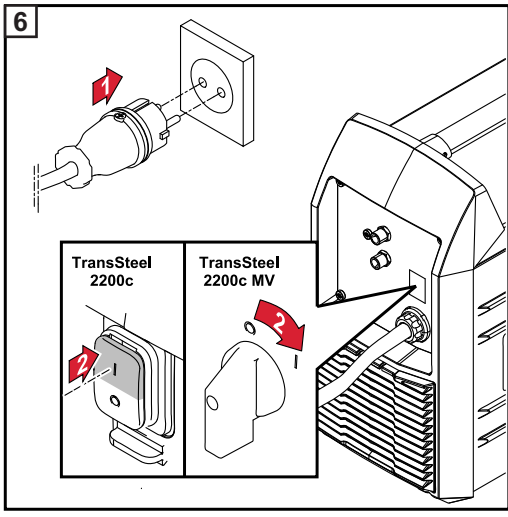

Wire threading process (press the "Wire threading" button on the control panel):

- Hold down the button for up to **one second** (briefly press the button): the wire speed stays at 1 m/min (39.37 ipm) for the first second
- Hold down the button for up to **2.5 seconds**: after one second, the wire speed increases over the next 1.5 seconds.
- Hold down the button for **longer than 2.5 seconds**: after 2.5 seconds, the wire is fed at a constant rate equal to the wire speed set for the Fdi welding parameter.

Setting the contact pressure

- 1** Adjust the contact pressure as shown in the following tables
- Doing so will prevent deformation of the wire electrode and ensure that the wire is transported properly

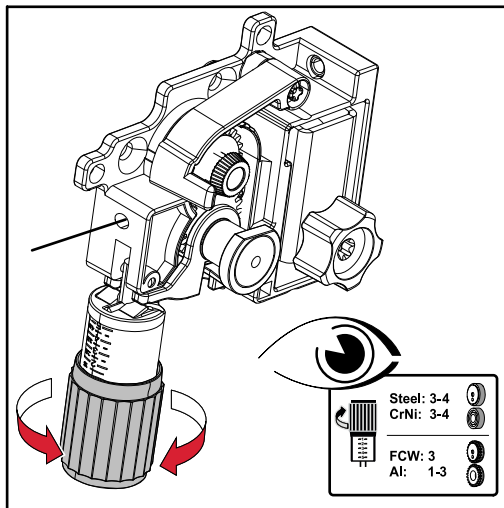

Standard values for contact pressure with smooth feed rollers:

- Steel = 3 - 4
- CrNi = 3 - 4

Standard values for contact pressure with toothed feed rollers:

- Tubular covered electrodes = 3
- Aluminum = 1 - 3

Connecting the gas cylinder

WARNING!

Danger from gas cylinders falling over.

Serious personal injury and damage to property may result.

- ▶ Place the gas cylinders on a level and stable surface.
- ▶ Secure the gas cylinders to prevent them from falling over
- ▶ Observe the safety rules of the gas cylinder manufacturer.

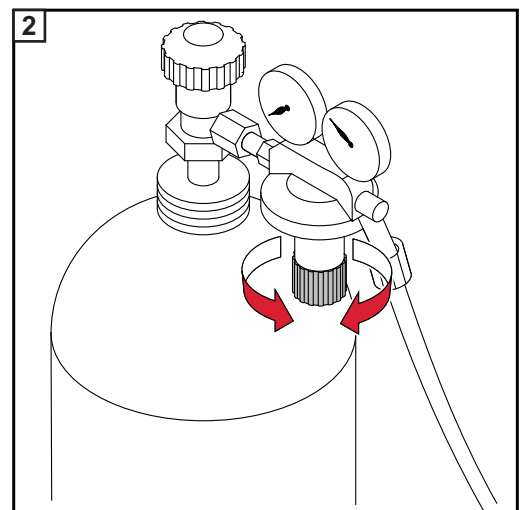
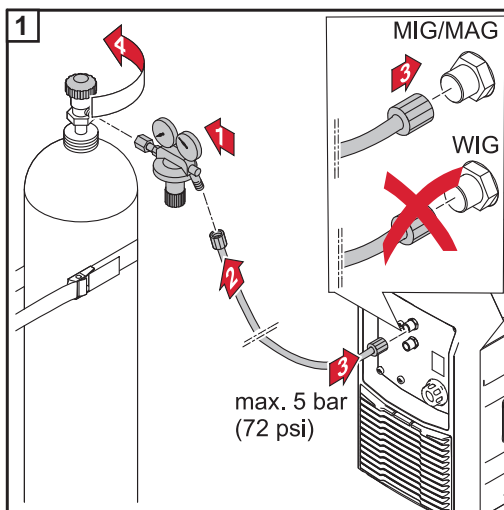

Connecting the polarity reverser and establishing a grounding (earthing) connection

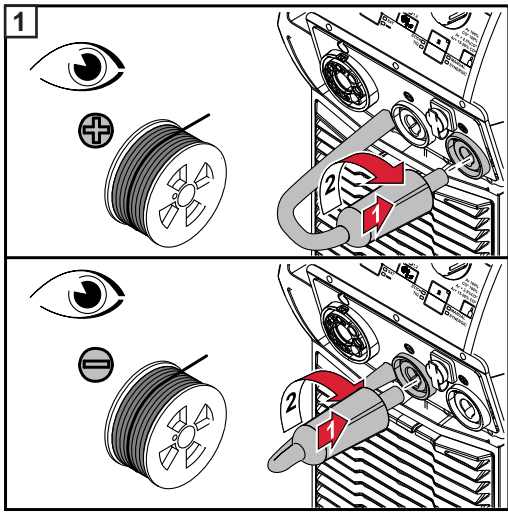

NOTE!

Risk from incorrectly connected polarity reverser.

This can result in poor-quality weld properties.

- ▶ Connect the polarity reverser according to the wire electrode used. Check the wire electrode packaging to determine whether the wire electrode is for (+) or (-) welding

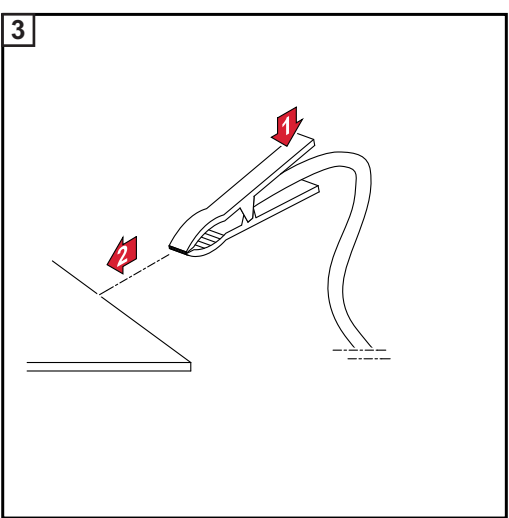
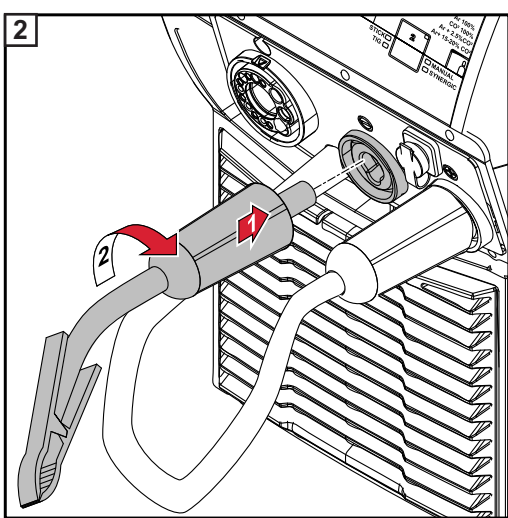

Adjusting the Brake of the Wirespool Holders

General

D200 wirespool holder:

Adjust the brake when using the wirespool holder for the first time and after changing the wirespool. To do so, proceed as described in the following section "Adjusting the brake of the D200 wirespool holder".

D100 wirespool holder:

Adjust the brake when using the wirespool holder for the first time and after changing the wirespool. To do so, proceed as described in the following section "Adjusting the brake of the D100 wirespool holder".

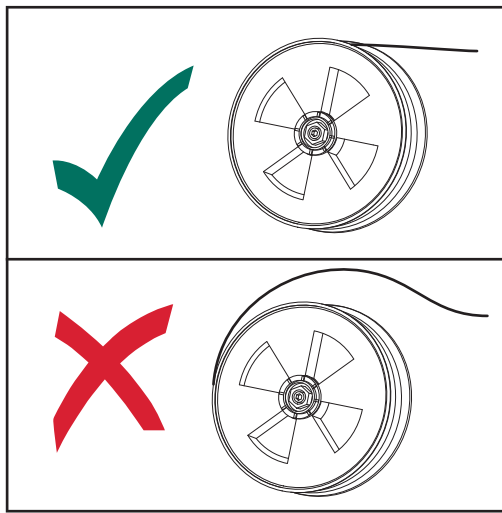

After releasing the torch trigger (end of welding, end of wirefeeding), the wirespool must stop unreeeling. If it fails to do so, adjust the brake.

Adjusting the brake of the D200 wirepool holder

⚠ CAUTION!

Danger from emerging wire electrode and moving parts.

Personal injury and damage to property may result.

- ▶ Before starting work, turn the mains switch of the power source to - O - and disconnect the power source from the mains
- ▶ Secure all devices and components involved so they cannot be switched back on.

Adjust the brake:

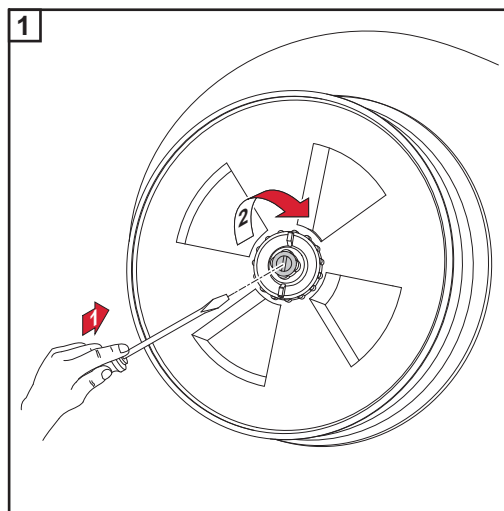

- Turn the brake to the right = increase braking force
- Turn the brake to the left = decrease braking force

Adjusting the brake of the D100 wirepool holder

⚠ CAUTION!

Danger from emerging wire electrode and moving parts.

Personal injury and damage to property may result.

- ▶ Before starting work, turn the mains switch of the power source to - O - and disconnect the power source from the mains
- ▶ Secure all devices and components involved so that they cannot be switched back on.

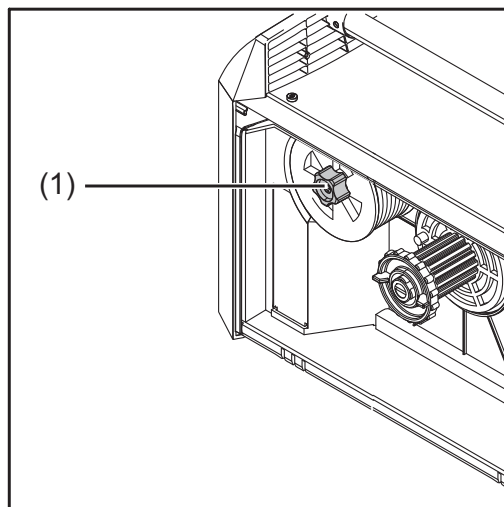

Adjust the brake:

- 1** Tighten the knurled screw (1)
 - Knurled screw fully tightened = high braking force
 - Knurled screw slightly tightened = low braking force

Description of MIG/MAG Operating Modes

2-step mode

"2-step mode" is suitable for

- Tacking work
- Short weld seams

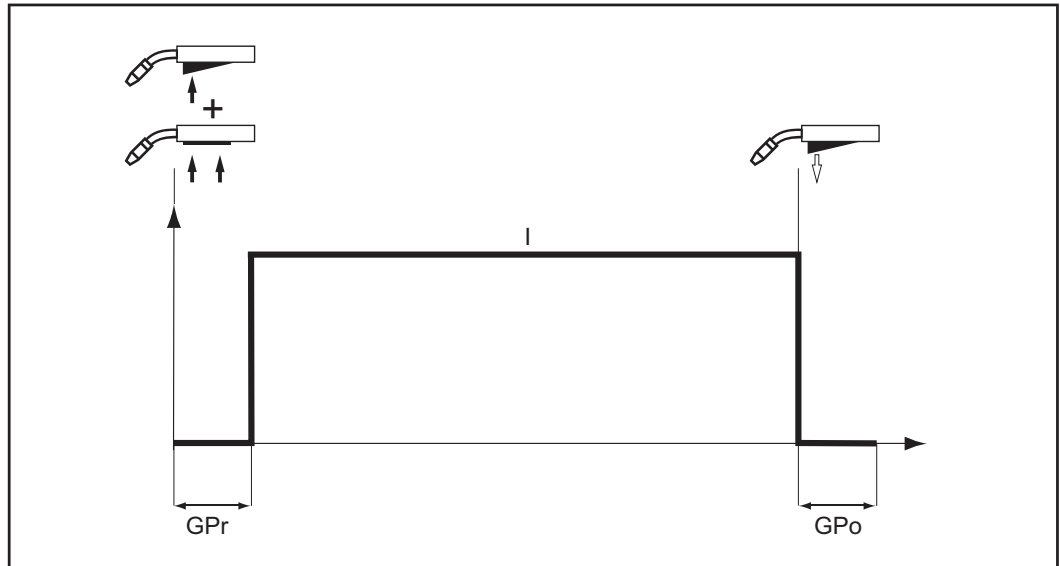

2-step mode

Explanation of symbols:



Press the torch trigger

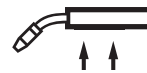

Hold the torch trigger

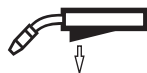

Release the torch trigger

Abbreviations used

GPr Gas pre-flow time

I Welding current

GPo Gas post-flow time

4-step mode

"4-step mode" is suitable for longer weld seams.

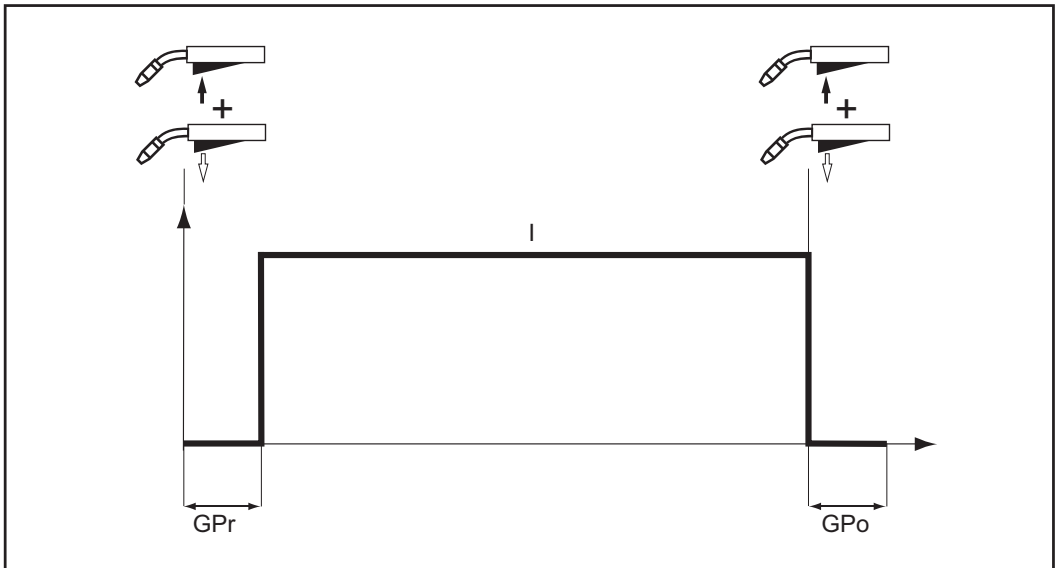

4-step mode

Explanation of symbols:

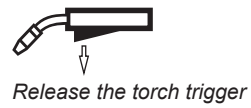
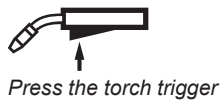

Abbreviations used

- GPr Gas pre-flow time
- I Welding current
- GPo Gas post-flow time

Special 4-step mode

"Special 4-step mode" is ideal for welding in higher power ranges. In special 4-step mode, the arc starts at a low power, which makes it easier to stabilize.

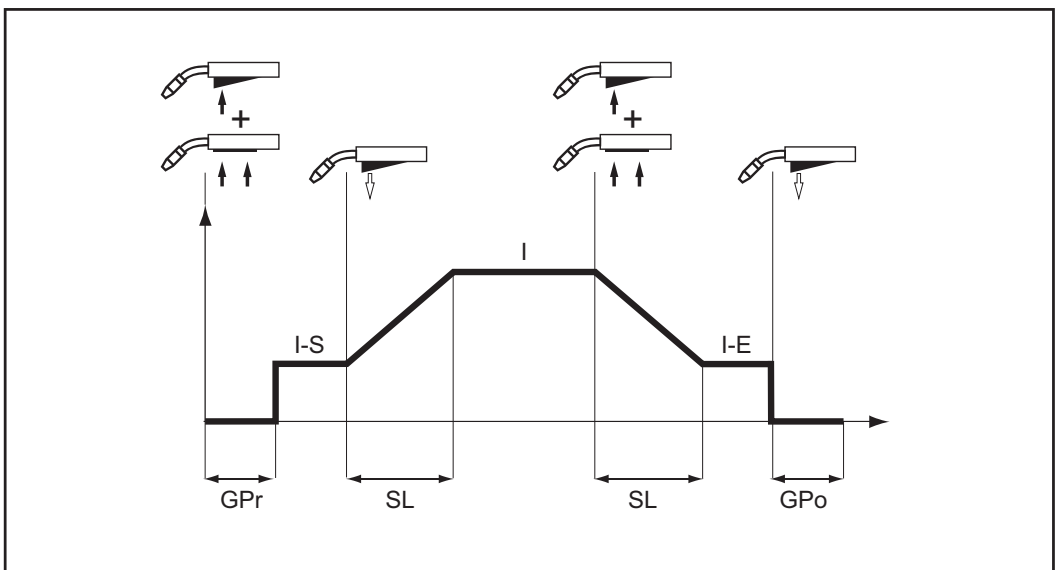

Special 4-step mode

Explanation of symbols:

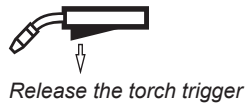
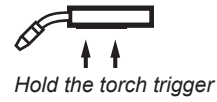
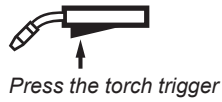

Abbreviations used

- GPr Gas pre-flow time
- I-S Starting current
- SL Slope: continuous increasing / lowering of welding current
- I Main current
- I-E Final current
- GPo Gas post-flow time

Spot welding

The "Spot welding" mode is suitable for welded joints on overlapped sheets.

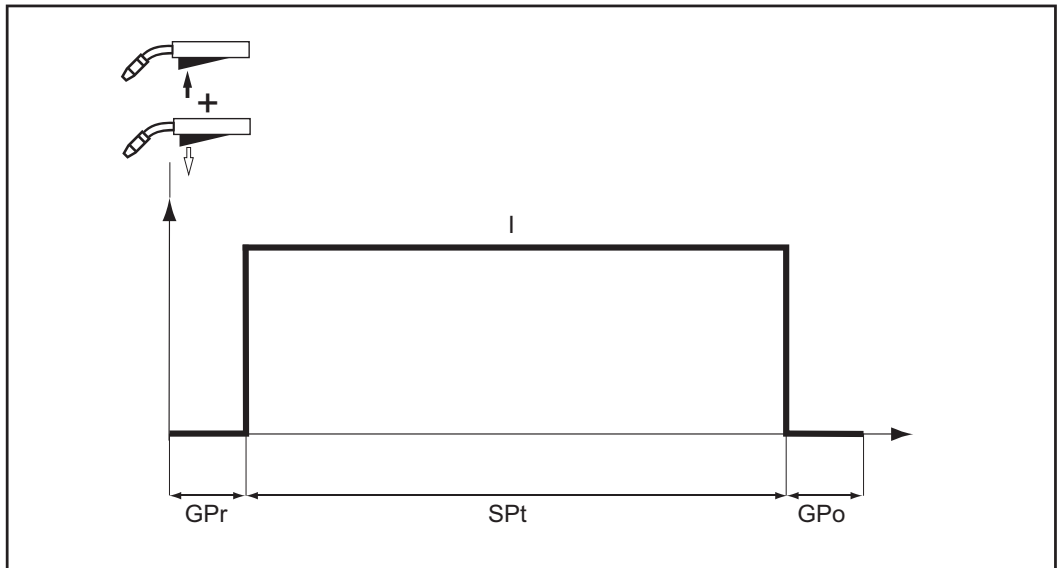

Spot welding

Explanation of symbols:

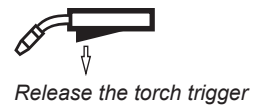
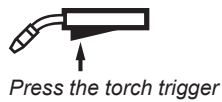

Abbreviations used

- GPr Gas pre-flow time
- I Welding current
- SPt Spot welding time / interval welding time
- GPo Gas post-flow time

2-step stitch welding

The "2-step stitch welding" mode is suitable for welding short weld seams on thin sheets, to prevent the weld seams from dropping through the base material.

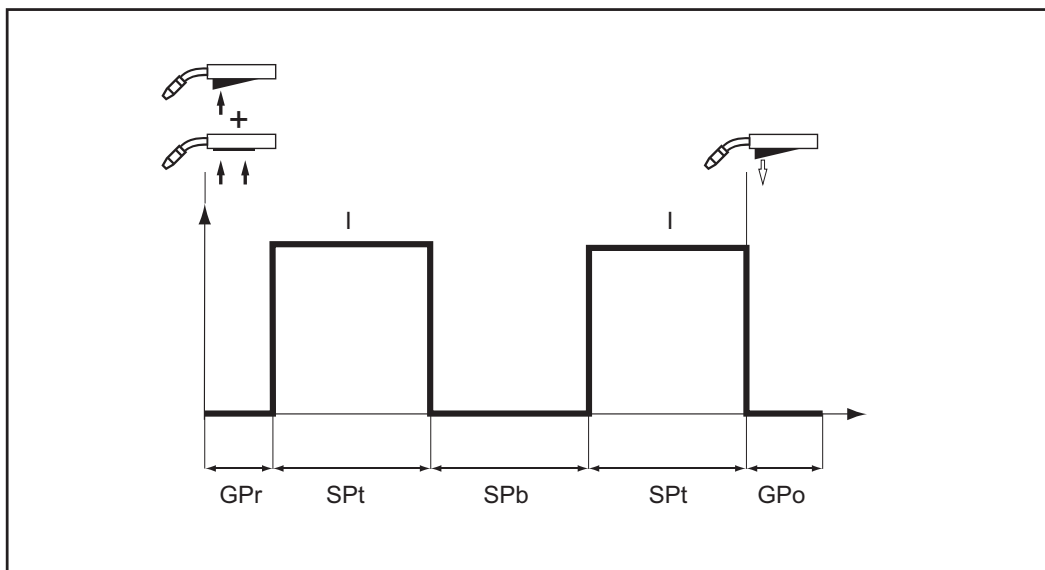

2-step stitch welding

Explanation of symbols:

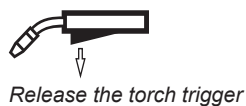
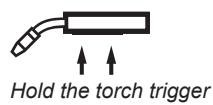
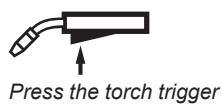

Abbreviations used

- GPr Gas pre-flow time
- I Welding current
- SPt Spot welding time / interval welding time
- SPb Interval pause time
- GPo Gas post-flow time

4-step stitch welding

The "4-step stitch welding" mode is suitable for welding longer weld seams on thin sheets, to prevent the weld seams from dropping through the base material.

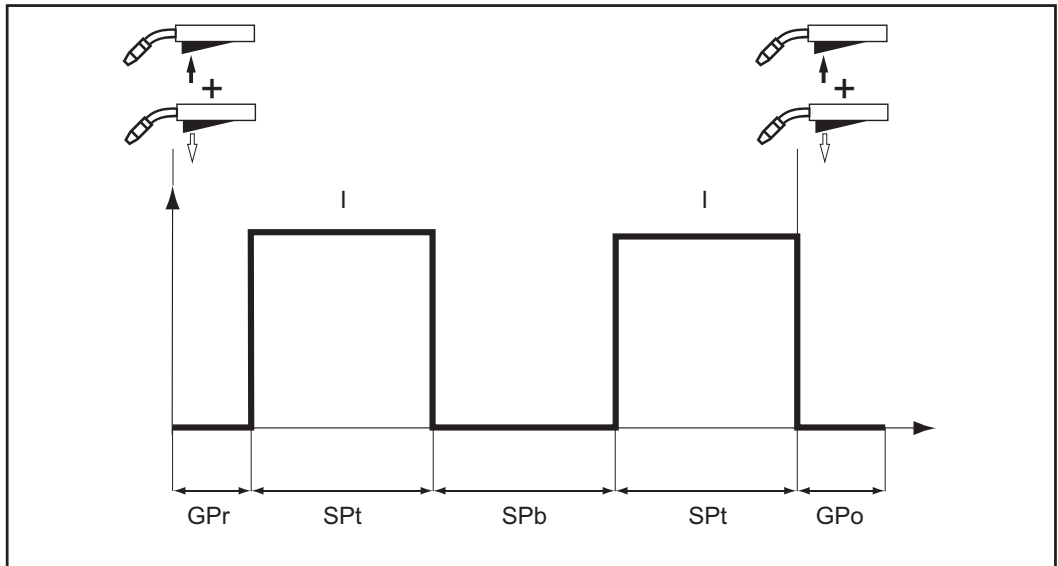

4-step stitch welding

Explanation of symbols:



Press the torch trigger

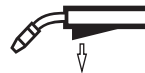

Release the torch trigger

Abbreviations used

GPr Gas pre-flow time

I Welding current

SPt Spot welding time / interval welding time

SPb Interval pause time

GPo Gas post-flow time

MIG/MAG Standard Manual Welding

General

The MIG/MAG standard manual welding process is a MIG/MAG welding process with no synergic function.

Changing one parameter does not result in any automatic adjustments to the other parameters – all variable parameters must be adjusted individually.

Available parameters

The following parameters are available for MIG/MAG manual welding:

-  Wire speed
- V** Welding voltage
- m** Arc-force dynamic - for influencing the short-circuiting dynamic at the instant of droplet transfer
- A** Welding current (only the actual value is displayed)

MIG/MAG standard manual welding



- 1 Press the "Process" button to select MANUAL



- 2 Press the "Mode" button



to select the desired MIG/MAG mode:

-  2-step mode
-  4-step mode
-  Spot welding/stitch welding

- 3 Select and set the wire speed parameter
- 4 Select and set the welding voltage parameter

All parameter set values remain stored until the next time they are changed. This applies even if the power source is switched off and on again.

- 5 Ensure that the grounding (earthing) connection has been established
- 6 Ensure that the shielding gas supply has been established
 - Power source is ready for welding

Corrections during welding

The arc-force dynamic parameter can be used to optimize the welding result.

The arc-force dynamic parameter is used to influence the short-circuiting dynamic at the moment of droplet transfer:

- = hard, stable arc
- 0 = neutral arc
- + = soft, low-spatter arc

MIG/MAG Standard Synergic Welding

MIG/MAG standard synergic welding

- 1 Press the "Process" button to select SYNERGIC



- 2 Press the "Mode" button



to select the desired MIG/MAG mode:

- ↑↓ 2-step mode
- ⇅ 4-step mode
- S4T S 4 T - Special 4-step mode
- .../... Spot welding/stitch welding

Under certain circumstances, it may not be possible to change welding parameters that have been set for a system component (remote control, etc.) on the control panel of the power source.

- 3 Press the "Material" button to select the filler metal to be used
- 4 Press the "Wire diameter" button to select the diameter of the wire electrode used
- 5 Press the "Shielding gas" button to select the shielding gas used
- 6 Use the "Parameter selection" buttons to select and set the welding parameters to be used to specify the welding power:
 - Sheet thickness
 - A Welding current
 - ⊗ Wire speed
 - V Welding voltage

All parameter set values remain stored until the next time they are changed. This applies even if the power source is switched off and on again.

- 7 Ensure that the grounding (earthing) connection has been established
- 8 Ensure that the shielding gas supply has been established
 - Power source is ready for welding

Corrections during welding

The arc length correction and arc-force dynamic parameters can be used to optimize the welding result.

Arc length correction:

- = shorter arc, reduced welding voltage
- 0 = neutral arc
- + = longer arc, increased welding voltage

Arc-force dynamic:

For influencing the short-circuiting dynamic at the instant of droplet transfer

- = hard, stable arc
- 0 = neutral arc
- + = soft, low-spatter arc

Spot and Stitch Welding

General

The spot and stitch welding modes are MIG/MAG welding processes.

Spot welding is used on welded joints on overlapping sheets that are only accessible on one side.

Stitch welding is used for light-gage sheets.

As the wire electrode is not fed continuously, the weld pool can cool down during the intervals. Local overheating leading to the parent material being melted through is largely avoided.

Spot welding

- 1 Press the "Process" button to select MANUAL or SYNERGIC
 - 2 Press the "Mode" button to select the spot welding/stitch welding mode:
.../... = spot welding/stitch welding
 - 3 Set the SPt parameter in the Setup menu (spot welding time/interval welding time) to the desired value
 - 4 Set the desired parameters depending on the process (MANUAL or SYNERGIC)
 - 5 Ensure that the grounding (earthing) connection has been established
 - 6 Ensure that the shielding gas supply has been established
 - Power source is ready for welding
-

Stitch welding

- 1 Press the "Process" button to select MANUAL or SYNERGIC
- 2 Press the "Mode" button to select the spot welding/stitch welding mode:
.../... = spot welding/stitch welding
- 3 Set the SPt parameter in the Setup menu (spot welding time/interval welding time) to the desired value
- 4 Set the SPb parameter in the Setup menu (spot welding/stitch pause time) to the desired value
- 5 Set the Int parameter in the Setup menu (interval) to the desired value
- 6 Set the desired parameters depending on the process (MANUAL or SYNERGIC)
- 7 Ensure that the grounding (earthing) connection has been established
- 8 Ensure that the shielding gas supply has been established
 - Power source is ready for welding

TIG

Commissioning

Start-Up

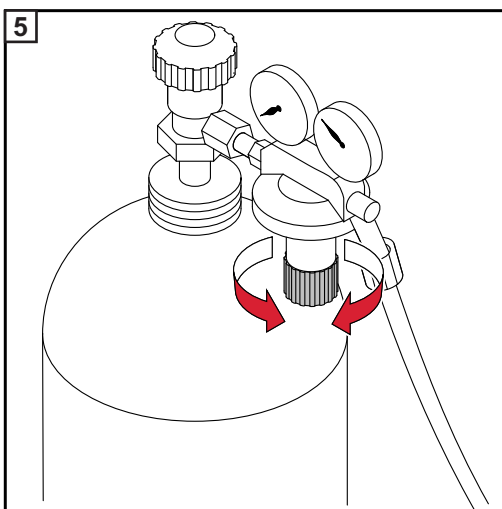
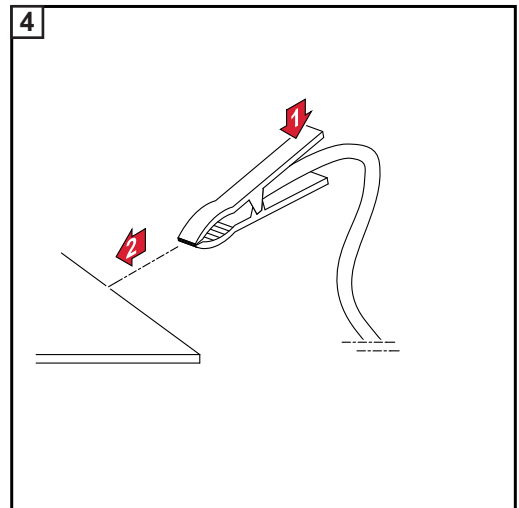
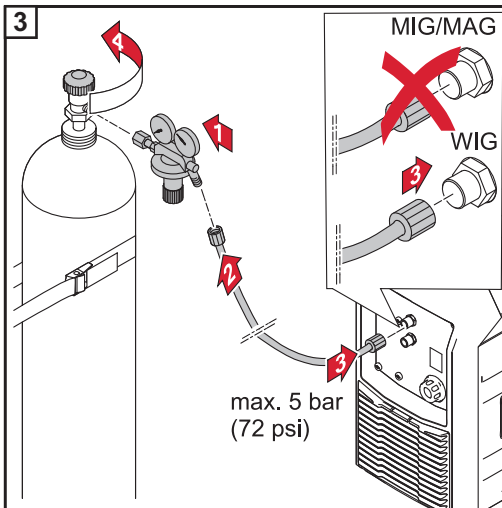
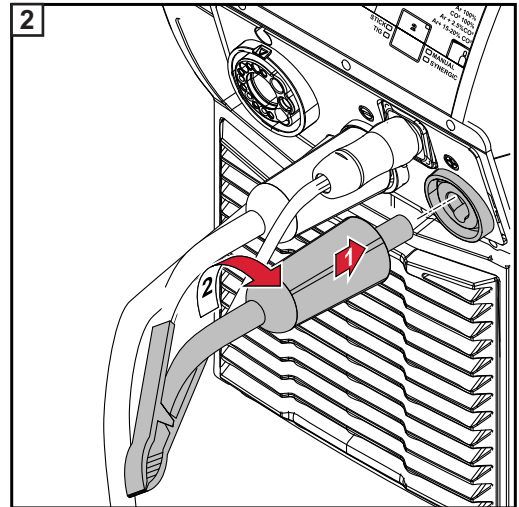
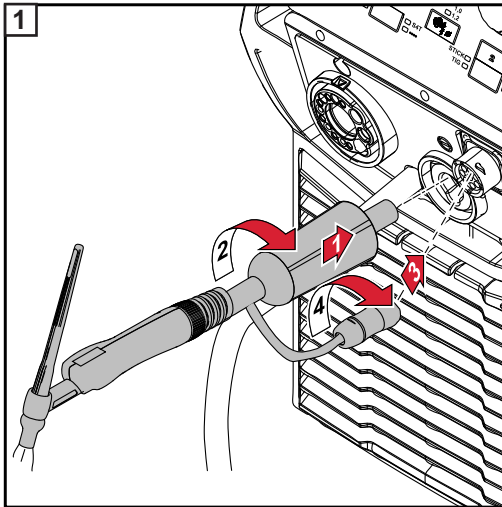

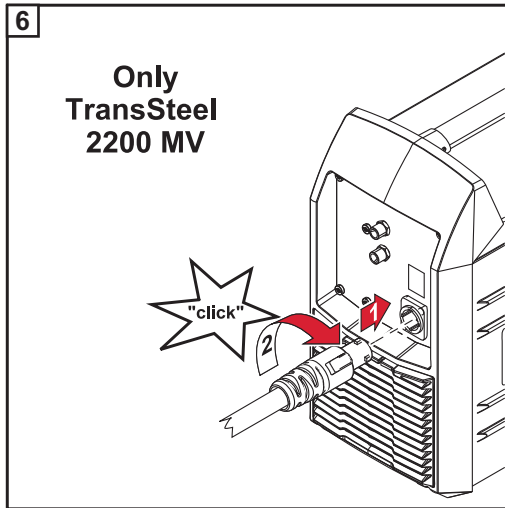

It is only necessary to connect the mains cable to the power source for multivoltage power sources.

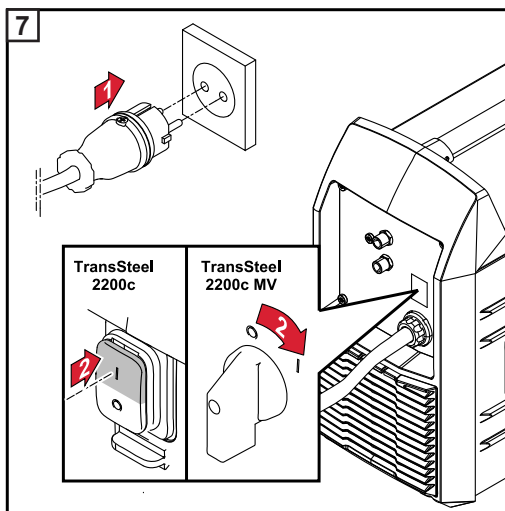

⚠ CAUTION!

Danger due to welding processes starting unintentionally.

Personal injury and damage to property may result.

- ▶ As soon as the power source is switched on, ensure that the tungsten electrode does not accidentally, or in an uncontrolled manner, touch any electrically conductive or grounded parts (e.g., the housing, etc.).

TIG welding

- 1 Press the "Process" button to select TIG
- 2 Set the desired welding current

When using a welding torch with a torch trigger and TIG Multi Connector plug (with 2-step mode factory setting):

- 3 Place the gas nozzle down on the ignition location in such a way that there is a gap of approx. 2 to 3 mm (0.078 to 0.118 in.) between the tungsten electrode and the workpiece
- 4 Gradually tilt the welding torch up until the tungsten electrode touches the workpiece
- 5 Pull back the torch trigger and hold it in this position
 - Shielding gas flows
- 6 Raise the welding torch and rotate it into its normal position
 - The arc ignites
- 7 Carry out welding

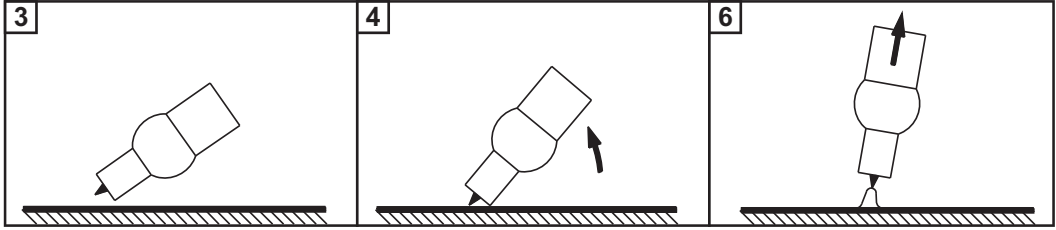

Description of TIG Operating Modes

2-step mode

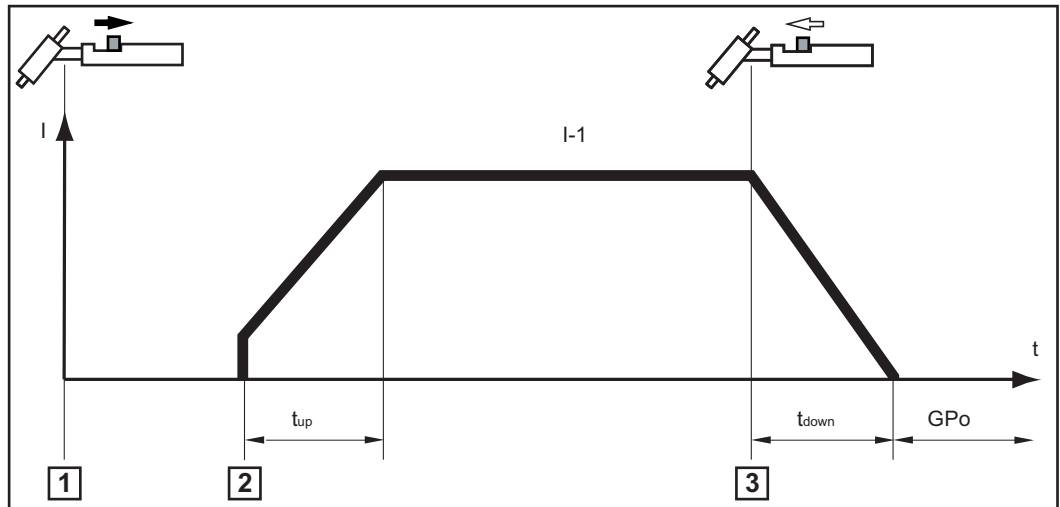

Welding in 2-step mode:

- 1** Place the tungsten electrode onto the workpiece and then pull the torch trigger back and hold => shielding gas flows
- 2** Raise the tungsten electrode => arc ignites
- 3** Release torch trigger => end of welding

Explanation of symbols:

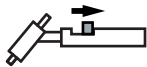

Pull back the torch trigger and hold it in this position

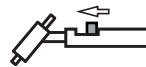

Release the torch trigger forwards

Abbreviations used

GPO Gas post-flow time

t_{up} UpSlope phase: the welding current is continually increased
Duration: 0.5 seconds

t_{down} DownSlope phase: the welding current is continuously reduced
Duration: 0.5 seconds

4-Step Mode

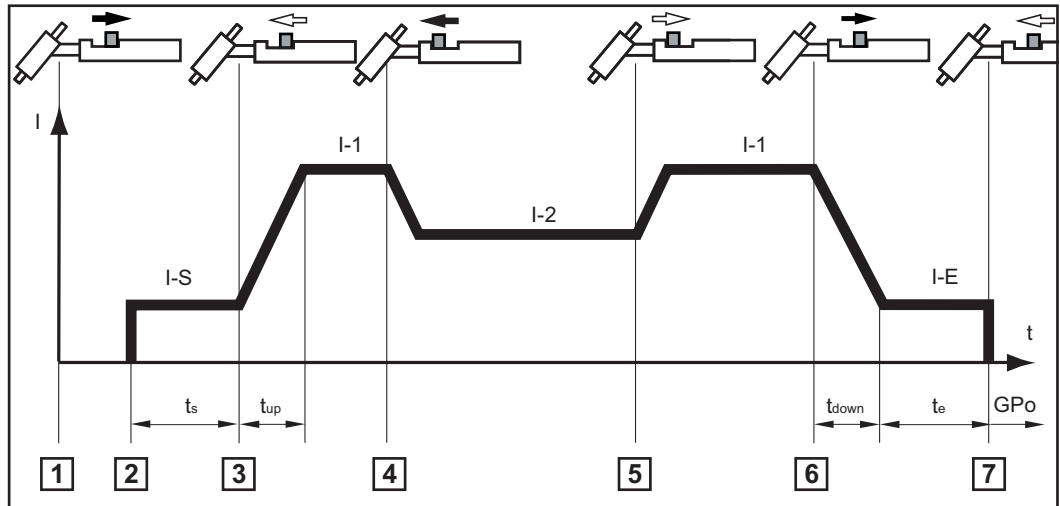

4-step mode with intermediate lowering I-2

Intermediate lowering means that the welder uses the torch trigger during the main current phase to lower the welding current to the specified reduced current I-2.

Welding with 4-step mode:

- 1 Place the tungsten electrode onto the workpiece and then pull the torch trigger back and hold => shielding gas flows
- 2 Raise the tungsten electrode => start of welding with starting current I-S
- 3 Release torch trigger => welding with main current I-1
- 4 Push forward and hold the torch trigger => activation of intermediate lowering with reduced current I-2
- 5 Release torch trigger => welding with main current I-1
- 6 Pull back and hold the torch trigger => lowering to final current I-E
- 7 Release torch trigger => end of welding

Explanation of symbols:

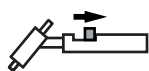

Pull back the torch trigger and hold it in this position

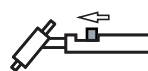

Release the torch trigger forwards

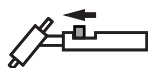

Pull back the torch trigger and hold it in this position

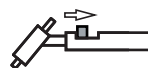

Release the torch trigger forwards

Abbreviations used:

- GPo Gas post-flow time
- I-S Starting-current phase: the temperature is raised gently at low welding current, so that the filler metal can be positioned correctly
- I-1 Main current phase (welding current phase): uniform thermal input into the parent material, whose temperature is raised by the advancing heat
- I-E Final current phase: to prevent crater cracks or shrink holes
- I-2 Reduced current phase: intermediate lowering of the welding current in order to prevent any local overheating of the parent material
- t_s Starting current duration

t_{up}	UpSlope phase: the welding current is continually increased Duration: 0.5 seconds
t_E	Final current duration
t_{down}	DownSlope phase: the welding current is continuously reduced Duration: 0.5 seconds

Pulse Welding

Applications

Pulse welding is welding with a pulsing welding current. It is used to weld steel pipes out-of-position or to weld thin sheet metal.

In these applications, the welding current set at the start of welding is not always optimum for the entire welding process:

- If the amperage is too low, the parent material will not be melted enough
- If overheating occurs, there is a danger that the liquid weld pool may drip

Operating Principle

- A low base current I-G rises steeply to the significantly higher pulse current I-P and drops back to the base current I-G after the time Duty cycle dcY.
- This results in an average current that is lower than the set pulse current I-P.
- During pulse welding, small sections of the welding location melt quickly and then rapidly re-solidify.

The power source controls the Duty cycle dcY parameter and base current I-G according to the set pulse current (welding current) and pulse frequency.

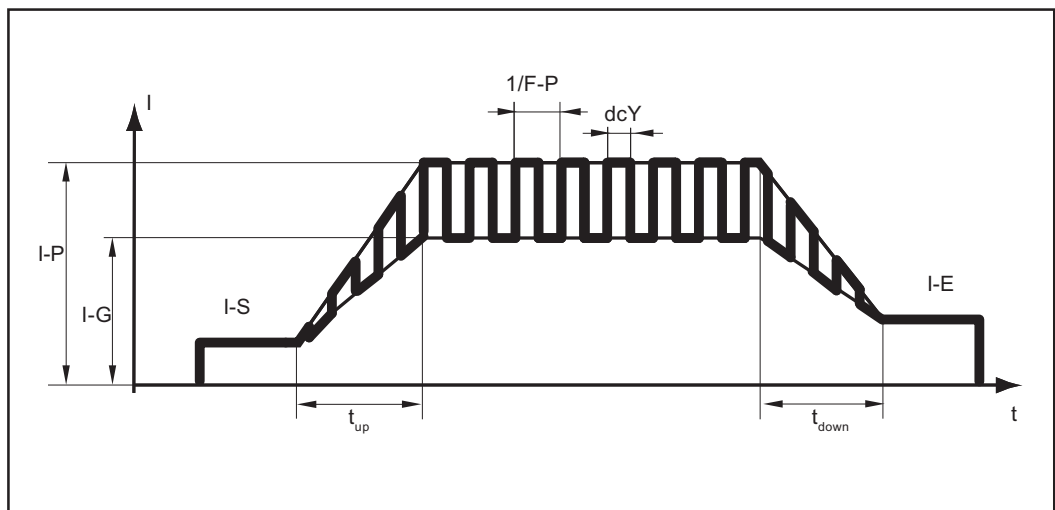

Welding current progression curve

Adjustable parameters:

I-S Starting current

I-E Final current

F-P Pulse frequency ($1/F-P = \text{Time between two pulses}$)

I-P Pulse current (set welding current)

Fixed parameters:

t_{up} UpSlope

t_{down} DownSlope

dcY Duty cycle

I-G Base current

**Activating Pulse
Welding**

- 1** Set a value for the F-P setup parameter (pulse frequency)
- Setting range: 1 - 990 Hz

Rod Electrode

Commissioning

Preparation

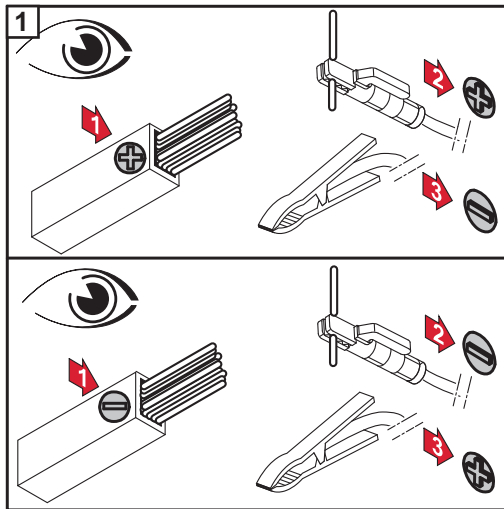

Check the rod electrode packaging to determine whether the rod electrode is for (+) or (-) welding

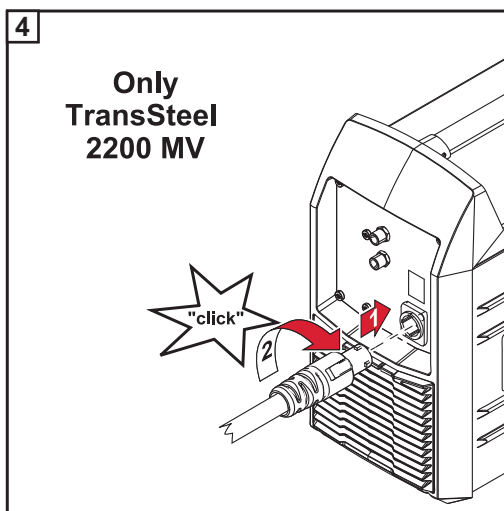
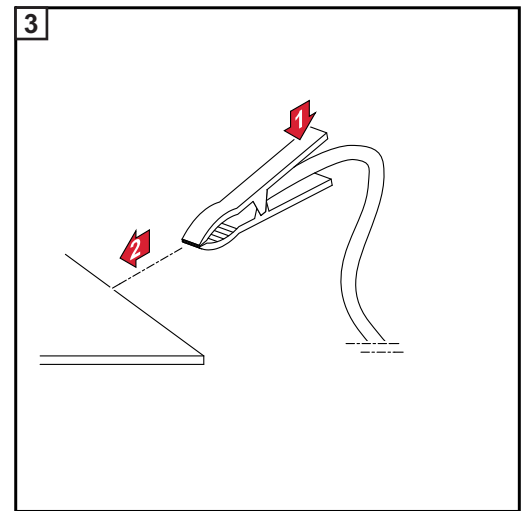
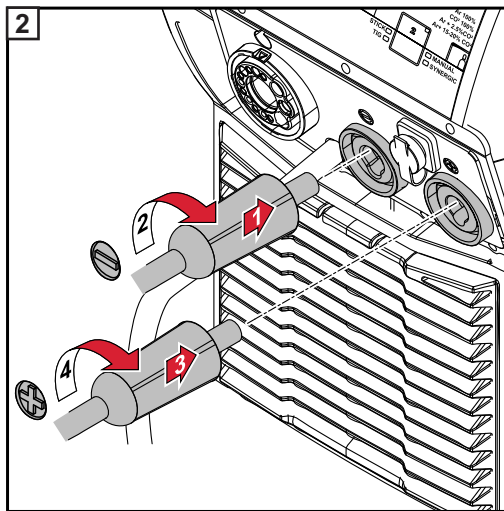

It is only necessary to connect the mains cable to the power source for multivoltage power sources.

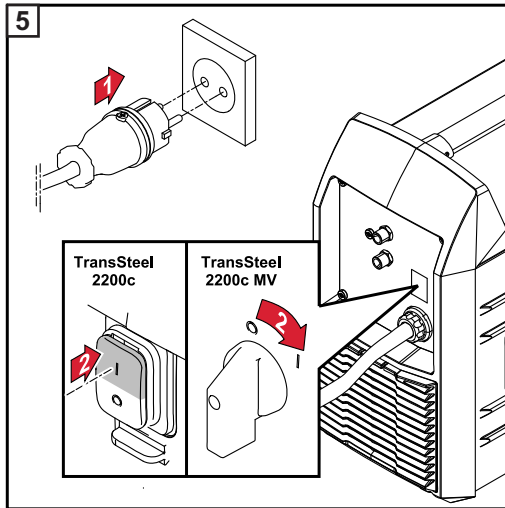

⚠ CAUTION!

Danger due to welding processes starting unintentionally.

Personal injury and damage to property may result.

- ▶ As soon as the power source is switched on, ensure that the rod electrode does not accidentally, or in an uncontrolled manner, touch any electrically conductive or grounded parts (e.g., the housing, etc.).

Manual metal arc welding

- 1 Press the "Process" button to select STICK



- 2 Set the desired welding current
 - Power source is ready for welding

Functions for Optimizing the Welding Process

Arc-Force Dynamic

Arc-force dynamic:

For influencing the short-circuiting dynamic at the instant of droplet transfer

- = hard, stable arc
- 0 = neutral arc
- + = soft, low-spatter arc

HotStart (Hti) Function

This function is activated at the factory.

Advantages

- Improved ignition properties, even when using electrodes with poor ignition properties
- Better fusion of the parent material during the start-up phase, meaning fewer cold-shut defects
- Slag inclusions largely avoided

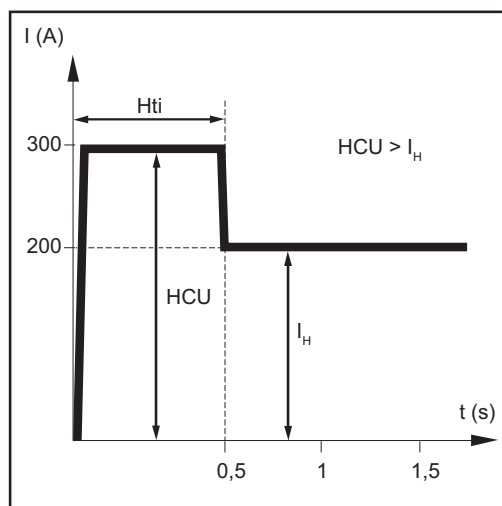

Legend

H_{ti} : Hot-current time,

0 - 2 s, factory setting 0.5 s

H_{CU} : HotStart current,

100 - 200%, factory setting 150%

I_H : Main current = set welding current

The H_{ti} and H_{CU} parameters can be set in the Setup menu.

Function

During the specified hot-current time (H_{ti}), the welding current is increased to a certain value. This value (H_{CU}) is higher than the selected welding current (I_H).

Anti-stick (Ast) Function

This function is activated at the factory.

As the arc becomes shorter, the welding voltage may also fall so that the rod electrode is more likely to stick to the workpiece. This may also cause the rod electrode to burn out.

Electrode burn-out is prevented by activating the anti-stick function. If the rod electrode begins to stick, the power source immediately switches the welding current off. The welding process can be resumed without problems once the rod electrode has been detached from the workpiece.

Deactivating the function:

- 1 Set the Ast (anti-stick) setup parameter to OFF

EasyJobs

Saving and Retrieving EasyJobs

General

- The "Save" buttons allow two EasyJobs to be saved
 - The adjustable parameters on the control panel are saved
 - Setup parameters are not saved at this time
-

Saving an Easy-Job

- 1 Press and hold one of the "Save" buttons to save the current settings on the control panel, e.g., Number 1



- The left indicator displays "Pro"
- After a short time, the left indicator switches to the original value

- 2 Release the "Save" button



Retrieving an EasyJob

- 1 To retrieve saved settings, press the corresponding "Save" button briefly, e.g., Number 1



- The control panel will show the saved settings
-

Deleting an Easy-Job

- 1 Press and hold the relevant "Save" button to delete the memory content of that "Save" button, e.g., Number 1



- The left indicator displays "Pro"
- After a short time, the left indicator switches to the original value

- 2 Keep the "Save" button held down



- The left indicator displays "CLr"
- After a while, both indicators display "---"

- 3 Release the "Save" button



Setup Menu

Setup Menu Level 1

Operation

Accessing the Setup menu is described with reference to the MIG/MAG standard synergic (SYNERGIC) welding process.

Access is the same for the other welding processes.

Accessing the Setup menu

- 1 Press the "Process" button to select SYNERGIC (to access the Setup menu for MIG/MAG standard manual welding, press the "Process" button and select the MANUAL welding process)



- 2 Press and hold the "Mode" button



- 3 Release the "Mode" and "Process" buttons

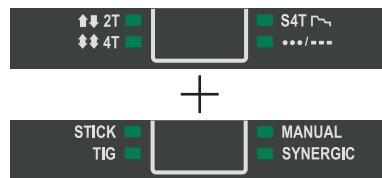

Changing parameters

- 1 Select the desired setup parameter using the left-hand adjusting dial



- 2 Change the setup parameter value using the right-hand adjusting dial



Exiting the Setup menu

- 1 Press and hold the "Mode" button



- 2 Press the "Process" button



- 3 Release the "Mode" and "Process" buttons

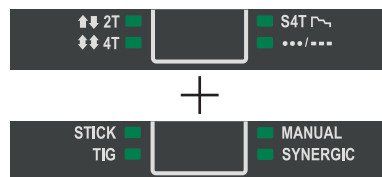

GPr	Gas pre-flow time Unit: seconds Setting range: 0 - 9.9 Factory setting: 0.1
GPo	Gas post-flow time Unit: seconds Setting range: 0 - 9.9 Factory setting: 0.5
Fdi	Feeder inching speed Unit: m/min (ipm) Setting range: 1 - 18.5 (39.37 - 728.35) Factory setting: 10 (393.7)
IGc	Ignition current Unit: Ampere Setting range: 100 - 390 Factory setting: 300
Ito	Length of wire that is fed before the safety cut-out trips Unit: mm (in.) Setting range: OFF, 5 - 100 (OFF, 0.2 - 3.94) Factory setting: OFF The ignition time-out function (Ito) is a safety feature. If the power source determines that no ignition has occurred after the preset wire length has been fed, wirefeeding is stopped.
SPt	Spot welding time Unit: seconds Setting range: OFF, 0.3 - 5 Factory setting: 1
SPb	Spot pause time Unit: seconds Setting range: OFF, 0.3 - 10 (in 0.1 s increments) Factory setting: OFF
Int	Interval Unit: - Setting range: 2T (2-step), 4T (4-step) Factory setting: 2T (2-step)
FAC	Reset power source to factory settings Press and hold one of the "Parameter selection" buttons for two seconds to restore the factory settings - when "PrG" appears on the digital display, the power source has been reset When the power source is reset, the majority of the applied settings are deleted. The following values remain: - Welding circuit resistance and welding circuit inductivity - Country-specific setting
2nd	Second level of the Setup menu (see "Setup Menu 2nd Level")

**Parameters for
MIG/MAG Stan-
dard Synergic
Welding**

GPr	Gas pre-flow time Unit: seconds Setting range: 0 - 9.9 Factory setting: 0.1
GPo	Gas post-flow time Unit: seconds Setting range: 0 - 9.9 Factory setting: 0.5
SL	Slope Unit: seconds Setting range: 0 - 9.9 Factory setting: 1
I-S	Starting current Unit: % of welding current Setting range: 0 - 200 Factory setting: 100
I-E	Final current Unit: % of welding current Setting range: 0 - 200 Factory setting: 50
t-S	Starting current duration Unit: seconds Setting range: 0 - 9.9 Factory setting: 0
t-E	Final current duration Unit: seconds Setting range: 0 - 9.9 Factory setting: 0
Fdi	Feeder inching speed Unit: m/min (ipm) Setting range: 1 - 18.5 (39.37 - 728.35) Factory setting: 10 (393.7)
Ito	Length of wire that is fed before the safety cut-out trips Unit: mm (in.) Setting range: OFF, 5 - 100 (OFF, 0.2 - 3.94) Factory setting: OFF
	<p>The "Ignition time-out" function (Ito) is a safety function. If the power source determines that no ignition has occurred after the preset wire length has been fed, wire-feeding is stopped.</p>
SPt	Spot welding time Unit: seconds Setting range: 0.3 - 5 Factory setting: 1
SPb	Spot pause time Unit: seconds Setting range: OFF, 0.3 - 10 (in 0.1 s increments)

Factory setting: OFF

Int Interval

Unit: -

Setting range: 2T (2-step), 4T (4-step)

Factory setting: 2T (2-step)

FAC Reset power source to factory settings

Press and hold one of the "Parameter selection" buttons for two seconds to restore the factory settings

- when "PrG" appears on the digital display, the power source has been reset.

When the power source is reset, the majority of the applied settings are deleted. The following values remain:

- Welding circuit resistance and welding circuit inductivity
 - Country-specific setting
-

2nd Second level of the Setup menu (see "Setup Menu 2nd Level")

**Parameters for
TIG Welding**

F-P	Pulse frequency Unit: Hertz Setting range: OFF; 1 - 990 (up to 10 Hz: in 0.1 Hz increments) (up to 100 Hz: in 1 Hz increments) (over 100 Hz: in 10 Hz increments) Factory setting: OFF
tUP	UpSlope Unit: seconds Setting range: 0.01 - 9.9 Factory setting: 0.5
tdo	DownSlope Unit: seconds Setting range: 0.01 - 9.9 Factory setting: 1
I-S	Starting current Unit: % of main current Setting range: 1 - 200 Factory setting: 35
I-2	Reduced current Unit: % of main current Setting range: 1 - 100 Factory setting: 50
I-E	Final current Unit: % of main current Setting range: 1 - 100 Factory setting: 30
GPo	Gas post-flow time Unit: seconds Setting range: 0 - 9.9 Factory setting: 9.9
tAC	Tacking Unit: seconds Setting range: OFF, 0.1 - 9.9 Factory setting: OFF
FAC	Reset power source to factory settings Press and hold one of the "Parameter selection" buttons for two seconds to restore the factory settings - when "PrG" appears on the digital display, the power source has been reset.

When the power source is reset, the majority of the applied settings are deleted. The following values remain:

- Welding circuit resistance and welding circuit inductivity
- Country-specific setting

2nd	Second level of the Setup menu (see "Setup Menu 2nd Level")
------------	--

**Parameters for
MMA Welding**

HCU HotStart current

Unit: %

Setting range: 100 - 200

Factory setting: 150

Hti Hot current time

Unit: seconds

Setting range: 0 - 2.0

Factory setting: 0.5

Ast Anti-stick function

Unit: -

Setting range: On, OFF

Factory setting: On

FAC Reset power source to factory settings

Press and hold one of the "Parameter selection" buttons for two seconds to restore the factory settings

- when "PrG" appears on the digital display, the power source has been reset.

When the power source is reset, the majority of the applied settings are deleted. The following values remain:

- Welding circuit resistance and welding circuit inductivity
 - Country-specific setting
-

2nd Second level of the Setup menu (see "Setup Menu 2nd Level")

Setup Menu 2nd Level

Operation

Accessing the Setup menu

- 1 Press the "Process" button to select SYNERGIC (to access the Setup menu for MIG/MAG standard manual welding, press the "Process" button and select the MANUAL welding process)



- 2 Press and hold the "Mode" button



- 3 Press the "Process" button



- 4 Release the "Mode" and "Process" buttons

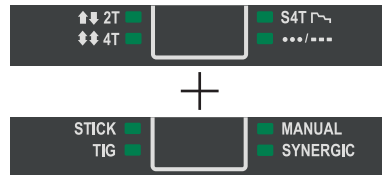

- 5 Select the "2nd" setup parameter using the left-hand adjusting dial



- 6 Press and hold the "Mode" button



- 7 Press the "Process" button



Changing parameters

- 1 Select the desired setup parameter using the left-hand adjusting dial



- 2 Change the setup parameter value using the right-hand adjusting dial



Exiting the Setup menu

- 1 Press and hold the "Mode" button



- 2 Press the "Process" button



- 3** Release the "Mode" and "Process" buttons
 - A parameter is displayed in the first level of the Setup menu

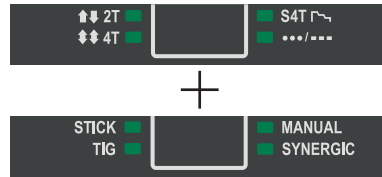

- 4** Press and hold the "Mode" button



- 5** Press the "Process" button



- 6** Release the "Mode" and "Process" buttons

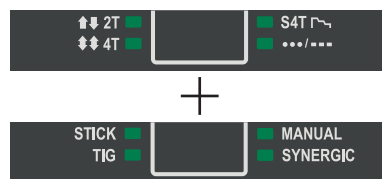

Parameters for MIG/MAG welding

SEt Country-specific setting (Standard/USA) Std/US

Unit: -

Setting range: Std, US (Standard/USA)

If Std is selected, the EURO welding programs are used as stated in the welding program table.

If US is selected, the US welding programs are used as stated in the welding program table.

Factory setting:

Standard version: Std (measurements: cm/mm)

USA version: US (measurements: inches)

FUS Mains fuse protection

The maximum possible welding power is limited by the rating of the mains fuse protection.

Unit: A

The available mains fuse ratings are determined by the SEt parameter setting:

SEt parameter set as Std: OFF / 10 / 13 / 16

SEt parameter set as US: OFF / 15 / 20 (only for 120 V mains voltage)

Factory setting: OFF

r Welding circuit resistance (in mOhm)

See section "Measuring welding circuit resistance r"

L **Welding circuit inductivity (in microhenrys)**
See section "Displaying welding circuit inductivity L"

EnE **Real Energy Input**

Unit: kJ
Setting range: ON / OFF
Factory setting: OFF

Since the full range of values (1 kJ - 99999 kJ) cannot be displayed on the three-digit display, the following display format has been selected:

Value in kJ: 1 to 999 / indicator on display: 1 to 999
Value in kJ: 1000 to 9999 / indicator on display: 1.00 to 9.99 (without unit digit, e.g., 5270 kJ -> 5.27)
Value in kJ: 10000 to 99999 / indicator on display: 10.0 to 99.9 (without unit digit or tens digit, e.g., 23580 kJ -> 23.6)

**Parameters for
MIG/MAG welding**

SEt **Country-specific setting (Standard/USA) Std/US**

Unit: -
Setting range: Std, US (Standard/USA)

If Std is selected, the EURO welding programs are used as stated in the welding program table.

If US is selected, the US welding programs are used as stated in the welding program table.

Factory setting:
Standard version: Std (measurements: cm/mm)
USA version: US (measurements: inches)

FUS **Mains fuse protection**

The maximum possible welding power is limited by the rating of the mains fuse.

Unit: A
The available mains fuse ratings are determined by the SEt parameter setting:
SEt parameter set as Std: OFF / 10 / 13 / 16
SEt parameter set as US: OFF / 15 / 20 (only for 120 V mains voltage)
Factory setting: OFF

r **Welding circuit resistance (in mOhm)**
See section "Measuring welding circuit resistance r"

L **Welding circuit inductivity (in microhenrys)**
See section "Displaying welding circuit inductivity L"

EnE Real Energy Input

Unit: kJ

Setting range: ON / OFF

Factory setting: OFF

Since the full range of values (1 kJ - 99999 kJ) cannot be displayed on the three-digit display, the following display format has been selected:

Value in kJ: 1 to 999 / indicator on display: 1 to 999

Value in kJ: 1000 to 9999 / indicator on display: 1.00 to 9.99 (without unit digit, e.g., 5270 kJ -> 5.27)

Value in kJ: 10000 to 99999 / indicator on display: 10.0 to 99.9 (without unit digit or tens digit, e.g., 23580 kJ -> 23.6)

ALC Arc length correction display

(For setting how the arc length correction parameter is displayed)

Setting range: ON / OFF

Factory setting: OFF

Set to ON if the welding voltage parameter is selected and set on the control panel

- The left-hand display shows the arc correction value for three seconds
 - The right-hand display shows the value for the welding voltage at the same time
-

**Parameters for
TIG Welding (Set-
up Menu 2nd
Level)**

C-C Cooling unit control

(only with TST 3500c MP and if cooling unit is connected)

Unit: -

Setting range: Aut, On, OFF

Factory setting: Aut

Aut: The cooling unit cuts out after a 2-minute welding off-time.

IMPORTANT! If the coolant temperature and flow monitoring options have been installed in the cooling unit, the cooling unit cuts out as soon as the return-flow temperature drops below 50 °C, but at the earliest after a 2-minute welding off-time.

On: The cooling unit is permanently ON

OFF: The cooling unit is always OFF

IMPORTANT! If the FAC welding parameter is used, the C-C parameter is not reset to the factory setting. If the MMA welding process is selected, the cooling unit is always switched off, even if the switch is in the "On" position.

C-t Cooling time

(only with TST 3500c MP and if cooling unit is connected)

Time from when flow monitoring is triggered until the "no | H2O" service code is output. For example, if there are air bubbles in the cooling system, the cooling unit will not cut out until the end of this preset time.

Unit: s

Setting range: 5 - 25

Factory setting: 10

IMPORTANT! Every time the power source is switched on, the cooling unit carries out a test run for 180 seconds.

SEt Country-specific setting (Standard/USA) ... Std/US

Unit: -

Setting range: Std, US (Standard/USA)

If Std is selected, the Euro welding programs are used as stated in the welding program table.

If US is selected, the US welding programs are used as stated in the welding program table.

Factory setting:

Standard version: Std (measurements in cm/mm)

USA version: US (measurements: inches)

FUS Mains fuse

The maximum possible welding power is limited by the rating of the mains fuse protection used.

Unit: A

The available mains fuse ratings are determined by the SEt parameter setting:

SEt parameter set as Std: OFF / 10 / 13 / 16
SEt parameter set as US: OFF / 15 / 20 (only for 120 V grid voltage)

Factory setting: OFF

**Parameters for
Manual Metal Arc
Welding (Setup
Menu 2nd Level)**

SEt **Country-specific setting (Standard/USA) ... Std/US**

Unit: -

Setting range: Std, US (Standard/USA)

If Std is selected, the Euro welding programs are used as stated in the welding program table.

If US is selected, the US welding programs are used as stated in the welding program table.

Factory setting:

Standard version: Std (measurements in cm/mm)

USA version: US (measurements: inches)

r **Welding circuit resistance (in mOhm)**

See "Measuring the Welding Circuit Resistance r"

L **Welding circuit inductivity (in microhenrys)**

See "Displaying the Welding Circuit Inductivity L"

FUS **Mains fuse**

The maximum possible welding power is limited by the rating of the mains fuse protection used.

Unit: A

The available mains fuse ratings are determined by the SEt parameter setting:

SEt parameter set as Std: OFF / 10 / 13 / 16

SEt parameter set as US: OFF / 15 / 20 (only for 120 V grid voltage)

Factory setting: OFF

Optimizing Weld Quality

Measuring the Welding Circuit Resistance r

General

Measuring the welding circuit resistance r makes it possible to have a constant welding result at all times, even with hosepacks of different lengths. The welding voltage at the arc is then always precisely regulated, regardless of the length and cross-sectional area of the hosepack. The use of arc length correction is no longer required.

The calculated welding circuit resistance is shown on the display.

r = welding circuit resistance in milliohm (mOhm)

If the welding circuit resistance r has been measured correctly, the set welding voltage will correspond exactly to the welding voltage at the arc. If you manually measure the voltage on the output jacks of the power source, this voltage will be higher than the welding voltage at the arc - that is, higher by the same amount as the voltage drop of the hosepack.

The welding circuit resistance r depends on the hosepack used:

- If the length or cross-sectional area of the hosepack has changed, measure the welding circuit resistance r again
- Measure the welding circuit resistance for every welding process separately with the appropriate welding power-leads

Measuring the Welding Circuit Resistance r

NOTE!

Risk of incorrect measurement of the welding circuit resistance.

This can have a negative effect on the welding results.

- Ensure that the workpiece has an optimum contact surface in the area of the earthing clamp (clean surface, no rust, etc.).

- 1 Establish a ground earth connection to the workpiece
- 2 Access the Setup menu 2nd level (2nd)
- 3 Select parameter "r"
- 4 Remove the gas nozzle from the welding torch
- 5 Screw on the contact tip

NOTE!

Risk of incorrect measurement of the welding circuit resistance.

This can have a negative effect on the welding results.

- Ensure that the workpiece has an optimum contact surface for the contact tip (clean surface, no rust, etc.).

- 6 Place the contact tip flush against the workpiece surface
- 7 Press the torch trigger briefly
 - The welding circuit resistance is calculated. "run" is shown on the display during the measurement

The measurement is finished when the welding circuit resistance is shown on the display in mOhm (for example 11.4).

- 8 Fit the gas nozzle back onto the welding torch

Displaying the Welding Circuit Inductivity L

General

The way that the hosepack is arranged has a very significant effect on the welding circuit inductivity and therefore affects the welding process. It is important to lay the hosepacks correctly in order to obtain the best possible welding result.

Displaying the Welding Circuit Inductivity L

The setup parameter "L" is used to display the most recently calculated welding circuit inductivity. The welding circuit inductivity is adjusted when the welding circuit resistance r is measured. Detailed information can be found in the "Measuring the Welding Circuit Resistance r " chapter.

- 1 Access the Setup menu 2nd level (2nd)
- 2 Select parameter "L"

The most recently calculated welding circuit inductivity L is shown on the right-hand digital display.

L ... Welding circuit inductivity (in microhenrys)

Laying the Hosepacks Correctly

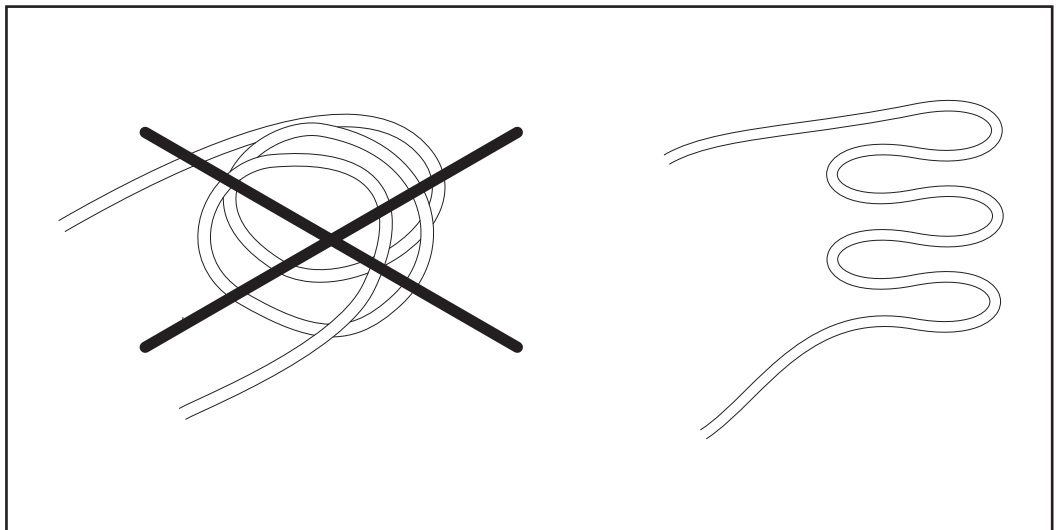

Troubleshooting and Maintenance

Displaying Service Parameters

Service parameters

Various service parameters can be retrieved by pressing the left and right-hand "Parameter selection" buttons at the same time.

Opening the display

- 1 Press and hold the "Parameter selection" button (left)

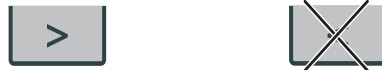

- 2 Press the "Parameter selection" button (right)



- 3 Release the "Parameter selection" buttons



- 4 Select the desired service parameter using the left-hand adjusting dial



Available parameters

Firmware version	Example: 1.00 4.21
Welding program configuration	Example: 2 491
Number of the currently selected welding program	Example: r 2 290
Indicates the actual arc time since first use Note: The arc time indicator is not suitable as a basis for calculating hiring fees, warranty services, etc.	Example: 654 32.1 = 65,432.1 hours = 65,432 hours 6 mins
Motor current for wire drive in amperes (The value changes as soon as the motor is running)	Example: iFd 0.0
2nd menu level for service engineers	2nd

Troubleshooting

Safety



WARNING!

Danger from incorrect operation and work that is not carried out properly.

Serious personal injury and damage to property may result.

- ▶ All the work and functions described in this document must only be carried out by trained and qualified personnel.
 - ▶ Read and understand this document.
 - ▶ Read and understand all the system component Operating Instructions, especially the safety rules.
-



WARNING!

Danger from electrical current.

Serious injuries or death may result.

- ▶ Turn the mains switch of the power source to - O - and disconnect the power source from the mains
 - ▶ Secure all devices and components involved so they cannot be switched back on.
 - ▶ After opening the device, use a suitable measuring instrument to check that electrically charged components (such as capacitors) have been discharged.
-



WARNING!

Electrical current hazard caused by an inadequate ground conductor connection.

Serious personal injury and damage to property may result.

- ▶ Always use the original housing screws in the quantity initially supplied.
-

Troubleshooting

Make a note of the serial number and configuration of the device, and provide the service team with a detailed error description if:

- Errors occur that are not covered in this document
 - The troubleshooting measures provided in this document are unsuccessful
-

Power source not working

Power source switched on, displays do not illuminate

Cause: Grid lead damaged or broken, grid plug not inserted

Remedy: Check grid lead, if necessary insert grid plug

Cause: Grid socket or grid plug faulty

Remedy: Replace faulty parts

Cause: Grid fuse

Remedy: Replace grid fuse

Nothing happens when the torch trigger is pressed

Power source mains switch is ON and indicators are lit up

Cause: Welding torch or welding torch control line faulty

Remedy: Replace welding torch

No welding current

Mains switch is on, one of the overtemperature service codes "to" is displayed. Detailed information on the service codes "to0" to "to6" can be found in the section "Displayed service codes".

Cause: Overloading
Remedy: Check duty cycle

Cause: Thermostatic automatic circuit breaker has been tripped
Remedy: Wait until the power source automatically comes back on after the end of the cooling phase

Cause: Limited supply of cooling air
Remedy: Clean air filter, ensure accessibility to cooling air ducts

Cause: Fan in the power source is faulty
Remedy: Inform service team

No welding current

Power source switched on, displays illuminate

Cause: Incorrect ground connection
Remedy: Check ground connection for polarity

Cause: Power cable in welding torch damaged or broken.
Remedy: Replace welding torch

No shielding gas

All other functions are OK

Cause: Gas hose is not connected to the correct connection socket for the current welding process
Remedy: Connect the gas hose to the correct connection socket for the current welding process

Cause: Gas cylinder empty
Remedy: Change gas cylinder

Cause: Gas pressure regulator faulty
Remedy: Replace gas pressure regulator

Cause: Gas hose is not fitted or is damaged
Remedy: Fit or change gas hose

Cause: Welding torch faulty
Remedy: Change welding torch

Cause: Gas solenoid valve faulty
Remedy: Inform service team

Irregular wire speed

Cause: Braking force has been set too high

Remedy: Loosen the brake

Cause: Contact tip hole too narrow

Remedy: Use suitable contact tip

Cause: Faulty inner liner in welding torch

Remedy: Check the inner liner for kinks, dirt, etc. and replace if necessary

Cause: Feed rollers not suitable for wire electrode used

Remedy: Use suitable feed rollers

Cause: Incorrect contact pressure of feed rollers

Remedy: Optimize contact pressure

Wirefeed problems

Cause: Incorrect arrangement of welding torch hosepack

Remedy: Arrange the welding torch hosepack in as straight a line as possible, avoiding bends

Welding torch gets very hot

Cause: Welding torch is inadequately sized

Remedy: Observe duty cycle and load limits

Poor-quality weld properties

Cause: Incorrect welding parameters

Remedy: Check settings

Cause: Poor ground earth connection

Remedy: Establish good contact with workpiece

Cause: Too little or no shielding gas

Remedy: Check gas pressure regulator, gas hose, gas solenoid valve, welding torch gas connection, etc.

Cause: Welding torch leaks

Remedy: Change welding torch

Cause: Incorrect or heavily worn contact tip

Remedy: Change contact tip

Cause: Incorrect wire alloy or incorrect wire diameter

Remedy: Check wire electrode in use

Cause: Incorrect wire alloy or incorrect wire diameter

Remedy: Check weldability of the base material

Cause: Shielding gas not suitable for wire alloy

Remedy: Use correct shielding gas

Displayed Service Codes

If an error message that is not described here appears on the displays, proceed as follows to resolve the problem:

- 1 Turn the power source mains switch to the "O" position
- 2 Wait 10 seconds
- 3 Turn the mains switch to the "I" position

If the error occurs again despite several attempts to eliminate it, or if the troubleshooting measures listed here are unsuccessful:

- 1 Make a note of the error message displayed
- 2 Note down the configuration of the power source
- 3 Contact our After-Sales Service team with a detailed description of the error

ELn | 13

Cause: Impermissible change of welding process during welding

Remedy: During welding do not make any impermissible change to the welding process, reset error message by pressing any button

Err | IP

Cause: The power source control has detected a primary overvoltage

Remedy: Check the grid voltage, if the service code does not go away, switch off the power source, wait 10 seconds before switching it back on, if the error still persists, contact the After-Sales Service team

Err | 51

Cause: Mains undervoltage: Mains voltage has fallen below the tolerance range

Remedy: Check the mains voltage. If the service code remains, contact After-Sales Service

Err | 52

Cause: Mains overvoltage: Mains voltage has risen above the tolerance range

Remedy: Check the mains voltage. If the service code remains, contact After-Sales Service

EFd | 14, EFd | 81, EFd | 83

Cause: Fault in the wirefeed system - overcurrent in the wirefeeder motor (2-roller drive)

Remedy: Arrange the hosepack in as straight a line as possible; check that there are no kinks or dirt in the inner liner; check the contact pressure on the 2-roller drive; check that there is no entangled wire in the 2-roller drive

Cause: Wirefeeder motor is sticking or defective

Remedy: Check the wirefeeder motor or contact After-Sales Service

to0 | xxx

Note: xxx stands for a temperature value

Cause: Overtemperature on the PC board LSTMAG20 (secondary circuit)

Remedy: Allow power source to cool down, check air filter and clean if necessary, check that fan is on

to2 | xxx

Note: xxx stands for a temperature value

Cause: Overtemperature in the secondary circuit of the power source

Remedy: Allow power source to cool down, check air filter and clean if necessary, check that fan is on

to3 | xxx

Note: xxx stands for a temperature value

Cause: Overtemperature on the PC board LSTMAG20 (wirefeeder)

Remedy: Allow power source to cool down, check air filter and clean if necessary, check that fan is on

to6 | xxx

Note: xxx stands for a temperature value

Cause: Overtemperature on the PC board LSTMAG20 (voltage doubler)

Remedy: Allow power source to cool down, check air filter and clean if necessary, check that fan is on

to7 | xxx

Note: xxx stands for a temperature value

Cause: Overtemperature in the power source

Remedy: Allow power source to cool down, check air filter and clean if necessary, check that fan is on

to8 | xxx

Note: xxx stands for a temperature value

Cause: Overtemperature on the power module

Remedy: Allow power source to cool down, check that fan is on

to9 | xxx

Note: xxx stands for a temperature value

Cause: Overtemperature on the PFC module

Remedy: Allow power source to cool down, check that fan is on

toA | xxx

Note: xxx stands for a temperature value

Cause: Overtemperature on the PC board LSTMAG20 (PFC)

Remedy: Allow power source to cool down, check that fan is on

toF | xxx

Cause: The power source's safety cut-out reacted in order to prevent tripping of the mains fuse.

Remedy: After a pause in welding of around 90 s, the message disappears and the power source is operational again.

tu0 | xxx

Note: xxx stands for a temperature value

Cause: Undertemperature on the PC board (secondary circuit)

Remedy: Place power source in a heated room and allow it to warm up

tu2 | xxx

Note: xxx stands for a temperature value

Cause: Undertemperature in the power source secondary circuit

Remedy: Place power source in a heated room and allow it to warm up

tu3 | xxx

Note: xxx stands for a temperature value

Cause: Undertemperature on the PC board LSTMAG20 (wirefeeder)

Remedy: Place power source in a heated room and allow it to warm up

tu6 | xxx

Note: xxx stands for a temperature value

Cause: Undertemperature on the PC board LSTMAG20 (voltage doubler)

Remedy: Place power source in a heated room and allow it to warm up

tu7 | xxx

Note: xxx stands for a temperature value

Cause: Undertemperature in power source

Remedy: Place power source in a heated room and allow it to warm up

tu8 | xxx

Note: xxx stands for a temperature value

Cause: Undertemperature on the power module

Remedy: Place power source in a heated room and allow it to warm up

tu9 | xxx

Note: xxx stands for a temperature value

Cause: Undertemperature on the PFC module

Remedy: Place power source in a heated room and allow it to warm up

tuA | xxx

Note: xxx stands for a temperature value

Cause: Undertemperature on the PC board LSTMAG20 (PFC)

Remedy: Place power source in a heated room and allow it to warm up

no | Prg

Cause: No saved program selected

Remedy: Select saved program

no | IGn

Cause: "Ignition time-out" function is active; current did not start flowing before the length of wire specified in the Setup menu had been fed. The power source safety cut-out has tripped

Remedy: Shorten the wire stick-out; press the torch trigger again; clean the surface of the workpiece; if necessary, increase the setting in "Setup menu: Level 2" for the length of wire that is fed before the safety cut-out is triggered

no | ARC

Cause: Arc break during TIG welding

Remedy: Press the torch trigger repeatedly, clean the surface of the workpiece

EPG | 17

Cause: The selected welding program is invalid

Remedy: Select a valid welding program

EPG | 35

Cause: Measurement of the welding circuit resistance "r" failed

Remedy: Check grounding cable, current cable or hosepack and replace if necessary, re-measure the welding circuit resistance "r"

Service, maintenance and disposal

General

Under normal operating conditions, the welding system requires only a minimum of care and maintenance. However, several points must be observed in order for the welding system to remain operational for years to come.

Safety



WARNING!

Danger from incorrect operation and work that is not carried out properly.

Serious personal injury and damage to property may result.

- ▶ All the work and functions described in this document must only be carried out by trained and qualified personnel.
- ▶ Read and understand this document.
- ▶ Read and understand all the system component Operating Instructions, especially the safety rules.



WARNING!

Danger from electrical current.

Serious injuries or death may result.

- ▶ Turn the mains switch of the power source to - O - and disconnect the power source from the mains
- ▶ Secure all devices and components involved so they cannot be switched back on.
- ▶ After opening the device, use a suitable measuring instrument to check that electrically charged components (such as capacitors) have been discharged.



WARNING!

Electrical current hazard caused by an inadequate ground conductor connection.

Serious personal injury and damage to property may result.

- ▶ Always use the original housing screws in the quantity initially supplied.

At every start-up

- Ensure that the mains plug and mains cable as well as the welding torch / electrode holder are undamaged. Replace any damaged components
- Ensure a proper ground earth connection to the component
- Ensure there is an all-round clearance of 0.5 m (1 ft. 8 in.) around the device so that cooling air can circulate unimpeded. Air intake and exhaust openings must not be blocked or even partially covered.

As required, at least every two months

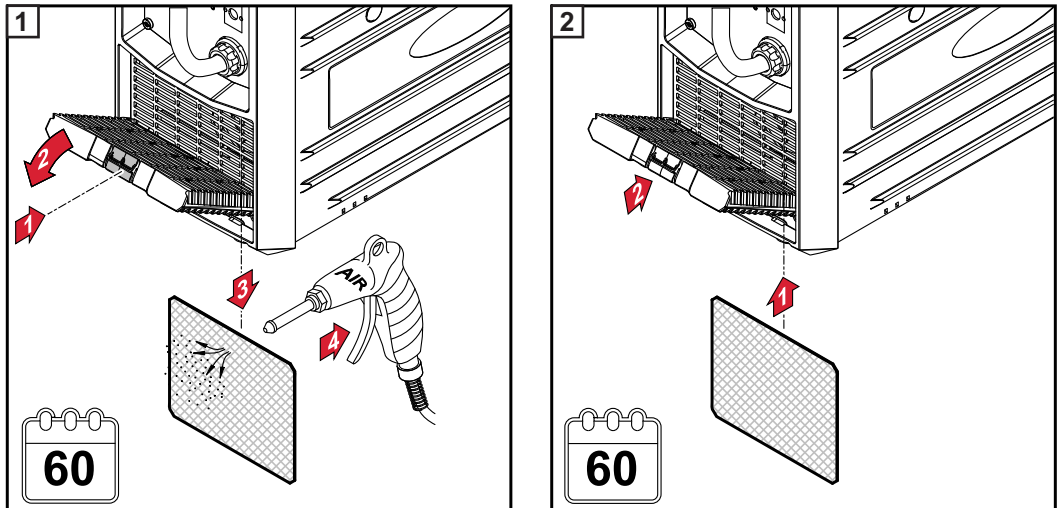

⚠ CAUTION!

Danger from wet air filter.

Damage to property may result

- ▶ Ensure that the air filter is dry when it is fitted.

Every 6 Months

⚠ CAUTION!

Danger due to the effect of compressed air.

This can result in damage to property.

- ▶ Do not bring the air nozzle too close to electronic parts.

- 1 Dismantle device side panels and blow the inside of the device clean with dry, reduced compressed air
- 2 Also clean the cooling air ducts if there is a large accumulation of dust

Disposal

Materials should be disposed of according to valid local and national regulations.

Removing Stiff Drive Rollers

Removing a stiff drive roller

If a drive roller is difficult to remove by hand, the knurled screw on the D100 brake can be used to remove it.

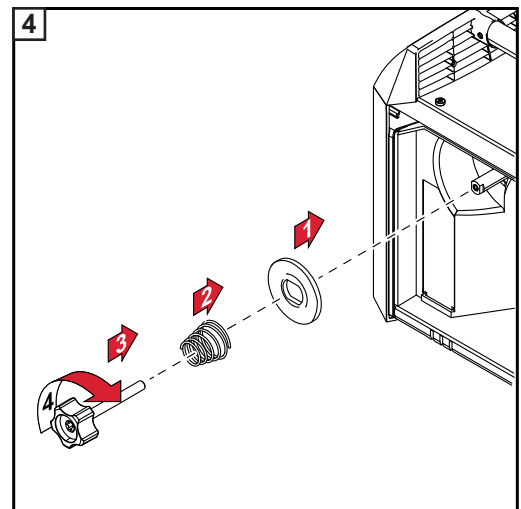
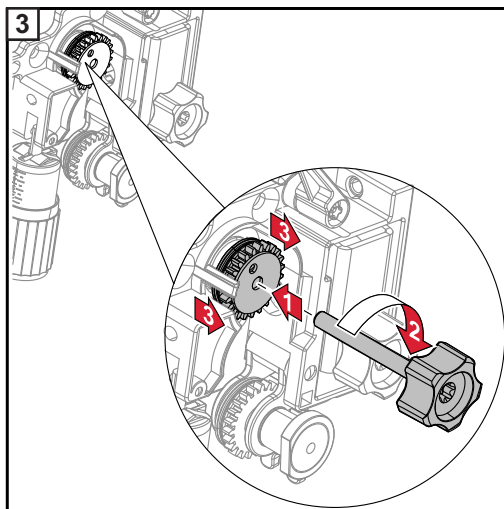
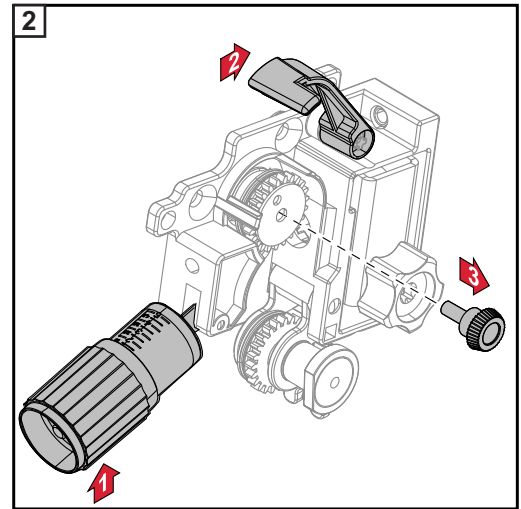
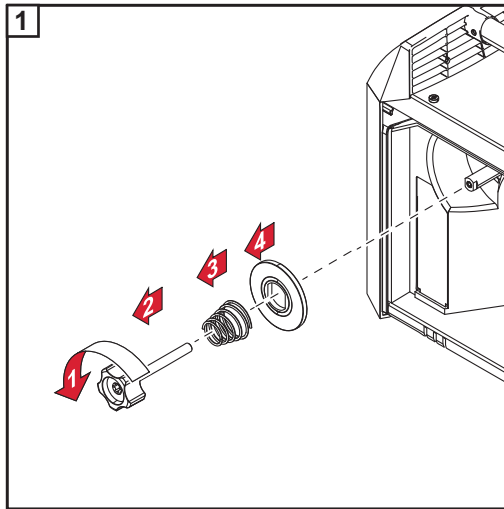

Technical Data

Special voltage For devices designed for special voltages, the technical data on the rating plate applies.

Explanation of the Term Duty Cycle The duty cycle (D.C.) is the period of a ten minute cycle in which the device may be operated at the stated power without overheating.

NOTE!

The D.

C. values cited on the rating plate relate to an ambient temperature of 40 °C. If the ambient temperature is higher, the D.C. or power must be lowered accordingly.

Example: Welding with 150 A at 60% D.C.

- Welding phase = 60% of 10 mins = 6 mins
- Cool-down phase = rest time = 4 mins
- Following the cool-down phase, the cycle begins again.

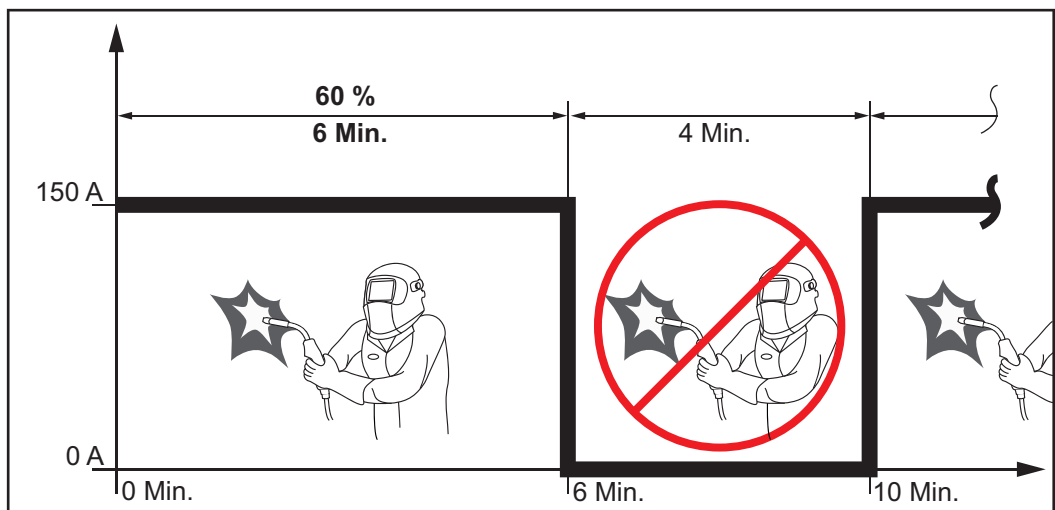

To use the device without interruptions:

- 1 Search for a 100% D.C. value in the technical data, which corresponds to the existing ambient temperature.
- 2 Reduce the power or amperage value correspondingly so that the device can operate without a cool-down phase.

Technical Data

TSt 2200

Mains voltage (U_1)	1 x	230 V		
Max. effective primary current (I_{1eff})		16 A		
Max. primary current (I_{1max})		26 A		
Mains fuse		16 A time-delay fuse		
Max. apparent power (S_{1max})		5.98 kVA		
Mains voltage tolerance		-20 / +15 %		
Grid frequency		50/60 Hz		
Cos phi (1)		0.99		
Max. permitted mains impedance Z_{max} on PCC ¹⁾		250.02 mOhm		
Recommended residual-current circuit breaker		Type B		
Welding current range (I_2)				
MIG/MAG		10 – 210 A		
Rod electrode		10 – 180 A		
TIG		10 – 230 A		
Welding current at	10 min/40 °C (104 °F)	30 %	60 %	100 %
MIG/MAG	U_1 230 V	210 A	170 A	150 A
Welding current at	10 min/40 °C (104 °F)	35 %	60 %	100 %
Rod electrode	U_1 230 V	180 A	150 A	130 A
Welding current at	10 min/40 °C (104 °F)	35 %	60 %	100 %
TIG	U_1 230 V	230 A	200 A	170 A
Output voltage range according to standard characteristic (U_2)				
MIG/MAG		14.5 – 24.5 V		
Rod electrode		20.4 – 27.2 V		
TIG		10.4 – 19.2 V		
Open circuit voltage (U_0 peak / U_0 r.m.s)		90 V		
Degree of protection		IP 23		
Type of cooling		AF		
Overvoltage category		III		
Pollution level according to IEC60664		3		
Safety symbols		S, CE		
Dimensions l x w x h		560 x 215 x 370 mm 22.05 x 8.46 x 14.57 in.		
Weight		15 kg 33.07 lb.		
Max. shielding gas pressure		5 bar 72.52 psi		

Wire speed	1.5 - 18 m/min 59.06 - 708.66 ipm
Wire drive	2-roller drive
Wire diameter	0.6 - 1.2 mm 0.025 - 0.047 in.
Wirespool diameter	max. 200 mm max. 7.87 in.
Wirespool weight	max. 6.8 kg max. 14.99 lb
Max. noise emission (LWA)	65.5 dB

1) Interface to a 230 V, 50 Hz public grid

TSt 2200 MV

Mains voltage (U_1)	1 x 120 V
Max. effective primary current ($I_{1\text{eff}}$)	15 A
Max. primary current ($I_{1\text{max}}$)	20 A
Mains fuse	15 A time-delay fuse
Max. apparent power ($S_{1\text{max}}$)	2.40 kVA

Mains voltage (U_1)	1 x 120 V
Max. effective primary current ($I_{1\text{eff}}$)	20 A
Max. primary current ($I_{1\text{max}}$)	29 A
Mains fuse	20 A time-delay fuse
Max. apparent power ($S_{1\text{max}}$)	3.48 kVA

Mains voltage (U_1)	1 x 230 V
Max. effective primary current ($I_{1\text{eff}}$)	16 A
Max. primary current ($I_{1\text{max}}$)	26 A
Mains fuse	16 A time-delay fuse
Max. apparent power ($S_{1\text{max}}$)	5.98 kVA

Mains voltage (U_1)	1 x 240 V
Max. effective primary current ($I_{1\text{eff}}$)	15 A
Max. primary current ($I_{1\text{max}}$)	26 A
Mains fuse ²⁾	20 A time-delay fuse ³⁾
Max. apparent power ($S_{1\text{max}}$)	6.24 kVA

Mains voltage tolerance	-20 / +15 %
Grid frequency	50/60 Hz
Cos phi	0.99
Max. permitted mains impedance Z_{max} on PCC ¹⁾	250.02 mOhm
Recommended residual-current circuit breaker	Type B

Welding current range (I_2)	
MIG/MAG	10 – 210 A
Rod electrode	10 – 180 A

TIG			10 – 230 A		
Welding current at	10 min/40 °C (104 °F)	30 %	60 %	100 %	
MIG/MAG	U ₁ 120 V (15 A)	105 A	95 A	80 A	
	U ₁ 120 V (20 A)	135 A	120 A	105 A	
	U ₁ 230 V	210 A	170 A	150 A	
Welding current at	10 min/40 °C (104 °F)	35 %	60 %	100 %	
Rod electrode	U ₁ 120 V (15 A)	90 A	80 A	70 A	
	U ₁ 120 V (20 A)	110 A	100 A	90 A	
	U ₁ 230 V	180 A	150 A	130 A	
Welding current at	10 min/40 °C (104 °F)	35 %	60 %	100 %	
TIG	U ₁ 120 V (15 A)	135 A	120 A	105 A	
	U ₁ 120 V (20 A)	160 A	150 A	130 A	
	U ₁ 230 V	230 A	200 A	170 A	
Output voltage range according to standard characteristic (U ₂)					
MIG/MAG		14.5 – 24.5 V			
Rod electrode		20.4 – 27.2 V			
TIG		10.4 – 19.2 V			
Open circuit voltage (U ₀ peak / U ₀ r.m.s)		90 V			
Degree of protection					
		IP 23			
Type of cooling					
		AF			
Overvoltage category					
		III			
Pollution level according to IEC60664					
		3			
Safety symbols					
		S, CE, CSA			
Dimensions l x w x h					
		560 x 215 x 370 mm 22.05 x 8.46 x 14.57 in.			
Weight					
		15.2 kg 33.51 lb.			
Max. shielding gas pressure					
		5 bar 72.52 psi			
Wire speed					
		1.5 - 18 m/min 59.06 - 708.66 ipm			
Wire drive					
		2-roller drive			
Wire diameter					
		0.6 - 1.2 mm 0.025 - 0.047 in.			
Wirespool diameter					
		max. 200 mm max. 7.87 in.			
Wirespool weight					
		max. 6.8 kg max. 14.99 lb			
Max. noise emission (LWA)					
		65.5 dB			

- 1) Interface to a 230 V, 50 Hz public grid
- 2) Only applies to USA:
If an automatic circuit breaker is used instead of a fuse, the current/time characteristic of the automatic circuit breaker must match that of the mains fuse specified above.
It is permitted for the tripping current of the automatic circuit breaker to be higher than the tripping current of the mains fuse specified above.
- 3) Only applies to USA:
Time-delay fuse conforming to UL Class RK5 (see UL 248).

FRONIUS INTERNATIONAL GMBH

Vorchdorfer Straße 40, A-4643 Pettenbach, Austria

E-Mail: sales@fronius.com

www.fronius.com

Under www.fronius.com/contact you will find the addresses
of all Fronius Sales & Service Partners and locations