

# RAVAS-110

Pallet truck scale with basic scale functions

## BENEFITS:

- The RAVAS work horse
- All basic scale functions
- Competitive pricing
- Low power consumption
- For checking incoming goods and shipping weights

Top quality

For industrial use

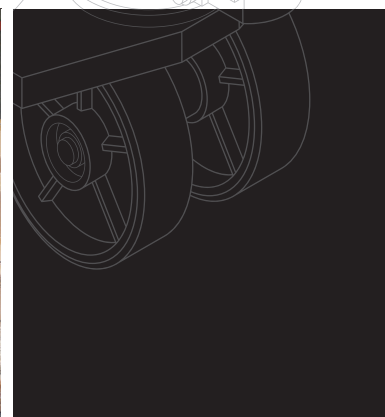

**RAVAS** ECONOMY LINE

# RAVAS



## FUNCTIONS

- Automatic and manual zero correction
- Gross/net weighing
- Totalling with sequence number
- Error messages in display
- Auto shut off after 3 minutes of non-use
- Low battery warning in display

## STANDARD SPECIFICATIONS

- Weighing capacity 5,000 lb
- Graduation 2 lb
- Max. inaccuracy 0.1% of the load lifted
- Display LCD, digit height 0.7 inch
- Keypad 3 function keys, on/off button
- Protection class NEMA 4 / IP65
- Steering wheels rubber
- Loading wheels polyurethane, single
- Finishing / Color epoxy coated / red, RAL3000
- Own weight 270 lb
- Power supply 4 x 1.5V AA-batteries in battery drawer
- Battery life one year, when used 5 times a day
- Pump quick lift

## DIMENSIONS IN INCHES

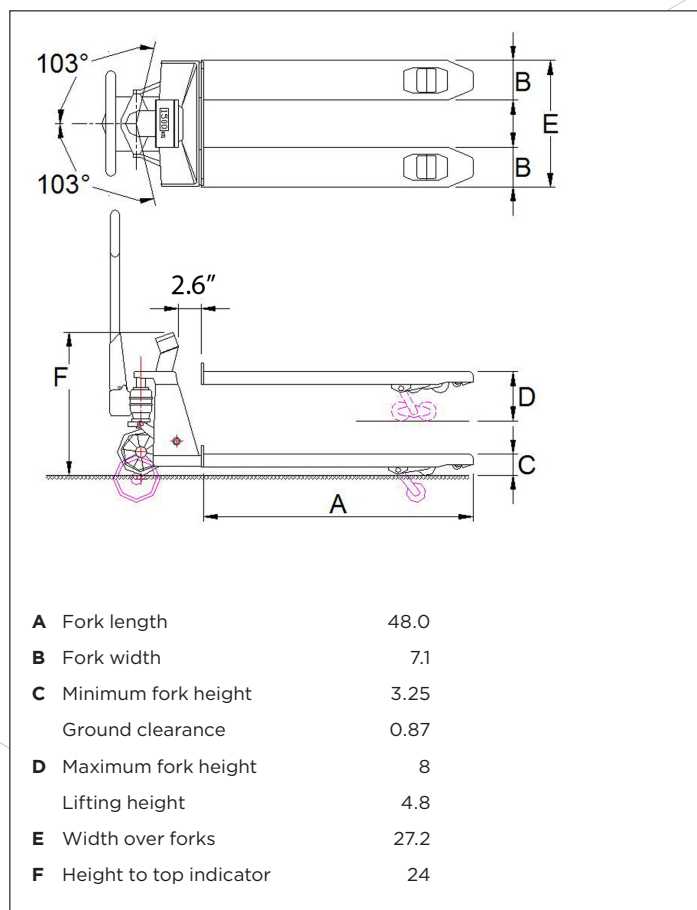

## OPTIONS\*

- Integrated thermal printer
- Stainless steel chassis with polymer housing
- Width over forks 22 inch
- Foot brake
- Polyurethan steering wheels
- Nylon steering wheels
- Polyurethan tandem loading wheels

\* The use of options may change related specifications