

MSI-4260 IS

Port-A-Weigh Intrinsically Safe Crane Scale

Technical Manual



An ISO 9001 registered company
© Rice Lake Weighing Systems. All rights reserved.

Rice Lake Weighing Systems® is a registered trademark of
Rice Lake Weighing Systems.

All other brand or product names within this publication are trademarks or
registered trademarks of their respective companies.

All information contained within this publication is, to the best of our knowledge, complete and accurate at
the time of publication. Rice Lake Weighing Systems reserves the right to make changes to the technology,
features, specifications and design of the equipment without notice.

The most current version of this publication, software, firmware and all other product
updates can be found on our website:

www.ricelake.com

1.0	Introduction	1
1.1	Features	1
1.2	Safety	2
1.3	Display	3
1.3.1	Keypad Functions	3
1.3.2	Annunciators and LEDs	4
2.0	Installation	5
2.1	Unpacking	5
2.2	Battery Pack	5
2.2.1	Battery Life	5
2.2.2	Battery Charger	6
2.2.3	Battery Replacement	7
2.3	Servicing	7
3.0	Operation	8
3.1	Navigation of Menus	8
3.2	Power	8
3.3	Zero	8
3.4	Tare	9
4.0	Setup	10
4.1	Setup Menu	10
4.1.1	Set Function Key	11
4.1.2	Test	11
4.1.3	Total	12
4.1.4	View Total	12
4.1.5	Net / Gross	12
4.1.6	Learn	12
4.1.7	Peak Hold	12
4.1.8	Units	12
4.1.9	Print	12
4.2	Auto-Off	13
4.3	Sleep	13
4.4	Display Brightness	14
4.5	Setpoints	14
4.6	Total	16
4.7	Filter Setup	17
4.8	Units	17
4.9	Battery Life	17
5.0	Calibration	18
5.1	Calibration Switch Access	18
5.2	Standard Calibration	18
5.3	Initial Calibration	19
5.4	Guidelines for Capacity and Resolution	20
5.5	C-Cal Calibration	21
5.6	Calibration Setup Menu	21
5.6.1	Standard Menu	22
5.7	Auto Zero Maintenance	22



Technical training seminars are available through Rice Lake Weighing Systems. Course descriptions and dates can be viewed at www.ricelake.com/training or obtained by calling 715-234-9171 and asking for the training department.

Contents

6.0	Troubleshooting / Maintenance.....	23
6.1	Troubleshooting	23
6.2	Service Counters	24
	6.2.1 Access the Service Counters:	24
6.3	MSI-4260 IS Port-A-Weigh Dimensions	25
6.4	Specifications	26



Rice Lake continually offers web-based video training on a growing selection of product-related topics at no cost. Visit www.ricelake.com/webinars

1.0 Introduction

The *MSI-4260 IS Port-A-Weigh* has an established reputation as the industry standard in medium to heavy-capacity overhead weighing and duty-cycle needs. With a proven mechanical design and advanced electronics, the *MSI-4260 IS* is versatile, reliable, accurate and user friendly.

The *MSI-4260 IS* is designed to meet or exceed requirements of applicable ASME, ANSI, OSHA safety standards. Multiple options and accessories are available to further enhance the performance and application versatility of the *MSI-4260 IS*.

This manual provides information on installation, calibration, configuration and operation of the *MSI-4260 IS*. The installer should be familiar with the National Electric Code and RP 12.6 (*Recommended Practice*) requirements for installation of equipment in hazardous areas (NEC Article 504, *Intrinsically Safe Systems*) published through the Instrument Society of America.

Refer to the Conditions of Use in Hazardous Locations document, PN 184530, for intrinsic safety certification and classification, specific conditions of use and system limitations and restrictions for the *MSI-4260 IS*.



Manuals are available for viewing and/or downloading from the Rice Lake Weighing Systems website at www.ricelake.com/manuals

Warranty information can be found on the website at www.ricelake.com/warranties

1.1 Features

- The *MSI-4260 IS* is FM Approved
- Designed to meet or exceed applicable U.S. and international safety standards
- Automatic power off conserves battery life by sensing no activity after a set number minutes and turns off the power
- Automatic sleep mode preserves the battery life by dimming the LED display after a set number of minutes of no activity
- Rugged construction throughout; The buttons are sealed and rated for over 1 million operations
- Precise high resolution (2,500 division standard and up to 10,000 possible) 24 bit A/D conversion provides world class features and accuracy
- Five large, 1.2" (30.5 mm) LED digits for clear weight readings from a distance; The display is always tilted down for ease of viewing from below
- Easy to maintain: Full digital calibration assures reliable, repeatable measurements; Can be calibrated without test weights using MSI C-Cal technology
- Selectable for kg/lb unless prohibited by Legal for Trade regulations
- Provides automatic or manual weight totalization for loading operations
- Easily customized for special applications with oversized attachments and interface hardware
- Hi speed Peak mode for wire and rope stress analysis
- Eight setpoints can be set for any in-range weight for operator alerts or process control
- ScaleCore technology provides quick and easy software updates and calibration/setup backup
- Two service counters ensure load train safety by warning the user to perform a load train safety check when the lift count gets high or the scale has been overloaded repeatedly

1.2 Safety

Safety Signal Definitions:



Indicates an imminently hazardous situation that, if not avoided, will result in death or serious injury. Includes hazards that are exposed when guards are removed.



Indicates a potentially hazardous situation that, if not avoided could result in serious injury or death. Includes hazards that are exposed when guards are removed.



Indicates a potentially hazardous situation that, if not avoided, could result in minor or moderate injury.



Indicates information about procedures that, if not observed, could result in damage to equipment or corruption to and loss of data.

General Safety



Do not operate or work on this equipment unless this manual has been read and all instructions are understood. Failure to follow the instructions or heed the warnings could result in injury or death. Contact any Rice Lake Weighing Systems dealer for replacement manuals.



Failure to heed could result in serious injury or death.

Do not operate or work on this equipment before reading and understanding the intrinsic safety information in the Conditions of Use in Hazardous Locations document, PN 184530.

Do not allow minors (children) or inexperienced persons to operate this unit.

Do not stand near the load being lifted as it is a potential falling hazard. Keep a safe distance.

Do not use for purposes other than weight taking or dynamic load monitoring.

Do not use any load bearing component that is worn beyond five percent of the original dimension.

Do not use the scale if any of the components of the load train are cracked, deformed or show signs of fatigue.

Do not exceed the rated load limit of the scale, rigging elements or the lifting structure.

Do not allow multi-point contact with the hook, shackle or lifting eye of the scale.

Do not allow high torque on the scale unless it is specifically designed for high torque.

Do not make alterations or modifications to the scale or associated load bearing devices.

Do not use improperly rated or sized shackles. Use only Rice Lake Weighing Systems recommended shackles.

Do not remove or obscure warning labels.

For guidelines on the safe rigging and loading of overhead scales and dynamometers, read the MSI Crane Scale Safety and Periodic Maintenance Manual (available at www.ricelake.com).

Keep hands, feet and loose clothing away from moving parts.

There are no user serviceable parts within the MSI-4260 IS. Any repairs must be performed by qualified service personnel only.

Removing the Warranty and Liability label compromises the FM Intrinsic Safety certification.

The MSI-4260 IS Port-A-Weigh scale has a safe mechanical overload of 200 percent and an ultimate overload of 500 percent. Overloads greater than 50 percent could result in structural failure and dropped loads. Dropped loads could cause serious personal injury or death.

1.3 Display

The buttons and display of the *MSI-4260 IS* front panel are described below.

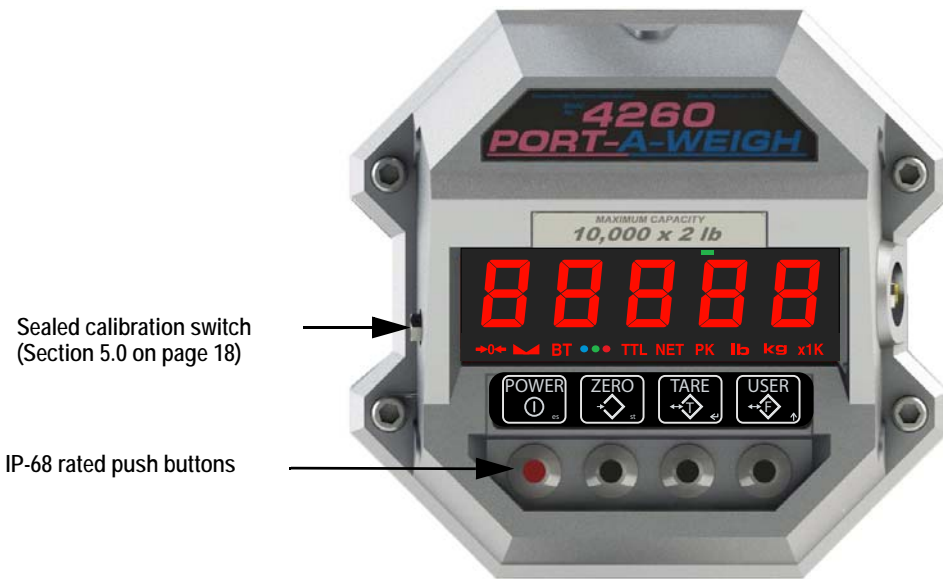

Figure 1-1. *MSI-4260 IS* Front Panel

1.3.1 Keypad Functions





Key	Description
	Turns the <i>MSI-4260 IS</i> On and Off.
	Used to zero out residual weight on the scale.
	Removes the weight of containers, trucks or carriers and places the scale in the net weight mode.
	Programmable to user selectable functions. See Section 3.0 on page 8. This key is defaulted to the Test function.

Table 1-1. *Key Functions and Annunciators*

1.3.2 Annunciators and LEDs



Annunciator	Description
→0←	Center of Zero — indicates the scale is zeroed and the weight is within 1/4d of zero.
▲▼	Stable — indicates the weight has settled within the motion window (usually $\pm 1d$). When this symbol is off, the scale will not zero, tare or totalize.
BT	Low Battery — displays when 10% of battery life remains. LED blinks indicating automatic shutdown will occur.
● ● ●	Setpoints — user programmable set points for early overload warnings. Blue LED = Setpoint 1, Green LED = Setpoint 2, Red LED = Setpoint 3
TTL	Total — blue LED is lit briefly, indicating the total weight is displayed.
NET	Net — indicates the scale is in net weight mode. Tare weight has been subtracted from gross weight.
PK	Peak — indicates the scale is in peak hold mode.
kg	kg — red LED indicates weight display is in kilograms.
lb	lb — red LED indicates weight display is in pounds.
x1K	X1000 — blue LED is used in conjunction with the TOTAL LED, allowing weight accumulation beyond the 5-digit display capacity.
■	Acknowledge — green LED is used to provide feedback to the operator that incoming remote commands have been received. Also used for acknowledging successful Auto-Total operations.
88888	The main display digits include five, 1.2" (30.5 mm) brightness LED load display.

Table 1-2. Annunciators and LEDs

2.0 Installation

The *MSI-4260 IS* features a heavy duty, cast aluminum enclosure. It installs easily by hanging it on a crane using properly sized shackles.



Refer to the Crane Scale Safety and Periodic Maintenance Manual (PN 153105) for safe loading and rigging guidelines when installing the model MSI-4260 IS.

Regular maintenance inspections of the lifting system should be performed to ensure safety. Pay particular attention for signs of stress on any element in the load train.

Use the appropriate interface hardware for the capacity of the scale.

- If the interface hardware does not fit properly, Rice Lake Weighing Systems can supply the *MSI-4260 IS* with oversize lifting eyes or shackle interfaces.
- If the crane hook is too large to fit in the lifting eye with single point interface, then install the scale using adaptive rigging.
- If multiple attachments are needed, use a shackle or ring to attach the multiple lines to keep a single point attachment to the scale.

IMPORTANT

Using an oversize shackle or hook to interface with the MSI-4260 IS can cause off center loading and stress points that will reduce the life of the lifting eye or hook.

Single point attachments are necessary to ensure the safety and accuracy of the scale system.

2.1 Unpacking

When unpacking the *MSI-4260 IS*, ensure that all assembly parts are accounted for. Check the *MSI-4260 IS* for any visible damage. If any parts were damaged in shipment, notify Rice Lake Weighing Systems and the shipper immediately. If the *MSI-4260 IS* must be returned, it must be properly packed with sufficient packing materials. Whenever possible, use the original carton when shipping the unit back.

2.2 Battery Pack

The *MSI-4260 IS* is powered by a 12V Sealed Lead Acid (SLA) rechargeable battery.

A spare battery pack is recommended to keep the *MSI-4260 IS* in continuous operation due to an extended battery charge time.



Only an Intrinsically Safe Battery, PN 167777, can be used with the MSI-4260 IS. This battery is incompatible with non-Intrinsically Safe MSI products. Refer to the Conditions of Use in Hazardous Locations document, PN 184530, for intrinsic safety information on the battery.

IMPORTANT

To obtain maximum service life from the batteries they should be stored between -4°F and 122°F (-20°C and +50°C). Stored batteries should be recharged every three months. The battery is fully charged when the status indicator on the battery charger is flashing.

2.2.1 Battery Life

The battery life of the *MSI-4260 IS* depends on a number of factors:

- The brightness of the LED display and number of segments lit
- The age of the battery
- The condition of the SLA battery

In order to conserve battery life, the *MSI-4260 IS* includes the following features.

- *Automatic Power Off Mode* — senses no activity after the set amount of minutes and turns the scale off
- *Automatic Sleep Mode* — dims the display after a set amount of minutes of no scale activity

The *MSI-4260 IS* automatically turns off when the SLA battery drops to approximately 10.5V. Recharge the battery when this happens; SLA batteries benefit from frequent recharging and can be recharged when it still has available life.

Due to the maintenance discharge imposed on the battery by the *MSI-4260 IS* electronics, do not store the *MSI-4260 IS* with the battery inside. Remove the battery if it will not be used for more than two weeks.

IMPORTANT

Leaving a discharged battery in the scale, which has a maintenance battery drain, can result in a deep discharged battery which will shorten its service life.



* If the scale is in continuous use, a fully charged spare battery is recommended. Replace the drained battery as close as possible to the low battery warning.

* SLA batteries that have not been deep discharged should withstand 500 to 1500 charging cycles.

* The low battery warning annunciator indicates about two to four hours of additional use before the MSI-4260 IS turns itself off.

* If the MSI-4260 IS is not going to be used again soon, remove the SLA battery to prevent deep discharge while the unit is in storage.

2.2.2 Battery Charger

The MSI-4260 IS is shipped with a battery charger, PN 170606, designed to charge and maintain the battery. Exact charging time will depend on the degree of discharge of the battery. A battery removed when the low battery warning first appears should take about eight hours to fully charge.



When the battery is new, it might take significantly longer for the initial charge. It is recommended to charge a new battery for 24 hours. It might take several charge/discharge cycles before full capacity is reached. Deep discharged batteries will also take significantly longer to charge.



The battery charger is not certified for use in hazardous environments. The battery must be removed and charged in a non-hazardous area. Refer to the Conditions of Use in Hazardous Locations document, PN 184530, for intrinsic safety information.

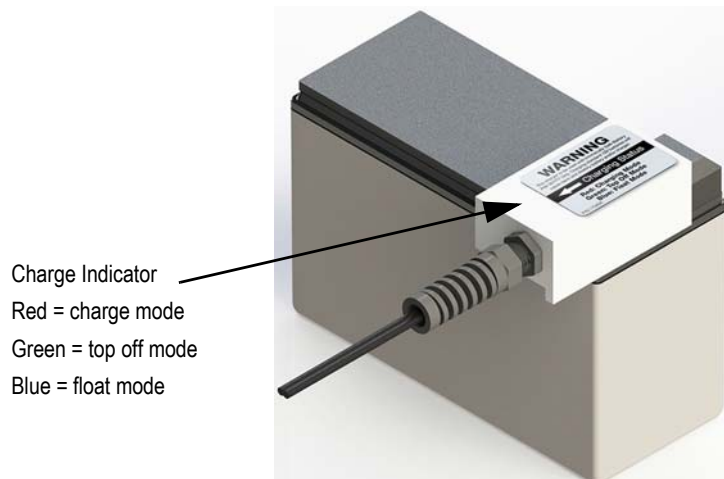

Figure 2-1. Battery Charger Connected to Battery

The battery charger is a universal input type that is a three-stage float charger that can be left on the battery indefinitely. It is rated for 100-240VAC, 50-60Hz. It has a tricolor LED to indicate the charging state.

- Red – charge mode
- Green – top off mode
- Blue – float (fully charged) mode

If the status light remains green when the battery is first plugged in, the battery may be defective.

Use the following steps to charge a battery.

1. Remove the battery from the MSI-4260 IS. See [Figure 2-2 on page 7](#).
2. In a safe environment, plug the polarized connector into the jacks on the battery.
3. Connect the charger assembly to an AC power supply (86-260VAC).



Unless the battery charger is first connected to the battery before plugging it into an AC power supply, the battery charger will be stuck in float mode and will not charge the battery. This will not cause any damage to either the charger or the battery. The charger will work properly if it is disconnected from the AC power and then plugged into the AC power again after waiting for 30 seconds.

4. The charge status light should turn *RED* indicating bulk charging.
5. Charge until the status light turns *GREEN*. This indicates the charger is in top off mode. The battery has sufficient charge for use, but continuing to charge until the status light turns *BLUE* will ensure that the battery has a full charge.
6. The charger and battery are in float charge mode when the charge indicator turns *BLUE*.

When the charge cycle is complete, the battery can be left on the charger until it is needed. The charger keeps a maintenance float charge on the battery to ensure the best possible operation times.

IMPORTANT

To obtain maximum service life from your batteries, the manufacturer suggests recharging after each 20 hours of use. Continuous deep discharging will reduce maximum battery life cycle estimated at 2000 cycles.

2.2.3 Battery Replacement

1. Turn the *MSI-4260 IS* off.
2. Hold the battery cover and release the latches.
3. Slowly lower the cover while holding the battery in place.
4. Remove the battery by pulling straight back.
5. Charge the spent battery in a safe area.
6. Install a fully charged battery by plugging it in to the exposed battery jacks.
7. Close the battery cover.
8. Reset the latches. Make sure the latches are completely latched and the cover is firmly in place.



Figure 2-2. Remove Battery



Periodically, inspect the battery latches for fit. Adjust the screw latch by rotating the catch on its threads to maintain a tight seal on the battery o-ring. The 12V Sealed Lead Acid battery can be a falling hazard. When opening the battery hatch, be sure to hold the battery to prevent it from falling.

These batteries contain lead and should be recycled in accordance with procedures approved by state and local authorities when their end of life is reached.

Only an Intrinsically Safe Battery, PN 167777, can be used with the MSI-4260 IS. This battery is incompatible with non-Intrinsically Safe MSI product. The intrinsically safe battery pack can be removed in the protected area, but must be charged in a safe environment.





2.3 Servicing

The entire scale must be shipped back to Rice Lake Weighing Systems for repair. Please contact a local dealer or Rice Lake Weighing Systems to obtain a return material authorization (RMA). There are no user serviceable parts within the *MSI-4260 IS*. All repairs are to be performed by qualified service personnel only. Removing the warranty and liability label compromises the FM rating.

3.0 Operation

The following sections describe the basic operation of the *MSI-4260 IS*.

3.1 Navigation of Menus

- If a function key does not work, it is probably because the *MSI-4260 IS* is not set up to support the key. For example, if the function key is set for **TOTAL**, the **TOTAL** mode must also be set up in the Setup Menu.
- When in Setup menus,  drops back one menu level. At the root menu level, the  stores the changes and returns to the weight mode.
- When in Setup menus,  returns directly to the Weight Display without storing the changes.
- When in Setup menus,  functions as the scroll key.
- When in Setup menus,  functions as the **ENTER/SELECT** key.

3.2 Power

To turn on the power, press . The following will display in order:

- The LEDs will light all segments at full brightness as a display test.
- Display brightness will change to the setting determined in the Display Menu.
- The software version number will display.
- The *MSI-4260 IS* is ready for use.

3.3 Zero

The zero key sets the zero reading of the scale. Press  to take out small deviations in zero when the scale is unloaded. See Section 3.4 for zeroing (taring) a package or pallet weights.



The scale digits display 0 (or 0.0 or 0.00, etc).

The backup memory in the MSI-4260 IS stores the zero reading and retains it even if the power fails.

Rules for Use:



- Works in *GROSS* or *NET* mode.
- Zeroing while in net mode will zero the gross weight causing the display to show a negative tare value.
- The scale must be stable within the motion window. The *MSI-4260 IS* will only zero if the stable annunciator is on and there has been no activity of two seconds.
- The scale will accept a zero setting over the full Range of the scale (NTEP and other Legal for Trade models may have a limited zero range). Zero settings above four percent of full scale will subtract from the overall capacity of the *MSI-4260 IS*.

Example: If 100 lb on a 1000 lb scale is zeroed, the overall capacity of the scale will reduce to 900 lb, plus the allowed over-range amount.

3.4 Tare

Tare is used to zero out a known weight such as a packing container or pallet and display the load in NET weight.

A tare value is entered by pressing . The TARE function is defined as a Tare-In, Tare-Out operation.

The first press of  stores the current weight as a tare value and then the scale subtracts the tare value from the gross weight and changes the display to NET mode. The next press of  will clear the tare value and revert the display to GROSS mode.

To view the gross weight without clearing the tare value, program  to the function NET/GROSS.

The RF remote control has a net/gross permanently available.

To tare and display the net weight, press .



The weight reading must be stable within the motion window for the tare function to work.

The scale digits display 0 (or 0.0 or 0.00, etc) and the weight mode changes to NET.

The backup memory in the MSI-4260 IS stores the tare reading and can restore it even if power fails.

To clear the tare and revert to gross weight, press . GROSS displays.







- Only positive gross weight readings can be tared.
- The  must be off indicating weight reading is stable.
- Setting or changing the tare has no effect on the gross zero setting.
- Taring will reduce the apparent over range of the scale.

Example: Taring a 100 lb container on a 1000 lb scale, the scale will overload at a net weight of 900 lb (1000-100) plus any additional allowed overload (usually ~four percent or 9d).



- The scale stores the tare value in non-volatile memory and is restored when power is cycled.

4.0 Setup

The following keys can be used when navigating through the menus while setting up the *MSI-4260 IS*.

- Press  to exit setup without saving changes. *CRANE* displays momentarily and unit enters weigh mode.
- Press  while the digit is blinking to enter a decimal point.
- Press  to save and go back one level. Press it again to leave the setup mode, *STORE* will display briefly when entering weigh mode.
- Press  to step back one digit and press  to change the digit if a wrong value is entered.
- Press  to enter or select a parameter.
- Press  to scroll through the parameters.

4.1 Setup Menu

To enter into the *MSI-4260 IS* setup menu, press  and  simultaneously.

Parameters	Choices	Description
Func 1 Func 2	OFF	Function User Key 1 – user definable key that can be programmed to one of several functions Function User Key 2 – Not Available
	TEST	Test Display – see Section 4.1.2 on page 11
	TOTAL	Total – see Section 4.1.3 on page 12
	VIEW TOTAL	View Total – see Section 4.1.4 on page 12
	NET/GROSS	Net/Gross – see Section 4.1.5 on page 12
	LEARN	Not Available
	P-HOLD	Peak Hold – see Section 4.1.7 on page 12 Function not available or non-functional in OIML R76 or NTEP HB44 modes
	UNITS	Units – see Section 4.1.8 on page 12 Function not available or non-functional in OIML R76 & 1Unit modes
	PRINT	Print – see Section 4.1.9 on page 12
	R-OFF	OFF 15 30 45 60
SLEEP	OFF 5 15 30	Sleep – Time (in minutes) before unit enters the sleep mode See Section 4.3 on page 13
DISPL	LD-1 LD-2 HI-1 HI-2 AUTO	LED Display Intensity – used to set the display brightness See Section 4.4 on page 14
SETPt 1-3	OFF GREAT LESS	Setpoints 1-3 – used for warnings or process control See Section 4.5 on page 14







Table 4-1. Setup Menu Parameter Descriptions



Parameters	Choices	Description
total	OFF t.tOn R. Load R. LRS R. H.GH	Total Mode – accumulation of multiple weighments See Section 4.6 on page 16
Filter	OFF LO H. - 1	Weight Filter – allows the scale to adjust to situations where there may be movement See Section 4.7 on page 17
Unit	Lb HG	Weight Units – toggle units between pounds and kilograms Function not available or non-functional in OIML R76 & 1Unit modes See Section 4.8 on page 17
baTtE	Stand Long	Battery Life – sets the options for standard or extended battery life. See Section 4.9 on page 17

Table 4-1. Setup Menu Parameter Descriptions

4.1.1 Set Function Key

The *MSI-4260 IS* has one user definable key () on the front panel, that can be programmed to one of several functions. To set the function key use the following steps:

1. Press and hold  and . *Func 1* is displayed.
2. Press . The current user key function is displayed.
3. Press the  to scroll through the available functions.
4. Press  when the desired function is displayed. *Func 2* displays.
5. Press . *StorE* displays, the unit exits setup and stores the settings.

 **Note** Press  at any time to cancel the procedure.

4.1.2 Test

To run a test, press the F key which is programmed to *TEST*. The display automatically scrolls through the following:

- Lights all LEDs at once.
- Displays *Soft* followed by the software version number.
- Displays *bAtt* followed by the battery voltage.
- Displays *d.tEst* followed by the display counting from 00000 to 99999.
- Displays *C-CAL* followed by the C-CAL value.











Other internal tests are performed and if any test fails, an error code displays. See Section 6.1 on page 23 for information on the troubleshooting guide.

To stop the automatic test procedure, press the F-key again within two seconds to enable a single step mode. Use the F-key to scroll through the available test functions and  to start or display the individual tests.

Press  to exit individual tests, press it again to exit from the test function.

4.1.3 Total

Set the total parameter desired for the F-key.

1. If the unit is turned off, press and hold  then press .
If the unit is on, press  and  simultaneously. *Func 1* displays.
2. Using the , scroll to *TOTAL*.
3. Press . The currently saved total mode displays.
4. Press  to scroll through the choices.
5. With choice displayed, press  to select. *Func 1* displays.
6. Press  to save and exit to weighing mode or press  to continue to another setup menu item.



Note The total mode must be programmed from the setup menus before the USER key will function.

4.1.4 View Total

The F-key activates the total weight display followed by the number of samples. With the total weight is displayed press ZERO to clear.

4.1.5 Net / Gross

Switches the display between net and gross modes. Net weight is defined as gross weight minus a tare weight.

To switch between net mode and gross mode, press the F-key (set to net/gross function). This will only work if a tare value has been established.

The operator can switch back to gross from net without clearing the tare value. Only clearing or setting a new tare will change the tare value held before switching into gross mode.

OIML Legal for Trade units only: The **NET/GROSS** key is a temporary action only. The gross weight is displayed for two seconds and then the display returns to the net mode. The only way to return to permanent gross readings is to clear the tare. See Section 3.4 on page 9.

4.1.6 Learn

This option is not available in the Factory Mutual version of the *MSI-4260 IS*.

4.1.7 Peak Hold

Peak hold will only update the display when a higher peak weight reading is established.

The peak hold function uses a high speed mode of the A/D converter allowing it to capture transient weights at a far higher rate than typical scales. Peak hold is cleared and re-enabled with the F-key.

Peak hold is not available on NTEP or OIML Legal for Trade certified scales.

4.1.8 Units

Units can be changed in two ways.

- Program a user function key to units
- Change the units with the setup menu using the following steps



Note *Unit switching is not available on OIML certified Legal for Trade scales.*







4.1.9 Print



Not available in the *MSI-4260 IS*.

4.2 Auto-Off

The Auto-Off feature prolongs the battery life by powering off the unit when not in use. Whenever a button is pressed or the detected load is in motion exceeding 10d, the time limit is reset. When disabled, the unit will remain on and only turn off when the power key is pressed or the battery dies.

Use the following steps to set the Auto-Off function:







1. Press and hold  and . *FUNC 1* displays.
2. Press the  to scroll to *A-OFF*.
3. Press . The current *A-OFF* time displays.
4. Press the  to scroll through the available times.
5. Press  when the desired time displays. *SLEEP* displays.
6. Press  to exit setup and store the settings.



 **Note** Press  at any time to cancel the procedure.

4.3 Sleep

The Sleep parameter reduces power consumption by automatically turning off the display during periods of inactivity. While in the sleep mode, the green acknowledge annunciator blinks at a one second rate to indicate the unit is in sleep mode. To wake up the unit, either a button must be pushed (front panel) or the weight must change by 5 d or more.

 **Note** *Sleep must be set to less time than the Auto-Off timer.*

1. Press and hold  and . *FUNC 1* displays.
2. Press the  to scroll to the *SLEEP* function.
3. Press . The current *SLEEP* time displays.
4. Press the  to scroll through the available times.
5. Press  when the desired time displays. *d SPL* displays.
6. Press  to exit setup and store the settings.





 **Note** Press  at any time to cancel the procedure.

4.4 Display Brightness



The Display setup menu is used to set the display brightness. There are four fixed brightness settings and one automatic light sensing brightness setting.



Auto setting will automatically detect the ambient light and adjust the brightness of the display accordingly. Bright light will cause the display to be at the brightest setting. The display brightness will reduce as ambient light reduces.

There are four fixed brightness settings, *LO-1*, *LO-2*, *HI-1* and *HI-2*. Lower brightness settings increase battery life.

1. Press and hold  and . *FUNC 1* displays.
2. Press the  to scroll to the *d ISPL* function.
3. Press . The current *d ISPL* setting displays.
4. Press the  to scroll through the available settings.

 **Note** *The display brightness changes when each setting displays.*

5. Press  when the desired setting displays. *5tPt 1* displays.
6. Press  to exit setup and store the settings.

 **Note** Press  at any time to cancel the procedure.

4.5 Setpoints

The *MSI-4260 IS* supports three setpoints. Common uses of set points are for warnings or process control. It comes standard with LED outputs for a triggered set point.



Setpoint 1 is Blue
Setpoint 2 is Green
Setpoint 3 is Red











Figure 4-1. Setpoint LED's

Contact Rice Lake Weighing Systems for other setpoint output options which are displayed below.



Setpoint	Description
Setpoint Mode	
<i>GrEAt</i>	Indicates the setpoint will trigger when the weight exceeds a set value
<i>LESS</i>	Indicates the setpoint will trigger when the weight is less than a set value
Setpoint Weight Type	
<i>netGr</i>	Responds to net or gross weight
<i>Gross</i>	Responds to gross weight regardless of the display
<i>total</i>	Responds to the totaled weight
<i>tcnt</i>	Responds to the total count (number of samples)
<i>lfcnt</i>	Responds to the number of times the weight has exceeded 25% of capacity



Table 4-2. Available Setpoint Settings

To set the setpoint:

1. Press and hold  and . *FUnC 1* displays.
2. Press  to scroll to the desired setpoint (*SEtPt 1*, *SEtPt 2*, *SEtPt 3*).
3. Press . The current *SEtPt* mode displays.
4. Press  to scroll to the setpoint mode desired.
5. Press . The current *SEtPt* weight type displays.
6. Press  to scroll to the desired weight type.
7. Press . The current setpoint weight value displays.
8. Press . The first digit blinks.
9. Press  to scroll to the desired number.
10. Press . The second digit blinks.
11. Repeat steps 8-10 until the desired value displays.

 **Note** To enter a decimal point, press  while the digit is blinking. To correct a digit, press  to step back.

12. Press . The value stops blinking and the next setup menu item displays.
13. Repeat steps 2-12 to set all the setpoints to be used.
14. Press  to exit setup and store the settings.

 **Note** Press  at any time to cancel the procedure.

4.6 Total

For the accumulation of multiple weighments, the total function uses the displayed load, so gross and net readings can be added into the same total.

There are four modes of totalizing: manual and three auto modes. The manual mode requires the **TOTAL** key be pressed with the weight on the scale. The weight is added to the previously accumulated value. This assures that a weight on the scale is only added to the total once.

Both the manual and three auto total modes require that the weight on the scale return below 0.5 percent (relative to full scale) of *GROSS ZERO* or *NET ZERO* before the next weighment can be added. Applied weight must be ≥ 1 percent of full scale above *GROSS ZERO* or *NET ZERO* before it can be totaled.

Manual Total

The **USER** key under the Manual Total mode functions in this manner:

- **Weight is greater than one percent of capacity and has not been totaled** – Pushing the **USER** key will add the current weight to the TOTAL weight. The ACK LED's blink to indicate the weight was accepted. The *TOTAL* annunciator lights and the Total weight is displayed for five seconds and then the number of samples is displayed for two seconds.
- **Current Weight has been totaled** – Pushing the **USER** key will display the Total weight for five seconds (View Total) without changing the Total value. The *TOTAL* annunciator will light during the TOTAL weight display. After five seconds of Total Weight display, the number of samples is displayed for two seconds.
- **Weight is less than one percent of capacity** – The **USER** key functions as View Total only and functions as View Total until the one percent threshold is exceeded to allow the next addition to the total value.

Auto Total



The **USER** key under the AUTO TOTAL mode functions as Auto Total On / Auto Total Off.

The Auto Mode has three variations which are programmed in the Setup menu:



- **A. Load** – AutoLoad ensures any settled load above the *Rise above* threshold will be automatically totaled. The scale must fall below the *Drop below* threshold before the next total is allowed.
- **A. Last** – AutoLast mode takes the last settled weight to auto total with. The total occurs only once the scale goes below the threshold. This allows the load to be adjusted without a total occurring. Once the load is removed, the scale uses the last settled reading for total.
- **A. High** – AutoHigh uses the highest settled reading. This is useful for loads that can't be removed all at once.







Note

Total Mode will not function while the scale is in motion, make sure   is on. If the system fails to achieve stable readings, increase the filter setting or increase the size of the scale division (d) in the Init Cal procedure.

Set Total Mode

1. If the unit is turned off, press and hold  then press .

If the unit is on, press  and  simultaneously. *Func 1* displays.











2. Using the , scroll to *total*.
3. Press . The currently saved total mode displays.
4. Press  to scroll through the selections.
5. With selection displayed, press  to select. *Full* displays.

Press  to save and exit to weighing mode or press  to continue to another setup menu item.









4.7 Filter Setup

Changing the filter settings allows the scale to adjust to situations where there is a lot a movement in the structure. If the reading is not stable, it can often be improved by increasing the filter setting. Settling time will be longer as the filter setting is increased. However, the *MSI-4260 IS* employs algorithms that speed up large weight changes while still controlling vibration even with high filter settings.











Use the following steps to set up filtering.

1. If the unit is turned off, Press and hold  then press 
If the unit is on, press  and  simultaneously. *Func 1* displays.
2. Using the , scroll to *totAL*.
3. Press . The currently saved total mode displays.
4. Press  to scroll through the selections.
5. With selection displayed, press  to select. The next item in the setup menu displays.
6. Press  to save and exit to weighing mode or press  to continue to another setup menu item.

4.8 Units

1. Press and hold  and then . *Func 1* displays.
If the unit is on, press  and  simultaneously. *Func 1* displays.
2. Using the , scroll to *Unit*.
3. Press . *Unit* displays.
4. Press  to scroll through the selections.
5. With the desired selection displayed, press  to select.
6. Press  to save and exit to weighing mode.

4.9 Battery Life

1. If the unit is turned off, press and hold  then press 
If the unit is on, press  and  simultaneously. *Func 1* displays.
2. Using the , scroll to *b. L iFE*.
3. Press . The currently saved mode displays.
4. Press  to toggle between the selections.
5. With selection displayed, press  to select. *Func 1* displays.
6. Press  to save and exit to weighing mode or press  to continue to another setup menu item.

5.0 Calibration

The *MSI-4260 IS* is calibrated using standard weights. It is required that the weight used is at least 10 percent of full capacity in order to achieve rated accuracy. For example, use at least a 500 kg test weight to calibrate a 5000 kg capacity scale. Although a single span point is usually adequate for rated accuracy, the *MSI-4260 IS* supports Multi-Point calibration with up to four span points plus zero.

When adequate test weights are not available, the *MSI-4260 IS* can be calibrated using a calculated constant calibration which is referred to as C-Cal. To use C-Cal, a previously generated C-Cal number must be known. MSI supplies replacement load cells for the *MSI-4260 IS* with the C-Cal value stamped on the serial number label.

There are three kinds of calibration:

- **Standard Calibration** – this is used for maintenance and routine calibration.
- **Initial Calibration** – is used to set up both the capacity and resolution (d) of the scale. It differs from standard calibration only in the initial steps. The initial calibration is performed after a calibration reset which completely erases the calibration and setup memory.
- **C-Cal** – If the last calculated C-Cal value is known, the *MSI-4260 IS* can be calibrated without weights.

5.1 Calibration Switch Access

Use the following steps to access the calibration switch on the *MSI-4260 IS*, if calibrating the unit using either the standard calibration or the C-Cal calibration.

1. Remove the hex seal screw from the *MSI-4260 IS*.

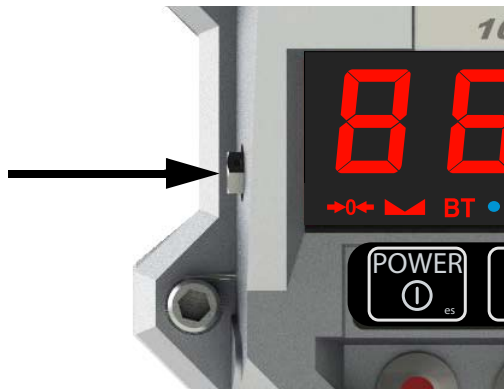





Figure 5-1. Calibration Switch Seal Screw

2. Using a small screwdriver, press the Cal switch located behind the hex seal screw. $\square RL$ displays.
3. Reinstall the hex seal screw. The screw must be torqued to 45.6 inch-lb to ensure the integrity of environmental seal.

5.2 Standard Calibration

Use the following steps to calibrate the *MSI-4260 IS* using the standard calibration procedure.





1. Press , $U n L d$ displays.
2. Press  when the scale becomes motionless. A blinking \square displays.
 - If the scale is in range $P A S S$ displays, then $L o A d I$ displays.
3. Load the scale with a test weight (for a single span point calibration, a test weight of more than 20 percent of capacity or more is recommended).
4. Press . The current capacity flashes on the display. If loading the scale with the capacity weight, skip to step 8.
5. Press  if using a calibration weight other than capacity. The far left digit on the display blinks, indicating a number should be entered.











6. Press  to scroll the numbers and  to enter each digit.
Example: Enter 2500 kg on a 5000 kg capacity scale.
 Press  two times for the leftmost blinking digit, press  to save that digit selection.
 Press  five times for the next blinking digit, press  to save that digit selection.
 Press  to save the next digit selection.
 Press  to save the next digit selection. 2500 displays.
7. Press  to save the weight entry. If the cal value is within limits, PASS is briefly displayed then Load2.
8. Press  if more cal points are desired or press  if a single point cal is needed.
9. Load the scale with the next test weight and press  if the weight value is acceptable.
10. Press  to scroll through digit selections and press  to enter the calibration weight value.
11. Press  again to complete the calibration span point. If the cal value is within limits, PASS displays briefly, then Load3 or Load4 displays.
12. Press  to enter an additional span point or  if finished. CRL d displays to indicate that the calibration was successful.
13. Press . C-CRL flashes followed by the C-CRL number.
14. Press  to store the calibration. SETUP displays.
15. Press  to exit the calibration menus and start up the standard weight display.
16. Replace the hex seal screw that was removed in “Calibration Switch Access” on page 18.

5.3 Initial Calibration

Use this procedure only if the capacity and count-by (d) need to be modified. The initial calibration erases user setup as well as any previous calibration.

Use the following steps to perform the initial calibration procedure.

1. Turn the MSI-4260 IS off.
2. Remove the hex seal screw using the steps in Section 5.1 on page 18.
3. Press the Cal switch and the Power switch on the unit simultaneously. rESEt displays.
4. Press  to reset the calibration constants. SETUP displays.
5. Press  to complete the reset. CRL displays.
6. Press  to start the initial calibration. Unit displays.
7. Press  to select the calibration unit.

8. Press  to choose between lb and kg and then press  .
9. Press  to enter the capacity setting. A capacity of 10000 is the initial value and should not be set higher than the load cell rated capacity.
10. Press  to change the capacity. The first digit on the display blinks.
11. Press  to scroll through the numbers and then press  when the desired number displays.
12. Press  to store the capacity value. *d* displays.
13. Press  to begin the scale divisions. Press  to scroll through the recommended scale divisions.
14. Press  when the desired scale division is displayed. *UNL d* displays indicating that the scale is ready for calibration.
15. Follow the standard calibration procedure in Section 5.2 on page 18 (starting with step 3) to calibrate the *MSI-4260 IS*.

5.4 Guidelines for Capacity and Resolution

Crane scales are subject to forces that regular floor scales do not see. Many bridge cranes, hoist cranes and mobile cranes lack rigidity and tend to bounce or swing when loads are lifted. For this reason, Rice Lake Weighing Systems recommends that the resolution is kept in the 1:2000 to 1:3000 range. Some improvement in stability can be achieved by increasing the filtering. Never program the resolution higher than needed. If the *MSI-4260 IS* display is never stable, it is recommended that the resolution is reduced and/or filtering increased.

Due to Legal for Trade requirements and general scale design criteria, the weight must be stable for certain features to work:

- ZERO – the weight must be stable to be zeroed.
- TARE – the weight must be stable to be tared.
- TOTAL – the weight must be stable to be added to the total registers.

One way to improve the stability is to increase the filtering, at the risk of increasing settling time. The other is to increase the 'd' (reduce resolution). The third way is to increase the Motion Window. The *MSI-4260 IS* defaults to $\pm 1d$ as a motion window. It can be changed at Rice Lake to a higher value if desired. Often $\pm 3d$ is chosen for bridge cranes as these tend to have a lot of bounce to them. This of course carries an accuracy penalty adding $\pm 3d$ to the total accuracy of the scale if the zero or tare operation happens to capture the weight in a valley or peak.

Setting capacity is dictated primarily by the capability of the load cell. Rice Lake supplies the *MSI-4260 IS* in many capacities.

IMPORTANT

Never set the capacity of the scale higher than the rating of the load cell.

Due to excellent linearity of the MSI S-Beam load cell, it is acceptable to set lower capacities to better match the crane that the *MSI-4260 IS* is used on. For example, if the hoist is rated for 9000 lb, then use a 10000 lb. weight and reset the capacity to 9000 lb. Use the Initial Calibration procedure for this calibration. De-rating as much as 50 percent of the capacity is usually acceptable, but the scale may be less stable if the *d* is decreased.

Due to kg to lb conversions, the capacity of all *MSI-4260 IS* systems is rated approximately 20 percent higher than the rated capacity in pounds. This is to allow the kg capacity to be exactly 1/2 the number of the pound capacity.

5.5 C-Cal Calibration







When adequate test weights are not available, the *MSI-4260 IS* can be calibrated using a programmed constant calibration which is referred to as C-Cal. To use C-Cal, a C-Cal number must be known from a previous calibration. MSI supplies replacement load cells for the *MSI-4260 IS* with the C-Cal value stamped on the serial number label. When a calibration is performed with test weights, a new C-Cal is generated. C-Cal can be used when the electronics are replaced to get an approximate calibration that may be suitable for non Legal for Trade applications.

IMPORTANT



The C-Cal number must be known prior to starting this procedure. For an MSI-4260 IS with its original load cell, MSI prints this number on the calibration record, the serial number tag and on the calibration log found inside the battery compartment.



C-Calibration reduces the accuracy of the system if the electronics are replaced or a new load cell is installed. Legal for Trade installations require that the *MSI-4260 IS* is calibrated using test weights. If a system was originally multi-point calibrated, the C-CAL calibration will erase the additional span points, as C-Cal is only a two point calibration (zero and span at 10% of capacity).

Use the following steps to perform a C-Cal calibration.





1. Remove the hex seal screw from the *MSI-4260 IS* using the steps from Section 5.1 on page 18.
2. Press  to scroll to the C-Cal menu selection. $\bar{C}-\bar{C}AL$ displays.
3. Press  to start the C-Cal procedure. $UNLd$ displays indicating that all weight should be removed from the hook.
4. Press  to set the zero calibration point. A flashing $\bar{0}$ displays.
 - If the zero is in range, $PASS$ displays briefly and then $\bar{C}CALP$ displays.
5. Press . An *MSI-4260 IS* is ready for numeric entry of the C-Cal value.
6. Press  to enter the C-Cal value. The far left digit on the display flashes.
7. Press  to scroll the numbers. Press  to enter each digit.

Example: Enter 2500 kg on a 5000 kg capacity scale.

Press  two times for the leftmost blinking digit, press  to save that digit selection.

Press  five times for the next blinking digit, press  to save that digit selection.

Press  to save that digit selection.

Press  to save the next digit selection. 2500 is displayed.
8. Press  to save the C-Cal value. $PASS$ displays briefly followed by $\bar{C}AL d$.
9. Press  to exit C-Cal setup menu.
10. Press  again to store the calibration and return to the scale operation. $STOR E$ displays.

5.6 Calibration Setup Menu

The Calibration Setup Menu contains two additional items beyond Calibration:

- Standard menu
- Auto Zero Maintenance menu – *Auto0*.







Additional menus display that are transferred from the main setup menu when Legal for Trade settings are used.

5.6.1 Standard Menu

Selection	Description
Industrial (indu5)	This is the most common setting for the <i>MSI-4260 IS</i> . With the Industrial standard, there is full range zero, access to units switching, filters, and peak hold.
Handbook 44 (Hb-44)	Sets the scale to enable only approved features per the NTEP HB-44 rules and regulations. Access is denied to peak hold, and the zero range may be limited. The Filter menu is moved to the Cal Setup menu, so filters are only accessible through the cal seal.
R-76 (r-76)	Sets the scale to enable only approved features per OIML R-76. Only kg weight units are available. The zero range is limited to 4% (-1 to +3% relative to Calibrate zero). Net/gross function is temporary. Once net weight is established, pushing an F key set for net/gross will cause a maximum 5 second display of the gross weight. Clear the tare to display gross weight continuously. Other metrological aspects are changed to meet R-76 requirements.
One Unit (1unit)	The one unit Standard is the same as Industrial, except units switching is inhibited. This is useful for metric only countries. Another use of the one unit standard is to allow the scale to be calibrated in units other than lb or kg, since conversions are eliminated. Contact MSI for more information on the standards settings.

Table 5-1. Standard Menu Selections







Use the following steps to set up a Legal for Trade standard settings.

1. Remove the hex seal screw from the *MSI-4260 IS* using the steps from Section 5.1 on page 18. and $\square RL$ displays.
2. Press . $SEtUP$ displays.
3. Press  to enter the Cal setup menu.
4. Press  to enter the standard menu. The current standard setting displays.
5. Press  to scroll to the desired standard. $1 Un it$ displays.
6. Press  to set the standard. $AutoCAL$ or the next item in the CAL setup menu displays.
7. Press  twice to exit setup and store all changes. $StorE$ displays.

5.7 Auto Zero Maintenance

The *MSI-4260 IS* employs an Auto Zero Maintenance (AZM) mechanism to adjust the zero reading to the center-of-zero, which is defined as the weight reading within 1/4 d of zero. AZM continuously adjusts zero to maintain the center-of-zero. It is recommended that AZM is on to maintain the highest accuracy. However, there are circumstances when it should be turned off. This can happen when minor variations of weight occur while picking up scale attachments and the variations fall within the AZM capture window. The AZM capture window (usually 1 d) and capture time (usually eight seconds) can be adjusted by MSI to meet custom requirements. The settings of AZM are dictated in Legal for Trade standards and cannot be adjusted.

Use the following steps to set up the auto zero maintenance.

1. Remove the hex seal screw from the *MSI-4260 IS* using the steps from Section 5.1 on page 18. $\square RL$ displays.
2. Press . $SEtUP$ displays.
3. Press  to enter the Cal setup menu. $StAnd$ displays.
4. Press  to scroll to the Auto0 menu. $Auto0$ displays.
5. Press  to enter the Auto Zero menu. The current setting displays and is flashing.
6. Press  to scroll between the on or off key.
7. Press  to set the auto zero. $StAnd$ displays.
8. Press  twice to exit setup and store all changes. $StorE$ displays.

6.0 Troubleshooting / Maintenance

6.1 Troubleshooting

Problem	Possible Cause	Solution
The display is blank when the POWER button is depressed	Discharged battery	Recharge the battery. Allow at least four hours charge
	Defective battery	Replace the battery
	Corroded battery or battery contacts	Clean the battery contacts
	Defective switch or circuit board	Requires authorized service
The display does not function properly, the front panel button does not function normally or the scale will not turn off	Improperly updated software	Reinstall the software
	Faulty circuit board	Requires authorized service
	Loose connectors	Requires authorized service
The scale does not respond to weight changes	Out of calibration	Calibrate the unit
	Faulty load cell	Replace the load cell
	Load cell connector	Check the connector and wires
The display over ranges below 100% capacity	Tared weight added to load to determine overload point	Return to gross weight mode
	Zero requires adjustment	Rezero the scale
	Too much weight has been zeroed	Rezero the scale
The display drifts	AZM (Auto0) is turned off	Turn AZM on
	Rapid temperature changes such as moving the scale from indoors to outdoors	Wait until the scale temperature has stabilized
The displayed weight shows a large error	Scale not zeroed before load is lifted	Zero the scale with no load attached
	lb/kg units causing confusion	Select the proper units
	Requires recalibration	Recalibrate the unit
The display reading is not stable	Excessive vibration in crane system	Increase filtering or increase 'd' in Cal
	Excessive side loading	Improve load train symmetry
	Load cell faulty	Check the load cell connections
The display toggles between <i>Error</i> and <i>Load</i>	Weight exceeds capacity	Reduce weight immediately
	Faulty load cell or wiring	Check load cell and load cell wiring
The display toggles between <i>Error</i> and <i>Under</i>	Weight in below the zero range.	If the scale is in compression, remove the source
	Calibration faulty	Recalibrate
	Faulty load cell or wiring	Check the load cell connections
The display toggles between <i>Error</i> and <i>AdLo</i>	A/D is saturated negative	Check the load cell and load cell wiring
Display toggles between <i>Error</i> and <i>Button</i>	A key is stuck or is being held down	Check switches for damage
<i>Lo</i> <i>Button</i> is blinking	The battery is low	Recharge the battery
Unit turns on, then immediately turns off	The battery is low	Recharge the battery
Weight will not zero	The system not stable	The stable annunciator must turn on for Zero to function; Increase the filtering for more stability
	Zero is out of range	Increase the filtering for more stability Legal for Trade units have limited zero range. Reduce the weight or use Tare instead
The weight will not Zero, Tare or Total	The system is not stable	Wait for Stable annunciator to turn on, or if in a mechanically noisy crane, increase the filtering or increase the size of the scale increment d; It is also possible to increase the motion window; Contact MSI if there is a problem getting the <i>MSI-4260 IS</i> to zero, tare, or total due to stability issues
Setpoint lights blink	Setpoint is enabled and the trigger point has been reached	Disable set points if they are not needed
Manual total does not work	A Function key is not set to Total	Set up Func1 or Func2 for Total
	The weight must be stable	Increase filtering for more stability

Table 6-2. Troubleshooting

Problem	Possible Cause	Solution
Auto Total does not work	The weight must be stable	Wait for the stable annunciator to turn on, or Increase filtering for more stability
	Weight thresholds not reached	They must exceed 1% of capacity for autototal to work; Then you must drop below 0.5% of capacity for additional weighments to register

Table 6-2. Troubleshooting (Continued)

6.2 Service Counters





Only an MSI factory representative can reset the service counters, as these are an important safety warning feature. A thorough load train inspection is necessary to ensure product safety.

The MSI-4260 IS maintains two service counters for safety.

- The first counter counts the number of times the scale has been overloaded
- The second counter counts lifts above 25 percent of capacity

These counters serve to warn the user to inspect the load train after a number of overloads and also when there is a chance of fatigue failure. The power up routine will be interrupted when the lift counter exceeds 16383 lifts or the overload counter exceeds 1023 overloads. If the screen displays $LF\overline{L}$ when unit is powered on:







1. Push  to display the 25% lift counter.
2. Push  again to see the overload lift counter.
3. Push the  key to acknowledge the warning and return to standard scale operation.



The power up warning message won't appear again for another 16383 lifts (or 1023 overloads).

6.2.1 Access the Service Counters:

Use the following steps to access the service counters.

4. Program a user function key to be $\overline{E5\overline{E}}$ (see Section 4.1.1 on page 11).
5. Press .
6. Press  within two seconds. The display flashes
 - $LF\overline{L}$ (for Lift Counter) followed by the number of times the weight has exceeded 25% of capacity
 - $\overline{OL\overline{L}}$ (for Overload Counter) followed by the number of times the weight has exceeded capacity
 - $\overline{C-CAL}$ followed by the C-Cal value
 The display then returns to the weigh mode.
 To stop the scrolling and step through them proceed to step 7.
7. Press  immediately after  is pressed.
8. Press  to scroll through counters.
9. Press  to enter the counter, the value displays.
10. Press  to return to weigh mode.



The service counters are important safety warning features, only an MSI factory representative should reset the service counters. A thorough load train inspection may be necessary to ensure user safety.

After the service counters are viewed a few times, the automatic warning stops, but the counters continue to monitor lifts.

Refer to the Crane Scale Safety and Periodic Maintenance manual (Pub. 243-08-94D) for proper loading techniques to improve the safety and longevity of the MSI-4260 IS crane scale. This publication is available at www.ricelake.com and is included in the CD shipped with your crane scale.



The power up warning message won't appear again for another 16383 lifts (or 1023 overloads).

6.3 MSI-4260 IS Port-A-Weigh Dimensions

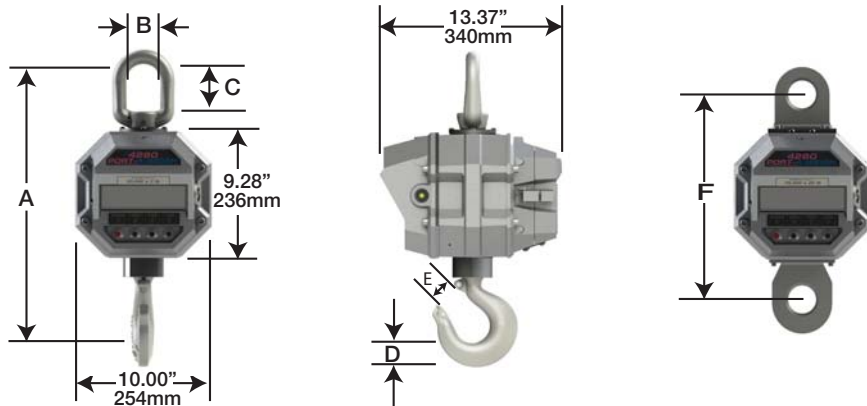

Capacity	Resolution**	A*	B*	C*	D*	E*	F	Hook	Eye Nut or Shackle	Safety Factor	Shipping Wt
500 lb 250 kg	0.2 lb 0.1 kg	18.3 in 465 mm	2.25 in 57.1 mm	3.06 in 77.7 mm	1.44 in 37.0 mm	1.41 in 36.0 mm	-	5 ton alloy swivel	CR# 7 eyenut	>5	53 lb 24 kg
2,000 lb 1,000 kg	1 lb 0.5 kg	18.3 in 465 mm	2.25 in 57.1 mm	3.06 in 77.7 mm	1.44 in 37.0 mm	1.41 in 36.0 mm	-	5 ton alloy swivel	CR# 7 eyenut	>5	53 lb 24 kg
5,000 lb 2,500 kg	1 lb 0.5 kg	20.5 in 521 mm	2.50 in 64.0 mm	3.50 in 89.0 mm	1.81 in 46.0 mm	1.69 in 42.9 mm	-	7 ton alloy swivel	CR#8 eyenut	>5	62 lb 28 kg
10,000 lb 5,000 kg	2 lb 1 kg	20.5 in 521 mm	2.50 in 64.0 mm	3.50 in 89.0 mm	1.81 in 46.0 mm	1.69 in 42.9 mm	-	7 ton alloy swivel	CR# 8 eyenut	>5	62 lb 28 kg
20,000 lb 10,000 kg	5 lb 2 kg	28.5 in 724 mm	4.00 in 101.6 mm	6.25 in 159 mm	2.62 in 66.5 mm	2.41 in 61.2 mm	-	15 ton alloy swivel	CR# 11 eyenut	>7	105 lb 47 kg
30,000 lb 15,000 kg	10 lb 5 kg	30.0 in 762 mm	4.00 in 101.6 mm	6.25 in 159 mm	3.00 in 76.2 mm	3.19 in 81.0 mm	-	22 ton alloy swivel	CR# 11 eyenut	>5	125 lb 55 kg
50,000 lb 25,000 kg	10 lb 5 kg	41.0 in 1041 mm	5.00 in 127 mm	6.00 in 152 mm	3.62 in 92.0 mm	3.63 in 92.0 mm	15.0 in 381 mm	30 ton alloy swivel	CR25ton shackle# 2130	>5	235 lb 106 kg
70,000 lb 35,000 kg	20 lb 10 kg	43.2 in 1097 mm	5.00 in 127 mm	6.00 in 152 mm	4.56 in 116 mm	3.75 in 95.0 mm	15.0 in 381 mm	37 ton alloy swivel	CR40ton alloy shackle# 2140	4.75	270 lb 121 kg
100,000 lb 50,000 kg	20 lb 10 kg	52.1 in 1324 mm	5.75 in 146 mm	6.65 in 169 mm	5.06 in 129 mm	4.25 in 108 mm	16.25 in 413 mm	45 ton alloy swivel	CR55ton alloy shackle# 2140	4.5	420 lb 189 kg
								60 ton alloy swivel	CR55ton alloy shackle# 2140	5	510 lb 231 kg
								75 ton alloy swivel	CR55ton alloy shackle# 2140	5	630 lb 286 kg

CR = Crosby or equivalent.

* These dimensions also apply to 50/70/100000 lb. units with hook and shackle.

** Resolution subject to change for NIST and OIML approved units.

Alternate Hooks
for 100,000 lb

Figure 6-1. MSI-4260 IS Product Dimensions

6.4 Specifications

Accuracy

$\pm(0.1\% + 1d)$. 'd' equals one displayable increment

Resolution

Standard displayed resolution: 2500-3750 d
Resolutions to 10000 d (non LFT units only) are possible
Internal A/D resolution 24 bits

Standard Capacities

lb 500 2000 5000 10000 20000 30000 50000 70000 100000
kg 250 1000 2500 5000 10000 15000 25000 35000 50000

Power

Battery operated, 12V rechargeable sealed lead acid battery pack

Display

5 digit, large 1.2" (30.5 mm) numeric red GaAlAs Light Emitting Diode (LED)

Operating Temperature

-40°F to +122°F (-40°C to +50°C)
LFT range +14°F to +104°F (-10°C to +40°C)
IS range +14°F to +122°F (-10°C to +50°C)

Enclosure

Powder coated anodized cast aluminum

Load Cell

Standard 350 Ω Bridge, MSI Trinocular (>10k lb)

User

Programmable multifunction button for use as
TEST, TOTAL, UNIT, PEAK, NET/GROSS, VIEW TOTAL, LEARN
(for RF Remote Control)

CAL

Wire sealed calibration switch (located on the left side of the front casting)
Initiates full digital calibration procedure

Auto Zero Maintenance

Standard, can be disabled internally

Auto off Mode

Prolongs battery life by turning POWER off after 15, 30, 45 or 60 minutes
(operator determined) of no scale activity

Auto Sleep Mode

Prolongs battery life by dimming LED display after 5, 15, or 30 minutes of
no activity

Units

kg, lb (other units available with custom calibrations)

Filtering

Selectable:

- OFF, Low (LO)
- Medium (HI-1)
- High (HI-2)

Totalization

Standard: Press button or Automatic; TOTAL weight up to 99999 X 1000
kg or lb

Peak

Uses unfiltered faster reading of A/D (>400 readings per second)

Setpoints

Three internal standard setpoints and three ultra bright LEDs on the indi-
cator panel; Contact factory

Service Counter

Two independent 32 bit registers;

- Register 1 updated each time weight exceeds 25% of capacity;
- Register 2 updated each time weight exceeds overload
- When register 1 exceeds 16383 or register 2 exceeds 1023,
display reads LCnt for load cell counter;
Test function shows the two readings in order

Construction

All features are housed in heavy duty, cast aluminum housing consisting of
three sections:

- The front of the scale houses the display, controls and all electronics
- The center section contains the load cell, lifting eye and hook
- The back of the scale features a quick access battery compartment
- The back of the scale features a quick access battery
- Refer to the Conditions of Use in Hazardous Locations document, PN 184530, for conditions of use in hazardous environments regarding construction

Certifications and Approvals



CoC Number:88-098A1
Accuracy ClassIII $L_{n_{max}}$: 5000



USA: FM 16US0156X
Refer to the Conditions of Use in Hazardous Locations
document for Certification and Classification details.



Canada: FM 16CA0092X
Refer to the Conditions of Use in Hazardous Locations
document for Certification and Classification details.



ATEX: FM 16ATEX0038X
Refer to the Conditions of Use in Hazardous Locations
document for Certification and Classification details.



© Rice Lake Weighing Systems Specifications subject to change without notice.
Rice Lake Weighing Systems is an ISO 9001 registered company.

230 W. Coleman St. • Rice Lake, WI 54868 • USA
U.S. 800-472-6703 • Canada/Mexico 800-321-6703 • International 715-234-9171 • Europe +31 (0)26 472 1319