

KPOS 1530 POS Scale



Service Manual

Contents subject to change without notice

Version 01.03

03/2017

Specification	25
Top and Front View	25
Interface Details	25
Calibration switch location.....	25
Faceplate	26
Symbols on LCD screen	26
Key function	26
Operation Menu Structure	25
Normal weighing mode (Calibration Switch is off)	25
Calibration Switch is on	25
CAL Submenu	25
USER Submenu.....	26
Config setting	25
Calibration Switch is on.....	25
Weighing operation:	25
Calibration	25
Serial Communication	27
TYPE-0 and TYPE-1 INTERFACE	25
TYPE-2 INTERFACE	26
TYPE-3 INTERFACE	25
TYPE-4 INTERFACE	26
TYPE-5 INTERFACE	25
TYPE-6 INTERFACE	25
TYPE-7 INTERFACE	26
TYPE-8 INTERFACE	26
Connectors and Jumpers	25
Overview of Connectors or jumpers on PCB	25
Load Cell Connector	25
Adapter.....	25
Serial Input Output Connector	25
USB	26
Calibration switch.....	26
Troubleshooting	26
Error Codes.....	26
Troubleshooting	25
RS-232 cable pinout	26
Interface reference	27
Maitre'D Setup	28
Maitre'D Setup	28
Cabling.....	30
Scale Setup	30
Pc America Setup	32
Scale Setup	32
Setup CRE/RPE	0

Specification

Top and Front View

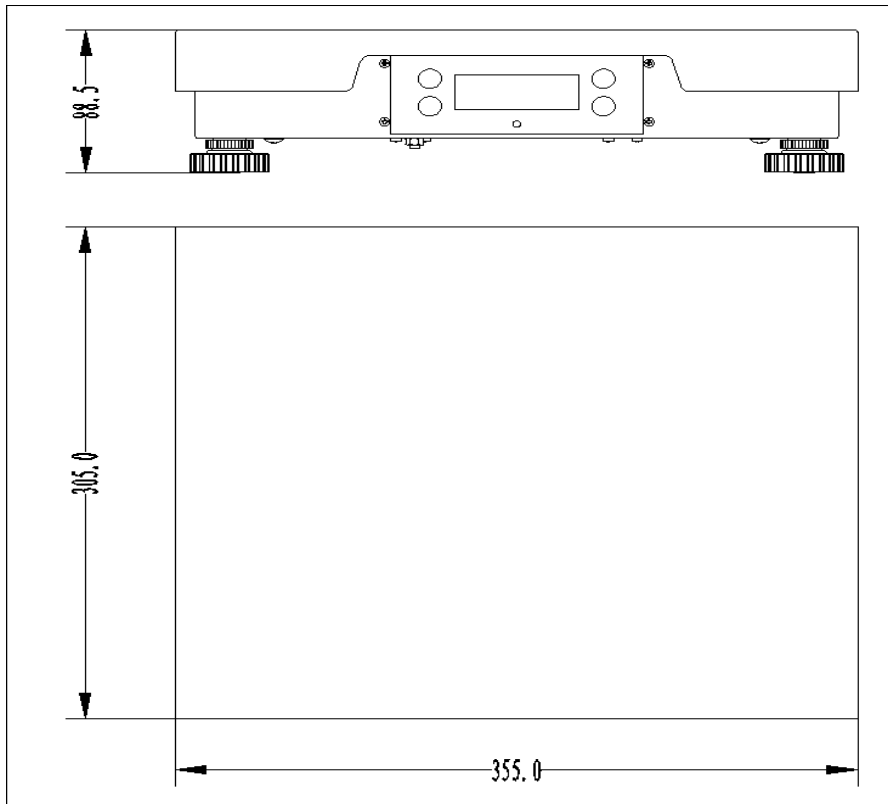

Interface Details

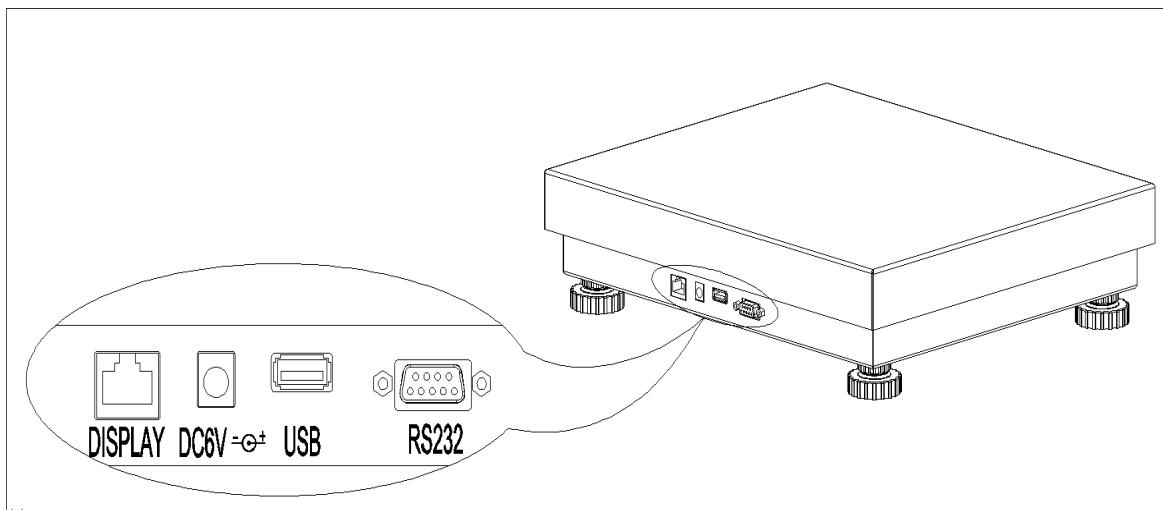

Calibration switch location

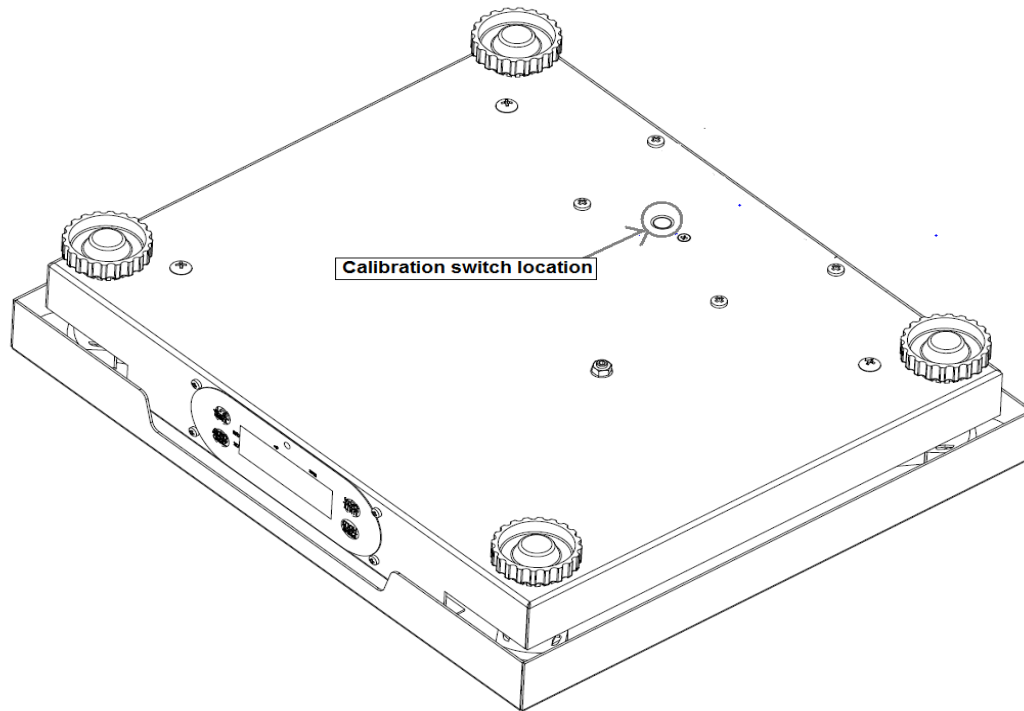

Power Supply:

- AC Adapter: 7-9V_{DC}, ≥500mA, central positive:
- USB power supply if USB interface is installed

Display:

- 5 1/2-digit, 7-segment, 0.58" (15mm) LCDs

Keypad:

- 3 push buttons

Environment:

- Working temperature: -10°C to 40°C
- Storage temperature: -20°C to 70°C
- Humidity: 10 to 90% RH without condensation

Load cell Excitation:

- 1.6.1 Voltage: 5Vdc
- 1.6.2 Max. Current: 20mA

Communication:

- Optional Serial port: USB (Virtual RS232), RS232
- Baud Rate: Selectable: 1200-2400-4800-9600-19200-38400 bps
- Data Output Format: 8N1, 7O1, 7E1
- Protocol: programmable

Faceplate

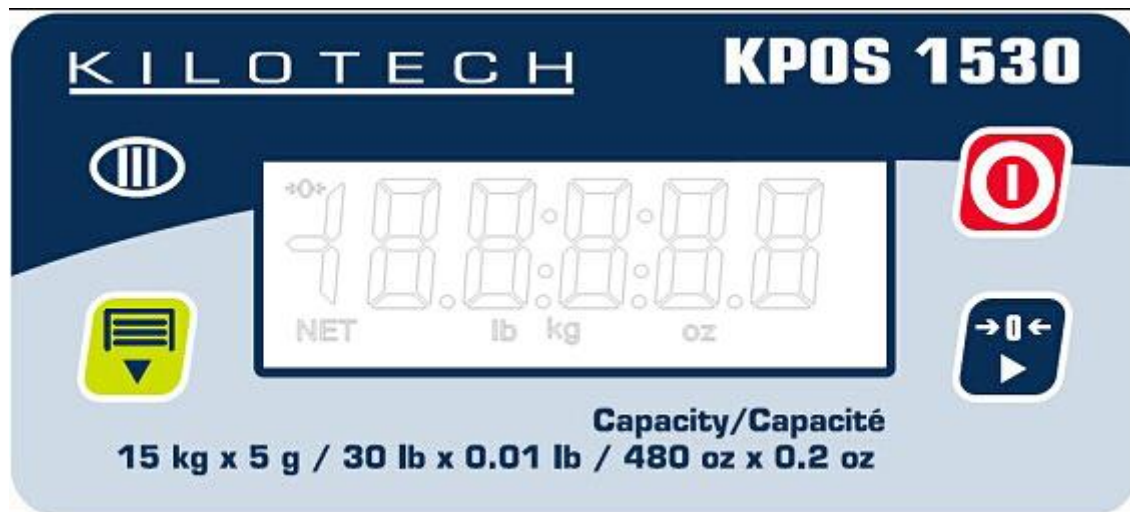

Symbols on LCD screen

- 2.1  turn on when scale is at zero point and the gross weight is 0
- 2.2 **lb** turn on when measure unit is lb
- 2.3 **oz** turn on when measure unit is oz
- 2.4 **kg** turn on when measure unit is kg
- 2.5 **NET** turn on when net weight is displaying, and the tare weight is not 0; turn off when gross weight is displaying

Key function

Mode			
Normal weighing mode	Turn scale on/off	Zero	Enter Backlight setting
Cal mode	Turn scale on/off	Confirm choice	Enter menu or move to next chapter

Operation Menu Structure

Normal weighing mode (Calibration Switch is off)

Under normal weighing mode, when the seal switch is off, use MENU key to toggle between AL.ON, WT.ON, or AL.OFF, which meaning Backlight On, Backlight auto on when key operation or weight changing, and auto off after 30s elapsed, or Backlight Off. Press Zero to confirm the setting, and the scale will be back to normal weighing mode.

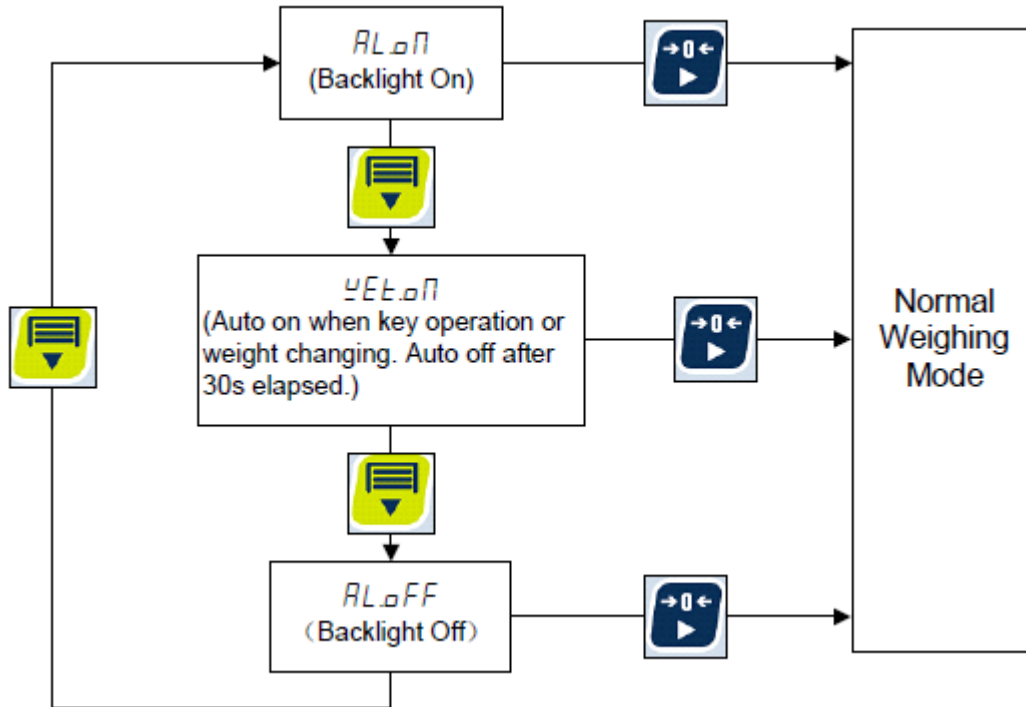

Calibration Switch is on

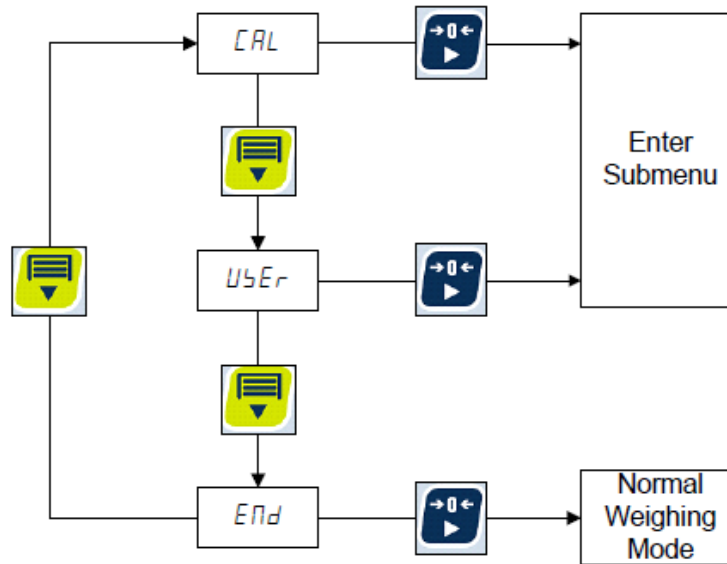

Under normal weighing mode, when the seal switch is on, press MENU key, "CAL" will be shown in display window, press MENU key to shift between "USER", "END" or "CAL", and press ZERO key to confirm to enter into the menu.



CAL Submenu

CAL			
Submenu1	Submenu2	Option	Remark
WET.UT	KG		Setting weight unit.
	LB		
	OZ		
CAL.UT	KG		Setting calibration unit.
	LB		
LINE	CAL.P0		Linear calibration point 0: do zero point calibration, this point can't be omitted.
	CAL.P1		Linear calibration point 1: do first weight point calibration, this point can't be omitted and standard weight must be over 10%FS.
	END.Y	YES	End calibration?
	END N	NO	YES: back to submenu1; NO: go to do next point calibration
	CAL.P2		Linear calibration poin2: do second weigh point calibration, standard weight must be over 10% FS and be larger than it in CAL.P1, After calibrate the point, it will back to the submenu1.
END			Press  to confirm to end, and the scale will back to CAL MENU.

USER Submenu

USER				
Submenu1	Submenu2	Option	Default	Remark
COM	CMD.SR	NONE	RS232	Source of the executed command selection: NONE: no any command will be executed ; USB: command from COM1 will be executed; RS232: command from COM2 will be executed; USB.RS: command from USB or RS232 will be executed
		USB		
		RS232		
		USB.RS		
	INTFC	NONE	TYPE1	Interface with USB/RS232 (please refer to 7.Details about Serial Communication.)
		TYPE0-8		
	BUD.RT	1200	9600	Selection of USB/RS232 baud rate
		2400		
		4800		
		9600		
		19200		
		38400		
	BT.FMT	8N1	8N1	Selection of USB/RS232 byte format.
7O1				
7E1				
END				Press  to confirm to end, and the scale will back to submenu1.
PHD.RG	0~8		0	Remote TARE sensitivity set: 0=remote TARE key is disable 1~8=sensitivity level is set to 1~8.
END				Press  to confirm to end, and the scale will back to USER menu.

Config setting

Calibration Switch is on

Under normal weighing mode, when the seal switch is on, long press MENU + ON/OFF key, “**CONFIG**” will be shown in display window, press MENU key to shift between “CAL”, “USER”, “MISC”, “TEST”, “END” or “CAL”, and press ZERO key to confirm to enter into the menu.

Sub-Menu1		Option	Default	Remark
RESET		NO	NO	reset to default setting
		YES		
CAP		15KG	15KG	Select capacity: 15kg/30lb, 30kg/70lb, 60kg/150lb
		30KG		
		60KG		
AZSM		0-100	8	Zero tracking window: 0=0d, no tracking; 1-100= $\pm(0.2+0.05*(1-100))d/s$
FLTER	FT1.TH	0-255	40	Enter digital filter1 threshold: 0=no filter1; 1-254=filter1 be used only when vibration in $\pm 0.25d*(1-254)$; 255= filter1 be always used
	FLT1.S T	1-64	8	Digital filter1 intensity: 1-64=weak to strong
	FT2.TH	0-255	8	Enter digital filter2 threshold: 0=no filter2; 1-254=filter2 be used only when vibration in $\pm 0.25d*(1-254)$; 255= filter2 be always used
	FT2.ST	0-255	240	Digital filter2 intensity: 0-255=weak to strong
	END			Press to confirm to end, and the scale will back to submenu1.
10.DSP		NO	NO	Display weight at 10 times division number under primary unit
		YES		
END				Press to confirm to end, and the scale will back to CONFIG.

Weighing operation:

Power on scale: when scale is off, press **ON/OFF** key to turn on;

Power off scale: when scale is on, press and hold **ON/OFF** key to turn off the scale.

ZERO: When the weight is stable and within the zero range (2%FS) , press **ZERO** key to set new zero point.

How to change weight unit

With the calibration switch on, turn on the scale and enter into normal weighing mode.

- Press **MENU** key, and **CAL** will be displayed.
- Press **ZERO** key to confirm to enter this mode. A calibration counter will be displayed and then **WET.UT**.
- Press **ZERO** key to confirm.
- Use **MENU** key to toggle between kg, lb, or oz.
- Press **ZERO** key to confirm. The scale will show **WET.UT**
- Use **MENU** key to scroll to **END**.
- Press **ZERO** key to confirm.
- Scale will restart
- Close calibration switch

The scale will return back to normal weighing mode.

Calibration

Note: Please prepare a standard weight (more than 10% of FS weight) prior to starting calibration.

With the calibration switch on, turn on the scale and enter into normal weighing mode

- Press **MENU** key, and **CAL** will be displayed
- Press **ZERO** key to confirm to enter this mode. A calibration counter will be displayed and then **WET.UT**
- Press **MENU** key to select **CAL.UT**
- Press **ZERO** key to confirm
- Press **MENU** to toggle between kg and lb
- Press zero to confirm. The scale will show **CAL.UT**
- Press **MENU** to select **LINE**
- Press **ZERO** to confirm
- Scale will show **CAL.P0**. Remove all weight on scale
- Press **ZERO** to confirm to calibrate the zero point; the zero weight will flash and show **CAL.P1**
- Put the weight (more than 10%FS weight) onto scale
- Set the corresponding weight value on the display by pressing **MENU** key to increase and **ZERO** key to change the position of the cursor (active number will flash)
- Once the correct value has been set, press **ZERO** key to confirm
- Scale will show **END.Y** and **Y** is flashing
- Press **ZERO** to confirm
- Scale will show **LINE**
- Press **MENU** key to select **END**
- Press **ZERO** to confirm
- Scale will reboot
- Close calibration switch

If scale shows **CAL.Er**” Review the setup parameters and try to recalibrate the scale again

Config menu

In normal weighing mode, when the seal switch on, long press MENU + ON/OFF key, “**CONFG**” will be shown in display window, press MENU key to shift between “**CAL**”, “**USER**”, “**MISC**”, “**TEST**”, “**END**” or “**CAL**”, and press ZERO key to confirm to enter into the menu.

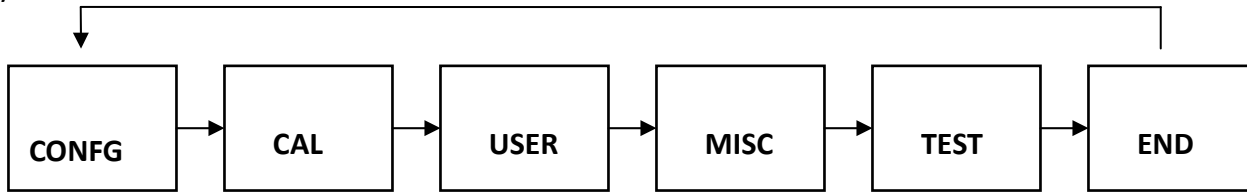

CONFG Submenu:

Sub- Menu1		Option	Default	Remark
RESET		NO	NO	reset to default setting
		YES		
CAP		15KG	15KG	Select capacity: 15kg/30lb, 30kg/70lb, 60kg/150lb
		30KG		
		60KG		
AZSM		0-100	8	Zero tracking window: 0=0d, no tracking; 1-100= $\pm(0.2+0.05*(1-100))d/s$
FLTER	FT1.TH	0-255	40	Enter digital filter1 threshold: 0=no filter1; 1-254=filter1 be used only when vibration in $\pm 0.25d*(1-254)$; 255= filter1 be always used
	FLT1.S T	1-64	8	Digital filter1 intensity: 1-64=weak to strong
	FT2.TH	0-255	8	Enter digital filter2 threshold: 0=no filter2; 1-254=filter2 be used only when vibration in $\pm 0.25d*(1-254)$; 255= filter2 be always used
	FT2.ST	0-255	240	Digital filter2 intensity: 0-255=weak to strong
	END			Press  to confirm to end, and the scale will back to submenu1.
10.DSP		NO	NO	Display weight at 10 times division number under primary unit

Serial Communication

- Serial port: Wires come from RS232 connector, and **TXD1**, **RXD1** and **GND** are used.
- USB port: Wires come from USB connector, and **TXD0**, **RXD0** and **GND** are used.
- The baud rate and byte format is set by **USER-COM-BAUD.RT** and **USER-COM-BYT.FMT**. Responses to serial commands will be immediate, or within one weight measure cycle of the scale. One second should be adequate for use as a time-out value by remote (controlling) device.

TYPE-0 and TYPE-1 INTERFACE

▶ Most POS Systems, ECRs and some TEC POS Systems.

1) PROTOCOL

<ENQ> -----> Initiate communication
 <DC2> -----> Request of weight data
 <ACK> <----- : Acknowledge the request of weight data

----- Inquiry

<----- <STX> : Start Transmission
 <----- <ID> : Scale type identifier
 <----- <W5> : Weight data
 <----- <W4> : Weight data
 <----- <W3> : Weight data
 <----- <W2> : Weight data
 <----- <W1> : Weight data
 <----- <BCC> :Block Check
 <----- <ETX> : End Transmission

Scale Type Identifier

2kg -> G (47H)	-
5kg -> H (48H)	5lb -> K (4BH)
6kg -> C (43H)	-
10kg -> I (49H)	10lb -> L (4CH)
15kg -> A (41H)	15lb -> F (46H)
20kg -> J (4AH)	20lb -> M (4DH)
25kg -> P (50H)	-
30kg -> B (42H)	30lb -> D (44H)
-	50lb -> N (4EH)
60kg -> O (4FH)	60lb -> E(45H)
-	120lb-> Q(51H)

Block Check Character

: <BCC> has all data bytes except <STX> and <ETX> through exclusive OR(XOR).

* Parity Bit : Even

- Data Byte : <STX><ID><W5><W4><W3><W2><W1><BCC><ETX>

TYPE-2 INTERFACE

: Discontinual RS-232C Interface ▶

▶ SHARP ER-AXXX, ER-A450T, New SANYO ECRs using RS-232, TOLEDO 3213 etc.

1) PROTOCOL

<W> ----->

←----- Response

<STX> 0XXXX <CR> : lb weighing mode or <STX>

XXXXX <CR> : kg weighing mode

Error message : <STX>?<status byte><CR>

== STATUS BYTE ==

PARITY	ALWAYS==1		ZERO		MINUS	OVERLOA	MOTION
Bit 7	Bit 6	Bit 5	Bit 4	Bit3	Bit 2	Bit 1	Bit 0

cf) W : 57H (ASCII code) STX : 02H

(ASCII code)

CR : 0DH (ASCII code)

Ex) Weight : 12.34 lb

ECR SCALE

W<57H> ----->

←----- <02H><30H><31H><32H><33H><34H><0DH> : ASCII code

STX 0 1 2 3 4 CR

TYPE-3 INTERFACE

: Continual RS-232C Interface

▶ SHARP ER-AXXX, New SANYO ECRs using RS-232, TOLEDO 3213 etc

1) PROTOCOL

<W> ----->

←----- Response

<STX> 0XXXX <CR> : lb weighing mode

<STX> XXXXX <CR> : kg weighing mode

Error message : <STX>?<status byte><CR>

<CR> -----> Stop transmitting data

Ex) Weight : 12.34 lb

ECR SCALE

W<57H> ----->

←-----<02H><30H><31H><32H><33H><34H><0DH> : ASCII code

STX 0 1 2 3 4 CR

←-----<02H><30H><30H><30H><30H><30H><0DH> : ASCII code

STX 0 0 0 0 0 CR

←-----<02H><3FH><44H><0DH>

STX ? MINUS CR

2) TRANSMISSION PROCEDURE

(1) POS SCALE sends data to External Device whenever weight is changed after receiving <W> signal from the External Device.

(2) POS SCALE stops sending data when receives <CR> signal from the External Device.

ECR SCALE

<W> ----->

←----- DATA (If weight is changed)

←----- DATA (If weight is changed)

<CR> -----> Stop transmitting data

TYPE-4 INTERFACE

▶ NCI ECR(NCR2170), SAMSUNG ER-5100,ER-5115, CRS .etc

1) PROTOCOL

<W> ----->

<CR> ----->

..... Inquiry

←----- <LF> XX.XXX LB <CR>

←----- <LF> S b1b2 <CR><ETX>

..... lb CASE

←----- <LF> XX.XXX KG <CR>

←----- <LF> S b1b2 <CR><ETX>

- (A) XX.XXX = Weight value
- (B) LB = The Characters L and B
- (C) KG = The Characters K and G
- (D) S = The Character S
- (E) b1b2 = Two status Characters

i> Status Bytes

Bit7	Parity Bit	Parity Bit
Bit6	0	0
Bit5	1 (Always 1)	1 (Always 1)
Bit4	1 (Always 1)	1 (Always 1)
Bit3	0	0
Bit2	0	0
Bit1	1 = Scale at Zero 0 = Not at Zero	1 = Over Capacity 0 = Not Over Capacity
Bit0	1 = Scale in Motion 0 = Stable	1 = Under Capacity 0 = Not Under Capacity

ii> Simplified Status Codes

B1	B2	STATUS Definition
ASCII Character (ASCII Code)	ASCII Character (ASCII Code)	
0 (30H)	0 (30H)	OK
1 (31H)	0 (30H)	Motion
2 (32H)	0 (30H)	Scale at Zero
0 (30H)	1 (31H)	Under capacity
0 (30H)	2 (32H)	Over capacity

TYPE-5 INTERFACE

▶ NCI GENERAL, SAMSUNG ER-5115, ER-5100 and Most P.O.S Software

1) PROTOCOL

<W> ----->

<CR> ----->

..... Inquiry

←----- <LF> XX.XXX LB <CR>

←----- <LF> b1b2 <CR><ETX>

..... lb CASE

←----- <LF> XX.XXX KG <CR>

←----- <LF> b1b2 <CR><ETX>

XX.XXX = Weight value (Decimal point: variable)

LB = The Characters L and B

KG = The Characters K and G

OZ = The Characters O and Z

b1b2 = Two status Characters

i> Status Bytes

Bit7	Parity Bit	Parity Bit
Bit6		0
Bit5	1 (Always 1)	1 (Always 1)
Bit4	1 (Always 1)	1 (Always 1)
Bit3		0
Bit2		0
Bit1	1 = Scale at Zero 0 = Not at Zero	1 = Over Capacity 0 = Not Over Capacity
Bit0	1 = Scale in Motion 0 = Stable	1 = Under Capacity 0 = Not Under Capacity

ii> Simplified Status Codes

B1	B2	STATUS Definiti
ASCII Characte	ASCII Characte	
0	0	OK
1	0	Motio
2	0	Scale at Zero
0	1	Under capacity
0	2	Over capacity

TYPE-6 INTERFACE

- ▶ 8 Data bit
- ▶ None parity
- ▶ 1 stop bit
- ▶ SAMSUNG ECR (ER-670)

1) PROTOCOL

EXTERNAL DEVICE

POS SCALE

- <ENQ> -----> Initiate communication
- < <ACK>: Acknowledge the request of weight data
- <DC1> or <DC2> -----> DC1 : For Weight Data
- < DC2 : For All Data
- < Send Data Block

- **The Data Train**

“DC1”

SOH	STX	STA	SIGN	W5	W4	W3	W2	W1	W0	UN1	UN0	BCC	ETX	EOT
Command		DATA BLOCK										Command		

- STA : A WEIGHING STATUS OF THE SCALE
 - SCALE IS STABLE -> "S",
 - NOT STABLE -> "U"
- SIGN : SIGN OF THE WEIGHT DATA
 - ZERO AND POSITIVE WEIGHT -> " "
 - NEGATIVE WEIGHT -> "-"
 - OVER LOAD -> "F"
- W5 THROUGH W0 -> WEIGHT DATA
 BUT ALL "F" WHEN THE SCALE IS PUT ON OVER LOAD.
- UN1 THROUGH UN0 -> UNIT OF WEIGHT (Kg OR Lb)
- BCC : BLOCK CHECK CHARACTER

TYPE-7 INTERFACE

 Continuous output

Continuous output

<STX> XXXXX.XX^oz<ETX> or

<STX> XXXXXXXX^oz<ETX>

<STX> XXXX.XXX^kg<ETX> or

<STX> XXXXX.XX^kg<ETX>

<STX> XXXX.XXX^lb<ETX> or

<STX> XXXXX.XX^lb<ETX>

TYPE-8 INTERFACE

 Output when stable

Output when stable

When the scale shows a positive weight and stable signal it will broadcast **once** the following data train.

<STX> XXXXX.XX^oz<ETX> or

<STX> XXXXXXXX^oz<ETX>

<STX> XXXX.XXX^kg<ETX> or

<STX> XXXXX.XX^kg<ETX>

<STX> XXXX.XXX^lb<ETX> or

<STX> XXXXX.XX^lb<ETX>

Connectors and Jumpers

Overview of Connectors or jumpers on PCB

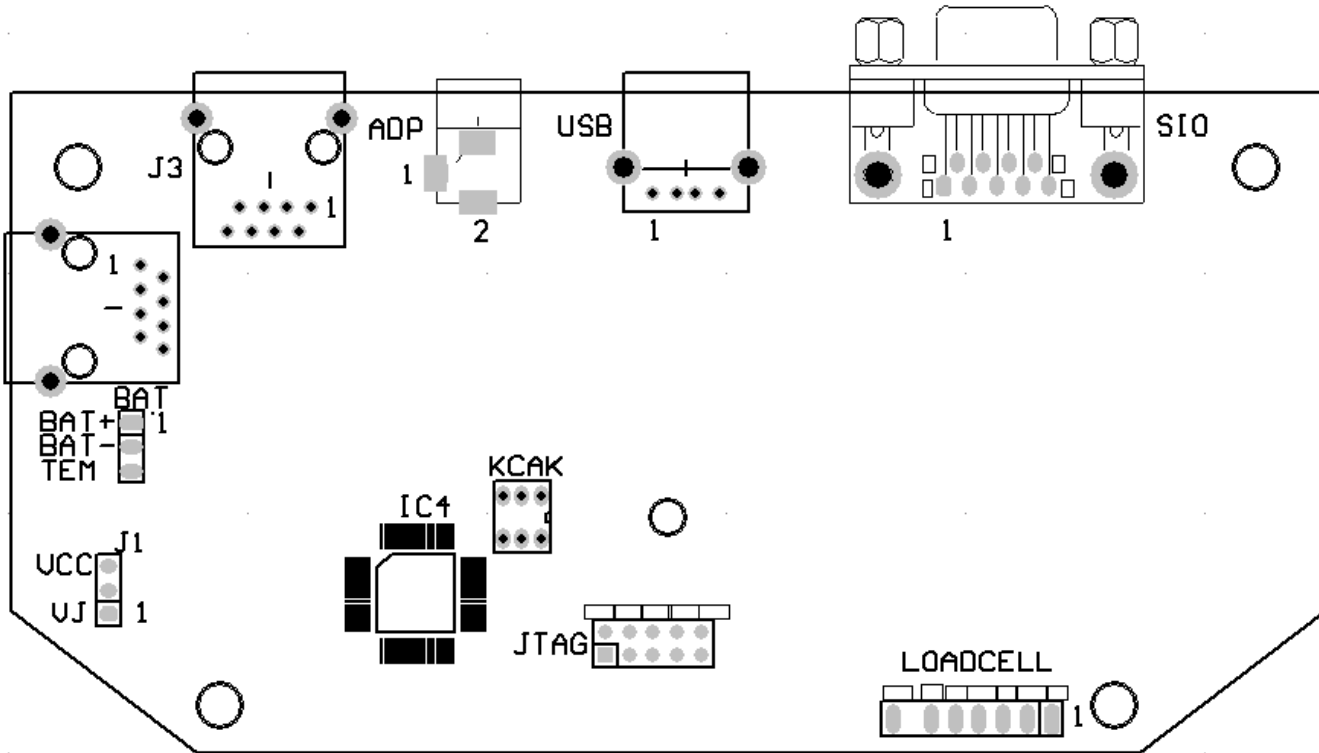

Load Cell Connector

PIN	DEFINITION	IN/OUT/POWER	ELECTRICAL LEVEL
1	Excitation +	Power output	5±0.3 Vdc (≤0.12A)
2	Sense +	Power input	5±0.3 Vdc
3	Excitation-	Power ground	0Vdc
4	Sense -	Power input	≤0.5 Vdc
5	Signal +	Signal Input	2.5±0.3 Vdc
6	Signal -	Signal Input	2.5±0.3 Vdc
7	Shield	-	-

Adapter

PIN #	DEFINITION	IN/OUT/POW	ELECTRICAL LEVEL
1	Adapter input voltage - (GND)	Power ground	0Vdc
2	Adapter input voltage +	Power input	6.5Vdc(6-9Vdc,≥0.5A)

Serial Input Output Connector

PIN #	DEFINITION	IN/OUT/POWER	ELECTRICAL LEVEL
2	RS232 Transmit on UART0	Output	-12 to +12Vdc
3	RS232 Receive on UART0	Input	-12 to +12Vdc
5	GND	Power ground	0Vdc

USB

PIN #	DEFINITION	IN/OUT/POWER	ELECTRICAL LEVEL
1	GND of VDD	Power ground	0Vdc
2	USB D+		0-5Vdc
3	USB D-		0-5Vdc
4	USB Power	Power input	5±0.25 Vdc

Calibration switch

CONNECTED PINS	FUNCTION
push	Calibration Enabled
No push	Calibration Disabled

- NET Socket J2 and J3: used for display
- JTAG used by Manufacture

Troubleshooting

Error Codes

0-----	Zero point is over the setting range
0-----	Zero point is below the setting range
Ad-----	Signal to ADC is over max. range
Ad-----	Signal to ADC is below min. range
-----	Weight is over upper limitation, or display data is over limitation
-----	Weight is below lower limitation
EEPE1	CONFIG or CAL parameters are not correctly set
EEPE2	USER parameter is not correctly set
Lo.bAt	Battery voltage is lower than setting.
CAP.- - -	Next displaying content is Capacity
CAP.ER	Parameters about Capacity is not correct
CAL.Px	Calibration on point(x)
CA.OFF	Calibration Seal Switch is on OFF position
CAL.ON	Calibration Seal Switch is on ON position
CAL.Er	Calibration error, maybe input data or loaded weight is incorrect, unstable, un-linear
CA.End	Calibration is end
OFF	Power OFF the indicator

Troubleshooting

SYMPTOM	PROBABLE CAUSE	REMEDY
Ad -----	Load cell wires to indicator are incorrectly connected, or shorted, or opened; or ADC, load cell are damaged	Make sure wires are ok and correctly connected. Replace load cell or ADC chip, Service required.
Ad -----		
0 -----	Weight reading exceeds Power On Zero limit.	Make sure scale platform is empty. Perform zero calibration.
0 -----	Weight reading below Power On Zero limit.	Install platform on scale. Perform zero calibration.
-----	Weight reading exceeds Overload limit, or The weight value cannot be displayed in the current unit of measure because it exceeds 6 digits..	Reduce load on scale until weight value can be displayed. Use a more appropriate unit of measure. Re-set some parameters of COFIG or UAER.
-----	Weight reading below Under load limit.	Install platform on scale. Perform zero calibration
EEPE1	CONFIG or CAL parameters are not correctly set	Re-set items in CONFG, do calibration
EEPE2	USER parameter is not correctly set	Re-set items in USER
CAPER	Capacity parameters are not correct	Set PRIM.N/PRIM.d/ SECD.N to correct number, make sure capacity not more than 6 digit
CAL.Er	Calibration error, maybe input data or loaded weight is too small, too big, unstable, un-linear	Input correct data, load correct weight onto platform, Service required
Not turn on.	Power cord not plugged in or properly connected. Power outlet not supplying electricity. Battery discharged. Other failure.	Check power cord connections. Make sure power cord is plugged into the power outlet. Check power source. Replace batteries. Service required.
Cannot zero the display or will not zero when turned on.	Load on scale exceeds allowable limits. Load on scale is not stable. Load cell damage.	Remove load on scale. Wait for load to become stable. Service required.
Battery symbol is empty or Lo.bAt is shown	Batteries are discharged.	Charge batteries

RS-232 cable pinout

SCALE	CABLE(9 pins)	HOST
DB9(Female)		DB9(Male)
PIN2 TXD	-----2-----3-----	PIN2 RXD
PIN3 RXD	-----3-----2-----	PIN3 TXD
PIN5 GND	-----5-----5-----	PIN5 GND

Interface reference

Cash register Description	Type	Baud rate	Parity	Pinout
Sharp	2	9600	7E1	2---2
				3---3
				5---5
Sam4S	4	9600	7E1	2--3
				3--2
				5--5
Samsung SPS 520	4	9600	7E1	2--3
				3--2
				5--5
Sharp UP-820N	2	9600	7E1	2--3
				3--2
				5--5
TEC 1595	1	2400	7E1	2---3
				3---2
				5---5
Uniwell DX 795	2	9600	7E1	2--3
				3--2
				5--5
PC America	4	9600	7E1	
Maitre'D	2	9600	7E1	2---2
				3---3
				5---5
				4 --
				6 -- -- Jumped together
				8 --
Casio TE 2200 and TE 2400	4	9600	7E1	2---2
				3---3
				5---5
				Female side 4 --6 Jumped together
				7 --8 Jumped together

Maitre'D Setup

(Maitre'D Millennium, and later versions of Maitre'D)

Maitre'D Setup

System Configuration / View / Options / Devices

Scale Type:

Weigh-Tronix 6710 (lbs)

Note: Other than the scale's weight limit, the interface is also limited to a maximum price of 99.99

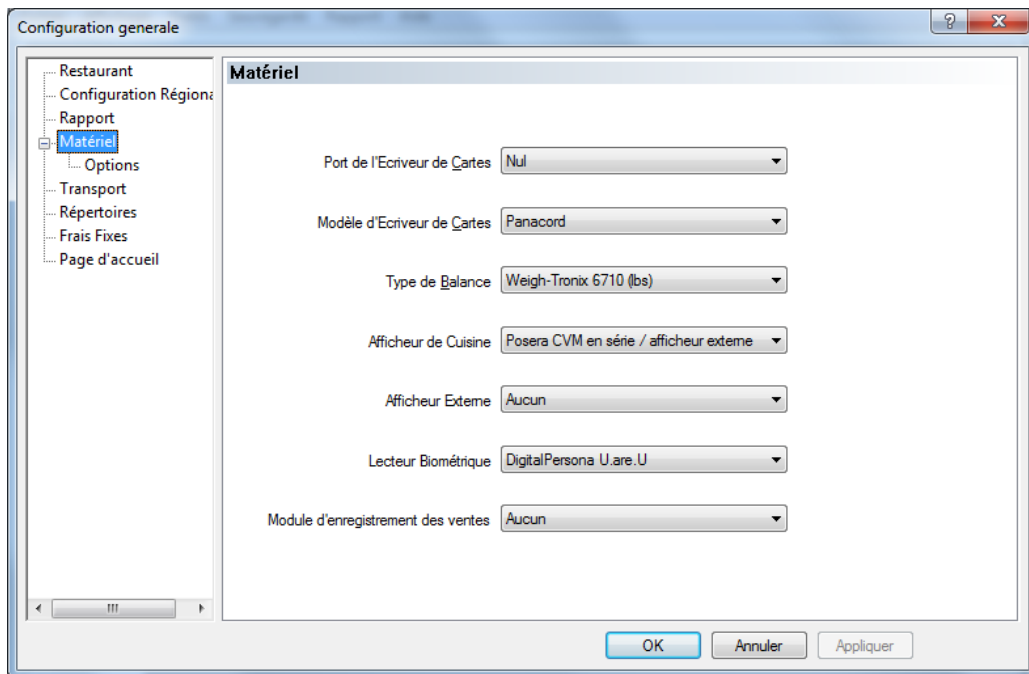

P.O.S. Control / Workstations / Options / Workstation # / Peripherals / Scale

- **Type:** Serial
- **Port:** #
- **Driver:** Generic

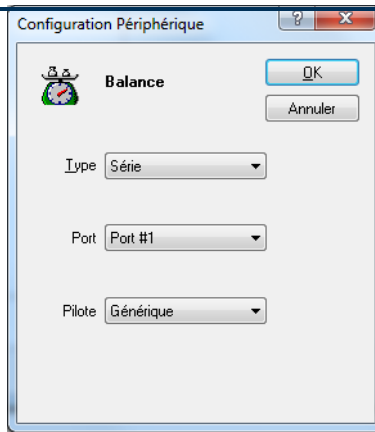

P.O.S. Control / Revenue center / Items Setup / Function

Function: Scale

Division: Weight

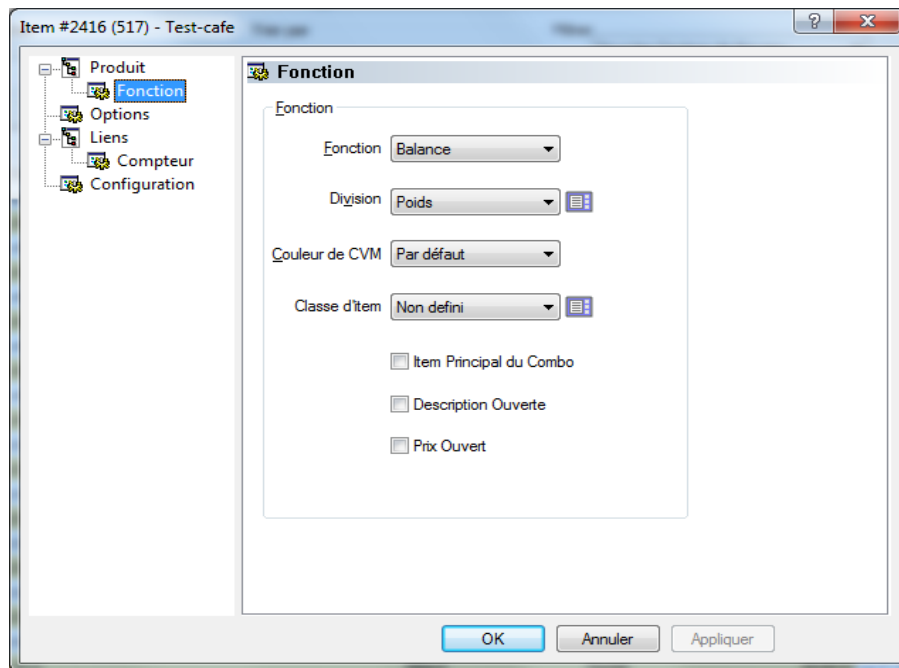

P.O.S. Control / Revenue center / Items Setup / Links

If necessary, enter a weight, in thousandth of pounds, in the Tare field.

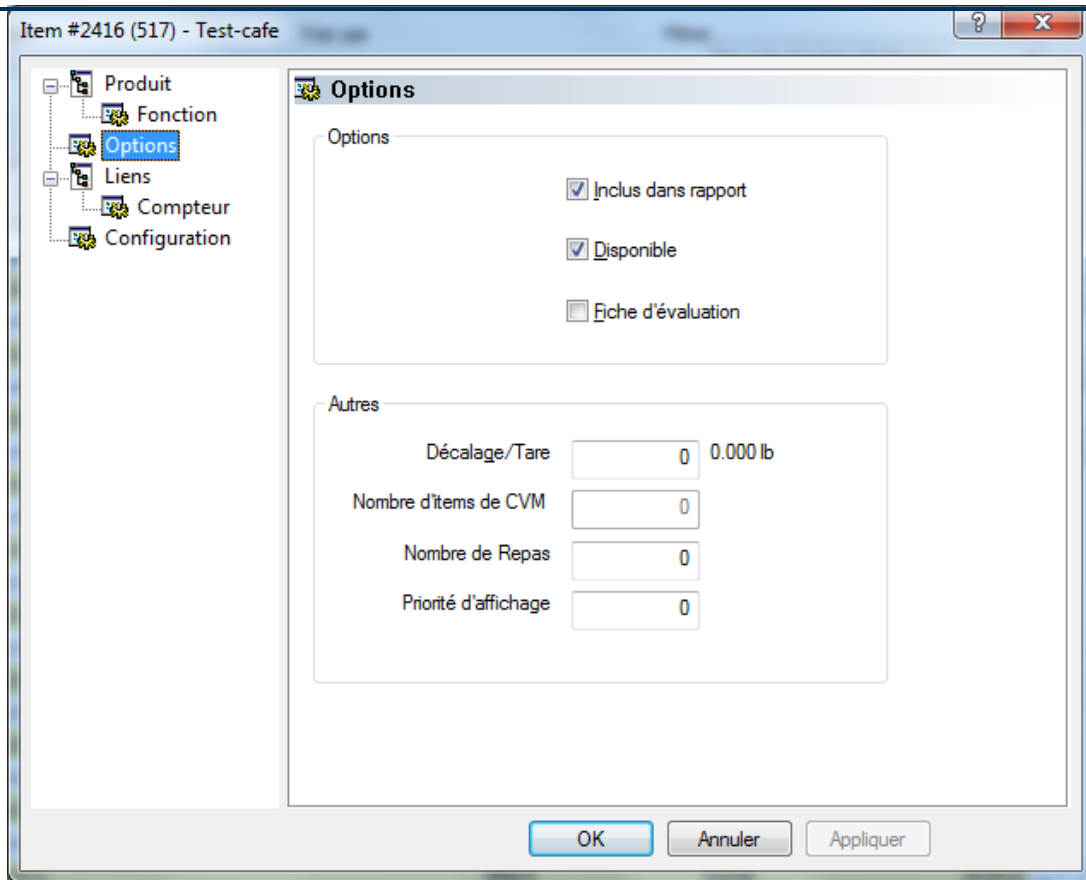

Cabling

From	To
DB-9 Female	DB-9 Male

Pin 2	----->	Pin 2
Pin 3	----->	Pin 3
Pin 5	----->	Pin 5
Shell	----->	Shell
Pin 4	--	
Pin 6	-- --	Jumped together
Pin 8	--	

Scale Setup

- Set **CAL** switch into calibration mode
- Turn on scale
- Press menu key to enter call mode screen will show **CAL**
- Press menu key screen will show **USER**
- Press zero key Screen will show **COM**
- Press zero key screen will show **CMD.SR**
- Press zero key
- Press menu key to scroll. Select **RS232**

- Press zero key to confirm screen will show **CMD.SR**
- Press menu key to confirm and go to next step
- Screen will show **INTFC** press zero to confirm
- Press menu key to scroll. Select **TYPE 2** and press zero key to confirm
- Press menu key to confirm and go to next step
- Screen will show **BUD.RT** press zero to confirm
- Press menu key to scroll. Select **9600** and press zero key to confirm
- Screen will show **BUD.RT** press zero to confirm
- Press menu key to go to next step
- Screen will show **BT.FMT** Press zero to select
- Press menu key to scroll. Select **7E1** and press zero key to confirm
- Press menu key to scroll. Select **END** and press zero key to confirm
- Press menu key to scroll. Select **END** and press zero key to confirm
- Press menu key to scroll. Select **END** and press zero key to confirm
- Set **CAL** switch into normal mode

Pc America Setup

Scale Setup

- Set **CAL** switch into calibration mode
- Turn on scale
- Press menu key to enter call mode screen will show **CAL**
- Press menu key screen will show **USER**
- Press zero key Screen will show **COM**
- Press zero key screen will show **CMD.SR**
- Press zero key
- Press menu key to scroll. Select **RS232**
- Press zero key to confirm screen will show **CMD.SR**
- Press menu key to confirm and go to next step
- Screen will show **INTFC** press zero to confirm
- Press menu key to scroll. Select **TYPE 4** and press zero key to confirm
- Press menu key to confirm and go to next step
- Screen will show **BUD.RT** press zero to confirm
- Press menu key to scroll. Select **9600** and press zero key to confirm
- Screen will show **BUD.RT** press zero to confirm
- Press menu key to go to next step
- Screen will show **BT.FMT** Press zero to select
- Press menu key to scroll. Select **7E1** and press zero key to confirm
- Press menu key to scroll. Select **END** and press zero key to confirm
- Press menu key to scroll. Select **END** and press zero key to confirm
- Press menu key to scroll. Select **END** and press zero key to confirm
- Set **CAL** switch into normal mode

Setup CRE/RPE

Once the KPOS 1530 has been setup and connected to the computer, and powered on you can configure it in CRE/RPE.

- To configure the scale in CRE/RPE
- Select Setup and then Setup Screen

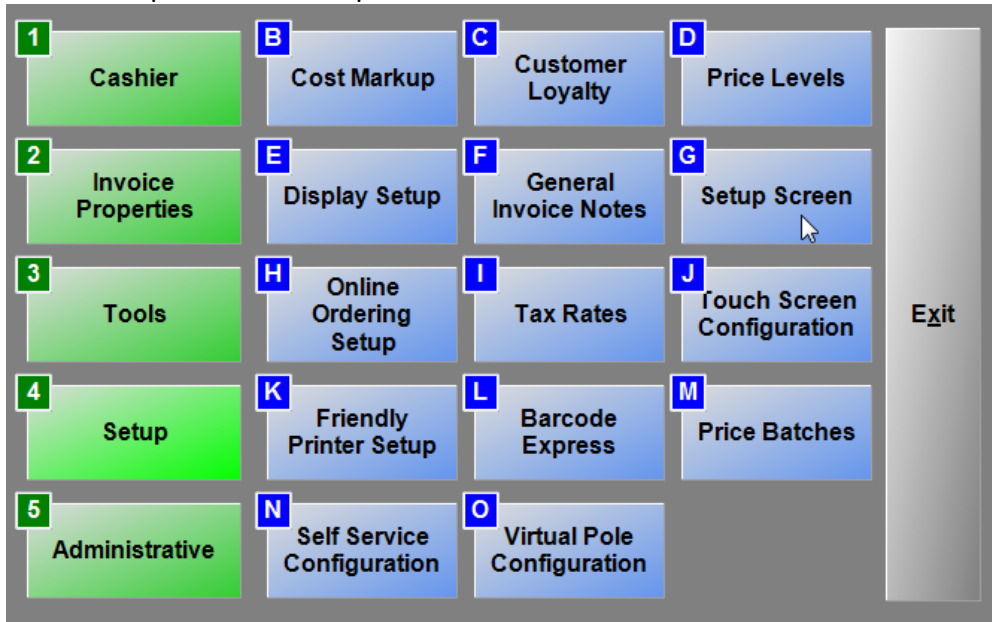

Under the Hardware tab, use the Weight Scale Type as Weightronics NCI-6720 then selecting the appropriately matching COM port.

