

OCSM Series

FEATURES

- Fast resolution switching
- 30mm 5 digits LED display
- Rotatable hook
- Idle mode to maximize the battery life
- HOLD function
- Tare In / Tare Out
- Unit switch: kg / lb
- Auto overload alarm at 100%F.S. +9e
- Auto power-off function



OPTION

- Wireless Scoreboard
- LCD display version, model OCSM2

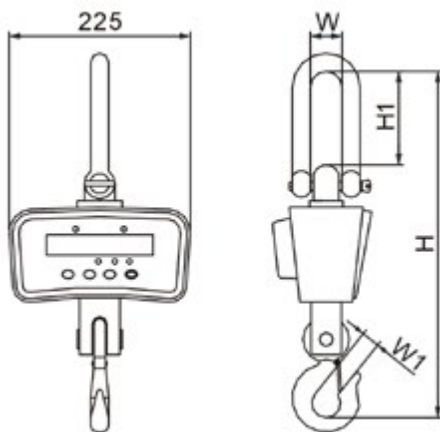

Model	OCSM1
Type	Light
Accuracy Class	OIML III
Enclosure	Die-casting aluminum
Display	30mm LED
Capacity Available	200 / 400 / 600 / 1000 / 2000 lb
Battery Life	80 Hours
High Quality Load Receptor	Alloy Steel
Shackle	Stainless Steel
Hook	Rotatable
High Capacity Rechargeable Battery	Yes 6V/5Ah
Infrared Remote Control	Yes

Rated Capacity	Division	H	H1	W	W1	N.W.	G.W.
200lb	0.1 lb	350mm / 13.78"	80mm / 3.15"	20mm / 0.79"	24mm / 0.94"	4.1kg / 9.0 lb	5.2kg / 11.5 lb
400lb	0.2 lb	350mm / 13.78"	80mm / 3.15"	20mm / 0.79"	24mm / 0.94"	4.1kg / 9.0 lb	5.2kg / 11.5 lb
600lb	0.2 lb	350mm / 13.78"	80mm / 3.15"	20mm / 0.79"	24mm / 0.94"	4.1kg / 9.0 lb	5.2kg / 11.5 lb
1Klb	0.5 lb	370mm / 14.57"	85mm / 3.35"	25mm / 0.98"	36mm / 1.42"	4.3kg / 9.5 lb	5.6kg / 12.3 lb
2Klb	1 lb	370mm / 14.57"	85mm / 3.35"	25mm / 0.98"	36mm / 1.42"	4.3kg / 9.5 lb	5.6kg / 12.3 lb

*Dimensions and specifications are subject to change without notice.