

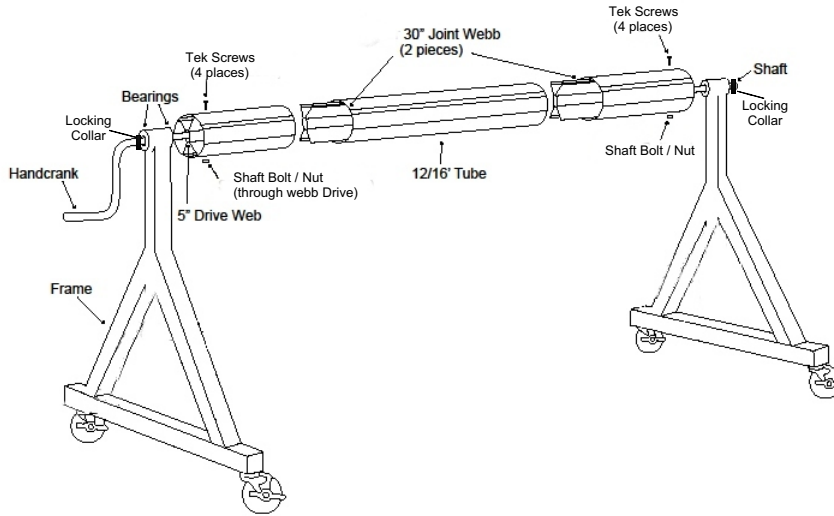

COMMERCIAL REEL SYSTEMS

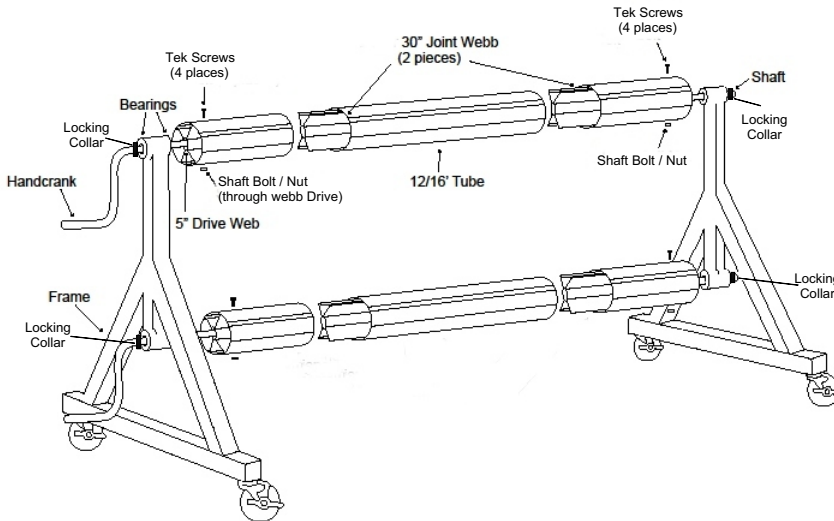

SINGLE TUBE MODELS
see below:
100/C14
100/C20
100/C24



DUAL TUBE MODELS
see below:
200/C14
200/C20
200/C24
100/C30

Commercial Models

Part#	DESCRIPTION	100/C14	200/C14	100/C20	100/C30	200/C20	100/C24	200/C24
3009	5' Commercial Anodized Aluminum Tube	0	0	2	0	4	2	4
3010	12' Commercial Anodized Aluminum Tube	0	0	1	0	2	0	0
3011	16' Commercial Anodized Aluminum Tube	1	2	0	2	0	1	2
3012	Commercial Frame (for Single Tube Assembly)	2	0	2	0	0	2	0
3013	Commercial Frame (for Dual Tube Assembly)	0	2	0	2	2	0	2
3020	5" Drive Webb (Aluminum Commercial)	2	4	0	4	4	2	4
3022	30" Joint Webb (Aluminum Commercial)	0	0	2	0	4	0	0
3054	Tek Screws (For Tubing)	8	16	40	80	80	80	80
3068	1.5" Bolt & .25" Nut	2	4	2	4	4	2	4
3060	Aluminum Collar (with set screw)	2	4	2	4	4	2	4
3061	Heavy Duty Aluminum Bearing	4	8	4	8	8	4	8
5005	Aluminum Handcrank	1	2	1	2	2	1	2
5006	Aluminum Shaft	1	2	1	2	2	1	2
5007	4" Heavy Duty Locking Casters	4	4	4	4	4	4	4
7010	Inground Cover Kit	1	2	1	2	2	1	2

HORIZON COMMERCIAL REEL ASSEMBLY INSTRUCTIONS

Read all instructions carefully and study appropriate Diagram before you start assembly.

TUBE ASSEMBLY:

- If a 1 piece tube is used with a Single or Dual Tube Reel Frame, no tube assembly is required. This includes the HV-100/C14, HV-200/C14 and the HV-100/C30. All other Reels have 3 piece tubes
- 3 piece tubes use either a 12' long or 16' long center tube and two - 5' end tubes. The 5' tubes will have the Joint Webb inserted and attached at the factory.
Please note the pattern of the tek screws used to secure the joint webb into the 5' tubes and use this same pattern to secure the joint webb to the center tube.
- For 3 piece tubes lay the 3 tube sections End to End with the long piece in the center. Lay the 5' tubes on either side with the joint webb facing the center tube.
- Insert the joint webb into the center tube and butt the seam tightly. Make sure joint webb slides into channel on inside of tube - in the very same way as the factory installed joint webb.
- Drill pilot holes through the center tube and joint webb using the scribe marks on the tube to locate these holes. The holes should be space 1 inch in and 11 inches in from the seam where the tubes butt. Do this on 4 sides of the tube - you may use the same pattern as used on the 5' tubes.
- Securely screw in and tighten self-tapping screws in these holes.
- Repeat this process on the other end of the center tube(s) to complete tube assembly.

REEL END ASSEMBLY:

- Press 2 Flange Bearings into the 2" diameter frame collar. These round frame collars are welded in place at the top of the frame for single tube reels and also in the center of the frame to accommodate a dual tube reel.
- The flange bearings do not have to be tight in the frame collar. If a flange bearing is loose it can be secured in place in the next assembly step.
- Determine which end of the reel should have the crank handle. The crank handle locking collar should be placed on the crank handle first so that it is on the outside of the frame. Then insert the shaft of the crank handle through the flange bearings in the frame collar at the top of the frame.
- Place a drive webb on the shaft of the crank handle and line up the hole in the shaft with the hole in the drive webb and secure with a 1.5" bolt and .25" nut provided.
- Press the drive webb snugly against the inside of the frame. Move the crank handle locking collar snugly up against the outside of the frame. Tighten the set screw.
- Next, using the second frame, insert the straight shaft through the 2 flange bearings at the top of the frame. Place the second drive webb on this shaft and line up the hole in the shaft with the hole in the drive webb and secure with a 1.5" bolt and .25" nut provided.
- Press the inside of the second frame snugly against the drive web. Move the straight shaft locking collar snugly up against the outside of the frame. Tighten the set screw.
- For DUAL TUBE reel systems repeat the above steps using the frame collars at the bottom center of the frames

FINAL REEL SYSTEM ASSEMBLY:

- With a helper, slide the tube (or tubes if a Dual Tube Reel is used) onto the drive webb of one of the reel end assemblies. Align end of tube flush with the end of drive webb
- Again with a helper, slide the other end of the tube (or tubes) onto the drive webb of the second reel end assembly. Align end of tube flush with the end of drive webb
- Drill 4 pilot holes through the tube and into the legs of the drive webb at each end. Secure the tube(s) to the drive webb(s) with self-tapping tek screws.
- Lift the reel at one end and insert the threaded stem of 2 casters completely through the holes in the base of the reel frame. Secure and tighten the casters with the 7/16" nuts provided.
- Repeat this caster attachment process at the other frame of the reel system.
- Instructions for attaching the solar blanket to the tube(s) using the straps are included in the strap and hardware package.