

THE ELITE REEL SYSTEM

HV-18 / HV-24 / HV-28 Assembly and Operation Instructions

- ** HV-18 - For Aboveground Pools up to 18' Width ****
**** HV-24 - For Aboveground Pools up to 19' to 24' Width ****
**** HV-28 - For Aboveground Pools up to 25' to 28' Width ****

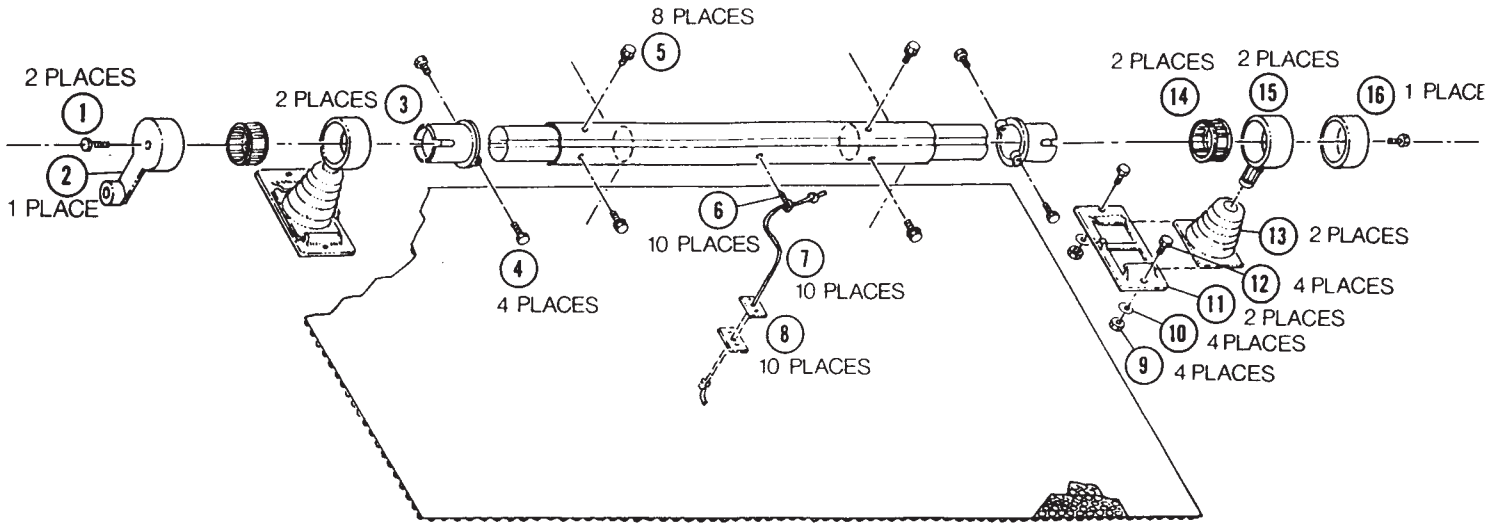

TOOLS REQUIRED

- | | | |
|---|---|-------------------------|
| 1a. Power Drill | 2. Hex Socket Wrench with
7/16" Hex Socket | 3. Phillips Screwdriver |
| 1b. Metal Cutting Drill Bits
1/8", 1/4", 5/32", 1/2" | | 4. Magic Marker Pen |

HV-18/24/28 PARTS LIST

PART DESCRIPTION	PART #	QTY.	PART DESCRIPTION	PART #	QTY.
1. Handwheel Screw (1-1/4)	3054	2	9. Base Mount Nut	3052	4
2. Handcrank (w/knob)	2015	1	10. Base Mount Washer	3053	4
3. End Cap	2002	2	11. Base Mount	2012	2
4. End Cap Screw (3/4")	3055	4	12. Base Mount Bolt	3051	4
5. Neoprene Tube Fastener	3056	8	13. HV-18/24/28 Base	2010	2
6. Tube Eye Screws	3050	10	14. Bearing (L)	2006	2
7. 2 Ft. White Cord	5004	10	15. Yoke	2011	2
8. Cord Plate (Set)	2008	10	16. Yoke Cap	2013	1

PARTS UNIQUE TO EACH SYSTEM

HV-18			HV-24			HV-28		
Description	Part #	Qty.	Description	Part #	Qty.	Description	Part #	Qty.
17. 7'0" Tube (O)	3004	1	17. 8'11" Tube (O)	3006	1	17. 10'3" Tube (O)	3008	1
18. 7'0" Tube (I)	3003	2	18. 8'11" Tube (I)	3005	2	18. 10'3" Tube (I)	3007	2

I. PLACEMENT OF REELS

Round Pool: Install reel in the center of your pool.
Oval Pool: Install reel near the end of pool before radius.

NOTE: Make certain there is a flat surface on the top rail and that there is no obstruction under top rail to prevent mounting the base mount.

II. DETERMINING TUBE LENGTH

NOTES:

A) Both lengths of "A" should always be equal, and never exceed the following:

HV-18: 5' 10"
HV-24: 7' 8"
HV-28: 9' 2"

B) If your pool is less than 13' wide, you must cut the inner tube with hacksaw to shorten its length.

1. Measure your pool's width. From inside edge of pool's top rails.
2. Place sections #1 & #3 into section #2. Slide sections #1 & #3 out to the desired TOTAL tube length.

(Total tube length is usually the pool width + 9")

III. ASSEMBLY OF TUBING

(Refer to Diagram #2)

1. To fasten tubing, you must always use Section #2 for measurements. Measure 3" from the left end of Section #2, and mark on tube. Use power drill and a sharp 1/2" metal drill bit. Using the groove in the center of tube for reference, drill a hole through section #2 and section #1. Place tube neoprene fastener into the hole. Use a hex socket wrench with 7/16" socket and tighten hex head bolt down completely. (Refer to Step #1/Diagram #2)
2. Rotate tubes 90 degrees, measure 10" from left end of section #2. Drill hole through section #2 and section #1, place tube neoprene fastener into hole and tighten completely. (Refer to Step #2)
3. Rotate tubes another 90 degrees, measure 3" from left end of section #2. Drill hole through section #2 and section #1, place tube neoprene fastener into hole and tighten completely. (Refer to Step #3)
4. Rotate tubes another 90 degrees, measure 10" from left end of section #2. Repeat directions of Step #2.
5. Go back to all the tube fasteners and re-tighten.
6. To fasten Section #2 and Section #3 together, take measurements from right end of section #2, then follow steps #1-5.

IV. ATTACH END CAP

(Refer to Diagram #3)

1. Place End Cap (Part #2002) on end of section #1. Make sure end cap inserts line up with indentions of tubing. Using the end cap pre-drilled hole as a guide. Use power drill and 5/32" drill bit. Drill hole thru tube and fasten End Cap screw (Part #3005). Tighten screw down. Drill only 1 hole per End Cap. **DO NOT DRILL BOTH HOLES OF THE END CAP.** The 2nd hole is a spare, and is there for your convenience. To fasten End Cap to section #3 repeat previous directions.

DIAGRAM #1

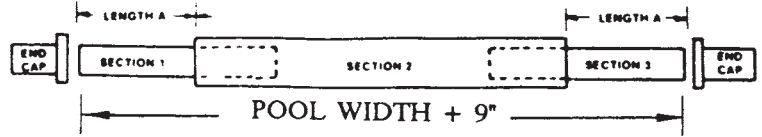

DIAGRAM #2

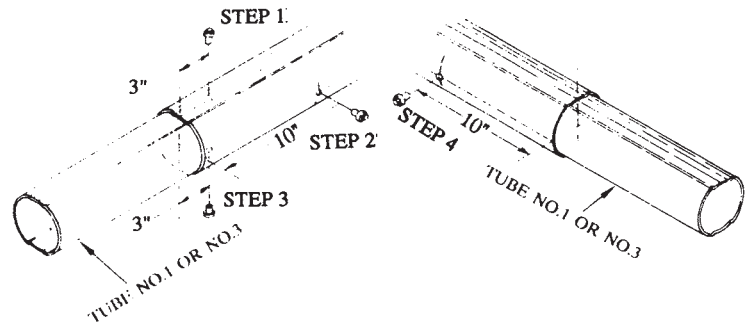
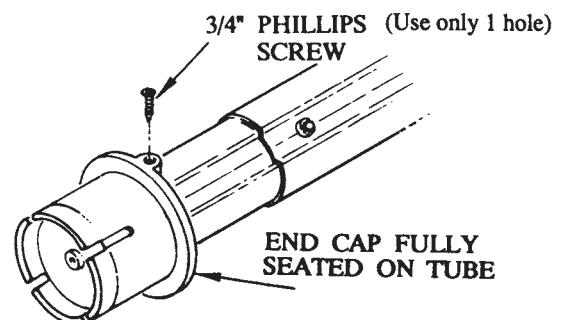

DIAGRAM #3



V. DRILL HOLES FOR TUBE EYE SCREWS

1. Measure 8" from end cap in towards the center of tube. Mark tube with magic marker. Do this on both sides of tubing.
2. Mark 8 equally spaced marks on the tube. (Diagram #4). Always mark in a straight line.
3. With power drill and 1/8" bit, drill a hole at each marked space.
4. Insert tube eye screw and tighten down. (DO NOT OVER-TIGHTEN)

VI. INSTALLING BASE MOUNT/HANDWHEEL/YOKE CAP

(Refer to Diagrams #5, #6, #7.)

1. Place each base mount onto top rail (The "STOP" should be positioned toward the pool).
2. Place bearing over end cap and insert into Yoke (Diagram #6).
3. Slide yoke into top of base and slide base into base mount until it hits "STOP".
4. Place handwheel onto end cap and secure with 1-1/4" handwheel screw.
5. Place Yoke Cap onto other end cap and secure with 1-1/4" handwheel screw. Always place the Handcrank on the most convenient side for cover rollup.
6. Place reel and base mounts onto top rail. This verifies the tubing is wide enough. Use magic marker and mark base mount holes.
7. With power drill and 1/4" bit drill 2 holes, using base mount as guide. Make sure base mounts are straight.
8. Insert 1" hex head base mount bolt into hole, place washer and nut under top rail. Tighten down with 7/16" hex socket. (Do both sides).

VII. ATTACHING THE SOLAR COVER TO REEL

(Refer to Diagram #8, #9.)

1. Your cover should be on the pool and the cover should be trimmed to inside of pool's top rail.
2. With a magic marker, place a mark at each edge of the cover directly below the tube.
3. Remove cover from pool and lay out on flat ground.
4. With a magic marker, draw a straight line between the two marks on the cover.
5. Roll cover up until you reach the drawn line.
6. Measure in 8 inches from each side of cover, and place a cross mark on the line.
7. From this position, take the measurement used between the first tube marks. (Diagram #8) and space cross marks down the line to the second 8 inch measurement.

VIII. ATTACHING THE CORD PLATES

(Refer to Diagram #10.)

1. Take one set (male and female) of the cord plates and place the female plate over the first cross, 8 inches from the cover edge. Make sure the center hole is placed above the cross. (Refer to Insert in Diagram #8).

DIAGRAM #4 TUBE SECTIONS

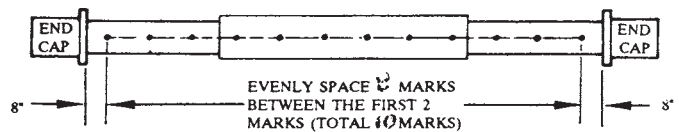

DIAGRAM #5

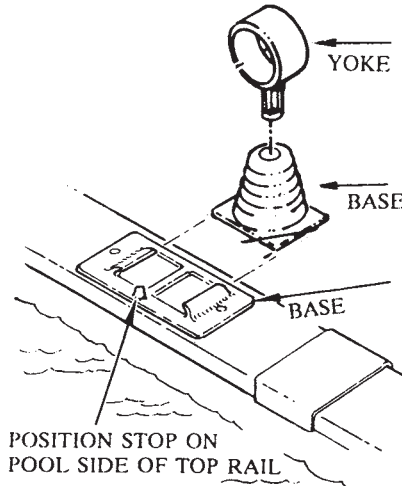

DIAGRAM #6

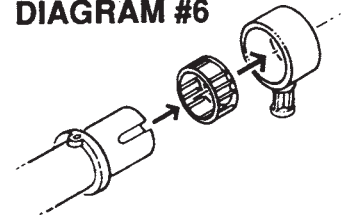

DIAGRAM #7

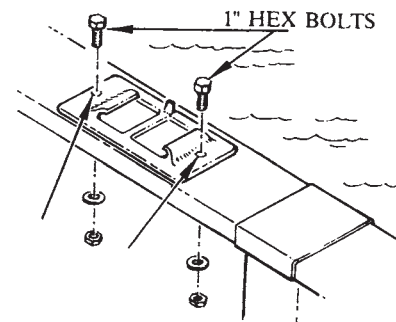

DIAGRAM #8

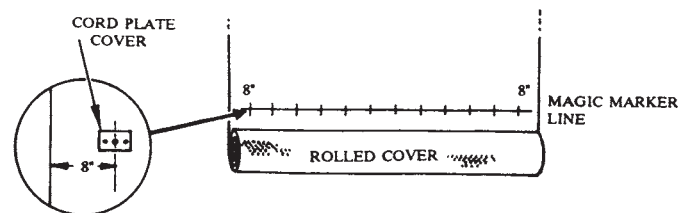
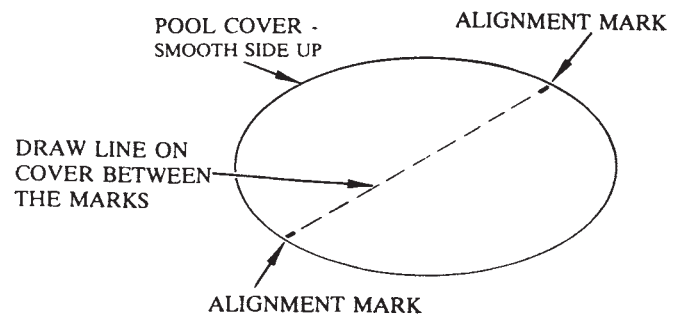

DIAGRAM #9



2. With a sharp instrument, punch 3 holes through the plate and cover. (Make certain the HOLES are clean of excess cover material.)
3. Place a male plate under the cover directly beneath the female plate.
4. Carefully insert the 2 male prongs through the cover and into female plate, then snap together. If the plates do not snap into position with normal force, remove all excess cover material. Repeat procedure until all plates have been installed.

IX. ATTACHING THE WHITE CORD

(Refer to Diagram #11.)

1. Place 2 foot white cord through the top of the female plate in center hole, and push through cover and male plate until enough cord remains to tie a knot below the male plate.
2. Tie a secure knot, large enough so that it cannot go through the center hole.
3. Install cover on the pool, attempting to keep one side in the rolled up position.
4. ENTER POOL. Attach top of the white cord through tube eye screws. **MAKE CERTAIN ALL CORDS HAVE THE SAME TENSION.** Then tie cord to tube eye screw, being careful to keep equal tension.

X. OPERATING INSTRUCTIONS

1. Slowly turn handwheel clockwise; the cover will be lifted up and over the tube. Should either cover edge be hampered by the top rail, straighten it out so that cover remains smooth and wrinkle-free during roll-up. **MAKE CERTAIN COVER IS REMOVED FROM THE POOL UNIFORMLY ONTO TUBE.**
2. When cover is completely rolled up on the tube, lift the handwheel, tube, and yoke and rotate system to any desired location.
3. If desired, the bases may now be removed from top rail and stored.

PLACING COVER BACK ON THE POOL

1. Turn handwheel counterclockwise until cover makes contact with the pool.
2. Separate the 2 edges of the cover from each other.
3. Grip cover edge and walk slowly down the pool to the end.
4. Roll out 5-8 feet of cover at a time.
5. Now walk the cover down to the end of pool. Repeat procedure for 2nd part of cover.

HELPFUL HINTS

Remove Handcrank & yoke cap at the beginning of each season. Clean yoke bushing, bearing race, and end cap with warm soapy water. Rinse, dry and reassemble.

STORAGE

Always store the reel with an eye for safety.

MANUFACTURER IS NOT RESPONSIBLE FOR ACCIDENTS OR DAMAGE RESULTING FROM UNSAFE STORAGE.

