

ATLANTIS® SMALL FILTRATION UNIT

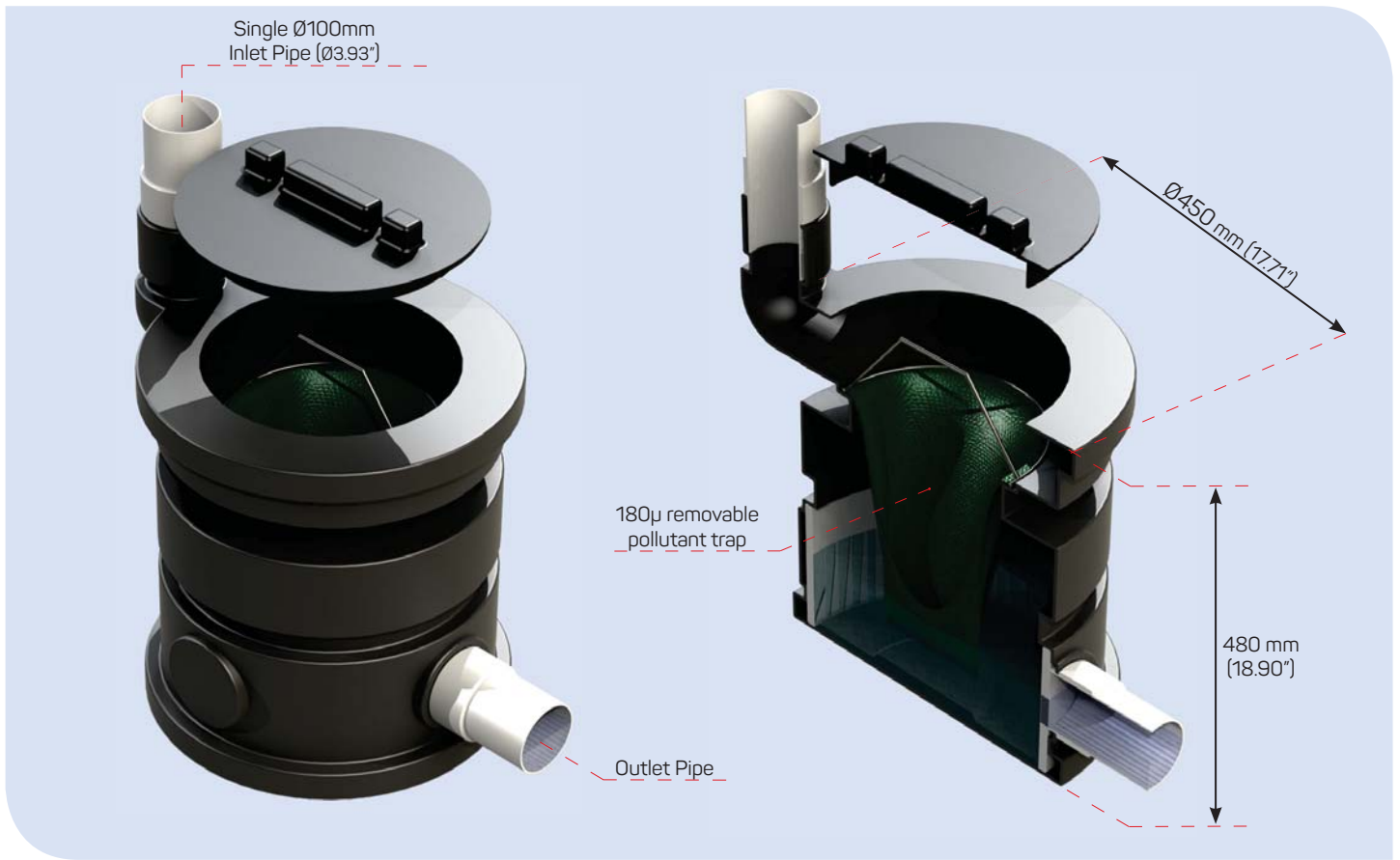

Part Number	60002(A)			
Size	Width		Height	
	Ø 450 mm	Ø 17.71 in	480 mm	18.90 in
Flow Capacity	Up to 12 L / sec.		190.20 US Gallons / minute	
Part Weight	21 kg		46.30 lbs	
Filter Mesh	180 micron detachable trash screen			
Drum Material	85 % Recycled polypropylene, 15% Atlantis Proprietary selected materials			
Lid Material	85 % Recycled polypropylene, 15% Atlantis Proprietary selected materials			
Pipe Connections	1 inlet of Ø90 mm (Ø3.54")		1 inlet of Ø100 mm (Ø3.93")	
Colour	Black			
Chemical and Biological Resistance	Unaffected by moulds and algae soil-borne chemicals, bacteria and bitumen			
Service Temperature	-30°C to 120°C		-22 F° to 248 F°	
Approximate Material Lifespan	100 years + (Note: With underground tank installations)			

Note: Please contact Atlantis® technical team for advice on filtration requirements.