

Atlantis Product Guide

UNDERGROUND TANKS | VERTICAL DRAINAGE | TRENCH DRAINAGE | LANDSCAPE DRAINAGE
VERTICAL GARDEN SYSTEMS | TURF REINFORCEMENT | GRAVEL REINFORCEMENT



www.atlantiscorp.com.au



Atlantis - Green Cities for Life

Company Profile

Atlantis was formed in 1986 by Landscape Architect, Humberto Urriola following his dream of creating Green Cities.

Green City Vision

In the early 1970's Humberto developed a vision to cover cities with beautiful landscaped gardens. Buildings would be covered with hanging gardens, rooftops with intensive gardens and parks & gardens added to the urban landscape. The Green Cities would be part of a new urban cycle that improves water quality, reduces contaminated runoff, improves air quality, reduces the heat island effect and improves the mental health of the population.



We believe in creating Green Cities For Life a complementary relationship between urban development and the environment.

The Beginning - The Original Drainage Cell

As a Landscape Architect, Humberto found many challenges in the design of intensive roof gardens due to the weight restrictions on structural roof tops. Soil profiles needed to meet certain weight targets and the traditional drainage layer of aggregate was simply too heavy. Humberto began designing a new solution that was structural and lightweight.



In 1986 the final design was ready and placed into production, the product was an injected moulded part made from recycled polypropylene. It was a 40mm thick offset chessboard pattern design which was named Drainage Cell. Today the 30mm drainage cell has become an industry standard. This product commenced the journey of the Atlantis brand into the market place. Many more inventions by the Atlantis team have since grown our product range and our team is dedicated to continuous innovation.

Mission Statement

Atlantis is dedicated to manufacture products to enhance the environment and provide solutions that are sustainable. Our vision is to manufacture quality products to build green cities, sustainable developments that mimic the natural environmental cycles of air, water and climate.

We believe in making a difference. The coexistence between nature and humanity is the key to sustainability. Atlantis stands for quality, innovation, and delivering solutions that work.

Manufacturing, Environment & Sustainability.

Atlantis products are manufactured in facilities located in Australia, Asia, USA, Europe and South America. High quality resins are sourced from accredited recycled material suppliers providing Atlantis with certified recycled polypropylene that is free from chemical contaminants.

The factories producing Atlantis products are committed to processes that have a minimal impact on the environment and are compliant with quality certification ISO 9001:2008.

NEW Atlantis Service

Environmental Design Construct

Atlantis Aurora is our new division which provides consultancy, design, supply and installation of specialised applications.



Underground Tanks

For underground Infiltration, Detention, Rainwater Harvesting & Channel applications...

The Atlantis Flo-Tank® system provides underground water storage of unlimited capacity and can be installed in various volumes, shapes and depths to meet specific project requirements.

The entire project location can be used as a catchment area including stormwater, landscape and roof areas providing the water storage capacity to meet your requirements.

Suitable for both residential and commercial installation projects, the Flo-Tank® system maximizes land usage and minimizes stormwater runoff.

Atlantis Flo-Tank® system provides unlimited storage and flexible design to meet your water requirements.

Atlantis Flo-Tank® and Flo-Channel® are suitable for the following applications;

Applications

- Infiltration Tanks
- Stormwater Harvesting
- Re-Use Tanks
- Detention Tanks (Attenuation)
- Channels
- Soak Wells
- Leach Drains
- Drainage Channels

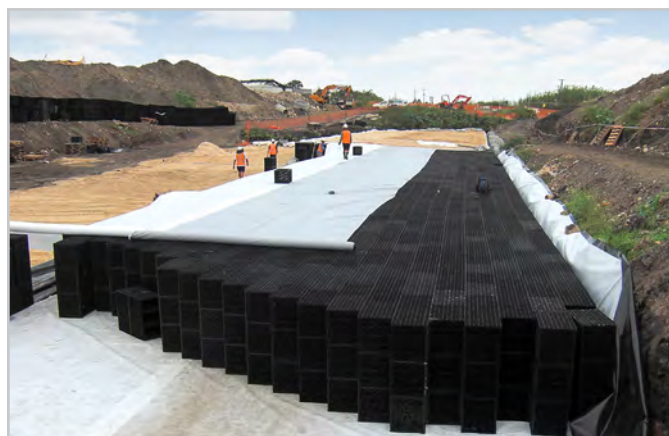
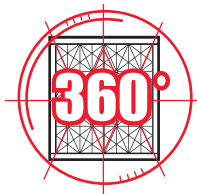

Benefits

Quick Installation

- Reduce site access delays.

Lightweight

- No cranes or lifting equipment required.

Modular

- Easily create any shape and size to suit site requirements.

Maintenance Free Tank

- All debris and sediment is removed by pre-filtration.

Determinate Volume

- One cubic metre of Flo-Tank® Modules contain 950 litres of water.

Cost Effective

- Reduces excavation and disposal by two thirds compared with conventional soak wells.
- Cost effective compared to concrete and other systems

High Infiltration

- 95% void surface area

Easily Transportable

- Can be supplied unassembled for delivery to remote areas.

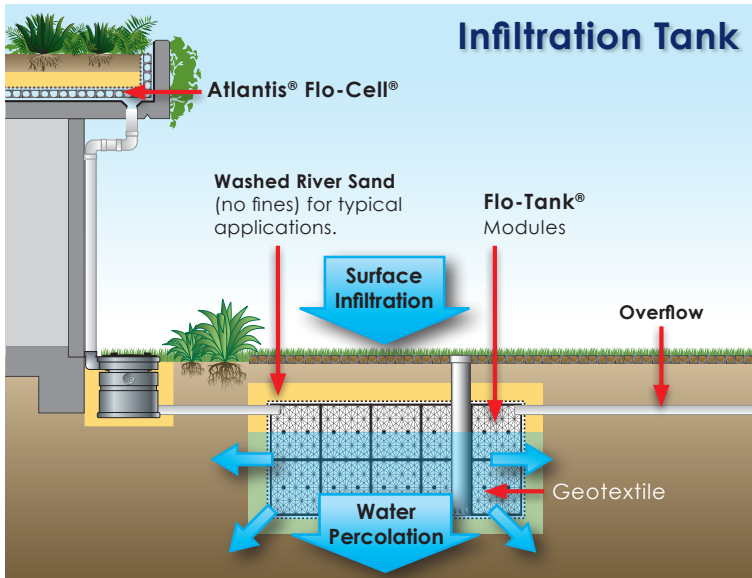

INFILTRATION TANK

The infiltration tank system is the ideal way to manage stormwater runoff in permeable or semi-permeable soil conditions.

How It Works!

The system is designed to capture surface water through infiltration, and then clean and filter the water before it is allowed to recharge the water table providing moisture for surrounding vegetation. The Atlantis® Filtration Unit also captures and cleans roof water before entry into the storage area (Flo-Tank™ Modules).

Applications: New developments required to meet water sensitive urban design standards.

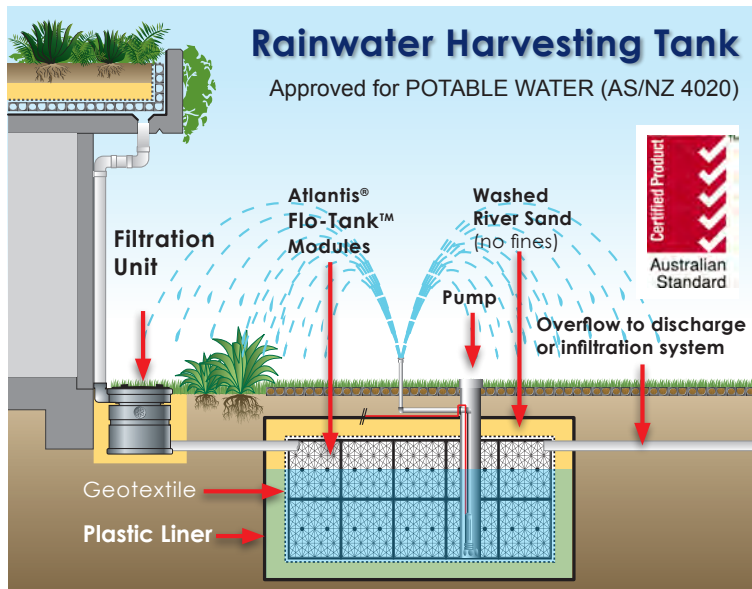

RAINWATER HARVESTING (RE-USE TANK)

The Atlantis® Re-use System has proven effective in providing a regular clean water supply for domestic and commercial applications.

How It Works!

The system captures water from both landscaped areas through surface infiltration and from roof areas which are filtered through an Atlantis® Filtration Unit. Clean water is retained within the storage area away from harmful U.V. light and heat remaining cool underground readily available for re-use.

Applications: Typical applications include flushing toilets, in washing machines, watering gardens and washing cars.

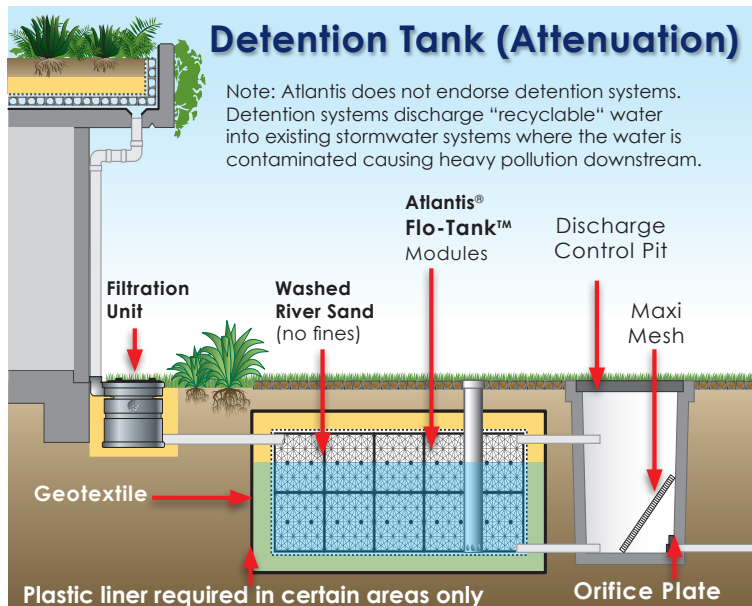

DETENTION TANK (ATTENUATION)

Note: Atlantis does not endorse detention systems. Detention systems discharge "recyclable" water into existing stormwater systems where the water is contaminated causing heavy pollution downstream.

The Atlantis® Detention System is a cost effective solution that can also address water quality. The system offers flexible design options, saving installation time and delays to site access.

How It Works!

Water captured from roof and paved areas are filtered through an Atlantis® Filtration Unit before entering the storage area (Flo-Tank™ Tank Modules). Water is then slowly released through the discharge control unit (DCU).

Applications: Developments that need to meet Local Council Stormwater requirements.

Vertical Gardens

Vertical Gardens Made Easy!

Atlantis vertical garden systems facilitates installation of vertical gardens in adverse outdoor environmental conditions and in regulated indoor environments with complete access and control.

Our vertical gardens systems provide targeted watering control of individual plants, maximum water efficiency, last minute design changes and easy access to irrigation components.

Benefits

- Rapid Construction
- Quick Plant Installation
- Vertical & Horizontal Expansion
- Easy Creative Planting Design
- Self Supporting Structure
- No Framework Required
- Structurally Strong
- Modular Planting System
- Optimum Moisture Retention for Plants
- Easy Individual Plant Access & Maintenance
- Excess Water Capture System Available



Gro-Wall® 4 installed onto coffee shop frontage in Kuala Lumpur, Malaysia.

Why Use Gro-Wall®



Water Efficient
Gro-Wall® is highly water efficient. The system can be tailored to water plants without excess runoff.



Earn LEED Points
Use Gro-Wall® to earn up to 23 valuable LEED points on your project.



IPI™ System
Gro-Wall® features individual plant irrigation system.



Thermal Insulator
Gro-Wall® performs as a thermal insulator for buildings, cooling in summer and retaining heat in winter.



Recycled Materials
Gro-Wall® is made from high quality recycled materials.



IFS™ System
Integrated frame work system. Gro-Wall® is fixed directly onto the wall. No additional framework is required.



Energy Savings
Save energy costs associated with running costly air conditioning.



Green Building
The Gro-Wall® system is ideal for improving the GREEN ratings of building design and long term sustainability.



Complete Access
Gro-Wall® allows complete & easy access to individual plants and irrigation components.



Sound Insulation
The Gro-Wall® 4 design is a highly effective sound insulator holding up to 140L of soil media per square metre.



Modular System
Gro-Wall® is a modular system allowing easy vertical and horizontal expansion.



Versatile Planting
Gro-Wall® 4 can accommodate a large variety of plant species including grasses, Sedums, Succulents.

Gro-Wall® 4

Gro-Wall® features Gro-Pot™ planter trays that can accommodate single or multiple plants including small plants and grasses. Each Gro-Pot™ tray has built in drainage and a small water reservoir. The Gro-Pot™ can hold up to 6.5L of soil media and is compatible with all versions of Gro-Wall® including the PRO version.



Gro-Wall® PRO

Gro-Wall® PRO is a versatile living wall system designed to construct robust living walls such as double sided landscaped walls, cascading living walls and living walls requiring intensive soil depth.



Gro-Wall® PRO features channel conduits for steel reinforcement and the housing of irrigation systems. The channels can be used for multiple drip line or drip head irrigation systems for intensive watering applications. Gro-Wall® PRO also features a rigid wall mount clip for fixing to wall surface.



Installation of 148m² of Green Wall. The project utilises 1040 Gro-Wall® modules and 3120 plants.

Gro-Wall® Façade

The Gro-Wall® Façade system facilitates easy installation and integration with existing buildings and new architectural designs.

The strong design and ease of installation makes Gro-Wall® Façade an ideal choice for architects, landscape designers and landscape contractors.

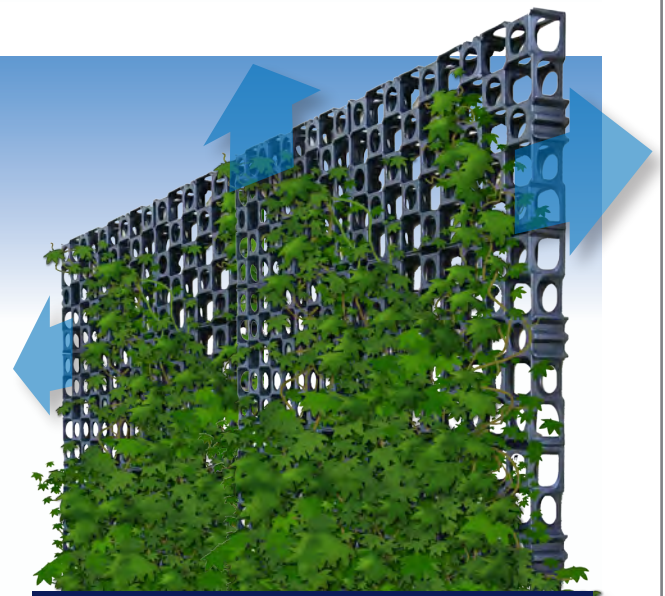

Expandable in all directions

Turf & Gravel Reinforcement

Atlantis Turf Cell® is an ideal product to reinforce grass in trafficable areas. Designed to house and protect grass, Turf Cell® enables rigorous horizontal and vertical root growth.

The strong design ensures long time durability and with an installed load capacity of 4000t/m² meets the majority of traffic requirements.



Horizontal & Vertical Root Growth

The Turf Cell® is also a great solution for increasing permeable surfaces around buildings, adding green space and lowering the Heat Island effect.

The Turf Cell® structure promotes root growth by maintaining regular surface temperature unlike concrete pavers that absorb and retain heat which scorch the grass roots.

Aesthetically the product allows the grass to fill in completely, creating a lush lawn with an invisible reinforcement structure.

Applications

- Access Roads
- Driveways
- Residential Parking
- Pathways
- Golf Buggy Trails
- Emergency Vehicle Access
- Aircraft Taxiways
- Helicopter Landing Pads

Turf Cell® at a glance.

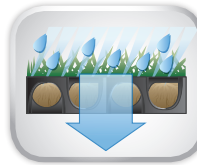

Permeable Surface

Permits surface water absorption and filtration.



Surface Temperature

Increased vegetation reduces ambient temperature around buildings.



High Water Quality

Turf Cell® installations function as water filters. Turf Cell® is ideal for releasing clean water into the environment.

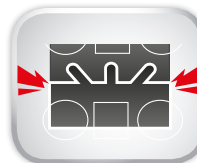

Rigid Clipping System

Unique easy to use interlocking system.



Cost Efficient

Turf Cell® installations are significantly more cost efficient than concrete or bitumen alternatives.



Made From Recycled Materials

Gravel Cell® is made from high grade recycled materials.



High Load Bearing

The installed Turf Cell® can hold weight over 3800 t/m²



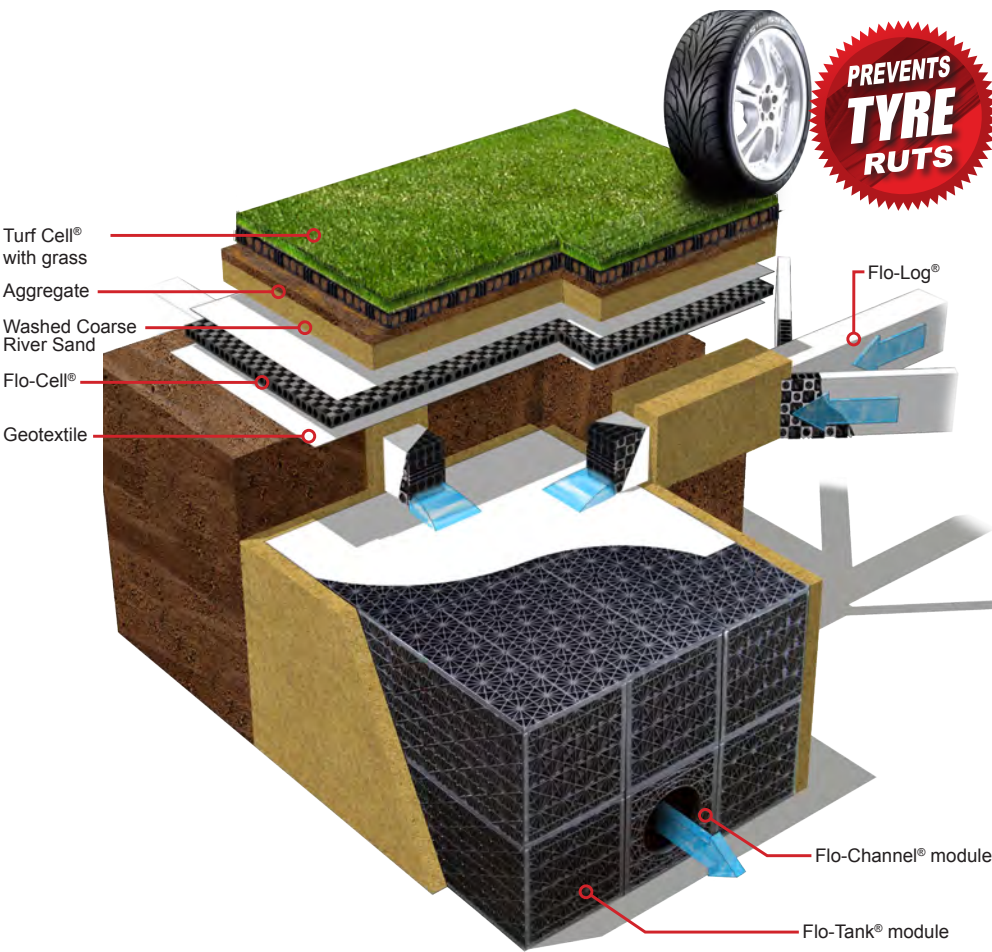

Adding **Flo-Cell®** and **Flo-Log®** ensures a regular free draining surface that can be utilised during the heaviest rainfall events.

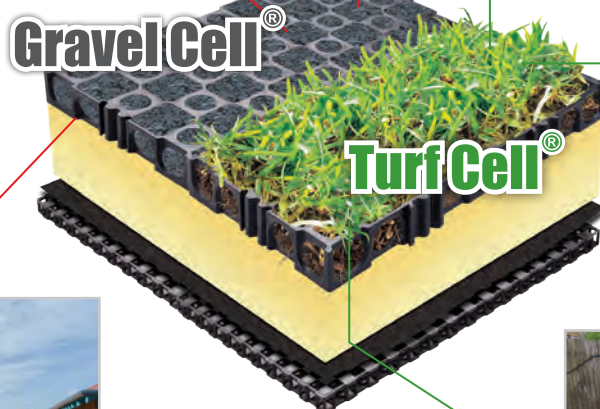

Landscape Drainage

HIGH STRENGTH, HIGH FLOW DRAINAGE

The Original Since 1986

Since the original release in 1986, Atlantis® Drainage Cell set a benchmark for sub surface water management. Atlantis® Drainage Cell is the most advanced underground geo-composite and offers high compressive strength, lightweight construction, ease of installation and low cost compared to traditional methods.

Efficient Water Management

The Atlantis® Drainage Cell removes only excess water, keeping a perfect amount of moisture on perch. The unique design of the Atlantis® Drainage Cell also features water retention cups that provide optimal moisture conditions for growing media.

Long Life Durability

Atlantis® Drainage Cell has excellent long term durability and is resistant to all ground chemicals. Atlantis® Drainage Cell is manufactured from selected quality recycled materials and under stringent quality control ensuring a high quality product that will not collapse or distort if used correctly.



Planter Box Installation

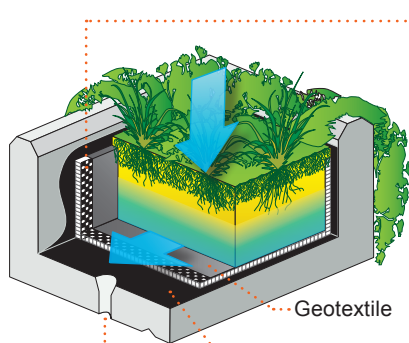

Atlantis® Drainage Cell only removes excess water, while retaining water in unique storage cups.



Protects Building Structures

The Atlantis® Drainage Cell, used in conjunction with Atlantis® Geotextile, functions as a protective membrane for waterproofing and providing ventilation for concrete slabs which alleviates heat induced stress and cracking.

Lightweight Structural Void Fill

Ideal for creating landscape mounds, structural fill for planter boxes, podiums and roof top gardens,

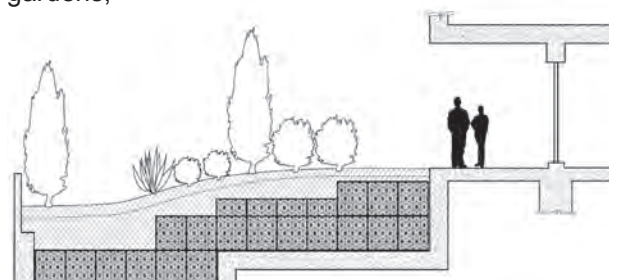

Podium Landscaping

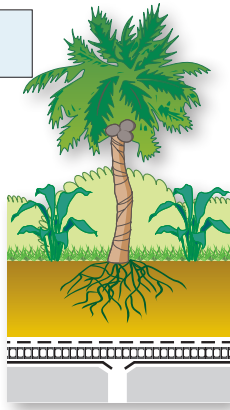

Drainage Under Concrete Slab

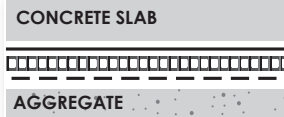

Roof Garden / Green Roof

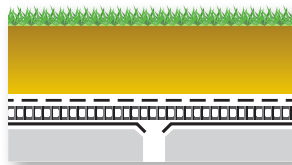

Lightweight Structural Void Fill

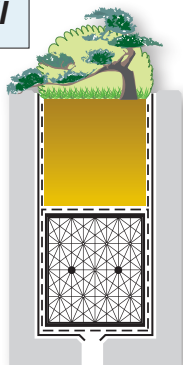

Installing Flo-Tank® modules into planter box.

Wall Drainage

Flo-Wall® wall drainage panels

HIGH STRENGTH, HIGH FLOW WALL DRAINAGE

RAPID DRAINAGE

The Atlantis Flo-Wall® range is ideal for the rapid drainage of saturated ground. The Flo-Wall® range is suited for applications including underground car parks, basements, retaining walls and seepage cutoff trenches.

HIGH STRENGTH

The Atlantis Flo-Wall® range features high compressive strength that will not crush over time ensuring long term drainage performance.

HYDROPHILIC GEOTEXTILE

The Flo-Wall® range are prefabricated products wrapped with a high quality Italian made geotextile with hydrophilic properties for effective drainage that does not require a head of pressure to perform.

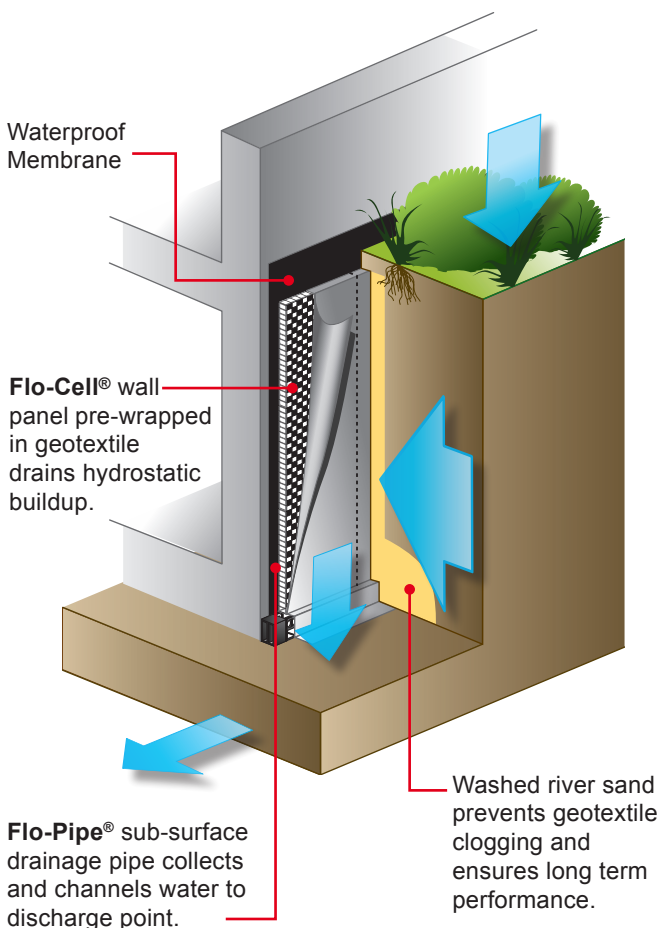

LONG TERM
**STRUCTURAL
& DRAINAGE**
PERFORMANCE



UNLIMITED LENGTH

The Atlantis Flo-Wall® range can be easily connected together to form the lengths required for the project. Each Flo-Wall® is provided with an overlap allowance of geotextile to allow each connection to be appropriately sealed with tape.



MULTIPLE APPLICATIONS

The Flo-Wall® range is suitable for retaining walls, foundation walls, basements, underground car parks, bridge abutments, civil structures, tunnels and anywhere hydrostatic pressure relief is required.



“Save time & labour while getting the job done right the first time”



The product is ideal for shotcreting saving time and labour costs through rapid installation and thereby reducing labour requirements.



Steel reinforcement is placed over Atlantis Wall Panels.



Tradesman applying shotcrete over steel reinforcement and Atlantis Wall Panels.

Trench Drainage

Flo-Log® trench & strip drainage

PRE FABRICATED HIGH STRENGTH, HIGH FLOW STRIP DRAINAGE

RAPID DRAINAGE

The Atlantis Flo-Log® range is ideal for the rapid drainage of saturated ground. The Flo-Log® range is suited for applications requiring strip or trench drainage.

HIGH STRENGTH

The Atlantis Flo-Log® range features high compressive strength that will not crush over time ensuring long term drainage performance.

HYDROPHILIC GEOTEXTILE

The Flo-Log® range are prefabricated products wrapped with a high quality Italian made geotextile with hydrophilic properties for effective drainage that does not require a head of pressure to perform.

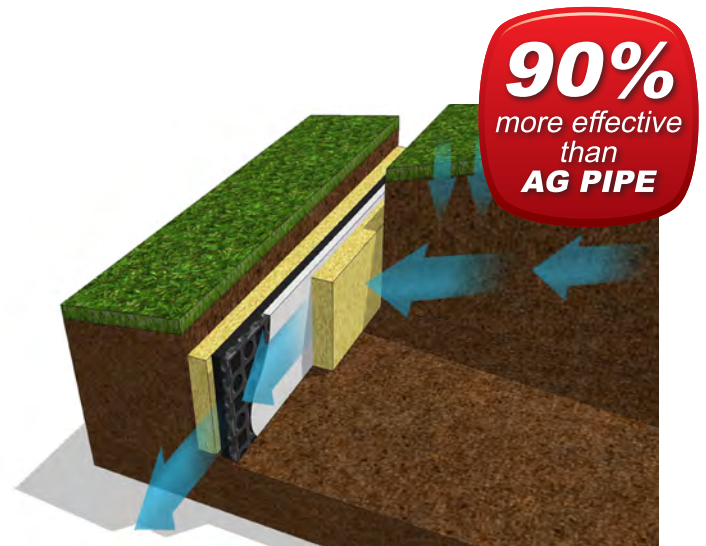

UNLIMITED LENGTH

The Atlantis Flo-Log® range can be easily connected together to form the lengths required for the project. Each Flo-Log® is provided with an overlap of geotextile to allow each connection to be appropriately sealed with tape.

20mm Flo-Cell® Drainage Cell (W-Clip)

Part Number	80020
Material	85% Recycled PP, 15% Proprietary Materials
Width	400mm (15.75")
Height	20mm (0.79")
Length	620mm (24.41")
Part Weight	550 grams (19.4 oz.)
Weight m² ft²	2.19 kg/m ² (0.45 lb/10.76 ft ²)
Flow Rate	4.44 L/s/m (21.48 Gal/min/ft) @ 0.5% gradient
Pieces per m² / (ft²)	4 / (16.76)
Compressive Strength	90 t/m ² (128 psi)

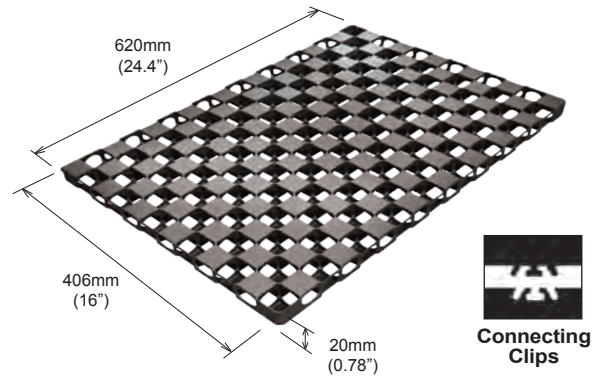

30mm Flo-Cell® Drainage Cell (W-Clip)

Part Number	80030
Material	85% Recycled PP, 15% Proprietary Materials
Width	400mm (15.75")
Height	30mm (1.18")
Length	620mm (24.41")
Part Weight	670 grams (23.6 oz.)
Weight m² ft²	2.66 kg / m ² (0.54 lb/ ft ²)
Flow Rate	7.4 L/s/m (35.8 Gal/min/ft) @ 0.5% gradient
Pieces per m² / (ft²)	4 / (16.76)
Compressive Strength	98.6 t/m ² (140.3 psi)

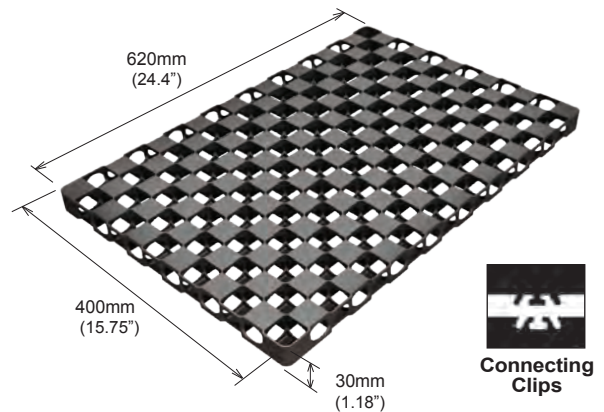

30mm Atlantis Drainage Cell (T-Clip) The Original Since 1986

Part Number	80030-M
Material	85% Recycled PP, 15% Proprietary Materials
Size	(T)30 x (W)406 x (H)605
Width	406mm (16")
Height	30mm (1.18")
Length	607mm (23.9")
Part Weight	710 grams (25 oz.)
Weight m² ft²	2.89 kg/ m ² (6.37 lb/10.76 ft ²)
Flow Rate	7.4 L/s/m (35.8 Gal/min/ft) @ 0.5% gradient
Pieces per m² / (ft²)	4 / (16.76)
Compressive Strength	76 t/m ² (108 psi)

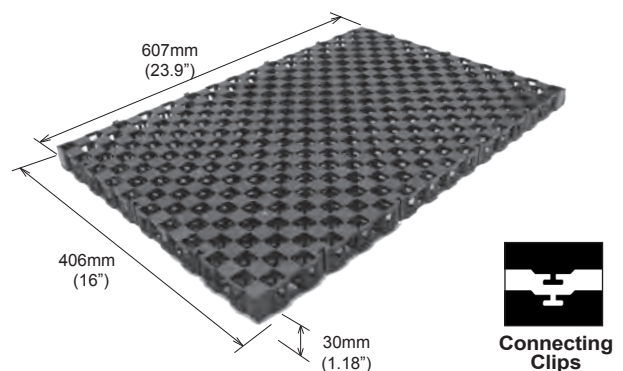

Flo-Cell® 52mm (2.04")

Part Number	80052
Material	85% Recycled PP, 15% Proprietary Materials
Width	260mm (10.2")
Height	52mm (2.04")
Length	480mm (18.9")
Part Weight	680 grams (24 oz.)
Weight m² ft²	5.44 kg/m ² (12 lb/10.76 ft ²)
Flow Rate	17.1 L/s/m (82.6 Gal/min/ft) @ 0.5% gradient
Pieces per m² (10.76ft²)	8
Compressive Strength	130.6 t/m ² (185.8 psi)

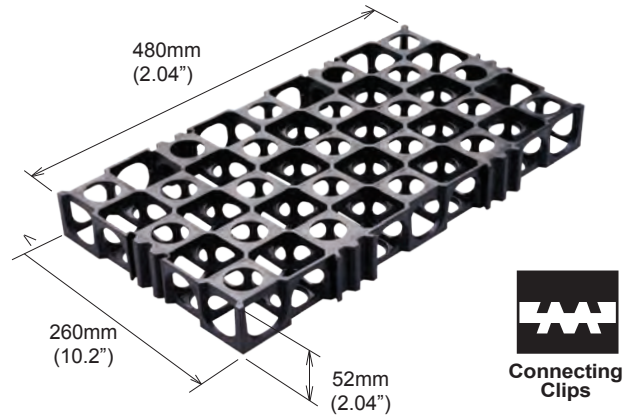

Flo-Cell® 52mm (2.04") W-Clip Facade

Part Number	80052F
Material	85% Recycled PP, 15% Proprietary Materials
Width	264mm (10.39")
Height	52mm (2.04")
Length	484mm (19.05")
Part Weight	625 grams (22 oz.)
Weight m² ft²	5 kg/m ² (11 lb/10.76 ft ²)
Flow Rate	17.1 L/s/m (82.6 Gal/min/ft) @ 0.5% gradient
Pieces per m² (10.76ft²)	8
Compressive Strength	130.6 t/m ² (185.8 psi)

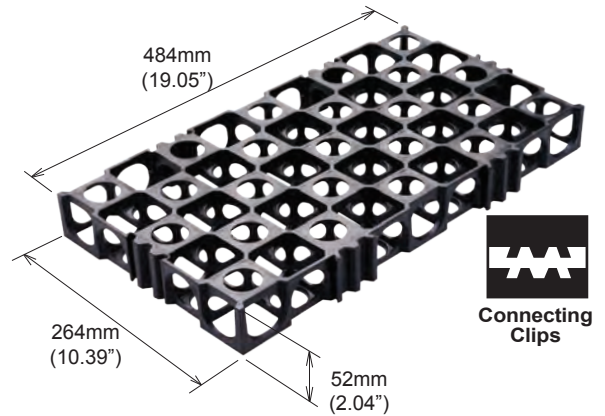

Road Cell®

Part Number	80052HD
Material	85% Recycled PP, 15% Proprietary Materials
Width	260mm (10.2")
Height	52mm (2.04")
Length	480mm (18.9")
Part Weight	1.140 kg/ (40.2 oz)
Weight m² ft²	9.12 kg/m ² (20.12 lb/10.76 ft ²)
Flow Rate	17.1 L/s/m (82.6 Gal/min/ft) @ 0.5% gradient
Pieces per m² (10.76ft²)	8
Compressive Strength	255.2 t/m ² (363.1 psi)

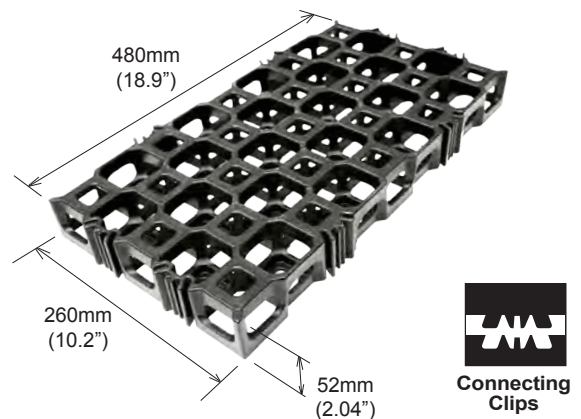

Flo-Grid® Porous Paver

Part Number	80008
Material	85% Recycled PP, 15% Proprietary Materials
Width	400mm (15.7")
Height	50mm (1.96")
Length	685mm (26.9")
Part Weight	2.42 kg/ (85.4 oz)
Weight m² ft²	8.85 kg/m ² (19.51 lb/10.76 ft ²)
Pieces per m² (10.76ft²)	3.65
Compressive Strength	247 t/m ² (351.4 psi)

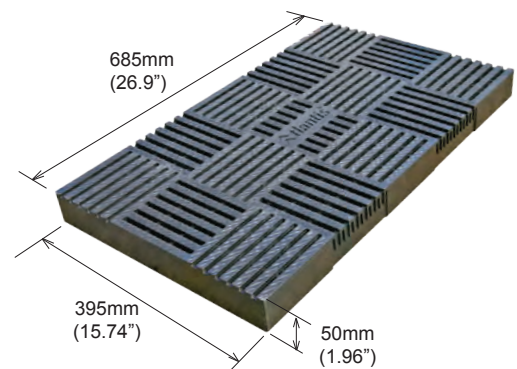

ATLANTIS FLO-TANK MODULE SPECIFICATIONS

	MINI	SINGLE	DOUBLE	TRIPLE	QUAD	PENTA	Common Measurements
Height in mm	240 (9.45")	450 (17.72")	880 (34.65")	1310 (51.57")	1740 (68.5")	2170 (85.43")	Length: 685 mm (26.77")
Water Storage in L	64.58	119.47	233.64	347.80	461.93	576.10	Width: 408 mm (16.06")
Water Storage in Gal	17.06	31.56	61.72	91.88	122.03	152.19	Module Footprint: 0.2795 m ²
							Module Footprint: 3 ft ²

ATLANTIS FLO-TANK® TOP COVER & BACKFILL RECOMMENDED REQUIREMENTS

	Pedestrian Traffic	Vehicle Traffic
Base Fill	100mm (4")	100mm (4")
Backfill Height*	300 - 500mm (12" - 20")	600 - 1600mm (24" - 63")
Side Backfill**	200 - 500mm (10" - 20")	200 - 500mm (10" - 20")

SIDE BACKFILL**

For installations that have limited footprint available, 100mm (4") can be applied if approved by specifying engineer. For installations into reactive soils or clay a minimum of 500mm (20") side backfill is required.

MAXIMUM BACKFILL: The maximum backfill allowed is 1600mm (5.3 ft). For further information please contact our technical department.

Material Properties

- **Void Ratio:** 95% void (approximately)
- **Material:** 85% Recycled PP, 15% Proprietary Materials

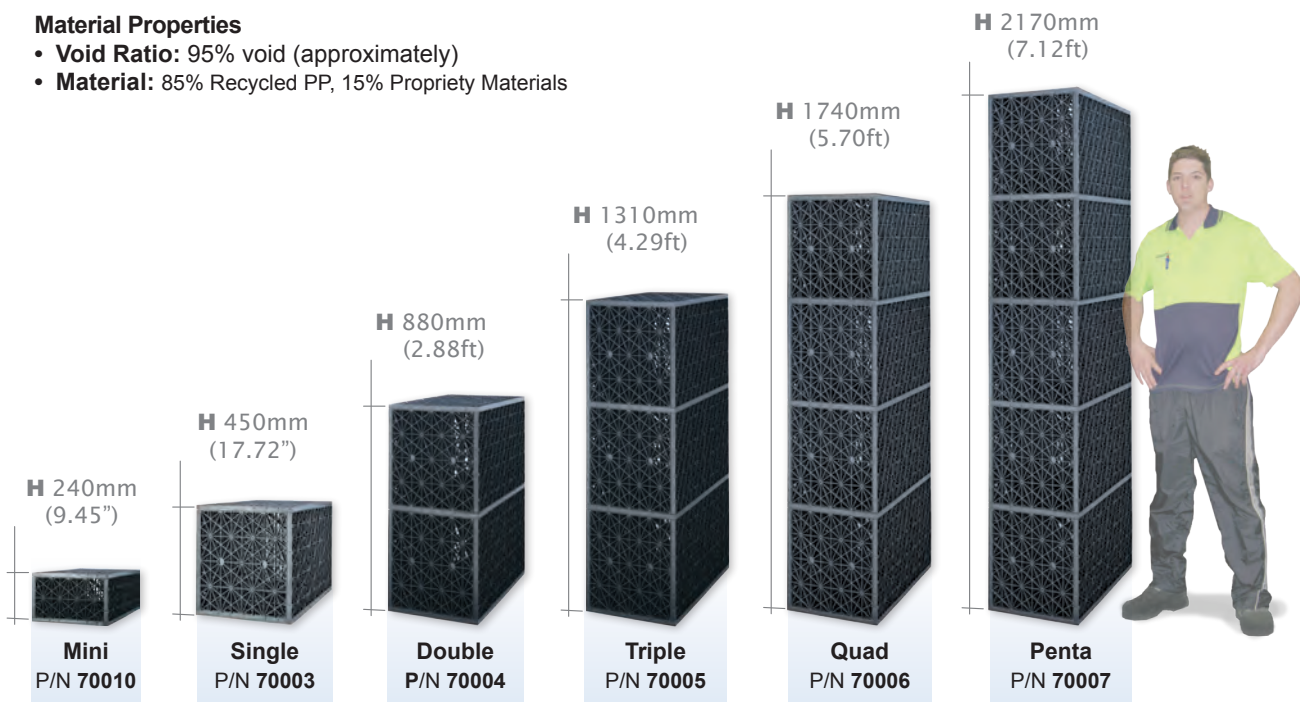

For further technical details, please contact our technical department: technical@atlantiscorp.com.au

- Maximum Flow Rate @ 1% gradient** 11.5 L/s (3.038 USGal/s)
- Maximum Flow Rate @ 5% gradient** 27.4 L/s (7.238 USGal/s)
- Maximum Flow Rate @ 10% gradient** 39 L/s (10.303 USGal/s)

ATLANTIS FLO-CHANNEL TANK MODULE SPECIFICATIONS

	MINI	SINGLE	DOUBLE	TRIPLE	QUAD	PENTA	Common Measurements
Height in mm	240 (9.45")	450 (17.72")	880 (34.65")	1310 (51.57")	1740 (68.5")	2170 (85.43")	Length: 685 mm (26.77")
Water Storage in L	64.58	119.47	233.64	347.80	461.93	576.10	Width: 408 mm (16.06")
Water Storage in Gal	17.06	31.56	61.72	91.88	122.03	152.19	Module Footprint: 0.2795 m ²
							Module Footprint: 3 ft ²

For excavation and backfill requirements see Flo-Tank Module Specs

Material Properties

- **Void Ratio:** 95% void (approximately)
- **Material:** 85% Recycled PP, 15% Proprietary Materials

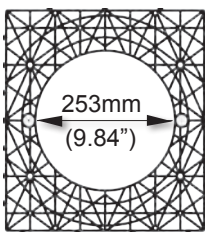

The module opening has a diameter of 253mm (9.84")

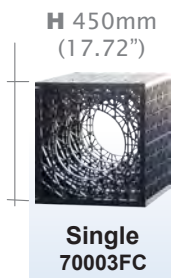

For further technical details, please contact our technical department: technical@atlantiscorp.com.au

- Maximum Flow Rate @ 1% gradient 28.5 L/s (7.5 USGal/s)**
- Maximum Flow Rate @ 5% gradient 89.7 L/s (23.7 USGal/s)**
- Maximum Flow Rate @ 10% gradient 148 L/s (39 USGal/s)**

Common Properties	
Biological Resistance:	Not affected by biological activity
Chemical Resistance:	Excellent resistance to, Acids, Alcohols, Bases and Mineral Oils. Good resistance to Aliphatic Hydrocarbons, Ketones and Vegetable Oils.
Recommended Service Temperature:	-10°C to 70°C (14 °F to 158 °F)

Gro-Wall® 4 Specifications

Part Number	80040
Material	85% Recycled PP, 15% Propriety Materials
Colour	Black
Weight (Module Only)	2.04kg (4 lbs 8oz)
Overall Weight (Module & Gro-Pot™)	3.21kg (7 lbs 1.2oz)
Width	680mm (26.77")
Height	200mm (7.87")
Depth (Module Only)	220mm (8.66")
Overall Depth (Including Gro-Pot™)	375mm (14.76")
Maximum Loading	50kg (110 lbs 3.7oz) per module
Biological Resistance	Not affected by biological activity.
Recommended Service Temperature	-10°C to 70°C (14 °F to 158 °F)

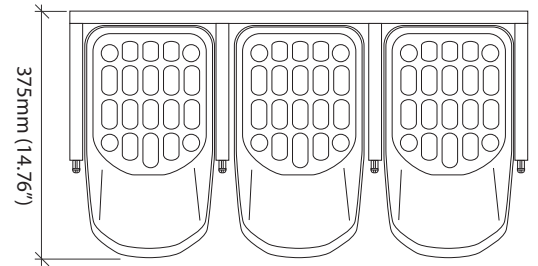
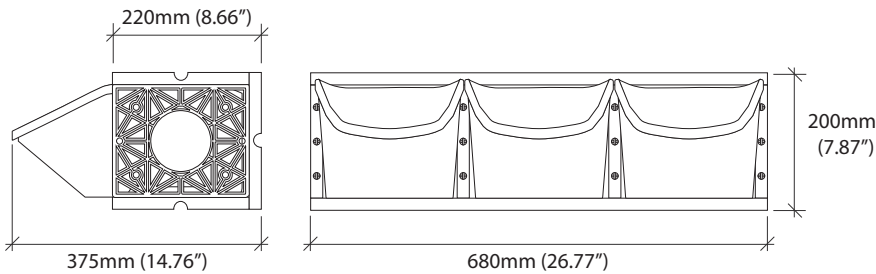
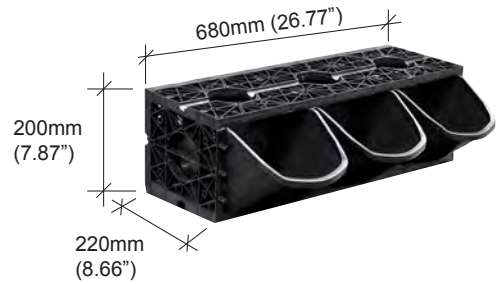

Gro-Wall® PRO Specifications (1 module)

Part Number	
Material	85% Recycled PP, 15% Propriety Materials
Colour	Black
Weight (Module Only)	1.820 kg (4.01 lbs)
Overall Weight (Empty Module & Gro-Pot™)	2.215 kg (4.88 lbs)
Width	480mm (18.9")
Height	270mm (10.6")
Depth (Module Only)	260mm (10.23")
Overall Depth (Including Gro-Pot™)	410 mm (16.1")
Biological Resistance	Not affected by biological activity.
Recommended Service Temperature	-10° C to 70° C (14° F to 158° F)

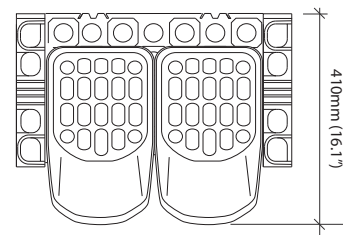
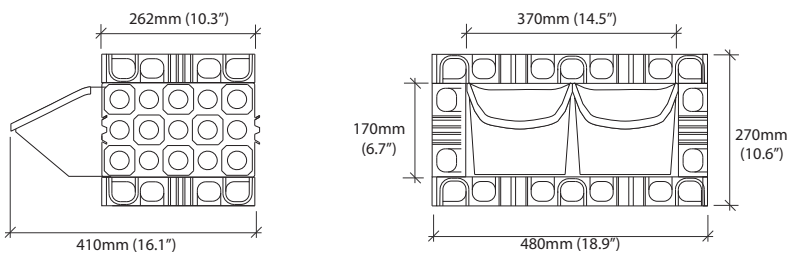
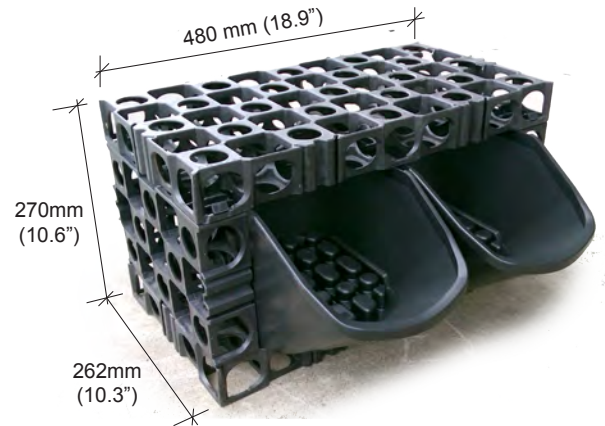

Flo-Log® Sub Surface Drainage Specifications

**Custom sizes available*

Standard Size Drainage Logs.

The logs are pre wrapped in quality geo-textile and are available in various sizes. The logs are two metres in length and can be connected together to form any length.

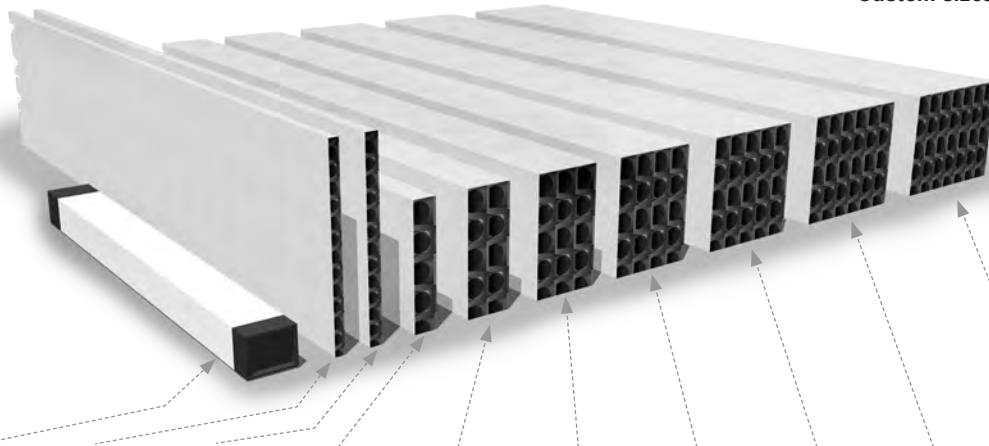

Part Number	30014	20418	10418	10519	10520	10521	10522	10523	10524	10525
Width	100 mm	20 mm	30 mm	52 mm	104 mm	156 mm	208 mm	260 mm	312 mm	364 mm
Height	80 mm	408 mm	408 mm	260 mm	260 mm	260 mm	260 mm	260 mm	260 mm	260 mm
Length	1080 mm	1920 mm	1920 mm	1920 mm	1920 mm	1920 mm	1920 mm	1920 mm	1920 mm	1920 mm
Horizontal Flow Rate @ 0.5% gradient (Approximate)	80 L/m	106 L/m	178 L/m	267 L/m	427 L/m	640 L/m	854 L/m	934 L/m	1120 L/m	1307 L/m
Weight	0.62 kg	2.4 kg	2.98 kg	2.6 kg	5.2 kg	7.8 kg	10.4 kg	13 kg	15.6 kg	18.2 kg
Geotextile	Hydrophillic Non Woven Geotextile (As per Atlantis Specifications)									
Void Ratio	90% void									
Material	85% Recycled PP, 15% Propriety Materials									
Biological Resistance	Not affected by biological activity									
Chemical Resistance	Excellent resistance to Urine, Acids, Alcohols, Bases and Mineral Oils. Good resistance to Aldehydes, Esters, Aliphatic Hydrocarbons, Ketones and Vegetable Oils.									
Service Temperature	-10°C to 70°C, (14° F to 158° F)									

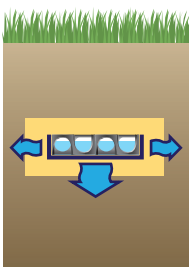

Flo-Log® Horizontal Exfiltration Area (Linear Metre)

Part Number	30014	20418	10418	10519	10520	10521	10522	10523	10524	10525
Gross Exfiltration Area	0.26 m ²	0.45 m ²	0.47 m ²	0.63 m ²	0.74 m ²	0.84 m ²	0.95 m ²	1.05 m ²	1.15 m ²	1.26 m ²
Net Exfiltration Area (90%)	0.23 m ²	0.40 m ²	0.42 m ²	0.57 m ²	0.67 m ²	0.76 m ²	0.85 m ²	0.94 m ²	1.03 m ²	1.13 m ²

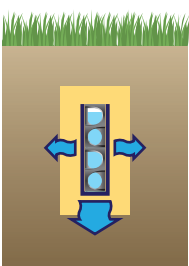

Flo-Log® Vertical Exfiltration Area (Linear Metre)

Part Number	30014	20418	10418	10519	10520	10521	10522	10523	10524	10525
Gross Exfiltration Area	0.28 m ²	0.84 m ²	0.85 m ²	0.57 m ²	0.62 m ²	0.68 m ²	0.73 m ²	0.78 m ²	0.83 m ²	0.88 m ²
Net Exfiltration Area (90%)	0.25 m ²	0.76 m ²	0.77 m ²	0.51 m ²	0.56 m ²	0.61 m ²	0.66 m ²	0.70 m ²	0.75 m ²	0.79 m ²

Flo-Wall® Vertical Drainage Specifications



Part Number	10412	10418	10424	11212	10519	30014
Width	400 mm (15.7")	400 mm (15.7")	400 mm (15.7")	1200 mm (47.2")	260 mm (10.2")	100 mm (3.93")
Height	1200 mm (47.2")	1800 mm (70.8")	2400 mm (94.5")	1200 mm (47.2")	1920 mm (75.6")	1080 mm (42.52")
Thickness	30 mm (1.18")	30 mm (1.18")	30 mm (1.18")	30 mm (1.18")	52 mm (2.04")	80 mm (3.14")
Weight	1.49 kg (3.28 lbs)	2.24 kg (4.93 lbs)	2.98 kg (6.56 lbs)	4.47 kg (9.85 lbs)	2.60 kg (5.73 lbs)	0.62 kg (1.36 lbs)
Flow Rate @ 0.5% gradient (Approximate)	178 L/m	178 L/m	178 L/m	533 L/m	267 L/m	80 L/m
Geotextile	Hydrophillic Non Woven Geotextile (As per Atlantis Specifications)					
Core Material	85% Recycled PP, 15% Propriety Materials					
Void Ratio	90% void					
Biological Resistance	Not affected by biological activity					
Chemical Resistance	Excellent resistance to, Acids, Alcohols, Bases and Mineral Oils. Good resistance to Aliphatic Hydrocarbons, Ketones and Vegetable Oils.					
Service Temperature	-10°C to 70°C, (14° F to 158° F)					



Atlantis Corporation Australia Pty Ltd

PHONE: + 612 9417 8344

FAX: + 612 9417 8311

EMAIL: info@atlantiscorp.com.au

WEB: www.atlantiscorp.com.au

Note: Atlantis products are manufactured from carefully selected high quality recycled materials. The strength of the recycled plastic could vary slightly due to raw material composition, country of manufacture, manufacturing process and external conditions. All trademarks are the property of Astral Property Pty Ltd.

Disclaimer: All information provided in this publication is correct to the best knowledge of the company and is given out in good faith. This information is intended only as a general guide, no responsibility can be accepted for any errors, omissions or incorrect assumption. As each project is unique, and as Atlantis Corporation Australia Pty Ltd and its distributors and agents world wide have no direct control over the methods employed by the user in specifying, installing or supervising of its products hence no responsibility is accepted by Atlantis Corporation Pty Ltd and its distributors and agents world wide. Users should satisfy themselves as to the suitability of the product for their purpose. All product designs, and specification are subject to change without further notice. All Atlantis products are tested in approved laboratories, and safe allowed tolerances should be practised in the actual field, to compensate for any unforeseen situations, on site and on products. All material contained within this brochure is subject to copyright, and belongs to Atlantis Corporation Australia Pty Ltd. No part of this brochure may be reproduced or transmitted in any form or by any means, electronic, mechanical, photocopying, recording or otherwise, without prior written permission of Atlantis Corporation Australia Pty Ltd. Copyright © 2016

Atlantis Vertical Garden Systems

Gro-Wall[®] Version 4.5

Gro-Wall[®] Slim Pro **NEW**

Gro-Wall[®] Slim Line **NEW**



Vertical Gardens

Vertical Gardens Made Easy!

Atlantis vertical garden systems facilitates installation of vertical gardens in adverse outdoor environmental conditions and in regulated indoor environments with complete access and control.

Our vertical gardens systems provide targeted watering control of individual plants, maximum water efficiency, last minute design changes and easy access to irrigation components.

Benefits

- Rapid Construction
- Quick Plant Installation
- Vertical & Horizontal Expansion
- Easy Creative Planting Design
- Self Supporting Structure
- No Framework Required
- Structurally Strong
- Modular Planting System
- Optimum Moisture Retention for Plants
- Easy Individual Plant Access & Maintenance
- Excess Water Capture System Available



Gro-Wall® 4 installed onto office, Croatia 2016.

Why Use Gro-Wall®



Water Efficient
Gro-Wall® is highly water efficient. The system can be tailored to water plants without excess runoff.



Modular System
Gro-Wall® is a modular system allowing easy vertical and horizontal expansion.



IPI™ System
Gro-Wall® features individual plant irrigation system.



Thermal Insulator
Gro-Wall® performs as a thermal insulator for buildings, cooling in summer and retaining heat in winter.



Recycled Materials
Gro-Wall® is made from high quality recycled materials.



IFS™ System
Integrated frame work system. Gro-Wall® is fixed directly onto the wall. No additional framework is required.



Sound Insulation
The Gro-Wall® 4 design is a highly effective sound insulator holding up to 140L of soil media per square metre.



Versatile Planting
Gro-Wall® 4 can accommodate a large variety of plant species including grasses, Sedums, Succulents.



Complete Access
Gro-Wall® allows complete & easy access to individual plants and irrigation components.



GRO-WALL® SLIM PRO

PROFFESIONAL SLIM VERTICAL GARDEN SYSTEM

The Gro-Wall® Slim Pro is a new vertical garden green wall system with a thinner profile making the system ideal for applications where space is limited.

The new features include built in drainage within the framework, planter tray locks automatically when inserted and the irrigation can now be mounted on the front of the unit as well as in the center of the unit. The new planter tray is thinner and allows for 6 litres of soil media ensuring healthy plant growth and moisture retention.

Plant to plant irrigation is beautifully balanced providing evenly distributed irrigation to the plant below. It is also now optional, and can be blocked off to allow the water to drain away to a drainage outlet with the use of irrigation pipes. This feature is ideal for indoor applications where drainage outlets are not available or for applications that require plants to be self contained so as to prevent plant disease spreading to other plants.

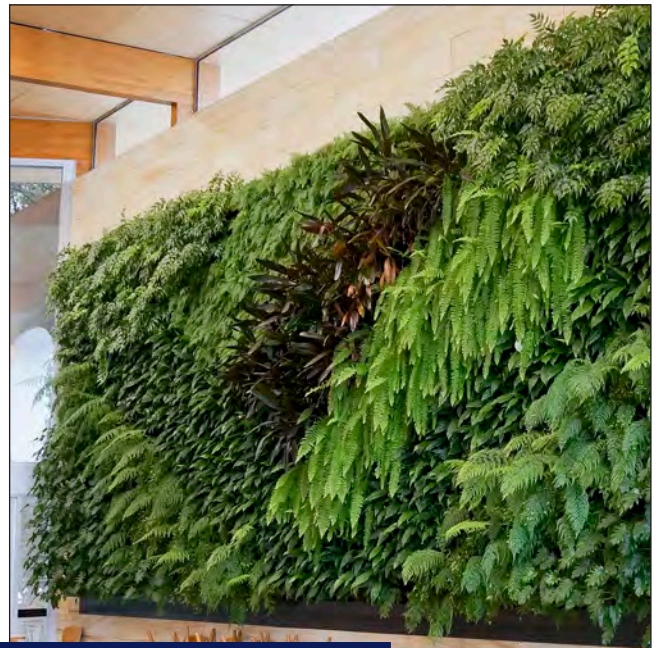

GRO-WALL® SLIM PRO

PART NUMBER: 80080

ASSEMBLED KIT DIMENSIONS

(W) 808mm (H) 704mm (D) 165mm

(W) 31.8" (H) 27.7" (D) 6.5"

Each kit includes 6 planter trays.



GRO-WALL® SLIM PRO AT A GLANCE

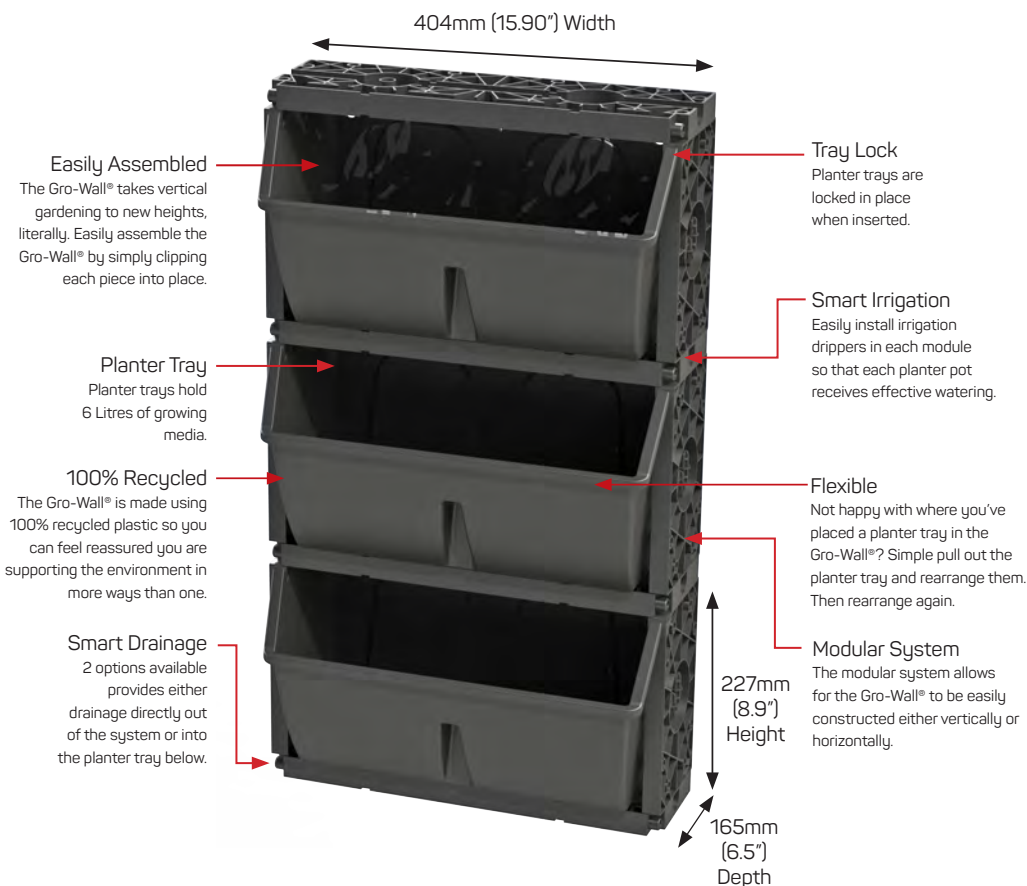

GRO-WALL® SLIM LINE

SLIM LINE VERTICAL GARDEN SYSTEM

The Gro-Wall® Slim Line is a new vertical garden green wall system that provides a thinner profile making the system ideal for applications where space is limited.

The new features include built in drainage sockets and irrigation locking clips. The new planter tray is thinner in depth and allows for 6 litres of soil media ensuring healthy plant growth and moisture retention.

Plant to plant irrigation is beautifully balanced providing evenly distributed irrigation to the plant below. The Planter tray features drainage sockets that can be connected to standard irrigation pipes for connection to a drainage locations on site. This feature is ideal for indoor applications where drainage outlets are not available near the green wall vertical garden installation.

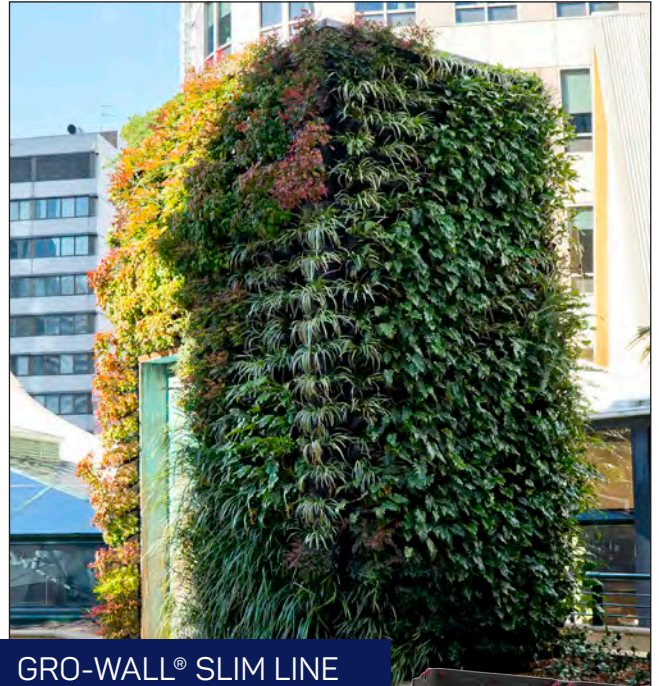

GRO-WALL® SLIM LINE

PART NUMBER: 80081

ASSEMBLED KIT DIMENSIONS

(W) 820mm (H) 682mm (D) 165mm

(W) 32.28" (H) 26.85" (D) 6.5"

Each kit includes 6 planter trays.



GRO-WALL® SLIM LINE AT A GLANCE

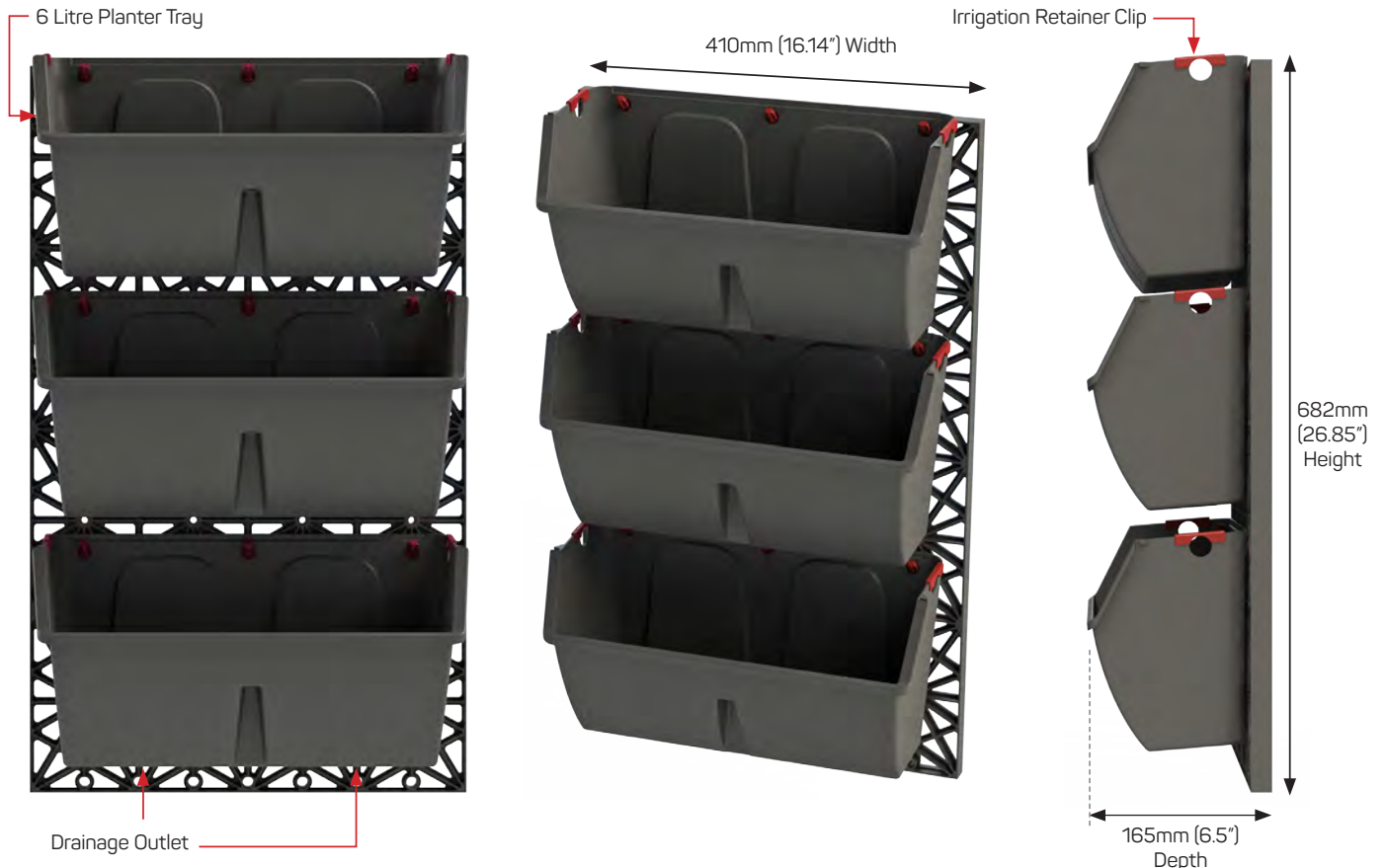

Gro-Wall® 4.5

NEW Gro-Wall® 4.5 Features Pot Locking.

Gro-Wall® 4.5 is the latest version of the well loved vertical garden system. This modular green wall product is an excellent solution where the priority is instantaneous beautiful aesthetics and minimal maintenance.

The system incorporates an integrated rigid framework that incorporates the conduits for individual plant irrigation.

The large pots accommodate 6.5 litres of soil media perfect for flourishing plant growth. The pot feature built in water reservoir and drainage for the excess water.

Easy Access

Gro-Wall® permits easy and complete access to both plants and irrigation components. This feature enables easy design changes and maintenance. Removal of individual plants and access to the irrigation components can be achieved in seconds.



Versatile Irrigation

Gro-Wall® 4.5 features IPI™ individual plant irrigation provision that allows conventional drip emitter and irrigation conduits to be installed within the Gro-Wall® framework. Each plant cell is irrigated directly via a drip emitter which is installed into the system.

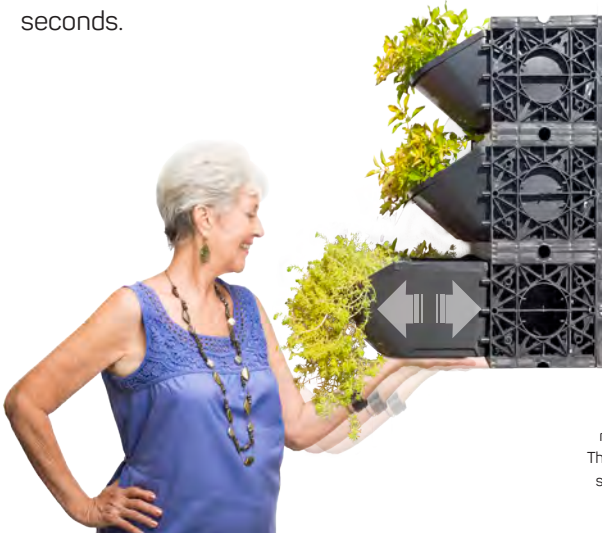
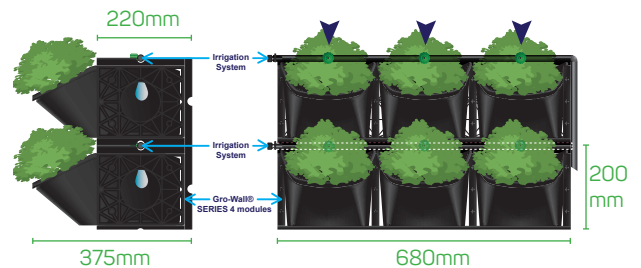

Pots are easily installed and removed in seconds.

GRO-WALL® 4.5
PART NUMBER: 80040

Gro-Wall® 4.5 at a Glance

- Smart Irrigation**
Easily install irrigation drippers in each module so that each planter pot receives effective watering. This means you don't have to soak the top row so that the bottom row receives water.
- Easily Assembled**
The Gro-Wall® takes vertical gardening to new heights, literally. Easily assemble the Gro-Wall® by simply clipping each piece into place.
- 100% Recycled**
The Gro-Wall® is made using 100% recycled plastic so you can feel reassured you are supporting the environment in more ways than one.
- Modular System**
The modular system allows for the Gro-Wall® to be easily constructed either vertically or horizontally.
- Flexible**
Not happy with where you've placed a plant in the Gro-Wall®? Simple pull out the planter pot and rearrange them. Then rearrange again.
- Planter Pots**
Each planter pot has the capacity to contain 6.5L of soil, more than enough for healthy plants. Pots can be locked in place using a locking pin.

Gro-Wall® 4.5 Module Size

A single Gro-Wall® module measures 680mm in width, 200mm in height and 220mm in depth. When the pot is inserted the depth increases to 375mm. A kit of Gro-Wall® includes 6 modules which measures 1200mm in height if the modules are stacked on top of each other.

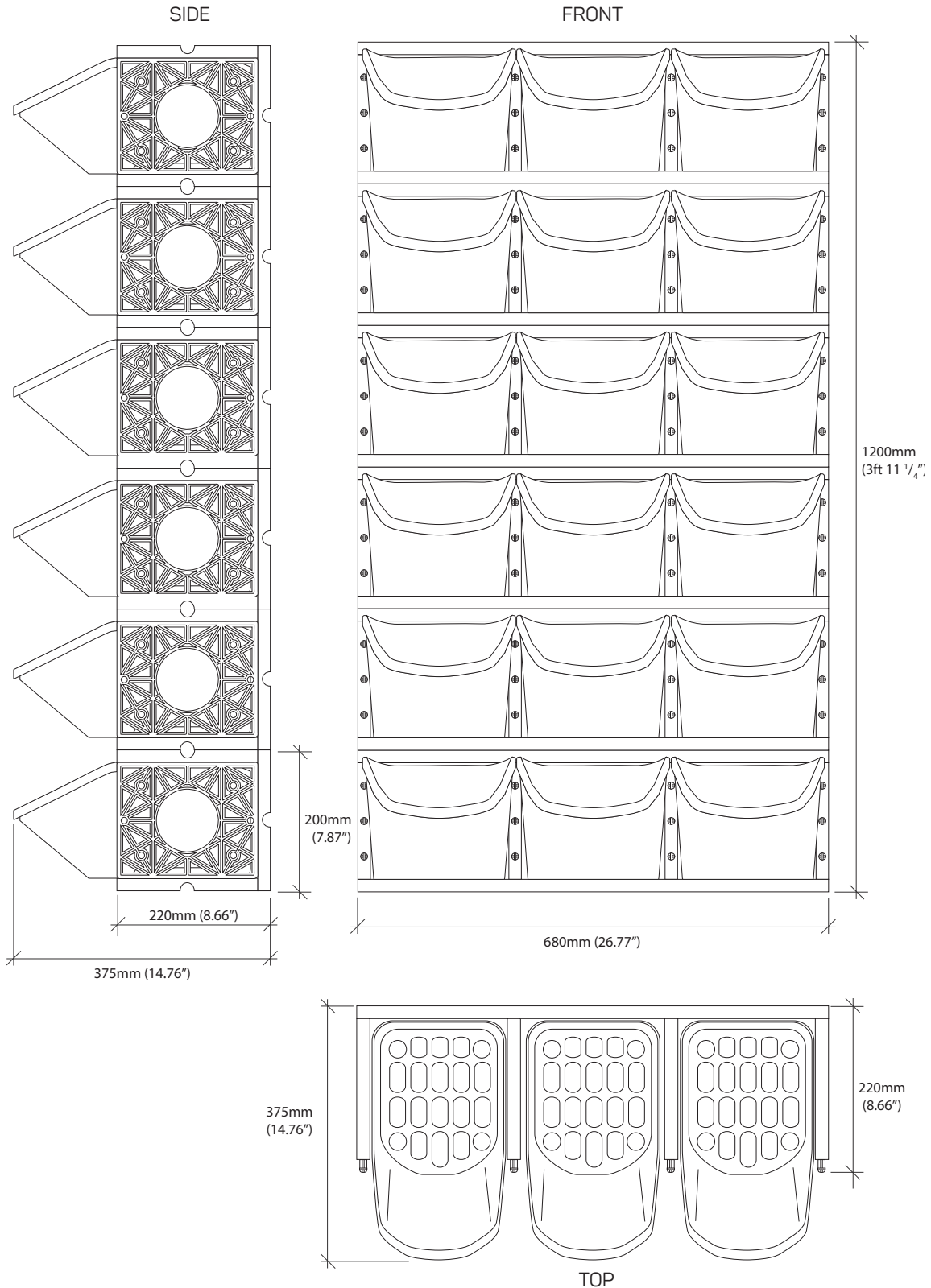

Gro-Wall®

VERTICAL GARDEN SYSTEM



Available From:



ATLANTIS CORPORATION AUSTRALIA PTY LTD
Phone: (02) 9417 8344
Fax: (02) 9417 8311
Email: info@atlantiscorp.com.au
Web: www.atlantiscorp.com.au

Note: Atlantis products are manufactured from carefully selected recycled materials that meet or exceed Atlantis material specifications and product performance requirements. The strength of the recycled plastic could vary due to raw material composition, country of manufacture, manufacturing process and external conditions. All trademarks and Patents are the property of Astral Property Pty Ltd.

Disclaimer: All information provided in this publication is correct to the best knowledge of the company and is given out in good faith. This information is intended only as a general guide, no responsibility can be accepted for any errors, omissions or incorrect assumption. As each project is unique, and as Atlantis Corporation Australia Pty Ltd and its distributors and agents world wide have no direct control over the methods employed by the user in specifying, installing or supervising of its products hence no responsibility is accepted by Atlantis Corporation Australia Pty Ltd and its distributors and agents world wide. Users should satisfy themselves as to the suitability of the product for their purpose. All product designs, and specification are subject to change without further notice. All Atlantis products are tested in approved laboratories, and adequate factors of safety should be practiced in the actual field, to compensate for any unforeseen situations, on site and on products. All material contained within this brochure is subject to copyright, and belongs to Atlantis Corporation Australia Pty Ltd. No part of this brochure may be reproduced or transmitted in any form or by any means, electronic, mechanical, photocopying, recording or otherwise, without prior written permission of Atlantis Corporation Australia Pty Ltd. Copyright @ 2017