



DAINTREE

EDL106 TC

Read this user guide carefully before installation, and keep for future reference.

INSTALLATION GUIDE

- ▲ The installation and maintenance work should be performed by a qualified electrician.
- ▲ Isolate power before installation.
- ▲ Warranty void if product had been altered or tampered with.



This range of EDL106 LED products have been tested to **AS/NZS60598.2.2:2016** standards and are approved to the luminaire will not exceed 90°C when side abut or covered with ceiling insulation. Building insulation used to abut and cover the luminaire must meet the following requirements:

Be of a type that can maintain its dimensions and structural integrity when exposed to the maximum surface temperatures of the class of luminaire, being 90°C and must withstand a 30s needle flame test carried out in accordance with AS/NZS 60695.11.5 with the flame applied to all surfaces of the sample.

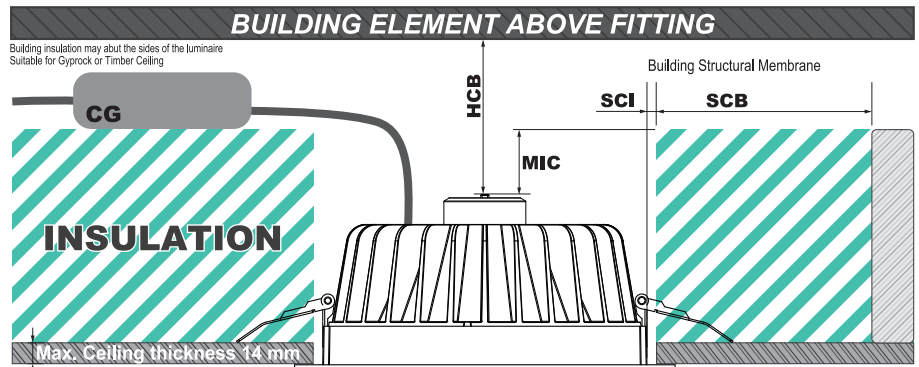
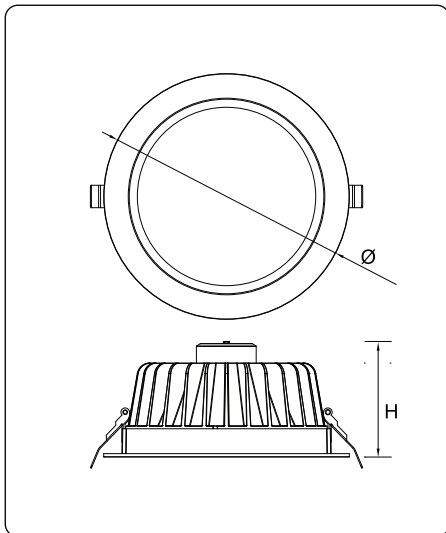

DIMENSION	CLEARANCE
HCB – The minimum clearance distance from the top of the luminaire to any normally flammable building element	0 mm
MIC – The minimum clearance distance from the top of the luminaire to any building insulation	0 mm
SCB – The minimum clearance distance from the side of the luminaire to any normally flammable building element	0 mm
SCI – The minimum clearance distance from the side of the luminaire to any building insulation	0 mm
SCG – Side clearance to auxiliary equipment control gear (CG)	NA

MODEL NO.	INPUT VOLTAGE (V)	POWER (W)	LUMEN (lm)	COLOUR TEMPERATURE (K)	BEAM ANGLE (°)	CRI	DIMENSIONS (Ø×H) (mm)	CUT OUT SIZE (Ø) (mm)	FITTING COLOUR
EDL106-3 TC WH	240	18	1550/1650/1700	3000/4000/6000	90	>80	162 X 82	145	White
EDL106-4 TC WH	240	25	2100/2250/2350	3000/4000/6000	90	>80	193 X 94	165	White
EDL106-5 TC WH	240	35	3000/3150/3300	3000/4000/6000	90	>80	230 X 106	200	White

WARRANTY

In accordance with **elekzon's** standard terms and conditions of sale, **elekzon** warrant this product to be free from defects in materials and or workmanship for a period as stated below for goods not subject to incorrect installation, maintenance, operation, mishandling, environmental, unauthorised modifications or electrical operating conditions outside the nominated product specification as detailed in these installation instructions. The benefits to you given by this warranty are in addition to other rights and remedies you have under law. Our goods come with guarantees that cannot be excluded under the Australian Consumer Law. You are entitled to a replacement or refund for a major failure and compensation for any other reasonably foreseeable loss or damage. You are also entitled to have the goods repaired or replaced if the goods fail to be of acceptable quality and the failure does not amount to a major failure.

Warranty term – Sixty(60) months from date of purchase.

NOTE:

elekzon encourages recycling, please consider the environment when disposing off packaging and components. As a guide for continual operation installations, a twelve (12) hour duration for Industrial and Commercial applications and six (6) hour duration for Residential applications should be considered.

