

**HOBART**

**WAREWASHING  
GLASSWASHERS GCROI**



## PROFI GCROI

A smaller model for professional use in bars, restaurants and hotels. With a water consumption of just 1.9 litres this is the most economical glasswasher on the market. Rack size 400 x 400 mm, compact installation height of 705 mm.

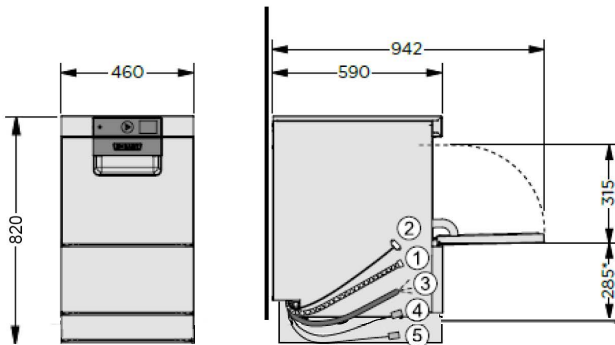

\* = + 40mm

CONNECTIONS	
① Drain hose	2,000 mm   ID20/OD25
② Supply hose	2,000 mm   R 3/4"
Required flow rate	5 l/min
Flow pressure	0.5 (0.8 with softener) - 6 bar
Max. supply water temperature	35 °C
③ Power cord	2,000 mm
Supply hose for	
④ Detergent	2,500 mm
⑤ Rinse aid	2,500 mm

TECHNICAL DATA	
Cycle times*	75 / 120 sec
Water consumption	1.9 l/rack
Tank capacity	8 l
Tank heating	0.8 kW
Power supply	415 / 50 / 3N (240 / 50 / 1)

BOOSTER LOADING	
Standard	2.8 kW
Alternative	4.2 kW

TOTAL LOADING	
Standard	3.2 kW   15A
Alternative	5.4 kW   15 A (3ph)
Wash pump	0.6 kW   220 l/min
Rack size	400 x 400 mm
Loading height	315 mm
Noise level	62 dB (A)
Weight (gross / net)	64 / 58 kg

## PRODUCT ADVANTAGES

- **Compact glasswasher:** with an installation height of only 705 mm ideal for narrow places or with integrated reverse osmosis and an installation height of 820 mm ideal for undercounter installation
- **VISIOTRONIC-TOUCH control:** colour touch screen (displays text and graphic) in conjunction with single-button control and remaining cycle time indication.
- **WASHSMART app:** controlling your warewash operation with smart technology: status and messages, usage and operating costs, hygiene, service and consumables order
- **1.9 l rinsing:** water consumption per cycle of only 1.9 l which results in a reduction of water, chemicals and energy consumption of 35 %
- **CLIP-IN wash and rinse arms:** wash and rinse arms can be removed with one hand and without any tools
- **Intelligent data documentation:** automatic recording of important operational data and consumptions and indication on the display
- **USB-interface:** comfortable download of operational data in form of a protocol via USB
- **GENIUS-X<sup>2</sup> fine filter system:** advanced filter system with pre-wash function reduces detergent consumption up to 35%
- **Cold rinsing:** the rinse can be switched from hot to cold water so that you get cooler glasses without any loss of time
- **Intensive programme:** intensive rinse cycle to wash glasses with critical design with raised fresh-water amount
- **Interlocked strainer:** prevents operation without tank strainer
- **Optional refill signal:** monitors contents of external as well as integrated chemical containers
- **Hygiene programme:** for removal of calcium carbonate and other deposits from wash chamber
- **WATERMARK approve**

\* Thermostat guarantees required temperatures with cold water and / or 230 V connection, the actual cycle times extend accordingly. For machine protection the water hardness should not exceed 3°dH, if higher we recommend using an integrated water softener or an external water softener of the product line HYDROLINE PROTECT. To avoid spots and streaks on the wash ware, we recommend the usage of an demineralisation cartridge (HYDROLINE STAR / STAR EXTRA) or a reverse osmosis system HYDROLINE PURE.