

HOBART

WAREWASHING

HOOD-TYPE DISHWASHER AMXT



PROFI AMXT

The **PROFI** double rack machine for simultaneous washing of two glass and chinaware racks.

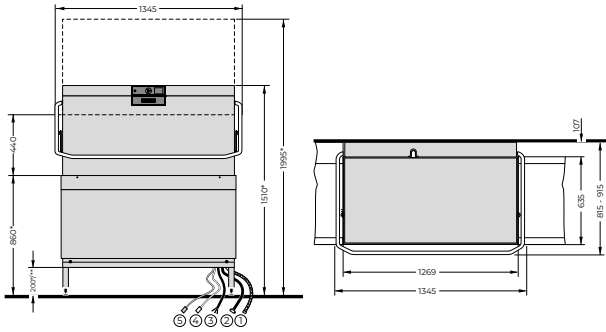

CONNECTIONS	
① Drain hose	2,000 mm ID 20 / OD 25
② Supply hose	2,000 mm R 3/4"
Required flow rate	5 l/min
Flow pressure	0.5 bar - 6 bar
Max. supply water temperature	60 °C
③ Power cord	2,500 mm
Supply hose for	
④ Detergent	2,000 mm
⑤ Rinse aid	2,000 mm

TECHNICAL DATA	
Cycle times*	60 / 90 / 180 sec. and special cycles
Water consumption	2 l/rack
Tank capacity	40 l
Tank heating	3.3 kW
Power supply	415 / 50 / 3N
BOOSTER LOADING	
Standard	12.4 kW
Alternative	6.2 kW
TOTAL LOADING	
Standard	16.7 3 x 32 A
Alternative	10.5 3 x 20 A
Wash pump	2 x 0.7 kW
Rack size	500 x 500 mm
Loading height	440 mm
Noise level	68 dB (A)
Weight (gross / net)	212 / 180 kg

* Thermostop guarantees required temperatures with cold water, the actual cycle times extend accordingly. For corner operation we recommend to make the right side of the machine accessible for service. For machine protection the water hardness should not exceed 3°dH, if higher we recommend using an integrated water softener or a HOBART HYDROLINE water treatment system.

PRODUCT ADVANTAGES

- **VISIOTRONIC-TOUCH control:** colour touchscreen (displays text and graphic) in conjunction with single-button control and remaining cycle time indication
- **WASHSMART app:** controlling your warewash operation with smart technology: status and messages, usage and operating costs, hygiene, service and consumables order
- **Double capacity:** the double wide wash chamber can cover 2 racks or bigger containers
- **SENSO-ACTIVE resource management:** constantly measures the quality of the wash water and keeps the amount of rinsing needed in each rinse cycle to the minimum in order to guarantee a fully hygienic wash result
- **Exhaust energy storage:** the fully enclosed 4-sided hood keeps steam and energy inside the system: energy saving up to 6 kW; less humidity in the kitchen area and better hygienic conditions
- **CLIP-IN wash and rinse arms:** wash and rinse arms can be removed with one hand and without any tools
- **GENIUS-X² fine filter system:** advanced filter system with pre-wash function reduces detergent consumption up to 35 %
- **VAPOSTOP (optional):** prevents vapour escaping from the machine when the hood is opened
- **Interlocked strainer:** prevents operation without tank strainer
- **Optional refill signal:** monitors contents of external chemical containers
- **EASY-CLEAN concept:** blue markings in the machine help the operator to identify the components which require cleaning
- **Thermolabel 71 °C:** default temperatures setting acc. European DIN can be switched by operator to a higher thermolabile setting