

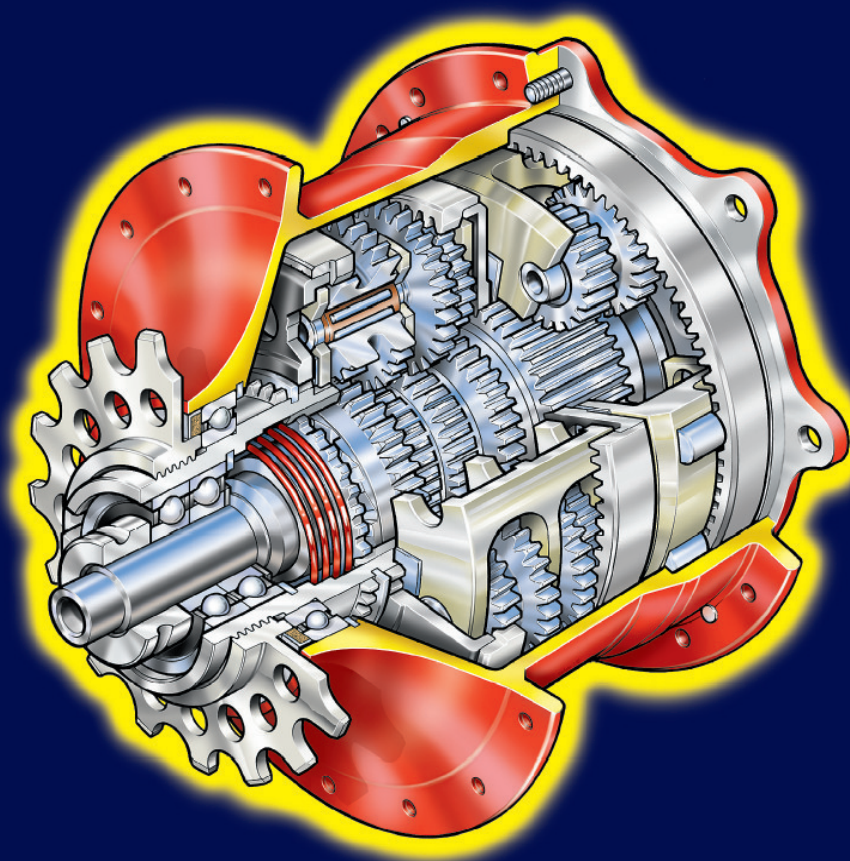

Version 2017_02

english



Germany:

Rohloff AG

Mönchswiese 11, D-34233 Fulda / Germany

Tel. +49 (0)561 - 510 80 0, Fax +49 (0)561 - 510 80 15

www.rohloff.de

Contact details for all Rohloff distributors can be found at:

www.rohloff.de/en/contact/rohloff_world_wide

SPEEDHUB 500/14



"Quicker than the surf"

France 1994. The atmosphere at the "Tour de France" was exhilarating and working with the teams and mechanics was exciting too. Our *Rohloff S-L-T 99* chain has proven a success with its reliability! So at last, a couple of quiet days on the Atlantic coast. Why not take the Mountain bike on the beach?! Crazy idea, yes! Riding exactly where the surf runs out! After just 200m, total stand still! The rear wheel is stuck fast in the wet sand. Changing the gears impossible! Derailleur gears won't work when you are stuck! The next wave came and both rider and bike received the first salt-water shower. Chain and sprockets are grinding full of fine sand. The next wave came - now nothing works. The waves were rolling in faster than we could change gears.

Still, it must feel great to have the waves roll out under the bottom-bracket. This idea didn't let go of me.

The lights were now burning bright and late into the night. The construction department in the Rohloff Company was working overtime. Successful gear changes and sprocket combinations were investigated. Mountainbike, downhill, touring and everyday riders were asked along with sports physicians: How many gears do you need and what has a gear hub got to be capable of in order to achieve maximum riding fun? 1997: finally we had our answer and put it to the test! Guess where...

The rear wheel is stuck fast in the wet sand. The first wave is coming. Change the gears down while stuck. 1st gear, gentle on the pedals, riding further - 2nd - 3rd - 4th... These gears are quicker than the surf!

30km of beautiful sandy beach lay ahead of us. It is a great feeling to have the waves roll out under the bottom bracket!

Bernhard Rohloff



This Owners Manual is also available in a variety of other languages. Should you require a different version, you can download it from our homepage under:

www.rohloff.de > Service > Downloads > Documentation

The following languages are available:

- English
- German
- Dutch
- French
- Italian
- Russian



TIP



- Owners Manual - Newest version
- Videos

The newest version of this Manual is available on the web under:
www.rohloff.de > service > downloads > documentation > owners manual

Further to the manual, the most important work, service and repairs on the *Rohloff* SPEEDHUB 500/14 are shown in short films on the web.
www.rohloff.de > Technology > Workshop > Videos ...



Owners Manual

General Use
Technical Information

Mounting

Service

Repairs

Appendix





Introduction

With the Rohloff SPEEDHUB 500/14 in the fast lane 1

Riding with the Rohloff SPEEDHUB 500/14

Safety information 3
Changing gears 5
Riding noises 6
Break in period 6
Pushing the bike 6
Wearable parts 6
Maintenance and care 7
Transport/Info for the tour 9
Wheel removal 11
Wheel installation 14

Technical data

Technical data 17
Weight comparison/Comparison of mechanical efficiency 18
Sprocket ratios 19
Smallest permitted sprocket ratios 19
Table of distance travelled per crank revolution (20", 26", 28" & 29") 20
Derailleur gears in comparison to Rohloff SPEEDHUB 500/14 21
Rohloff SPEEDHUB 500/14 in comparison to derailleur gears 22

Securing to the frame

Modular parts system 23
Axle types 24
Torque anchoring 25
Frame types/Drop outs..... 27
Mounting requirements OEM2 30

Cable routing

Internal gear mech 31
External gear mech 32



Rohloff SPEEDHUB 500/14 versions

Explaining the model codes 33
Rohloff SPEEDHUB 500/14 with disc brake 37
Advantages of the separate options 38
Model variations 39

The wheel

Wheel stability 41
Spoke lengths 42
Calculating the spoke length 43
Determining the inner rim diameter 44

Particular components

Which components are recommended? 45

Special applications

Particulars 47

All mounting processes

Contents 49

Maintenance of the Rohloff SPEEDHUB 500/14

Contents 86

Important service procedures

Contents 96

Appendix

Trouble shooting 119
Bolt/tool info (tightening torques)..... 124
Wheel lacing for rims with a European / French spoke hole patter 125-126
Technical Data / Pointers on the Serial No. 127-128
Grub screw of the External Gear Mech 129
The correct spoke choice / Possible causes for flange breakages on bicycle hubs 130-132
Flange Support Rings 134
Twistshifter light (right Art.No. 8206 - left Art.No. 8207)..... 135-142
Splined Sprocket System/ Splined Carrier 143-144
Monkey Bone (IS-PM Adapter) 145-146
PM Bone - PM Axleplate (PM-PM Adapter) 147-148
Notes..... 149-152
Index 153-154





Rohloff SPEEDHUB 500/14 CC DB OEM mounted in a frame with adjustable Rohloff OEM dropouts

Warranty of the Rohloff SPEEDHUB 500/14

Each Rohloff SPEEDHUB 500/14 has an individual Serial Number. This can be found printed either on the hub shell sticker (<~ number 74770) or engraved into the hub shell (>~ number. 74771).

ATTENTION

All entitlements to a guarantee are deleted if this serial No. Can not be produced. Warranty claims can only be processed if the guarantee card can be presented with the hub. Further information on the guarantee card can be found in the appendix under "Pointers on the Serial No."

To help us keep tabs on theft, it is advisable to register the Serial No. With us by way of the guarantee card.

A more precise explanation of the guarantee conditions can be found on the guarantee card itself which is included with every Rohloff SPEEDHUB 500/14 purchased.

With the Rohloff SPEEDHUB 500/14 in the fast lane

This handbook covers everything of interest about the Rohloff SPEEDHUB 500/14. It contains important information over the use, the component choice, the mounting, the service and the repairs. Should you still have any questions or queries after reading this handbook than please contact your local dealer or visit us on the web under www.rohloff.de.

Due to us constantly improving our products, the shape of the parts or the contents of the package may vary from those illustrated in this handbook. We kindly ask you to show some consideration.

The first chapter

Riding with the Rohloff SPEEDHUB 500/14

you will find everything you need to know about riding with the Rohloff SPEEDHUB 500/14.

In the following sections

- **Technical data**
- **Securing to the frame**
- **Shifter cable routing**
- **Rohloff SPEEDHUB 500/14 variations**
- **The wheel**
- **Which components are recommended**
- **Special applications**

you will find all the technical information needed to select the correct version of the Rohloff SPEEDHUB 500/14 for your needs.

In the chapters

- **Mounting**
- **Service**
- **Repairs**

you will find all the technical information needed for the mounting and service of the Rohloff SPEEDHUB 500/14.

Please read the important safety information carefully.

Every bicycle equipped with a Rohloff SPEEDHUB 500/14 should come complete with the following:

- A guarantee card (with dealers stamp and Serial Number).
- An owners Manual for the Rohloff SPEEDHUB 500/14.
- An oil filling tube.

Please read the important safety information before riding off!

Safety information

Bike riding is fun but it is also tied up with dangers. When your bike is not regularly maintained and kept in good condition, these dangers increase. These dangers, however, can be prevented when you read this handbook and the following safety information carefully. A incorrect fitment of the vital components could result in a crash, with possible life threatening injuries.

Mounting

- We recommend all fitting and assembly of our products should be carried out by a professionally qualified workshop.
- Improper work and customizing may result in malfunction and this in turn could lead to accidents occurring.
- Please make sure that you have the correct *Rohloff SPEEDHUB 500/14* model for your type of bike frame.
- All the bolts must be secured to the given tightening torques.
- The smallest permitted sprocket ratio must not be undercut.
- If a chain tensioner is in use at the rear, a chain guide must be used in conjunction up front to prevent the chain from springing off the chainring.
- On rear suspension frames the chain must be kept at a suitable length that allows the rear triangle to move the full amount of shock travel.
- When filling the *Rohloff SPEEDHUB 500/14* with oil for the first time as well as when changing the oil, make sure you use only *Rohloff SPEEDHUB* oils as recommended for the *Rohloff SPEEDHUB 500/14*.

Usage

Before riding with your *Rohloff SPEEDHUB 500/14* please follow the next few steps in order to truly trust the products service.

- Let your bike be regularly checked by a specialist workshop to make sure that it functions safely.
- When starting off, especially after a gear change, you must check the gear has engaged properly.
- Make sure you carry out the safety checks on all the other mounted components of your bike.
- Before a long journey or tour, a test ride must be taken. Through this process any mounting mistakes or loss of functions can be noticed and corrected. Also see ‘**Transport/Info for the tour**’.
- When utilizing a bicycle equipped with a ‘**Gates Carbon Drive**’ belt transmission, it is important to adhere to the manufacturers instructions printed within their Owners Manual. Europe: www.carbondrive.net and US: www.gatescarbondrive.com
[Http://www.g-boxx.com/pdf/Gates-Rohloff-manual-en.pdf](http://www.g-boxx.com/pdf/Gates-Rohloff-manual-en.pdf)

- Cycling through deep water with a *SPEEDHUB* is not permitted. Do not submerge the *SPEEDHUB* as water will penetrate the gear-unit.
- Unprotected transportation on a motor vehicle through heavy rain can also lead to water penetration and should be avoided.
- An oil change should be completed immediately if you believe water may have penetrated the gear-unit. This will ensure any potentially penetrated moisture is rinsed back out.

Check regularly:

- That the *Rohloff SPEEDHUB 500/14* is correctly and securely mounted in the frame (quick release axle max. 7Nm or threaded axle max. 35Nm).
- That all hub cap screws are correctly tightened, especially on *DB* versions of the *Rohloff SPEEDHUB 500/14* that incorporate the use of a brake disc.
- That the hubs torque securing system is correctly fastened to the frame.
- That the brake surfaces are free from oil and grease.
- That the shifter cables and connectors are correctly and securely connected (bayonet connectors or external gear mech).
- That the parts on your bike are not damaged or failing to function properly as the result of an accident. The use of damaged parts can result in further accidents occurring.



Rohloff SPEEDHUB 500/14 CC DB OEM mounted in a frame with adjustable *Rohloff* OEM dropouts

Changing gears

All 14 gears of the *Rohloff SPEEDHUB 500/14* are selectable through one twist shifter, so that in one turn it is possible to change up or down by one or more gears.

The mark on the twist shifter casing next to the gear numbers informs the user of which gear has been selected. The assembly instructions show the twist shifter being fitted to the right hand side of the handlebars, however, in special circumstances it is possible to fit the twist shifter to the left hand side. When rotating the twist shifter in the direction of #14, a harder, faster gear is selected. When rotating the twist shifter in the direction of #1, an easier, slower gear is selected.

In contrast to other gear systems on the market, with the *Rohloff SPEEDHUB 500/14* there is no delay between gear selection on the twist shifter and gear change in the hub. The moment the notch can be felt in the twist shifter, the gear has been changed. Therefore a quick and failure free gear change is possible whilst riding and also when stationary.

When changing, gear coupling elements inside the hub must move and when there is more pressure on the pedals it is obvious there is more pressure on these coupling elements resulting in a harder gear change. Whilst stationary or when there is less pressure on the pedals, the twist shifter has less resistance and therefore a lighter gear change is possible. In a situation whereby it is not possible to reduce the pressure on the pedals (e.g. hill climbing), it is still possible to change gear quickly and smoothly. Simply change gear when the cranks are in a straight up-down position where hardly any pressure is being applied upon the pedals.

ATTENTION

Changing gear with the *Rohloff SPEEDHUB 500/14* with pressure on the pedals is not necessary when being used appropriately. However due to the robust construction of the *Rohloff SPEEDHUB 500/14* changing gear under pressure is possible and is not harmful to the hub. It is however possible that when changing gears under high pressure the hub could accidentally fall into a neutral gear, this is due to the coupling elements not seating correctly into the next elements and therefore rebounding back. If this occurs the rider could lose balance and crash. Changing gears under high pressure is at the riders own risk.

Particulars:

If changing up and down slowly or under high pressure between the gears #7 and #8, it is possible to fall momentarily into gear #11 or #14.



Riding noises

One of two different riding noises could be heard depending upon which gear is selected. A construction characteristic produces a freewheeling noise which is can be heard in most gears - particularly noticeable in gears #5, #6 & #7. A higher frequency is produced when riding with a higher force upon the pedals. This causes the volume of the lower gears to increase towards gear #7 - a typical characteristic of straight-toothed precision gears.

Different frame designs can amplify or deaden these audible noises because the tubes of the frames react as a resonator for the sound waves. Larger diameter tubes offer more room for sound waves thus the noise is amplified. Different noises are noticeable whilst freewheeling depending on which gear is currently selected. This is due to different elements of the gear mechanism rotating within the hub.

Break in period

All the gears and coupling elements of the *Rohloff SPEEDHUB 500/14* are built from specially hardened steel and are precision finished. In the first 1000km use, the *Rohloff SPEEDHUB 500/14* loses microscopic particles from all functioning components as part of the hubs last fine filing. After this process is completed the riding noises quieten and the changing of gears becomes easier. During this process it is not necessary to take extra special care.

Pushing the bike

Should the bike be pushed, it is possible that the cranks could also start to turn. This occurs due to the hub seal automatically activating the sprocket. Bad seals and a very light running bottom bracket make it easier for the cranks to turn. A drop of *Rohloff cleaning oil* (Art. #8402) through the holes in the sprocket onto the hub seal will reduce this activating effect.

Wearable parts

The wearable parts are: The sprocket, chainring, jockey wheels on the chain tensioner, twist shifter rubber grip, shifter cables and the brake disc. How quick the parts wear is down to how the product is used and cared for (pressure, dirt, weather and care). To guarantee the safe function, these parts must be replaced as soon as they are no longer capable of performing correctly. Let the workings of your bike be regularly checked over by a professional bike workshop.



Maintenance and care

The gears of the Rohloff SPEEDHUB 500/14 are protected from dust and harmful moisture due to running in an oil bath. The maintenance and care of the Rohloff system is limited to the following points:

- Chain and chain tensioner (where applicable) should in regard to regular use (at the latest after riding in rain) be cleaned and re-lubricated.
- The cable box of the external gear mech should be demounted approx. every 500km, cleaned and the cable pulley lightly greased from the hub-facing side.
- The shifter cable tension should be regularly checked, and when necessary altered by the cable adjusters.
- The Rohloff shifter cables are made from high-quality stainless steel and run in a nylon lined steel, spiral-wound cable housing which is protected at each end with a sealed ferrule. The cables are routed lubricant free and must not be greased or oiled. The stainless steel/nylon combination runs service-free.

Changing the oil in the Rohloff SPEEDHUB 500/14:

The Rohloff SPEEDHUB 500/14 is filled with 25ml of Rohloff SPEEDHUB OIL. This exact amount of oil is optimum for both the bearings and gears of the Rohloff SPEEDHUB 500/14. The oil must be changed at least once a year or every 5000km. This process enables us to ensure any lost oil is replaced and any penetrated moisture is rinsed back out (see chapter 'Service', paragraph 1. 'Oil change').

Cleaning the Rohloff SPEEDHUB 500/14:

Use only un-pressurized water and gentle cleaning fluids. Do not use a high power jet wash system, brushes or abrasive materials for cleaning purposes.

ATTENTION

Water may pass under the SPEEDHUB seals when using a high pressure wash system, steam cleaner, transporting the bicycle on a car through heavy rain or submerging the rear wheel. For this reason, these situations should be avoided. If not avoidable, we recommend that an oil change is performed immediately after so as to ensure any potentially penetrated moisture is rinsed back out of the SPEEDHUB before it can do any damage.

Maintenance and care

The shifter cable tension can be altered by the cable adjusters. Winding the cable adjusters out increases cable tension. **For the lightest possible gear change, the tension should be just enough that on the twist shifter there is approx. 2mm rotational play when in a selected gear.** The mark on the twist shifter body can be aligned to the correct gear number without altering the cable tension by winding one cable adjuster in and the other out.

ATTENTION

amount of friction within the shifter cables and in turn raises the force needed on the twist shifter to select other gears.

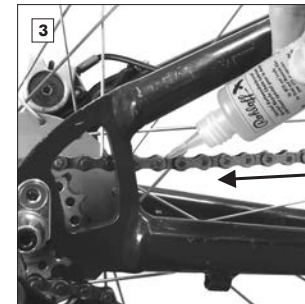

When lubricating the chain place a thin thread of lubricant on the outside of the chain over the centre rollers, this process is carried out quicker and easier when running the chain backwards whilst applying the lubricant.

ATTENTION

When using a disc brake in conjunction with the Rohloff SPEEDHUB 500/14, the hub cap screws should be checked that they are correctly tightened before every ride. To reduce the chance of a flange breaking due to unequal spoke tension, we recommend that this is regularly checked by a professional bicycle mechanic.

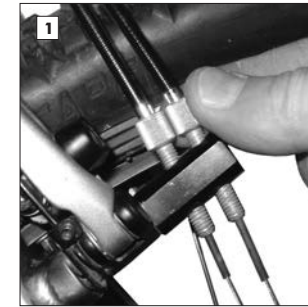

On the versions with an internal gear mech the cable adjusters are to be found on the cable guide. This can be found on the left hand chain stay or attached to the left hand brake boss of the frame.

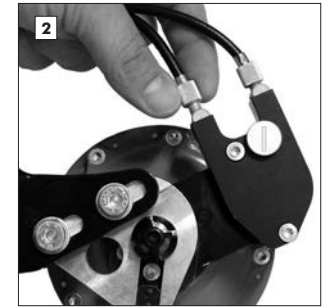

On the versions with an external gear mech the cable adjusters are to be found on the cable box which sits directly on the left hand side of the Rohloff SPEEDHUB 500/14.

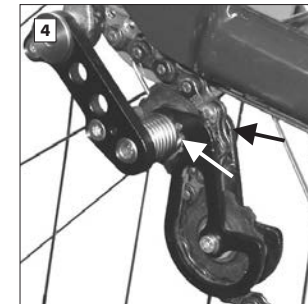

To lubricate the chain tensioner place a drop of oil on the left and right side of the upper jockey wheel on the pivot point.

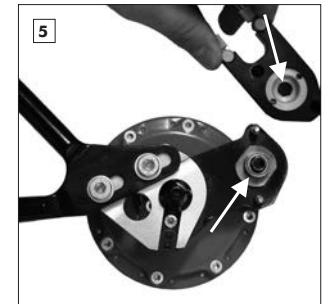

Rohloff SPEEDHUB 500/14 versions with external gear mech: To lubricate the cable pulley bearing remove the cable box and place a little grease on the parts arrowed in the diagram above.

Transportation

If transporting a bike fitted with a Rohloff SPEEDHUB 500/14, care should be taken that the rear wheel is transported in an upright position. In a car or an aeroplane, there could be great changes in the air temperature/pressure. When the wheel lies on its side, oil could seep out of the seals because the oil is sitting directly over these seals on either the left or the right side. Transportation in the upright position will prevent the air temperature/pressure in having an effect over the Rohloff SPEEDHUB 500/14. If it is not possible to transport the wheel in the upright position due to according packaging requirements, don't worry. The leakage of oil will not cause any damage.

Info for the tour

The Rohloff SPEEDHUB 500/14 immediately proved itself the optimum gear system, especially for tours and long journeys due to its durability, long life and the strength of the final wheel itself. Of course, good materials should always be used, so that the other parts on the bike start out not ruined, dirty, over lubricated, worn, so that their function is impaired or even damaged. Therefore, we suggest that in regard to poor parts on the bike you should always carry a few important tools with you. Our service team is on the net and you can Email us at service@rohloff.de. We endeavor to help with any technical problems and, when necessary, ship spare parts out all over the world. However, due to extremely high postage costs or lack of service in some countries, this is not always possible. You should therefore take consider carrying selected spare parts (in case of accident damage or excessive wear), a range of tools and this Owners Manual along for the tour. Owners manual also available online here: <http://www.rohloff.de/en/service/downloads/documentation/index.html>

Tools for on the go:

- 2mm allen key (male/female connectors, cable pulley screws)
- 2.5mm allen key (twist shifter securing screws)
- 3mm allen key (drain screw)
- 5mm allen key (securing bolts for torque arm/chain tensioner)
- 8mm wrench (for turning the shifting rod)
- 15mm wrench (for axle nuts where applicable)
- Chain lubricant and grease
- Torx TX20 (all other bolts of the Rohloff SPEEDHUB 500/14)

For long distance journeys the following should also be taken along:

- Oil change kit (Art. #8410)
- Sprocket tool (Art. #8501)
- Spare chain and sprocket, spokes and shifter cables
- Internal gear mech: spare hub cables (Art. #8271) or with a quick-change axle ring (after Serial Number 25300) Hub cable Easy Set (Art. #8573) or the complete axle ring set (Art. #8572)



Emergency repairs on the go

Several repairs can be improvised in emergency situations

Breaking of a hub cable (internal gear mech):

Remove axleplate and cable pulley, then use an 8mm wrench to select a suitable gear (e.g. gear #7). Riding further is now possible using this one gear.

Breaking of a shifter cable (internal gear mech):

Pull the hub cable until a suitable gear is found (e.g. gear #7). Riding further is now possible using this one gear.

Male or female connector lost or damaged (internal gear mech):

Join the hub cable and shifter cable together using an electrical terminal block.

Breaking of a shifter cable (external gear mech):

Remove the cable box and use an 8mm wrench select a suitable gear (e.g. gear #7). Riding further is now possible using this one gear.

Safety ring (and pin) of the quick release on the torque arm (where applicable):

Use an M6 nut and bolt or improvise by using binding wire.

Loss of oil:

Loss of oil through sweat oil or the light leakage of oil through the seals is harmless. Therefore, travelling further until the next scheduled oil change (every 5000kms or once per Annum) is not harmful to the gear-unit. See point 14 of 'oil leakage' in the appendix.

If you re experiencing any problems, please contact your nearest Rohloff agent: http://www.rohloff.de/en/company/contact/rohloff_world_wide/index.html



Wheel removal

To remove the rear wheel, please take note of the following steps:

1. Separate the gear mech 1.1 or 1.2
2. Loosen axle and where appropriate the torque arm 2.1 or 2.2
3. Removal of the wheel from the frame 3.1 and/or 3.2

1.1 Separating the internal gear mech:

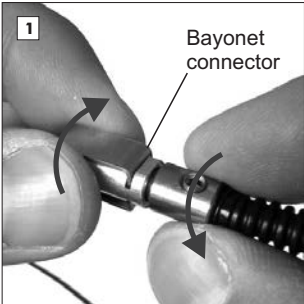

Separating the gear mech involves opening the bayonet connectors. To do this easily, select a middle gear, so that these connectors are in an easily reachable position. Next, to open the connectors, twist the male and female parts 90° in opposite directions whilst pulling them apart.

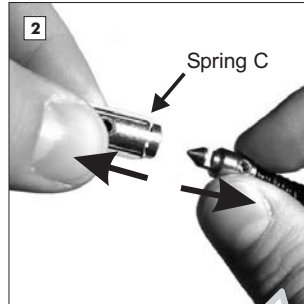

ATTENTION !

When opening the connectors, do not hold the female connector by the spring as this makes separating the connectors considerably more difficult.

1.2 Separating the external gear mech:

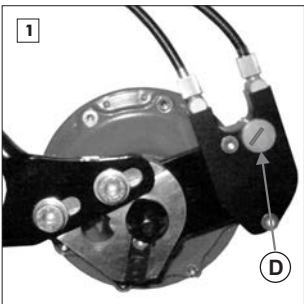

Separating the gear mech involves removing the cable box. Cable box sits over a hexagonal peg which joins it to the external transfer box. The wheel should be removed in gear #14 to make remounting the wheel easier. Loosen knurled head screw **D** and remove cable box **E**.

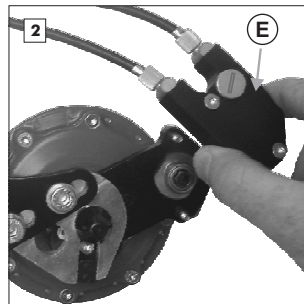

2. Loosening the torque support on versions with a long torque arm

2.1 CC versions

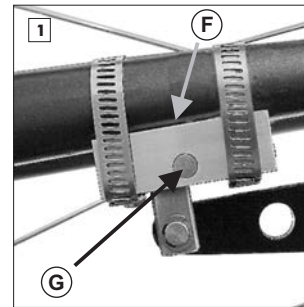

Open the quick release **F** by pushing the locking pin **G** from the inside of the frame in an outward direction away from the wheel.

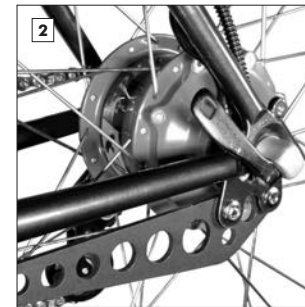

Open the axle quick release lever.

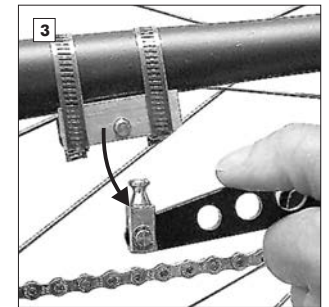

Pull the torque arm down in the direction of the arrow to release it from the frame.

2.2 TS versions

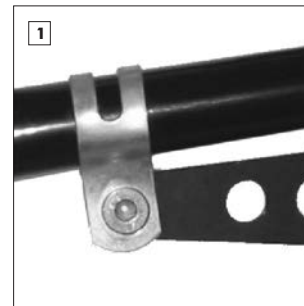

Loosen the torque arm clamp bolt by unscrewing it with a 4mm allen key.

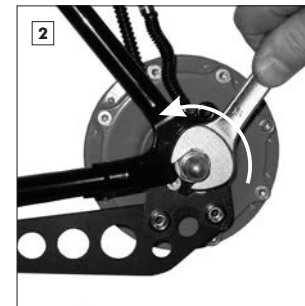

Loosen the axle nuts with a 15mm wrench.

3.1 Removal of the wheel from the frame

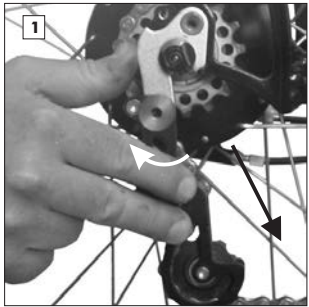

ATTENTION

A chain tensioner prevents the easy removal of the rear wheel (when mounted). The chain tensioner must be pulled backwards in the direction of the arrow to allow the sprocket to pass the chain tensioner. When, however, it is a DH chain tensioner, the mounting bolt must be loosened before the rear wheel can be removed.

Remove the wheel from the dropouts and the chain from the sprocket.

3.2 Wheel removal - OEM and OEM2 versions

No loosening of a torque arm is necessary with these versions. Simply open the quick release lever (CC versions) or loosen the axle nuts (TS versions).

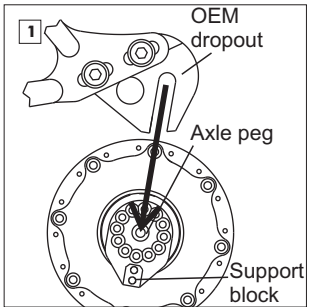

On the OEM versions, the axle and the support block are released together from the OEM dropout.

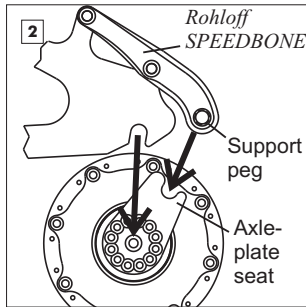

On the OEM2 versions with *Rohloff SPEEDBONE*, the axle falls out of the dropouts at the same time as the axle plate seat falls away from the *Rohloff SPEEDBONE* support peg.

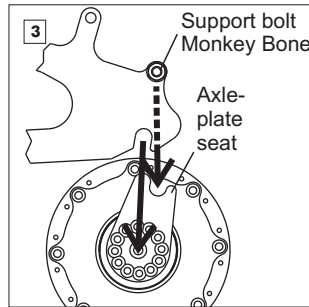

On the OEM2 versions with just a support bolt or Money Bone, the axle falls out the dropout at the same time as the axle plate seat falls away from the support bolt/Monkey Bone.

Wheel installation

Please take note of the following steps when mounting the wheel to the frame:

1. Installation of the wheel into the frame 1.1 and/or 1.2
2. Securing of the axle and, where appropriate, the torque arm 2.1 or 2.2
3. Joining of the gear mech 3.1 or 3.2

1.1 Wheel installation

Place the wheel into the dropouts, taking care that the chain is sitting properly on the sprocket and that the hub cables do not get clamped between the dropouts and the axle.

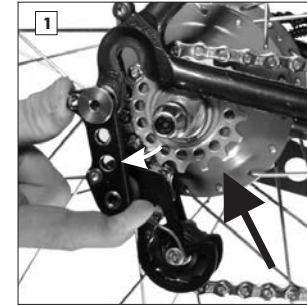

ATTENTION

A chain tensioner prevents the easy installation of the rear wheel (when mounted). The chain tensioner must be pulled backwards in the direction of the arrow to allow the sprocket to pass the chain tensioner. When, however, it is a DH chain tensioner, then the mounting bolt must be loosened before the rear wheel can be installed.

1.2 Wheel installation - OEM or OEM2 versions

On the OEM or OEM2 versions, the axle and the torque support are installed together.

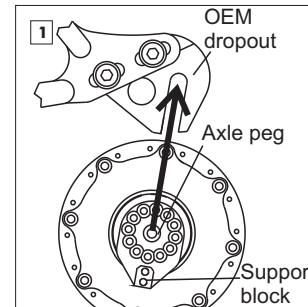

On the OEM versions, the axle must enter the long OEM dropout first, followed by the support block into the same slot.

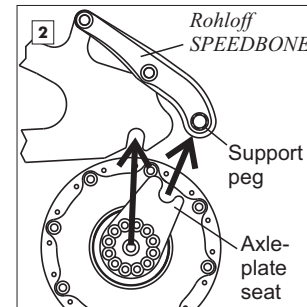

On the OEM2 versions with *Rohloff SPEEDBONE*, take care that the *Rohloff SPEEDBONE* support peg lines up with the axle plate seat as the axle is entered into the dropouts.

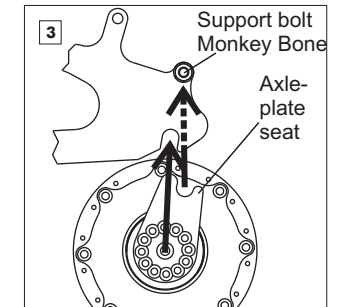

On the OEM2 versions with just a support bolt or Monkey Bone, take care that the support bolt or Monkey Bone lines up with the axle plate seat as the axle is entered into the dropouts.

After installing the wheel, close the quick release lever (CC versions - tightening torque: max. 7Nm/62in.lbs.) or tighten the axle nuts (TS versions - tightening torque: max. 35Nm/310in.lbs.).

ATTENTION

Before closing the quick release lever or tightening the axle nuts, check that both sides of the axle sit properly in the dropouts and that the wheel runs in the center of the frame.

2. Securing the long torque arm

2.1 CC versions

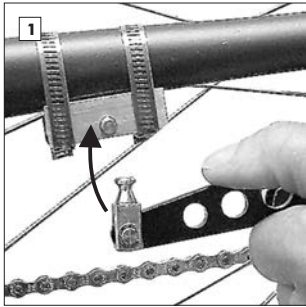

Swing the torque arm into the quick release block in the direction of the arrow shown.

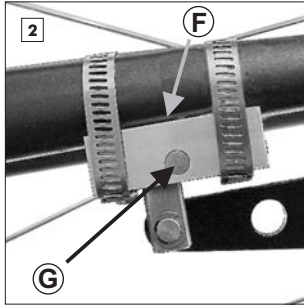

Close the quick release **F** by pushing the quick release pin **G** in the direction of the wheel, so that the outside of the pin is flush with the quick release block.

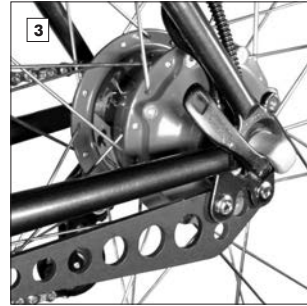

Close the quick release lever (max. 7Nm)

2.2 TS versions



Swing the torque arm in the direction of the securing clamp until it is possible to push the securing bolt through the holes of the clamp and the torque arm. Check that the axle is sitting properly in the dropouts.

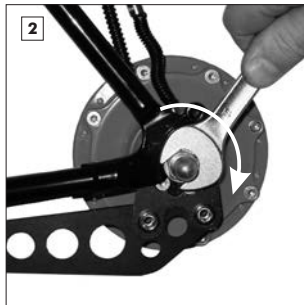

Tighten the axle nuts (tightening torque: 35Nm/310in.lbs.). With the nut and washer, tighten the torque arm securing bolt with 4mm allen key (tightening torque: 6Nm/51in.lbs.).

ATTENTION !

Before closing the quick release lever (max. 7Nm/62in.lbs.) or tightening the axle nuts (max. 35Nm/310 in.lbs.), check that both sides of the axle sit properly in the dropouts and that the wheel runs in the centre of the frame.

3.1 Joining together of the internal gear mech:

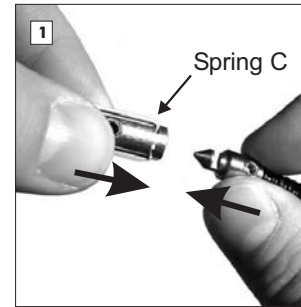

To rejoin the gear mech, the male and female bayonet connectors must be joined back together. Pay attention not to cross these cables over when joining the hub and shifter cables together. Push the male connector into the female connector until the spring locks them together. Take care not to hold the female connector by the spring.

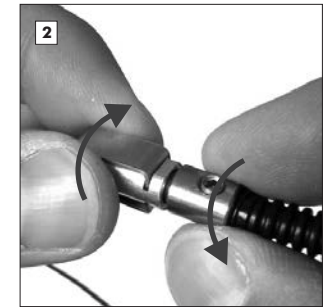

3.2 Joining together of the external gear mech:

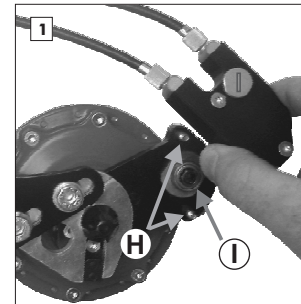

Rejoining the gear mech involves remounting the cable box. Place the twist shifter into gear #14 then place cable box **E** over the hexagonal peg **I**, so that the two locating pegs **H** sit into the two holes in the back of the cable box. Turn the twist shifter back and forth around gear #14 until the cable box falls into place over the hexagonal peg. Lastly tighten up the knurled head screw.

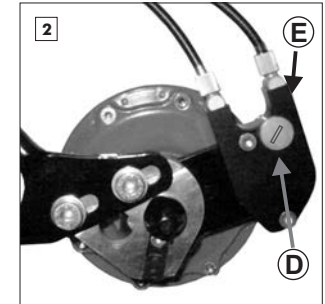

ATTENTION !

Should all 14 gears not be selectable after fitting the cable box, it will be down to the hub or the twist shifter not being in gear #14. There are two methods to correct this.

Method 1:

Remove cable box and turn the twist shifter into gear #1. Refit cable box and shift until it can no longer be turned. If you are not in gear #14 of the twist shifter then disconnect the cable box and turn the twist shifter into gear #14. Now reconnect the cable box to have access to all 14 gears.

Method 2:

Remove the cable box and turn the twist shifter into gear #14. Take an 8mm wrench and use it to turn the hexagonal peg on the external transfer box anticlockwise until it reaches the end stop. Now the hub is in gear #14, so the cable box can be remounted.

Technical data

Number of gears:	14
Gear increases:	even 13.6%
Range of gears:	526%
Frame spacing:	135mm (XL Version = 170mm/XXL Version = 190mm)
Number of spoke holes:	32/36 (XL/XXL Version = 32 hole only)
Spoke flange distance:	58mm, symmetrical (XL/XXL Version = 93mm)
Spoke hole circle diameter:	Ø100mm
Spoke hole diameter:	Ø2.7mm
Spoke flange width:	3.2mm
Axle diameter at dropout:	9.8mm
Axle overall width CC:	147mm (XL Version = 182mm/XXL Version 202mm)
Hollow axle inner diameter:	Ø5.5mm, for quick release lever
Total axle width TS:	171mm / TS long 179mm
Total axle width TS (XL Version):	206mm / TS long 214mm
Axle thread TS:	M10x1
Center disc mounting diameter:	Ø52mm
Mounting bolt hole circle diameter:	Ø65mm
Brake disc mounting bolts:	4 x M8x0.75
Distance between dropout and center disc mount:	16.3mm (Is1999)
Weight:	1700g (CC), 1800g (CC EX), 1825g (CC DB)
Weight (XL Version/XXL Version)	1980g (XL CC DB OEM2) / 2005g (XXL CC DB OEM2)
Oil volume:	25ml max.
Sprocket thread:	M34x6 P1, tolerance 6H
Sprocket type:	for bicycle chain 1/2" x 3/32" (ISO Nr. 082)
Number of sprocket teeth (16 standard):	13, 15, 16, 17 threaded- or 13-19 + 21 splined-sprocket
Chainline (135mm/142mm):	54mm (58mm for 13T & all splined sprockets)
Chainline (XL/XXL Version):	72mm (75mm for 13T & all splined sprockets)
Smallest permissible gear ratios : 40/21, 36/19, 34/18, 32/17, 30/16, 28/15, 28/14, 26/13 (transm.-factor ~ 1.90) (Riders over 100kg/tandem): 53/21, 48/19, 45/18, 42/17, 40/16, 38/15, 36/14, 34/13 (transm.-factor ~ 2.50)	
Gates Carbondrive beltline:	54.75mm (XL/XXL Version = 72)
Smallest permissible belt sprocket ratios (26"): 39/19, 39/20, 42/22, 46/24 (transmission factor ~ 1.90) (Riders over 100kg/tandem): 46/19, 50/20, 55/22, 60/24 (transmission factor ~ 2.50)	
Maximum input torque:	130Nm
Gear control:	by twist shifter (version right or left)
Twist shifter angle per gear change:	21°/273°
Gear control transfer:	via two shifter cables (pull-pull system)
Shifter cable movement per gear change:	7.4mm/96,2mm
Inner gear ratios (hub rotation per sprocket rotation):	
Gear #1:	0.279
Gear #2:	0.316
Gear #3:	0.360
Gear #4:	0.409
Gear #5:	0.464
Gear #6:	0.528
Gear #7:	0.600
Gear #8:	0.682
Gear #9:	0.774
Gear #10:	0.881
Gear #11:	1.000
Gear #12:	1.135
Gear #13:	1.292
Gear #14:	1.467

Weight comparison

The Rohloff SPEEDHUB 500/14 is with a weight of 120g per gear, the lightest gear hub on the market. The gear range is the same as high quality 27 gear derailleur systems due to the 14 gears within the hub being evenly spaced out at 13.6% increases. With the Rohloff SPEEDHUB 500/14 there is no longer a need for the following parts:

- Front and rear derailleur
- Two shifters including
- Rear hub with cassette
- Small and middle chainrings
- The total average weight of all these components is approx. 1600g.

The weight of a fitted Rohloff SPEEDHUB 500/14 CC OEM including twist shifter, shifter cables and cable guide is approx. 1820g.

The comparison between the Rohloff SPEEDHUB 500/14 and the derailleur system shows only a slight increase in weight. For that, the user receives a:

- Service-free,
- dirt-free full-encapsulated,
- user-friendly gear system and
- high reliability
- alongwith a long life span.

Comparison of mechanical efficiency

The mechanical efficiency* and consequently the size of the loss of the Rohloff SPEEDHUB 500/14 is entirely comparable with that of the derailleur system.

The losses of a derailleur system consist of the friction caused by the bottom bracket, chain, cassette and the hub bearings. The amount of friction loss depends on the size of the sprockets, the angle of the chain line and condition of wear. In reality this proves to be 1 - 5%, leaving the derailleur system with a working efficiency lying between 95% and 99%.

The losses of the Rohloff SPEEDHUB 500/14 are caused by the friction coming from the bottom bracket, chain and gearbox. Here, however, the chain runs in a straight line from just one chainring reducing sideways friction on the sprockets. Most of the friction occurs when all the planetary gear sets are used within the gearbox. The overall average loss of the gears within the Rohloff SPEEDHUB 500/14 is approximately 1 - 5%, leaving the working efficiency between 95% and 99%.

The Rohloff SPEEDHUB 500/14 is, therefore, consequently an optimum choice for the everyday and sports rider.

* More detailed info over the working efficiency is to be found on the web under www.rohloff.de.

Sprocket ratios

The Rohloff SPEEDHUB 500/14 has a 526% range of gears, that means gear #14 is 5.26 times greater than gear #1. The 14 gears are evenly spaced out over this range in 13.6% increases. Through the choice of chainring and sprocket in use, the Rohloff SPEEDHUB 500/14 can be tuned for the specific riding purpose. The Rohloff SPEEDHUB 500/14 comes standard with a 16 tooth sprocket. 13, 15 and 17 tooth sprockets are available as alternatives.

In the following tables the distance travelled per crank revolution is listed for gears #1 and #14. The listed distance travelled per crank revolution is shown in the tables for a variety of sprocket ratios and wheel sizes (20", 26" and 28" wheels).

When the particular wheel/sprocket/chainring size and gear is not listed in the tables, then the following formula can be used to calculate the exact distance travelled per crank revolution of the Rohloff SPEEDHUB 500/14:

$$\text{Distance travelled per crank revolution} = W \times C_s \times S \times \text{IGR}$$

Formula key:

- W = Wheel circumference
- C = Chainring size
- S = Sprocket size
- IGR = Inner gear ratio listed in the following table

Inner gear ratio IGR = hub revolutions per sprocket revolutions of the Rohloff SPEEDHUB 500/14

gear #	1	2	3	4	5	6	7	8	9	10	11	12	13	14
IGR	0.279	0.316	0.360	0.409	0.464	0.528	0.600	0.682	0.774	0.881	1.000	1.135	1.292	1.467

The tables or the following formula can be used to compare the Rohloff SPEEDHUB 500/14 to a derailleur gear system:

$$\text{Ratio of the derailleur gear system} = C_s \times S$$

$$\text{Ratio of the Rohloff SPEEDHUB 500/14} = \text{IGR} \times C_s \times S$$

Smallest permissible sprocket ratios (solo 100kg)

The sprocket ratio on the Rohloff SPEEDHUB 500/14 (e.g. 42:16) converts the slow rotational speed at the crank into a fast rotational speed at the sprocket and reduces the input torque for the Rohloff SPEEDHUB 500/14 in the same proportion. To prevent overstraining the hub, a **minimum sprocket ratio of 1.90** must be used. With the available sprockets these minimum ratios are achieved by: **40:21, 36:19, 34:18, 32:17, 30:16, 28:15, 28:14, 26:13**. This resembles a derailleur transmission of 22:40. Larger chainrings can be used without exceptions.



If mounted on a tandem or if the rider weighs over 100kg, the following sprocket ratios must not be undercut: 53:21, 48:19, 45:18, 42:17, 40:16, 38:15, 36:14, 34:13. This equates to a transmission factor of 2.50.

Distance traveled per crank revolution - 20" Wheels (circumference 1.51m)

Sprocket Chainring	13 teeth		14 teeth		15 teeth		16 teeth		17 teeth		18 teeth		19 teeth		21 teeth		
	from	to	from	to	from	to	from	to	from	to	from	to	from	to	from	to	
26 teeth	0.84m	- 4.43m	0.78m	- 4.11m													
28 teeth	0.91m	- 4.77m	0.84m	- 4.43m	0.79m	- 4.13m											
29 teeth	0.97m	- 5.11m	0.90m	- 4.75m	0.84m	- 4.43m	0.79m	- 4.15m									
30 teeth	1.04m - 5.45m	0.96m	- 5.06m	0.90m	- 4.73m	0.84m	- 4.43m	0.79m	- 4.17m								
31 teeth	1.10m	- 5.79m	1.02m	- 5.38m	0.95m	- 5.02m	0.90m	- 4.71m	0.84m	- 4.43m	0.80m	- 4.18m					
32 teeth	1.17m	- 6.13m	1.08m - 5.70m	1.01m	- 5.32m	0.95m	- 4.98m	0.89m	- 4.69m	0.84m	- 4.43m	0.80m	- 4.20m				
38 teeth	1.23m	- 6.48m	1.14m	- 6.01m	1.07m - 5.61m	1.00m	- 5.26m	0.94m	- 4.95m	0.89m	- 4.68m	0.84m	- 4.43m				
40 teeth	1.30m	- 6.82m	1.20m	- 6.33m	1.12m	- 5.91m	1.05m - 5.54m	0.99m	- 5.21m	0.94m	- 4.92m	0.89m	- 4.66m	0.80m	- 4.22m		
42 teeth	1.36m	- 7.16m	1.26m	- 6.65m	1.18m	- 6.20m	1.11m	- 5.81m	1.04m - 5.47m	0.98m	- 5.17m	0.93m	- 4.90m	0.84m	- 4.43m		
44 teeth	1.43m	- 7.50m	1.32m	- 6.96m	1.24m	- 6.50m	1.16m	- 6.09m	1.09m	- 5.73m	1.03m - 5.41m	0.98m	- 5.13m	0.88m	- 4.64m		
46 teeth	1.49m	- 7.84m	1.38m	- 7.28m	1.29m	- 6.79m	1.21m	- 6.37m	1.14m	- 5.99m	1.08m - 5.66m	1.02m	- 5.36m	0.92m	- 4.85m		
48 teeth	1.56m	- 8.18m	1.44m	- 7.59m	1.35m	- 7.09m	1.26m	- 6.65m	1.19m	- 6.25m	1.12m	- 5.91m	1.06m - 5.60m	0.96m	- 5.06m		
50 teeth	1.62m	- 8.52m	1.50m	- 7.91m	1.40m	- 7.38m	1.32m	- 6.92m	1.24m	- 6.52m	1.17m	- 6.15m	1.11m	- 5.83m	1.00m	- 5.27m	
52 teeth	1.69m	- 8.86m	1.56m	- 8.23m	1.46m	- 7.68m	1.37m	- 7.20m	1.29m	- 6.78m	1.22m	- 6.40m	1.15m	- 6.06m	1.04m - 5.49m		

Distance traveled per crank revolution - 26" Wheels (circumference 2.06m)

Sprocket Chainring	13 teeth		14 teeth		15 teeth		16 teeth		17 teeth		18 teeth		19 teeth		21 teeth		
	from	to	from	to	from	to	from	to	from	to	from	to	from	to	from	to	
26 teeth	1.15m	- 6.04m	1.07m	- 5.61m													
28 teeth	1.24m	- 6.51m	1.15m	- 6.04m	1.07m	- 5.64m											
30 teeth	1.33m	- 6.97m	1.23m	- 6.48m	1.15m	- 6.04m	1.08m	- 5.67m									
32 teeth	1.41m	- 7.44m	1.31m	- 6.91m	1.23m	- 6.45m	1.15m	- 6.04m	1.08m	- 5.69m							
34 teeth	1.50m	- 7.90m	1.40m	- 7.34m	1.30m	- 6.85m	1.22m	- 6.42m	1.15m	- 6.04m	1.09m	- 5.71m					
36 teeth	1.59m	- 8.37m	1.48m - 7.77m	1.38m	- 7.25m	1.29m	- 6.80m	1.22m	- 6.40m	1.15m	- 6.04m	1.09m	- 5.73m				
38 teeth	1.68m	- 8.83m	1.56m	- 8.20m	1.46m - 7.66m	1.37m	- 7.18m	1.28m	- 6.76m	1.21m	- 6.38m	1.15m	- 6.04m				
40 teeth	1.77m	- 9.30m	1.64m	- 8.63m	1.53m	- 8.06m	1.44m - 7.56m	1.35m	- 7.11m	1.28m	- 6.72m	1.21m	- 6.36m	1.09m	- 5.76m		
42 teeth	1.86m	- 9.76m	1.72m	- 9.07m	1.61m	- 8.46m	1.51m	- 7.93m	1.42m - 7.47m	1.34m	- 7.05m	1.27m	- 6.68m	1.15m	- 6.04m		
44 teeth	1.95m	- 10.23m	1.81m	- 9.50m	1.69m	- 8.86m	1.58m	- 8.31m	1.49m	- 7.82m	1.40m	- 7.39m	1.33m	- 7.00m	1.20m	- 6.33m	
46 teeth	2.03m	- 10.69m	1.89m	- 9.93m	1.76m	- 9.27m	1.65m	- 8.69m	1.56m	- 8.18m	1.47m - 7.72m	1.39m	- 7.32m	1.26m	- 6.62m		
48 teeth	2.12m	- 11.16m	1.97m	- 10.36m	1.84m	- 9.67m	1.72m	- 9.07m	1.62m	- 8.53m	1.53m	- 8.06m	1.45m - 7.63m	1.31m	- 6.91m		

Distance traveled per crank revolution - 28" Wheels (circumference 2.18m)

Sprocket Chainring	13 teeth		14 teeth		15 teeth		16 teeth		17 teeth		18 teeth		19 teeth		21 teeth		
	from	to	from	to	from	to	from	to	from	to	from	to	from	to	from	to	
26 teeth	1.22m	- 6.40m	1.13m	- 5.94m													
28 teeth	1.31m	- 6.89m	1.22m	- 6.40m	1.14m	- 5.97m											
30 teeth	1.40m	- 7.38m	1.30m	- 6.85m	1.22m	- 6.40m	1.14m	- 6.00m									
32 teeth	1.50m - 7.87m	1.39m	- 7.31m	1.30m	- 6.82m	1.22m	- 6.40m	1.14m	- 6.02m								
34 teeth	1.59m	- 8.36m	1.48m	- 7.77m	1.38m	- 7.25m	1.29m	- 6.80m	1.22m	- 6.40m	1.15m	- 6.04m					
36 teeth	1.68m	- 8.86m	1.56m - 8.22m	1.46m	- 7.68m	1.37m	- 7.20m	1.29m	- 6.77m	1.22m	- 6.40m	1.15m	- 6.06m				
38 teeth	1.78m	- 9.35m	1.65m	- 8.68m	1.54m - 8.10m	1.44m	- 7.60m	1.36m	- 7.15m	1.28m	- 6.75m	1.22m	- 6.40m				
40 teeth	1.87m	- 9.84m	1.74m	- 9.14m	1.62m	- 8.53m	1.52m - 8.00m	1.43m	- 7.52m	1.35m	- 7.11m	1.28m	- 6.73m	1.16m	- 6.09m		
42 teeth	1.97m	- 10.33m	1.82m	- 9.59m	1.70m	- 8.95m	1.60m	- 8.39m	1.50m - 7.90m	1.42m	- 7.46m	1.34m	- 7.07m	1.22m	- 6.40m		
44 teeth	2.06m	- 10.82m	1.91m	- 10.05m	1.78m	- 9.38m	1.67m	- 8.79m	1.57m	- 8.28m	1.49m	- 7.82m	1.41m	- 7.41m	1.27m	- 6.70m	
46 teeth	2.15m	- 11.32m	2.00m	- 10.51m	1.87m	- 9.81m	1.75m	- 9.19m	1.65m	- 8.65m	1.55m - 8.17m	1.47m	- 7.74m	1.33m	- 7.01m		
48 teeth	2.25m	- 11.81m	2.09m	- 10.96m	1.95m	- 10.23m	1.82m	- 9.59m	1.72m	- 9.03m	1.62m	- 8.53m	1.54m - 8.08m	1.39m	- 7.31m		
50 teeth	2.34m	- 12.30m	2.17m	- 11.42m	2.03m	- 10.66m	1.90m	- 9.99m	1.79m	- 9.41m	1.69m	- 8.88m	1.60m	- 8.42m	1.45m	- 7.61m	

Distance traveled per crank revolution - 29" Wheels (circumference 2.30m)

Sprocket Chainring	13 teeth		14 teeth		15 teeth		16 teeth		17 teeth		18 teeth		19 teeth		21 teeth		
	from	to	from	to	from	to	from	to	from	to	from	to	from	to	from	to	
26 teeth	1.28m	- 6.75m	1.19m	- 6.27m													
28 teeth	1.38m	- 7.27m	1.28m	- 6.75m	1.20m	- 6.30m											
30 teeth	1.48m	- 7.79m	1.38m	- 7.23m	1.28m	- 6.75m	1.20m	- 6.33m									
32 teeth	1.58m - 8.31m	1.47m	- 7.71m	1.37m	- 7.20m	1.28m	- 6.75m	1.21m	- 6.35m								
34 teeth	1.68m	- 8.82m	1.56m	- 8.19m	1.45m	- 7.65m	1.36m	- 7.17m	1.28m	- 6.75m	1.21m	- 6.37m					
36 teeth	1.78m	- 9.34m	1.65m - 8.68m	1.54m	- 8.10m	1.44m	- 7.59m	1.36m	- 7.15m	1.28m	- 6.75m	1.22m	- 6.39m				
38 teeth	1.88m	- 9.86m	1.74m	- 9.16m	1.63m - 8.55m	1.52m	- 8.01m	1.43m	- 7.54m	1.35m	- 7.12m	1.28m	- 6.75m				
40 teeth	1.97m	- 10.38m	1.83m	- 9.64m	1.71m	- 9.00m	1.60m - 8.44m	1.51m	- 7.94m	1.43m	- 7.50m	1.35m	- 7.10m	1.22m	- 6.43m		
42 teeth	2.07m	- 10.90m	1.93m	- 10.12m	1.80m	- 9.45m	1.68m	- 8.86m	1.59m - 8.34m	1.50m	- 7.87m	1.42m	- 7.46m	1.28m	- 6.75m		
44 teeth	2.17m	- 11.42m	2.02m	- 10.60m	1.88m	- 9.90m	1.76m	- 9.28m	1.66m	- 8.73m	1.57m	- 8.25m	1.49m	- 7.81m	1.34m	- 7.07m	

Table of distance travelled per crank revolution for 27.5" (650B) wheels:

Derailleur gears in comparison to Rohloff SPEEDHUB 500/14

The table shows which sprocket ratio on the *Rohloff SPEEDHUB 500/14* must be used to resemble the smallest transmission of a derailleur gear system.

Smallest sprocket ratio of derailleur gears	Gear #1 Rohloff SPEEDHUB 500/14 sprocket ratio			
22/40	26/13	28/15	32/16	34/17
24/40	28/13	32/15	34/16	36/17
26/42	28/13	34/15	36/16	38/17
20/34	28/13	32/15	34/16	36/17
22/34	30/13	34/15	38/16	40/17
24/34	32/13	38/15	40/16	44/17
26/34	36/13	42/15	44/16	46/17
20/32	30/13	34/15	36/16	38/17
22/32	32/13	36/15	40/16	42/17
24/32	34/13	40/15	44/16	46/17
26/32	38/13	44/15	46/16	50/17
20/30	32/13	36/15	38/16	40/17
22/30	34/13	40/15	42/16	44/17
24/30	38/13	44/15	46/16	48/17
26/30	40/13	46/15	50/16	52/17

The table shows which sprocket ratio on the *Rohloff SPEEDHUB 500/14* must be used to resemble the largest transmission of a derailleur gear system.

Largest sprocket ratio of derailleur gears	Gear #14 Rohloff SPEEDHUB 500/14 sprocket ratio			
26/10	-	26/15	28/16	30/17
28/10	24/13	28/15	30/16	32/17
30/10	26/13	30/15	32/16	34/17
32/10	28/13	32/15	34/16	38/17
34/10	30/13	34/15	38/16	40/17
36/10	32/13	36/15	40/16	42/17
38/10	34/13	38/15	42/16	44/17
40/10	36/13	40/15	44/16	46/17
42/10	38/13	44/15	46/16	48/17
32/11	26/13	30/15	32/16	34/17
34/11	28/13	32/15	34/16	36/17
36/11	30/13	34/15	36/16	38/17
38/11	30/13	36/15	38/16	40/17
40/11	32/13	38/15	40/16	42/17
42/11	34/13	40/15	42/16	44/17
44/11	36/13	40/15	44/16	46/17
46/11	38/13	42/15	46/16	48/17
48/11	38/13	44/15	48/16	50/17
50/11	40/13	46/15	50/16	52/17
52/11	42/13	48/15	52/16	54/17
54/11	44/13	50/15	54/16	56/17
38/12	28/13	32/15	34/16	36/17
40/12	30/13	34/15	36/16	38/17
42/12	32/13	36/15	38/16	40/17
44/12	32/13	38/15	40/16	42/17
46/12	34/13	40/15	42/16	44/17
48/12	36/13	40/15	44/16	46/17
50/12	36/13	42/15	46/16	48/17
52/12	38/13	44/15	48/16	50/17
54/12	40/13	46/15	50/16	52/17

Rohloff SPEEDHUB 500/14 in comparison to derailleur gears

The table shows which smallest and largest sprocket ratio of derailleur gears resembles the existing transmission of the *Rohloff SPEEDHUB 500/14*.

Sprocket ratio (chainring/sprocket) <i>Rohloff SPEEDHUB 500/14</i>	Gear #1 resembles a derailleur gear sprocket ratio of		Gear #14 resembles a derailleur gear sprocket ratio of	
38/13	22/26	24/30	48/11	52/12
40/13	22/25	24/27	50/11	54/12
42/13	22/24	24/26	52/11	56/12
44/13	22/23	24/25	54/11	60/12
46/13	22/22	or 24/24	58/11	or 62/12
48/13	22/21	24/23	60/11	64/12
50/13	22/20	24/22	62/11	68/12
52/13	22/19	24/21	64/11	70/12
54/13	22/18	24/20	68/11	74/12
38/15	22/32	24/34	42/11	44/12
40/15	22/30	24/32	44/11	46/12
42/15	22/28	24/30	46/11	50/12
44/15	22/26	24/29	48/11	52/12
46/15	22/25	or 24/28	50/11	or 54/12
48/15	22/24	24/26	52/11	56/12
50/15	22/23	24/25	54/11	58/12
52/15	22/22	24/24	56/11	62/12
54/15	22/21	24/23	60/11	64/12
38/16	22/34	24/36	38/11	42/12
40/16	22/30	24/34	40/11	44/12
42/16	22/30	24/32	42/11	46/12
44/16	22/28	24/32	44/11	48/12
46/16	22/27	or 24/30	46/11	or 50/12
48/16	22/26	24/28	48/11	52/12
50/16	22/25	24/27	50/11	56/12
52/16	22/24	24/26	52/11	58/12
54/16	22/23	24/25	54/11	60/12
40/17	22/34	24/36	38/11	42/12
42/17	22/32	24/34	40/11	44/12
44/17	22/30	24/34	42/11	46/12
46/17	22/29	or 24/32	44/11	or 48/12
48/17	22/27	24/30	46/11	50/12
50/17	22/26	24/29	48/11	52/12
52/17	22/25	24/28	50/11	54/12
54/17	22/24	24/27	52/11	56/12



Securing to the frame

Modular parts system

There are basically three different versions of the Rohloff SPEEDHUB 500/14. One with a quick release axle (CC versions), one with a threaded axle (TS versions) and one with a 12mm Thru axle frame compatible axle (A12 versions). The only other differences are with regards to the peripheral components. The wide range of these components enable the Rohloff SPEEDHUB 500/14 to be mounted into nearly every type of bicycle frame.

Gear mech (two options)

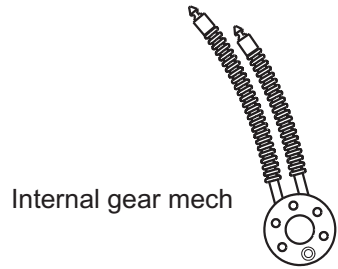

Internal gear mech

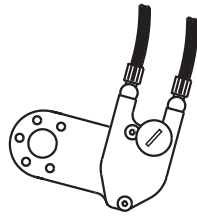

External gear mech (EX)

Torque anchoring (4 options)

Long torque arm for mounting to standard frames

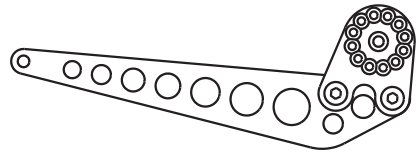

OEM mounting for special frames with Rohloff OEM dropouts



OEM2 mounting for frames with international standard disc brake mounts (IS2000)



PM mounting for frames with an integrated Postmount brake caliper mount



Hub cap (two options)

For bikes using a rim brake typ (CC / TS) on the rear wheel

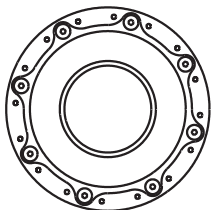

For bikes using a disc brake Typ (CC DB / TS DB) on the rear wheel with EX - gear mech

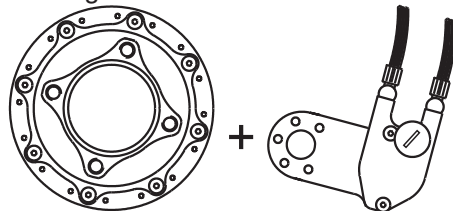

Securing to the frame

Axle types

The Rohloff SPEEDHUB 500/14 is available with different axle types. The CC versions come with a hollow axle for use with a quick release lever. The TS versions come with a threaded axle for use with standard M10x1 nuts for securing to the frame and the A12 version are for Thru Axle compatible frames. These are secured via 2x M7x1 bolts and special frame reduction sleeves inserted into the 12mm Thru axle dropouts. The 14 gear mechanism on all versions is primarily the same.



Rohloff SPEEDHUB 500/14 CC (quick release axle)



Rohloff SPEEDHUB 500/14 TS (threaded axle)



Rohloff SPEEDHUB 500/14 A12-PM (for 12x142mm thruaxle frames)



Rohloff SPEEDHUB 500/14 CC XL 170mm (Fatbikes)

Torque securing

With all gear hubs the axle tries to rotate whilst cycling. When cycling in a reduction gear, the axle attempts to rotate backwards. When cycling in an increasing gear, the axle attempts to rotate forwards. The force with which the axle tries to turn is referred to as torque. The amount of torque depends upon the force applied on the pedals and the gear selected. This torque must be anchored by some means to the frame in order to create forward drive.

On the simple three-speed hubs a flat sided axle is sufficient to secure the torque within the dropout. On a high performance internal gear hub like the *Rohloff SPEEDHUB 500/14* the method of anchoring the torque must be considerably more stable due to the wide range of gear ratios.

The amount of torque produced is shown in the following table:

Torque in percent of crank torque with a 42/16 sprocket ratio														
Gear	1	2	3	4	5	6	7	8	9	10	11	12	13	14
%	98%	82%	68%	55%	44%	34%	25%	18%	11%	5%	0%	5%	9%	12%
Torque	Backward rotation										Forward rotation			

Backwards torque rotation ⊖ see picture below or next page, pictures 1, 2 and 3

When the rider applies 20kg onto the pedal, he produces a crank torque of 34Nm. In gear #8 this results in 6Nm torque on the torque arm (18% of crank torque). With the same crank torque of 34Nm in gear #1 this results in 33Nm torque on the torque arm (98% of crank torque). Gear #11 is the direct drive (1:1) the torque on the torque arm is always zero.



Rohloff SPEEDHUB 500/14 CC OEM mounted in a frame with adjustable Rohloff OEM dropouts

Depending on the type of frame one of three options can be used to secure the torque.

- 1) Standard axleplate with long torque arm
- 2) OEM axleplate
- 3) OEM2 axleplate

All three anchoring options ensure the axleplate is secured to the frame in two positions to prevent the axle from rotating. The first point **A** is the axle peg that is secured to the left side dropout. This is the same for all three options. The difference between the three options is point **B**. The hole pattern on the axleplates allow for individual adjustment of the gear mechs in steps of 30°, so that nearly every frame type can receive an optimum cable routing.

1) Standard axleplate with long torque arm

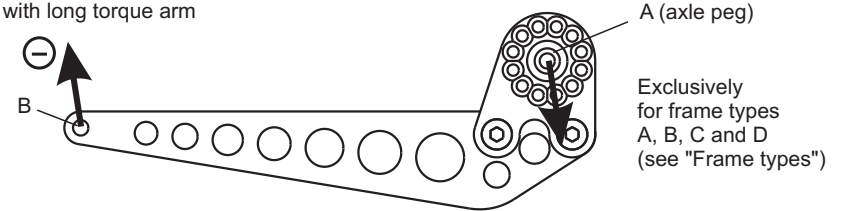

The long torque arm is bolted behind the axleplate. The narrow end **B** is secured to the frame by means of a clamp or a quick release block. The axle is prevented from turning through these two points. When removing the wheel, the torque arm must first be released from the frame at the narrow end **B**.

2) OEM axleplate

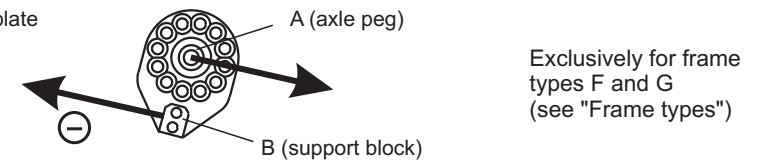

The mounting of hubs with an OEM axle plate is only possible on frames fitted with *Rohloff* OEM dropouts. The OEM axleplate sits in the dropout slot of the OEM dropout. The axle peg **A** slides in first followed by the support block **B** into the same slot. The dropout itself prevents these two parts from turning. When removing the wheel, the two parts fall out the dropout together once the axle has been loosened.

3) OEM2 axleplate

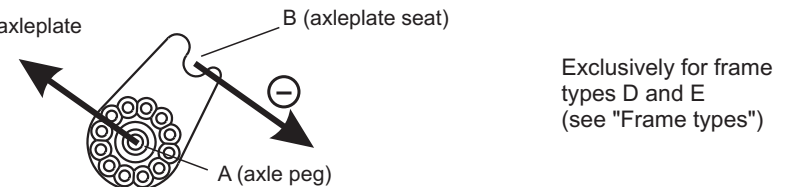

Mounting the *SPEEDHUB 500/14* using an OEM2 axleplate is only permitted on frames with international standard (IS1999) disc brake mounts. The OEM2 axleplate sits with its axle peg **A** in the dropout. The axleplate seat **B** secures itself around the supporting peg of the *Rohloff SPEEDBONE* or *MonkeyBone* (when mounted on a bike with disc brakes) or around the support bolt fastened through the lower brake caliper mounting hole (when mounted on a bike with rim brakes). When removing the wheel, the axleplate falls away from the support bolt/*Rohloff SPEEDBONE* / *MonkeyBone* and out of the dropout once the axle is loosened..

Frame types

The Rohloff SPEEDHUB 500/14 requires a frame spacing of 135mm, all frames with different frame spacing or for thru axles are not suitable for the Rohloff SPEEDHUB 500/14. The inner side of the left hand dropout must be flat in a diameter of 40mm around the center of the axle so that the axle plate can sit firmly and evenly against the dropout. There are different Rohloff SPEEDHUB 500/14 versions available (for the different dropout types) with the suitable axle and axle plate along with the corresponding parts for mounting. The Rohloff SPEEDHUB 500/14 does not include a brake. To mount a brake (disc or rim), the frame must have the correct brake mounts.

Frame types for the long torque arm:

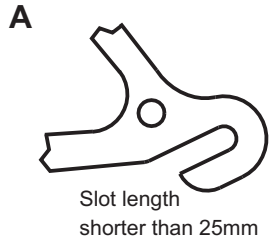

On frames with horizontal dropout slots, it is only possible to mount the Rohloff SPEEDHUB 500/14 in the TS threaded axle versions (TS and TS EX). The CC versions with a quick release lever will not hold the wheel secure enough and the wheel could be pulled crooked whilst riding.

When the slot length is shorter than 25mm (A), a chain tensioner (Art. #8250) must be fitted as there is not enough adjustment room within the slot to tension the chain.

The following versions of the Rohloff SPEEDHUB 500/14 are, therefore, suitable:
TS*
TS EX*

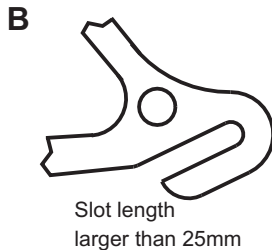

When the slot length is longer than 25mm (B), a chain tensioner does not have to be used as there is enough adjustment room within the slot to tension the chain.

The following versions of the Rohloff SPEEDHUB 500/14 are, therefore, suitable:
TS
TS EX



On frames with vertical dropout slots (C) the mounting of the Rohloff SPEEDHUB 500/14 normally suggests a CC quick release version (CC or CC EX). This as opposed to the TS versions (TS and TS EX) allows for a quicker wheel removal/installation without the use for tools.

The following versions of the Rohloff SPEEDHUB 500/14 are, therefore, suitable:
CC
CCEX
TS*
TS EX*

* These versions must be used in conjunction with a chain tensioner (Art.No. 8250) except when an eccentric BB is being used.. The chain tensioner should be ordered with the initial product as it is not to be found in the regular package.

Frame types for OEM2 mounting

For frames with vertical dropouts and international standard disc brake mounts (IS 1999), the use of an OEM2 axleplate is highly recommended. With this, the disc brake mount will be used to secure the torque of the hub. Two mounting possibilities are to be decided between:

1) Mounting with a disc brake on the rear wheel

The torque is secured through the Rohloff SPEEDBONE (Art. #8550), MonkeyBone (160mm= Art. #8553/ 180mm=Art. #8554), then through the disc brake mounts and secured tightly into the brake disc caliper.

2) Mounting without a disc brake on the rear wheel

The Rohloff SPEEDBONE/MonkeyBone is not necessary. A support bolt secured through the lower disc brake mount can be used to support the torque.

ATTENTION

When mounting on Tandems even without the use of a disc brake, the Rohloff SPEEDBONE/Monkey Bone must be mounted and its supporting peg used to support the torque of the OEM2 axleplate. A chain tensioner must also be mounted in conjunction with the use of the OEM2 mounting, except on frames built around an eccentric BB system.

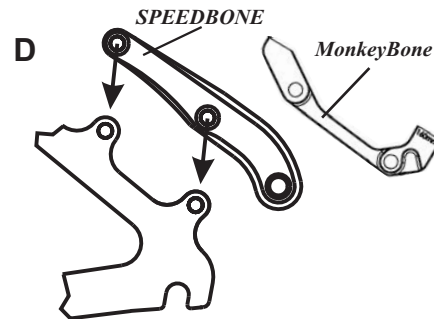

On frames (D) with international disc brake mounts (IS 1999), the OEM2 mounting is recommended. As an alternative the long torque arm could also be used (see frame type C).

All Rohloff SPEEDHUB 500/14 versions can be mounted on this frame type, the only accessory needed is the OEM2 axleplate.

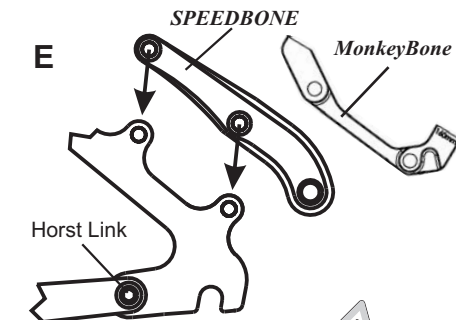

On frame types (E) with a Horst Link, the mounting is only possible with the use of the OEM2 axleplate.

All Rohloff SPEEDHUB 500/14 versions can be mounted on this frame type, the only accessory needed is the OEM2 axleplate.

Horst Link, named after his inventor Horst Leitner.

ATTENTION

When mounting the hub with the use of the OEM2 axle plate, the disc brake mounts will be used to secure the torque of the hub. Therefore, permission must be obtained from the frame manufacturer to ensure that the guarantee is not affected. The mounting instructions for the OEM2 usage must be read carefully (see "Mounting instructions for OEM2").

Frame types for OEM mounting

Rigid frames with Rohloff OEM dropouts are specially designed for the mounting of all Rohloff SPEEDHUB 500/14 OEM versions. The long slot in the left hand dropout holds the support block of the OEM axle plate.

F

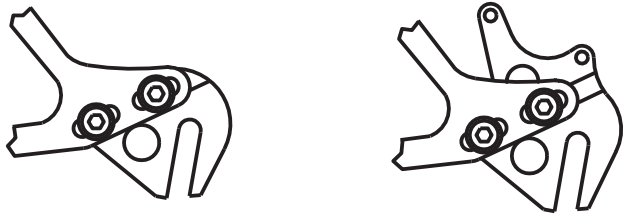

Frame types (**F**) have adjustable Rohloff OEM dropouts. With these dropouts on a hardtail frame, the need for a chain tensioner is eliminated because the wheel (once secured into the dropout inserts) can be pulled backwards to tension the chain. The dropout inserts are available from a variety of manufacturers with or without disc brake mounts and are all interchangeable (supply information is available under www.rohloff.de). All Rohloff SPEEDHUB 500/14 OEM versions are suitable for these frame types.

G

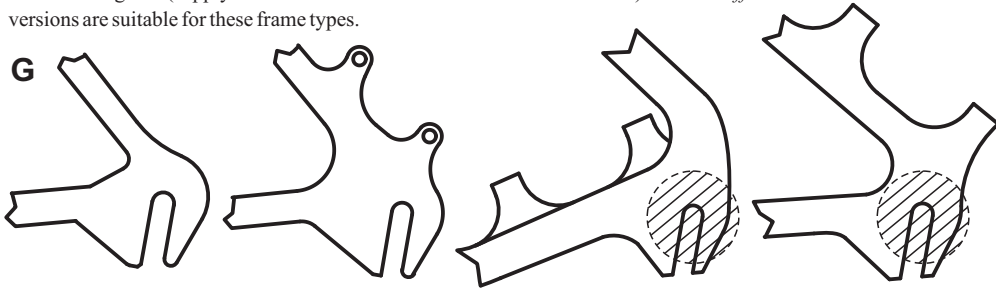

Frame types (**G**) have unadjustable Rohloff OEM dropout and are specially designed for rear suspension models. A chain tensioner must be mounted, because the distance between the chainring and sprocket varies as the rear suspension is activated. All Rohloff SPEEDHUB 500/14 OEM versions are suitable for these frame types.

ATTENTION

All versions mounted to frame types **G** must be used in conjunction with a chain tensioner (Art.No. 8250) except when an eccentric BB is being used. A chain tensioner should be ordered with the initial product as it is not to be found in the regular OEM package.

ATTENTION

No matter what shape the left-hand dropout is, a surface of 40mm diameter around the center of the axle must be flat to allow the axle plate to sit firmly and evenly against the inner side of the left-hand dropout. This area is shown in the diagram below.

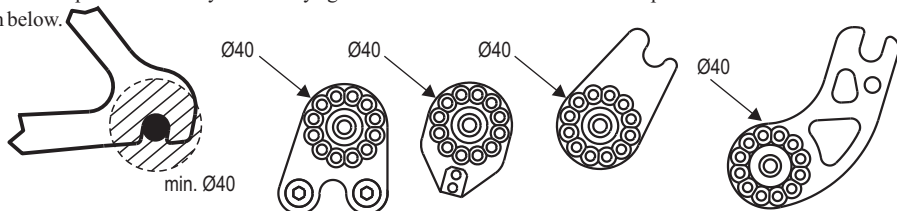

Diagram 1: Flat left dropout surface and three different axle plates

Mounting necessities OEM2

ATTENTION

For safe OEM2 mounting with the support bolt or the Rohloff SPEEDBONE / MonkeyBone, the following points must be well noted:

The disc brake mounts must be one piece with the dropout itself, be of international standard (IS1999) and have the following minimum dimension requirements:

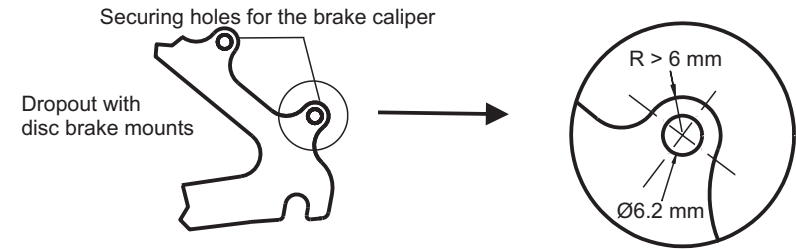

Requirement for the OEM2 mounting of the Rohloff SPEEDHUB 500/14 with a support bolt is the position of the disc brake mounts. When the mount hole nearest the axle is behind a vertical line **C** up from the axle center (diagram 1), then the support bolt can be used. When the hole is in front of the vertical line **C** (diagram 2), then the use of the support bolt is not permitted.

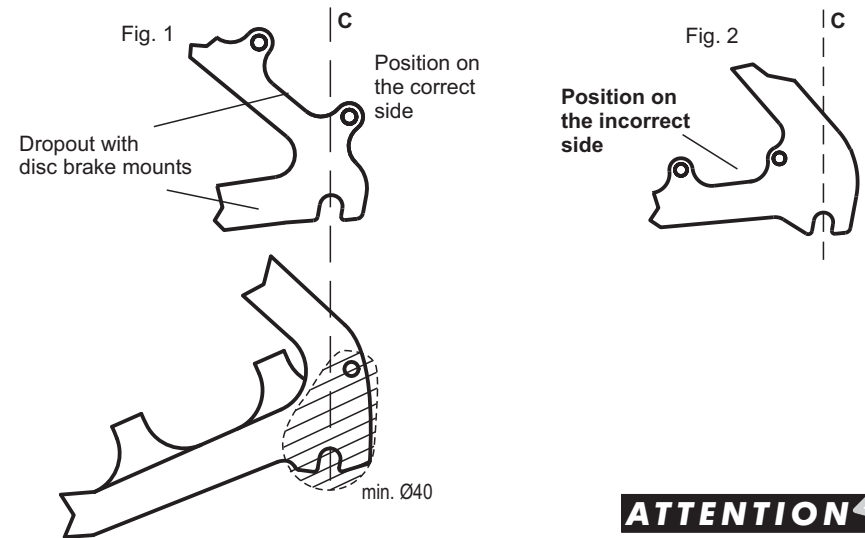

ATTENTION

When permission has not been granted by the frame manufacturer to mount the Rohloff SPEEDBONE / MonkeyBone or the support bolt through the disc brake mount, then mounting of the OEM2 versions is at your own risk.

Further compatibility information can be found under:
www.rohloff.de > FAQ > SPEEDHUB > Axleplates and Dropouts

Internal gear mech

With the internal gear mech the shifter cables run from the twist shifter to the cable guide, which can be mounted to the left hand brake boss or clamped to the left hand chainstay. The internal gear mech involves the use of two hub cables. They must be connected to the shifter cables by the use of bayonet connectors which allow a quick separation for wheel removal. The internal gear mech is not compatible with the use of a rear disc brake as the hub cables and bayonet connectors may rub on the disc. The hole pattern in the axle plate allows the adjustment of the gear mech in steps of 30°. Therefore, an optimum cable routing can be achieved for nearly all frame types.

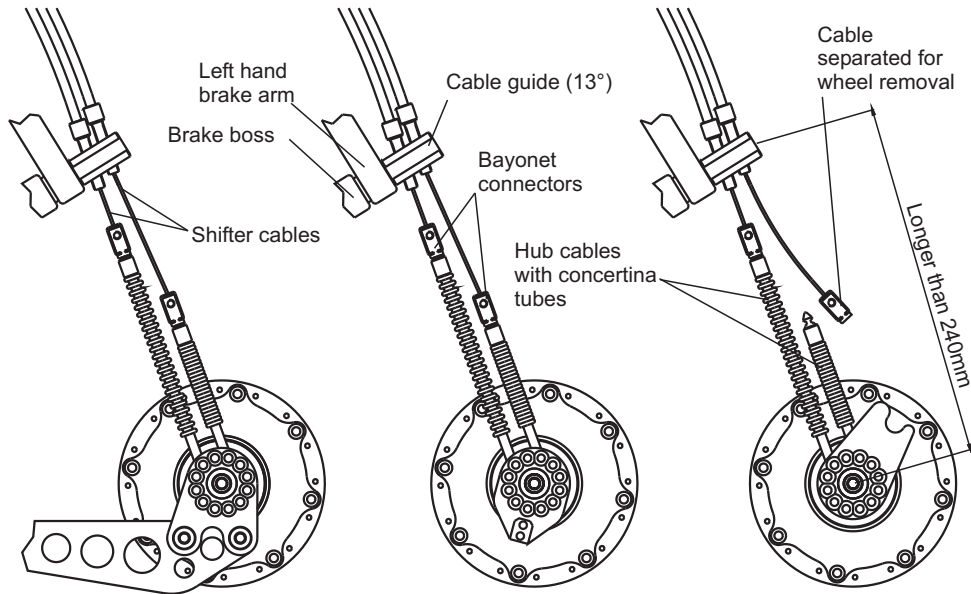

The diagrams show examples of the internal gear mech routed via the brake boss with standard, OEM and OEM2 axle plates.

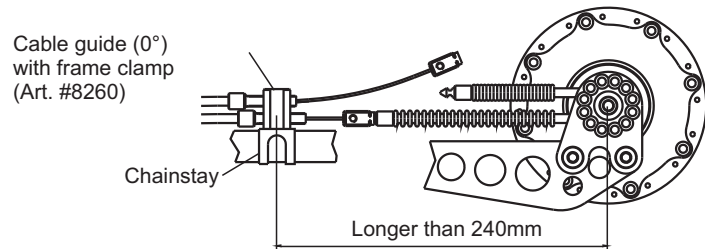

The diagram shows an example of the internal gear mech routed via the chainstay with the standard axle plate and long torque arm using the 0° cable guide and frame clamp.

External gear mech

With the external gear mech the shifter cables run directly from the twist shifter to the cable box. There is no separate cable stop necessary. For quick and easy removal of the rear wheel, the cable box can be removed from the external transfer box. All disc brake versions (DB) of the Rohloff SPEEDHUB 500/14 are equipped with the external gear mech. The hole pattern in the axle plate allows the adjustment of the gear mech in steps of 30°. Therefore, an optimum cable routing can be achieved for nearly all frame types.

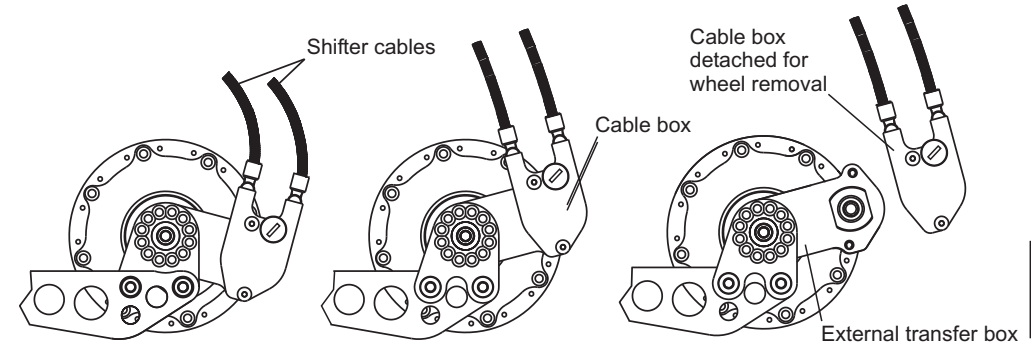

Mounting options with external gear mech and the standard axleplate with long torque arm

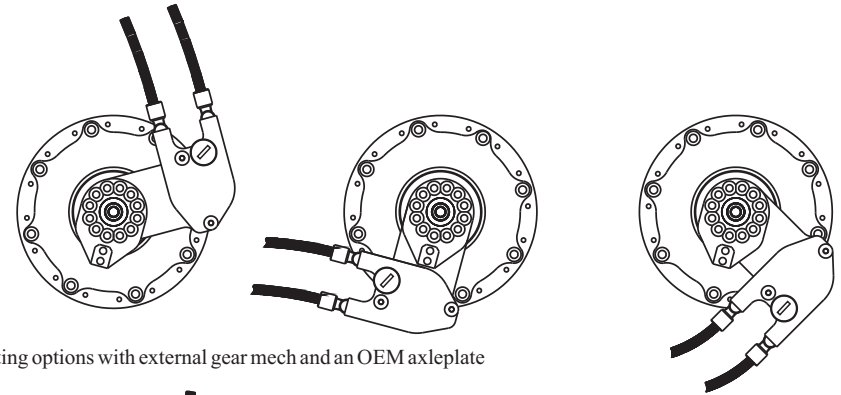

Mounting options with external gear mech and an OEM axleplate

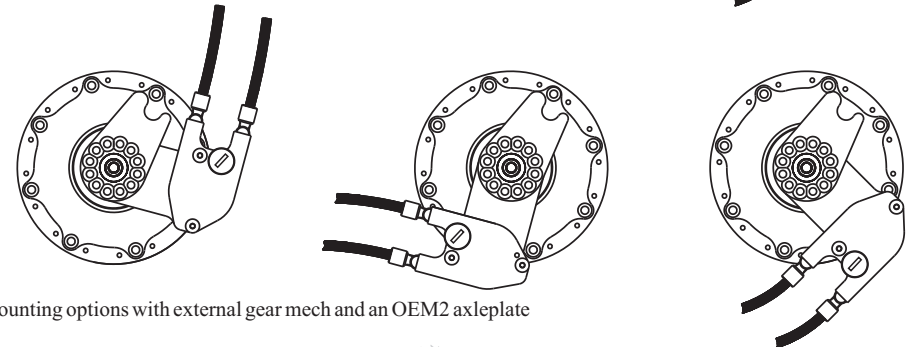

Mounting options with external gear mech and an OEM2 axleplate

Explaining the model codes

The first part of the model codes (CC/TS) refers to the axle type. Two different axle types are available:

- CC:** - Cross Country
Hollow axle for use with a quick release lever (quick release axle) (axle as shown in pictures 1 and 2*).
- TS:** - Threaded Spindle axle
Threaded axle with axle nuts M10x1 (axle as shown in picture 3*).
- A12:** - *Thru Axle frame compatible. Secured via 2x M7x1 bolts and special frame reduction sleeves inserted into the 12mm Thru axle dropouts.*
Dropout thickness test necessary using the special measurement kit - Art.#8600.

The following part of the model codes refers to additional hub specifications:

- EX:** - External gear mech
With external gear mech (gear mech as shown in pictures 2 and 3*).
- DB:** - Disc Brake
With a disc brake hub cap and external gear mech EX (hub cap and gear mech as shown in picture 2*).
- OEM:** - OEM version (Official Equipped Manufacturer)
With CC OEM or TS OEM axleplate according axle type only for frames with Rohloff OEM dropouts (axleplate as shown in picture 2*).
- OEM2:** - OEM2 version
With CC OEM2 or TS OEM2 axleplate according axle type for frames with international standard (IS1999) disc brake mounts (axleplate as shown in picture 3*).
- PM:** - PostMount version
Axleplate available for both CC and A12 axle types. Anchors the SPEEDHUB torque via a 'PM Bone' to the frames direct Postmount brake caliper mount.
- T:** - Tandem version.
With longer shifter cables (2.5m) for tandem or recumbent use.
- XL:** - Xtra Large - For frames with a 170/177mm spacing. Only available as a disc brake version finished in anodized black with 32 spoke holes.
- XXL:** - Xtra Xtra Large - For frames with a 190/197mm spacing. Only available as a disc brake version, finished in anodized black with 32 spoke holes.

All Rohloff SPEEDHUB 500/14 versions are available in three different colors:

- Silver:** - anodized (polished aluminum up to 10/2013)
- Red:** - anodized
- Black:** - anodized

* see next page

The Rohloff SPEEDHUB 500/14 is available in different versions in accordance to the individual requirements. Pictures 1 to 3 show examples of three possible versions.

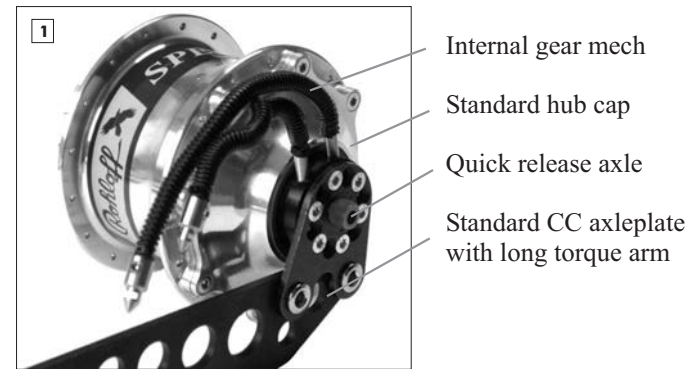

Rohloff SPEEDHUB 500/14 CC silver

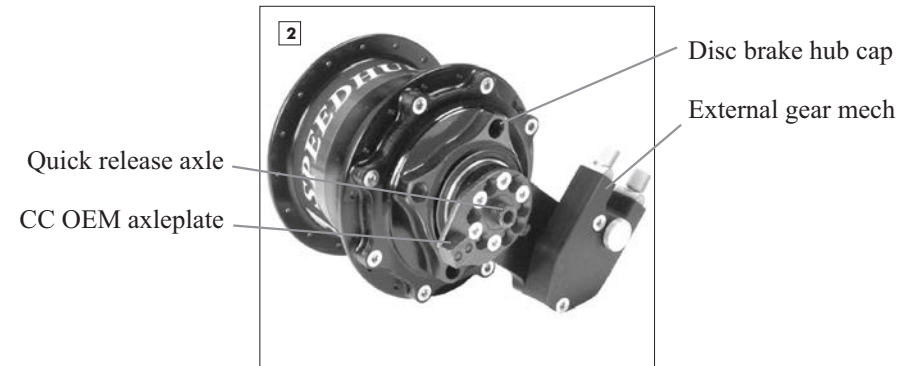

Rohloff SPEEDHUB 500/14 CC DB OEM black

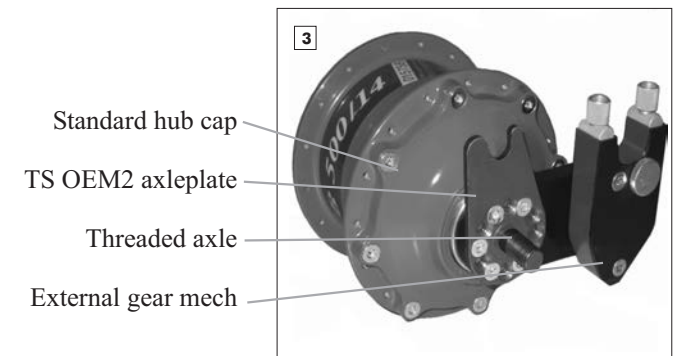

Rohloff SPEEDHUB 500/14 TS EX OEM2 red



Rohloff SPEEDHUB 500/14 CC mounted with a long torque arm



Rohloff SPEEDHUB 500/14 CC OEM mounted in a frame with adjustable Rohloff OEM dropouts



Rohloff SPEEDHUB 500/14 CC OEM2 mounted with the support bolt



Rohloff SPEEDHUB 500/14 CC DB OEM2 mounted with the Rohloff SPEEDBONE and a disc brake



Rohloff SPEEDHUB 500/14 A12 DB PM mounted with the Rohloff PM BONE (PM-PM Adapter) and a PM disc brake



Rohloff SPEEDHUB 500/14 TS DB OEM2 mounted with the Rohloff MONKEY BONE (IS-PM Adapter) and a IS 2000 disc brake



Rohloff SPEEDHUB 500/14 XXL A12 DB OEM2 mounted with the Rohloff FAT BONE and a disc brake

Rohloff SPEEDHUB 500/14 with a disc brake

The mounting of the *Rohloff SPEEDHUB 500/14* with the use of a disc brake requires a frame with disc brake mounts of international standard (IS1999) or Direct Postmount Standard. The hubs are available with the choice of axle, quick release (CC DB versions) or threaded axle (TS DB versions) or with 12mm reduction sleeves and M7 bolts (A12 DB versions). The particulars of the DB versions are:

- 1) The hub cap includes a center disc mount. It is on this side that the external gear mech is also to be found. Normal 6-bolt brake discs of international standard are not mountable, a special 4-bolt *Rohloff* disc with only four securing holes for bolts M8x0.75 must be fitted due to the large diameter of the hub seal. *Rohloff* offers a range of discs from 160mm to 203mm for nearly every type of disc brake currently on the market. More details are to be found on the web under www.rohloff.de > FAQ > SPEEDHUB > disc brake
- 2) The disc brake versions of the *Rohloff SPEEDHUB 500/14* are only available with the external gear mech, because the brake disc/caliper could interfere with the hub cables of the internal gear mech.

The interchangeable parts system allows the conversion of any *Rohloff SPEEDHUB 500/14* to a disc brake version (DB versions). The conversion of a hub to a DB version can only be carried out by the *Rohloff* service department.

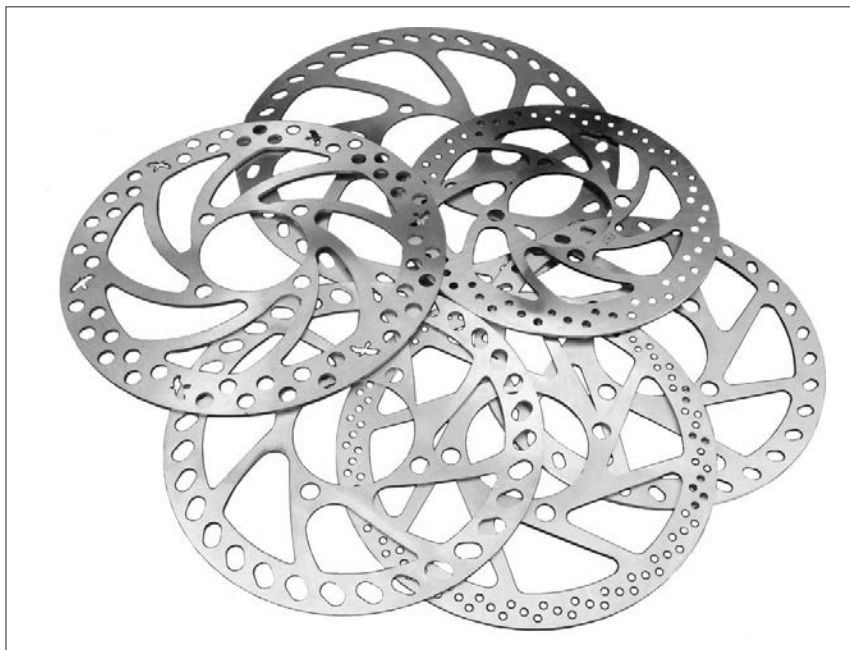

Rohloff 4-hole discs

Advantages of the separate options**Threaded axle TS**

The *Rohloff SPEEDHUB 500/14* versions with a threaded axle are required for frames with horizontal dropout slots. It is, however, also possible to mount this hub in dropouts with vertical slots. For downhill riders the possibility of using a more secure TS threaded axle will increase rear wheel stability much like a thru axle.

Quick release axle CC

The *Rohloff SPEEDHUB 500/14* versions with quick release axles are exclusively for use on frames with vertical dropout slots. They allow for a quick removal/installation of the wheel without the need for tools.

Thru axle compatible system A12

The *Rohloff SPEEDHUB 500/14* Versions with an A12 axle are specifically designed to fit 12mm thru axle frames. The use of special adapter sleeves (available for DT/Maxle, Syntace, Shimano thru axle styles) enable these SPEEDHUBs to be retrofitted to a great number of current production frames.

Internal gear mech

The internal gear mech is on all *Rohloff SPEEDHUB 500/14* versions with the exception of EX and DB models. It requires a minimum distance of 240mm between the axle and the cable guide mounting point. To prevent the possibility of the bayonet connectors coming into contact with the brake disc, a combination of disc brake and internal gear mech is not available. The internal gear mech model is the lightest of the two gear mech versions with the *Rohloff SPEEDHUB 500/14* CC weighing approx. 1700g.

External gear mech EX

The models with an external gear mech allow the shifter cables to run uninterrupted from the twist shifter to the cable box, so the need for a separate cable stop is also eliminated. Because of this, the external gear mech is especially useful for frames with a short chainstay length (20" wheels) or uncommon rear triangles.

The external gear mech is approx. 100g heavier than the internal gear mech, but, therefore, more robust as no separate hub cables are in use. Should a shift cable should break, this system allows the user to select any gear from the outside of the external transfer box making this especially useful for the everyday and the touring rider.

The disc brake versions (DB) of the *Rohloff SPEEDHUB 500/14* are equipped with the external gear mech as the hub cables of the internal gear mech would come into contact with the brake disc.

OEM

The *Rohloff SPEEDHUB 500/14* OEM versions require the use of *Rohloff* OEM dropouts where the left hand dropout slot is elongated to house the support block of the OEM axle plate. Hardtail frames with adjustable *Rohloff* OEM dropouts, eliminate the need for a chain tensioner and chain guide thus offering a cleaner, tidier aesthetic and a higher level of functional safety, ideal for extreme riding situations.

OEM2

The OEM2 axleplate uses the frames lower disc brake mounting hole to prevent the axle from turning (torque anchor). The OEM2 axleplate offers a cleaner, tidier aesthetic to the system. Only compatible with international standard (IS 1999) mount or when a specially drilled hole is present. An OEM2 axleplate uses the disc brake mount to secure the torque of the hub. Therefore, permission must be obtained from the frame manufacturer to ensure that frame warranty is not affected.

PM

The use of a PM axleplate in combination with a PM Bone enables the *SPEEDHUB 500/14* models to be retrofitted to frames with an integrated Postmount brake mount. The *SPEEDHUB* torque is anchored to the frame directly via the brake mount.

XL/XXL

XL versions are specially lengthened hubs designed for frames with a 170/177mm (XXL = 190/197mm spacing). These hubs enable fatbikes the opportunity to run a strong, symmetrically laced *SPEEDHUB* with the fattest tires available. XL Versions (CC/TS/A12) are only available as disc brake versions with 32 spoke holes, finished in anodized black. XXL Versions (CC/A12) are only available as disc brake versions with 32 spoke holes, finished in anodized black.



Model variations

For a better summary of what comes with each model, below is a list of the model variations and the parts included in the respective package.

Rohloff SPEEDHUB 500/14 CC (silver Art. #8000, red Art. #8001, black Art. #8002)

Contents: Hub with quick release axle, twist shifter, cables, quick release parts, long torque arm and a chain tensioner.

Rohloff SPEEDHUB 500/14 CC OEM (silver Art. #8005, red Art. #8006, black Art. #8007)

Contents: Hub with quick release axle, twist shifter, cables and a CC OEM axle plate for torque support.

Rohloff SPEEDHUB 500/14 CC EX (silver Art. #8010, red Art. #8011, black Art. #8012)

Contents: Hub with quick release axle, twist shifter, cables, quick release parts, external gear mech, CC axle plate with long torque arm and a chain tensioner.

Rohloff SPEEDHUB 500/14 CC EX OEM (silver Art. #8015, red Art. #8016, black Art. #8017)

Contents: Hub with quick release axle, twist shifter, external gear mech, cables and a CC OEM axle plate for torque support.

Rohloff SPEEDHUB 500/14 CC DB (silver Art. #8020, red Art. #8021, black Art. #8022)

Contents: Hub with quick release axle, hub cap with mounting for Rohloff special brake discs (compatible with IS1999), external gear mech, cables, twist shifter, chain tensioner, quick release parts and a CC axle plate with a long torque arm.

Rohloff SPEEDHUB 500/14 CC DB OEM (silver Art. #8025, red Art. #8026, black Art. #8027)

Contents: Hub with quick release axle, hub cap with mounting for Rohloff special brake discs (compatible with IS1999), external gear mech, cables, twist shifter and a CC OEM axle plate for torque support.

Rohloff SPEEDHUB 500/14 TS (silver Art. #8040, red Art. #8041, black Art. #8042)

Contents: Hub with threaded axle, twist shifter, cables and a TS axle plate with long torque arm.

Rohloff SPEEDHUB 500/14 TS OEM (silver Art. #8045, red Art. #8046, black Art. #8047)

Contents: Hub with threaded axle, twist shifter, cables and a TS OEM axle plate for torque support.

Rohloff SPEEDHUB 500/14 TS EX (silver Art. #8050, red Art. #8051, black Art. #052)

Contents: Hub with threaded axle, twist shifter, cables, external gear mech and a TS axle plate with long torque arm.

Rohloff SPEEDHUB 500/14 TS EX OEM (silver Art. #8055, red Art. #8056, black Art. #8057)

Contents: Hub with threaded axle, twist shifter, cables, external gear mech and a TS OEM axle plate for torque support.

Rohloff SPEEDHUB 500/14 TS DB (silver Art. #8060, red Art. #8061, black Art. #8062)

Contents: Hub with threaded axle, hub cap with mounting for Rohloff special brake discs (compatible with IS1999), twist shifter, cables, external gear mech and a TS axle plate with long torque arm.

Rohloff SPEEDHUB 500/14 TS DB OEM (silver Art. #8065, red Art. #8066, black Art. #8067)

Contents: Hub with threaded axle, hub cap with mounting for Rohloff special brake discs (compatible with IS1999), twist shifter, cables, external gear mech and a TS OEM axle plate for torque support.



All 135mm O.L.D. models are available as both 32 & 36-spoke versions and/or tandem versions with cables of 2.5m in length. The 36 spoke versions receive an additional number '6' before the article number. Tandem hubs receive the letter 'T' after the article number (e.g. 68025 or 8025T).

Upgradable/additional parts that can be ordered:

CC OEM2 axle plate (Art. #8227)

TS OEM2 axle plate (Art. #8228)

CC PM axleplate (Art. #8225)

Chain tensioner (Art. #8250)

Chain guide CC (Art. #8290)

Rohloff SPEEDBONE (Art. #8550)

Monkey Bone IS-PM Adapter (160mm = Art. #8553 / 180mm = Art. #8554)

PM Bone (Art. #8555)

Sprocket (13 tooth) (Art. #8219)

Sprocket (15 tooth) (Art. #8220)

Sprocket (17 tooth) (Art. #8222)

Splined sprockets: 13t-Art.#8541, 14t-Art.#8542, 15t-Art.#8543, 16t-Art.#8544, 17t-Art.#8545, 18t-Art.#8546, 19t-Art.#8547, 21t-Art.#8549

Downhill-Kit (Art. #8293) consisting of:

DH chain tensioner (Art. #8245)

DH chain guide (Art. #8291)

(also available separately)

Cable guide 0° (straight) type with frame clamp (Art. #8260)

DD spokes (2.0/1.8/2.0mm) spoke bend length 2.9mm for 26"-wheels.

Spokes between 228mm and 244mm in increments of 2mm.

Rohloff special 4-hole brake discs for the corresponding brake type.



When ordering the *Rohloff SPEEDHUB 500/14* variation needed, it is necessary to pay attention to which additional parts are needed to mount the *Rohloff SPEEDHUB 500/14* to the bike. Example: *Rohloff* chain tensioner, *Rohloff SPEEDBONE*, *Monkey Bone*, spokes in the correct length and the correct *Rohloff* special brake disc for the brake type in use.

These include for example:

- *Rohloff* chain tensioner,

- *Rohloff SPEEDBONE* / *MonkeyBone* / *PM Bone*

- spokes in the correct length,

- the correct *Rohloff* special brake disc for the brake type in use,

- *Rohloff* Chain guide for either CC or DH,

- Cable guide 0° with frame clamp,

- Long chain tensioner bolt for use with the 13 tooth threaded Sprocket,

- TS axle plate 'long', for use in conjunction with a trailer mount from the company Weber, Pitlocks, or stands which are mounted directly on the axle.

- Flange Support Rings



Wheel stability

When the Rohloff SPEEDHUB 500/14 is built up into a 32/36 spoke wheel, it is considerably more robust than the common 36 spoke wheels. The stability is approx. the same as a 48 spoke tandem wheel.

The spoke flanges of the Rohloff SPEEDHUB 500/14 are built symmetrically. This allows the spokes to be at the same angle on both sides of the finished wheel, this in turn leads to a much stronger wheel due to the evenly distributed spoke tension.

To build up a strong wheel, the spokes must be tensioned to a **minimum 1000N**. The spoke tension on the cassette side of normal derailleur hubs, is considerably higher (over 1200N) due to the dishd way the wheel must be laced. This can also lead to problems with the nipple seat of the rim (see MTB comparison below, the pretension in the 9-speed cassette here is reduced to just 600N).

Due to the increased diameter of the hub flanges used by the Rohloff SPEEDHUB 500/14, spokes laced in a two-cross pattern enter the rim at roughly the same angle as a three-cross lacing pattern on smaller flanged hubs. There is less load on the spokes because of the large spoke hole PCD. The spokes pull further away from the axle center, therefore the hub flange has a better lever to pull the wheel around (torque = force x lever length).

The comparison below shows the maximum spoke loads. The numbers in brackets are the pretensioned min. force of the spokes after lacing, truing and tensioning with an inflated tire (tire pressure 60p.s.i.):

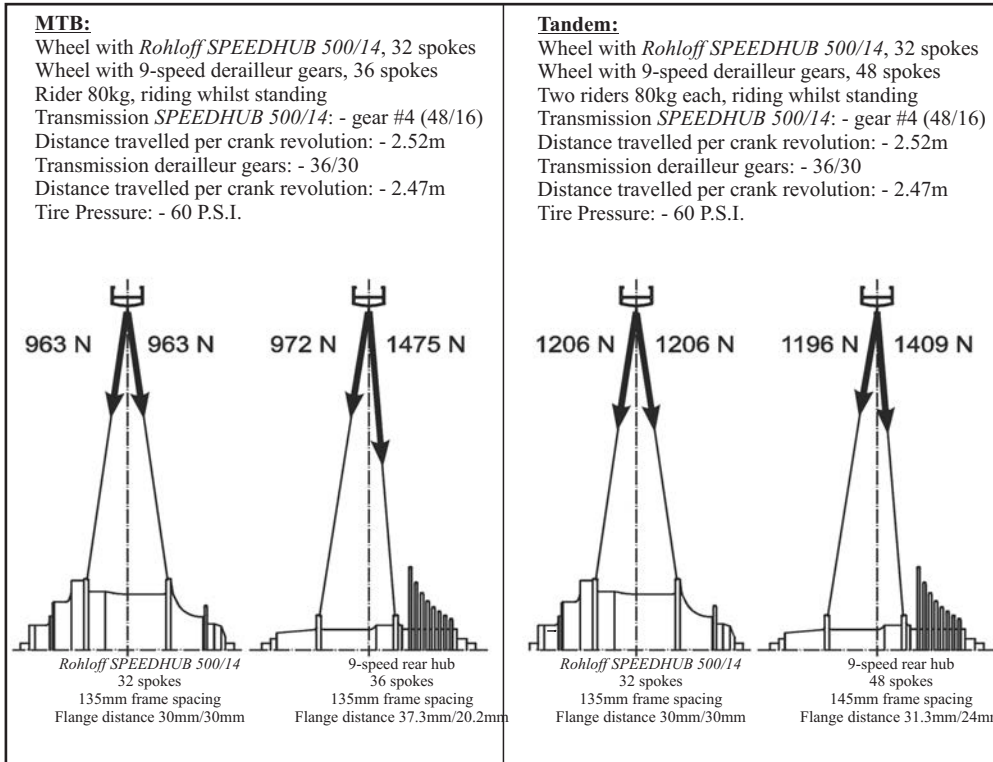

The figures for the 9-speed tandem wheel are better than those of the solo MTB wheel due to the fact that the spokes are not at so steep of an angle and there are 48 of them regardless that there are two riders on the tandem. But even here, the Rohloff SPEEDHUB 500/14 wheel with 1206N against 1409N is the better option.

Spoke lengths 32/36 spoke hole rims

The Rohloff SPEEDHUB 500/14 uses a spoke hole circle diameter of 100mm with 2.7mm diameter spoke holes (2.5mm up until Serial No.44321). When lacing the Rohloff SPEEDHUB 500/14 into a **26" wheel**, the spoke sizes required will usually prove fairly difficult to find in the average bike shop. For this reason silver 'Sapim Race' spokes 2.0/1.8/2.0mm with Polyax 12mm nipples are available from Rohloff in lengths of 228mm to 244mm. The most commonly used spoke length (for 26" wheels) of 238mm is also available in black. Below is a table showing the required spoke lengths for 32/36 spoke rims. Due to the symmetrical hub flanges of the SPEEDHUB 500/14, the spokes are the same length on both sides of the wheel:

32-Loch Gehäuse Speichenlänge
32-hole Hub-shell Spoke lengths

Laufradgröße / Wheel Size	Anzahl Kreuzungen / Number of Spoke Crosses	ERD*	Speichenlänge / 32-hole Spoke lengths		
18"	1-X	341-343	128		
		344	130		
20"	1-X	372-373	142		
		374-377	144		
		378-381	146		
		382-385	148		
		386-389	150		
		390-394	152		
24"	1-X	472-476	192		
		477-480	194		
		481-484	196		
		485-489	198		
		490-493	200		
		494-497	202		
		498-501	204		
		502-503	206		
		26"	2-X	516-519	226
				520-523	228
524-527	230				
528-531	232				
532-535	234				
536-539	236				
540-543	238				
544-547	240				
548-551	242				
552-555	244				
556-559	246				
560-563	248				
564-567	250				
568-571	252				
572-575	254				
576-579	256				
580-583	258				
28"	2-X			584-587	260
		588-592	262		
		593-596	264		
		597-600	266		
		601-604	268		
		605-608	270		
29"	2-X	609-612	272		
		613-616	274		
		617-620	276		
		621-624	278		
		625-628	280		
		629-632	282		

empfohlene Größe / recommended rim size

36-Loch Gehäuse Speichenlänge
36-hole Hub-shell Spoke lengths

Laufradgröße / Wheel Size	Anzahl Kreuzungen / Number of Spoke Crosses	ERD*	Speichenlänge / 36-hole Spoke lengths
18"	1-X	341-342	126
		343-344	128
20"	1-X	372-375	142
		376-379	144
		380-383	146
		384-387	148
		388-392	150
		393-396	152
24"	1-X	472-474	190
		475-478	192
		479-482	194
		483-486	196
		487-490	198
		491-494	200
26"	2-X	495-498	202
		499-502	204
		503	206
		516-517	222
		518-522	224
		523-526	226
		527-530	228
		531-534	230
		535-538	232
		539-542	234
650B	2-X	543-546	236
		547-550	238
		551-554	240
		555-558	242
		559-562	244
		563-566	246
		567-570	248
		571-574	250
		575-578	252
		579-582	254
28"	2-X	583-586	256
		587-590	258
		591-594	260
		595-598	262
		599-602	264
		603-607	266
29"	2-X	608-611	268
		612-615	270
		616-619	272
		620-623	274
		624-627	276
		628-631	278

On wheel sizes 26" and 28" the wheel must always be laced in a two cross pattern. Therefore, the table above shows the spoke lengths for a two cross lacing pattern. On wheel sizes 24" and under, the spokes must only be laced in a one cross lacing pattern. For this reason, the table above shows the spoke lengths for a one cross lacing pattern.

A constantly updated list of spoke lengths can be found on the internet under www.rohloff.de.

A spoke length calculator can also be found on our homepage to help work out other correct lengths of spokes that may be required (www.rohloff.de/en/technical/speedhub/spoke_lengths/index.html).



ATTENTION !

Nipple eyelets are currently being reduced in size to save as much heavy steel as possible in the construction. In cases such as these, the nipple is however hindered from aligning itself correctly for lacing large flange hubs and this results in a small kink in the spoke where it joins the nipple. This will lead to premature spoke failures at the kink.

For this reason, rims should be used where the rim eyelet has an inner diameter of at least 4.4mm, or if possible, rims should be used which are angularly drilled.

Laufradgröße / Wheel Size	Anzahl Kreuzungen / Number of Spoke Crosses	ERD*	32-Loch Speichenlänge / 32-hole Spoke lengths 7mm Offset	32-Loch Speichenlänge / 32-hole Spoke lengths 12.5mm Offset	32-Loch Speichenlänge / 32-hole Spoke lengths 20mm Offset
26"	2-X	516-519	228	226	226
		520-523	230	228	228
		524-527	232	230	230
		528-531	234	232	232
		532-535	236	234	234
		536-539	238	236	236
540-543	240	238	238		
544-547	242	240	240		

Calculating the spoke length (32 + 36):

The formula below can be used to calculate the correct spoke length should your rim ERD not listed in the table.

Spoke length:
$$L = \sqrt{(0.25 \times d^2) + 3400 - (50 \times d \times c)}$$

d: effective rim diameter in mm

c = 0.924 with 1 cross pattern (32 hole) c = 0.707 with 2 cross pattern (32 hole)

c = 0.940 with 1 cross pattern (36 hole) c = 0.770 with 2 cross pattern (36 hole)

Calculation example with 32 spokes:

Effective rim diameter: d = 539mm; 2 cross pattern: c = 0,707

Spoke length:
$$L = \sqrt{(0.25 \times 539^2) + 3400 - (50 \times 539 \times 0.707)}$$

L = 238,69mm (always round up/down to the nearest even number. Here: 238mm)

ATTENTION !

It is not permitted to radially lace wheels built with a Rohloff SPEEDHUB 500/14, because the drive force is delivered through this wheel.

Due to the large spoke hole circle diameter of the Rohloff SPEEDHUB 500/14, the entrance angle between the spokes and the rim is considerably small. All 26" and 28" wheels must not be built in more than a 2x lacing pattern. All wheels smaller than 26" (24" and under) are only permitted to be laced in a 1x pattern.

Determining the effective rim diameter (ERD)

Should the effective rim diameter need to be measured because the rim was not listed in the previous table, the following steps can be used to determine this:

- Measure the head height **K** of the spoke nipples that are intended for use.
- Measure the spoke length **S** from beginning of the thread to the inside of the 90° bend.
- Thread a spoke through the rim and screw the nipple onto this so that the end of the spoke is level with the head of the spoke nipple.
- Place a second spoke through the spoke hole of the opposing side of the rim and screw the nipple onto this spoke in the same way.
- Pull these two spokes together and measure the distance **X**.

The effective rim diameter can now be determined using the formula: $d = 2 \times S + X - 2 \times K$

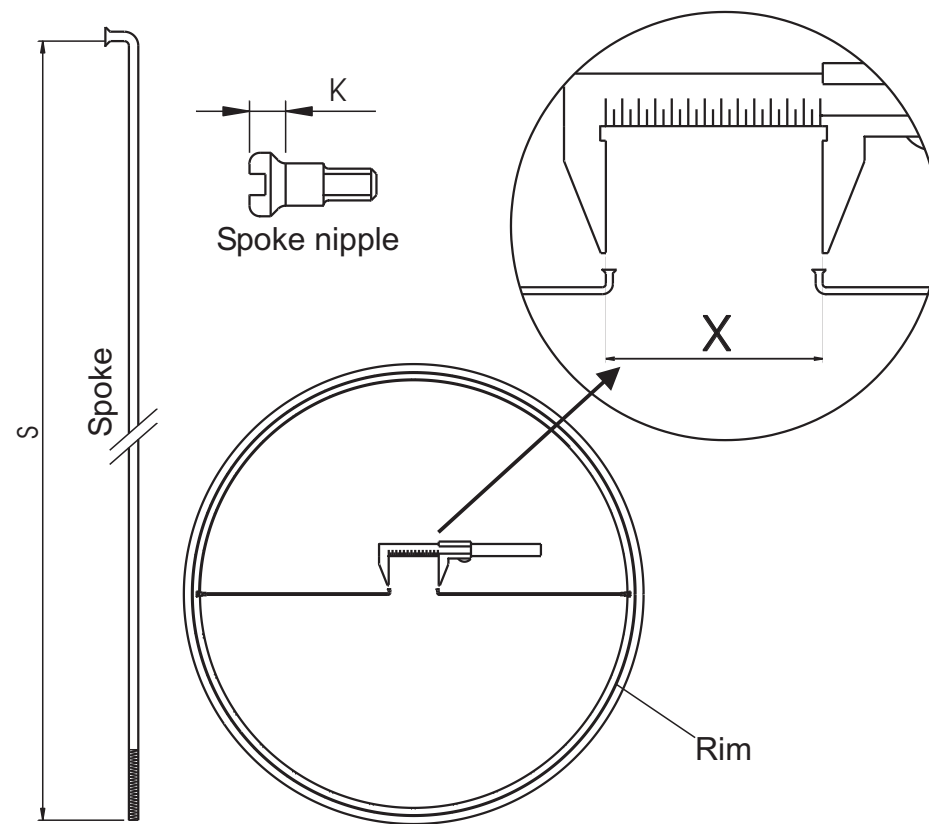

Which components are recommended?

Chains:

All 8 (1/2"x3/32") speed and 9 (1/2"x11/128") speed chains are compatible with *Rohloff SPEEDHUB 500/14* sprockets. 1/2"x1/8" chains can also be used with all *Rohloff SPEEDHUB 500/14* sprockets however although these thicker chains may be slightly stronger, they do not offer any improvement regarding durability or lifespan and are therefore not recommended for use with the *Rohloff SPEEDHUB 500/14*. In addition, these 1/2"x1/8" chains are incompatible with the *Rohloff* chain tensioner due to their width. When using a 15 tooth sprocket, it is important to make sure that the chain does not measure more than 8.5mm in height (over the joint), otherwise it is possible that rub/wear marks could appear on the hub shell.



Chain rings:

All derailleur gear chainrings can be used for the *Rohloff SPEEDHUB 500/14*.

It is important to check the concentricity of the mounted chainring when utilizing an eccentric BB or adjustable dropouts so that the tension of the chain is correct in all crank positions.

Cranks (chain line):

The use of sprockets 15, 16 or 17 teeth on the *Rohloff SPEEDHUB 500/14* require a chain line of approx. 54mm from the frame center. This needs the use of the outer chainring from triple cranksets such as standard Shimano (Largest chainring: 54mm, middle chainring 47.5mm). The middle and smallest chainrings are usable. After the disassembly of the middle and smallest chainrings, the bolts for securing the largest chainring are now too long, because they are now only securing one chainring to the crank. For this reason the *Rohloff SPEEDHUB 500/14* small parts bag includes five chainring spacers to distance the original bolts. For retrofitting with double chainring cranksets, the outer chainring should definitely be used.

Reversible sprocket with 15, 16 and 17 teeth (Art. #8220, #8221 and #8222)

The *Rohloff SPEEDHUB 500/14* comes fitted with a 16 tooth sprocket. 15 and 17 tooth reversible sprockets are available as alternatives. Hereby, an individual sprocket/chainring combination can be applied (see "Technical data" - "chainrings"). The 15, 16 and 17 tooth sprockets are reversible, and therefore, can be used from both drive sides. For sprocket removal, a special *Rohloff* sprocket removal tool (Art. #8501) is needed. When using a 15 tooth sprocket, it is important to make sure that the chain does not measure more than 8.5mm in height (over the joint), otherwise it is possible that rub/wear marks could appear on the hub shell.

Sprocket with 13 teeth (Art. #8219)

For the use of the *Rohloff SPEEDHUB 500/14* on small wheeled bicycles (e.g. 20" folding bikes and recumbants) the special 13 tooth sprocket is needed. It uses a different chain line (58mm instead of 54mm) and is not reversible. When using a *Rohloff* chain tensioner on frames with dropouts thinner than 7mm, the longer chain tensioner mounting bolt (Art. #8255) must be separately ordered. For sprocket removal, a special *Rohloff* sprocket removal tool (Art. #8501) is needed.

Rohloff chain tensioner (Art. #8250)

Mounting a chain tensioner is necessary on frame types A, C, D, E and G (see "frame types"), because the chain is not tensionable by simply sliding the wheel within the dropouts. The chain tensioner is just as necessary on frames with rear suspension, this is because the distance between the chainring and sprocket varies as the rear suspension is activated. The span capacity of the *Rohloff* chain tensioner is 10 links or 20 teeth. The use of the *Rohloff* chain tensioner also requires the use of a chain guide up front.

Rohloff DH chain tensioner (Art. #8245)

The *Rohloff DH* chain tensioner is specially designed for extreme downhill use. As opposed to the regular *Rohloff* chain tensioner it has a shorter link arm that is not able to swing on the mounting point. This keeps the chain securely in position against the sprocket, guaranteeing a positive run from the chain onto the sprocket even in extreme riding conditions. The use of the *Rohloff DH* chain tensioner also requires the use of a chain guide up front.

Rohloff chain guide CC (Art. #8290)

The *Rohloff* chain guide CC prevents the chain from springing off the chainring on all bikes fitted with a chain tensioner. The *Rohloff* chain guide is adjustable depending on the chain line (distance between chainring and frame center) between 52mm and 62mm. The chain springing off the chainring in extreme riding conditions is not preventable by a chain tensioner alone.

Rohloff DH chain guide (Art. #8291)

The *Rohloff DH* chain guide is specially designed for extreme downhill use. It eliminates the chain from falling off the sprocket and onto the hub casing which could happen in extreme riding conditions.

Rims

The *Rohloff SPEEDHUB 500/14* is only available in a 32/36 spoke version. The ideal rims to be used are triple hollow aluminum rims from known manufacturers with reinforced spoke eyelets (min. 4,4mm) or alternatively, rims which are diagonally drilled or with countersunk nipple seats (e.g. ANDRA, Taurus, GRIZZLY and EDGE 7 from Rigida/Ryde or the Ex19 rim from Exal).

Spokes/nipples

Because the spokes have a large say over the stability of the overall wheel, exclusive quality spokes from well known manufacturers should be used. Double thickness spokes (2,0-1,8-2,0mm) from DT-Swiss and Sapim (with spoke bend length BL 2,9mm) are good examples. When applying a lot of force on the wheel (pannier bags, tandem use, extreme use), the spokes should be fitted with self-locking spoke nipples (lock nipples) during the wheelbuilding process. This reduces the risk of the spokes loosening whilst riding. On rims without reinforced nipple holes, only spoke nipples with rounded heads should be used (Sapim Polymax or DT swiss Prohead), this spreads the spoke tension evenly through the nipple head against the rim.

Quick release lever

The CC versions of the *Rohloff SPEEDHUB 500/14* are supplied with a hollow Q/R axle to secure the hub to the frame. To be sure that the hub is correctly secured into the frame, it is advisable to use a Q/R lever with a steel skewer. The use of lightweight Q/R levers with aluminium or titanium skewers is at the riders own risk! Make sure that the maximum 7Nm closure torque is not exceeded when using a Pitlick or other Q/R systems!

Racing handlebars

The twist shifter of the *Rohloff SPEEDHUB 500/14* can only be used on straight handlebars with a diameter of 22.2mm and, therefore, is not compatible with regular racing handlebars. Special racing bars (eg racing bars from the firm Norwid (www.norwid.de) or Van Nicholas (www.van-nicholas.com) allow the mounting of the twist shifter. Further information can be found in the FAQs under www.rohloff.de. Another alternative is a special separable twist shifter for racing handlebars. Gilles Bertoud (www.gillesberthoud.fr) and Co-Motion cycles (www.co-motion.com) both produce such shifters. Further information over this can be found on our homepage in the FAQ section.

Use of a rear disc brake

The *Rohloff SPEEDHUB 500/14* DB versions are equipped with an external gear mech and a special hub cap for the mounting of a brake disc. Only brake discs with a *Rohloff* mounting hole diameter of 65mm and a center hole diameter of 52mm can be used. Information about the various brake discs currently available can be found on the web under www.rohloff.de.

Axle plates

The various axle plates are all available separately, and therefore, making it easy to change any version of the *Rohloff SPEEDHUB 500/14* over to a different method of torque support. When a longer axle thread (TS) is required, simply add an "L" to the Art. No.

Axle plate CC	(Art. #8232)	Axle plate TS	(Art. #8233)	-long	(Art. #8233L)
Axle plate CC OEM	(Art. #8234)	Axle plate TS OEM	(Art. #8235)	-long	(Art. #8235L)
Axle plate CC OEM2	(Art. #8227)	Axle plate TS OEM2	(Art. #8228)	-long	(Art. #8228L)
Axle plate CC PM	(Art. #8225)				

The CC/TS OEM axle plates are also available as stronger **tandem versions (T)** with only one mounting option.

Rohloff Speedbone (Art. #8550) or IS-PM Adapter MonkeyBone (160mm Art. #8553 / 180mm Art. #8554)

The *Rohloff Speedbone* is an adapter that allows bikes that are fitted with disc brakes to also use the OEM2 method of torque support. The *Rohloff Speedbone* is compatible with all disc brake types of international standard (IS 1999). The *Speedbone* is required when using an IS brake caliper with an IS frame. IS frames using PM brake calipers can use either a *Speedbone* (Art. #8550) or *Monkeybone* (160mm = Art. #8553 / 180mm = Art. #8554).

Gear mech

The external gear mech (Art. #8213) and the internal gear mech (Art. #8572) can be ordered separately. This allows an easy change of the gear mech.

Particulars

Rohloff SPEEDHUB 500/14 on tandems

All versions of the *Rohloff SPEEDHUB 500/14* are available for tandem use (assuming that the frame spacing is 135mm). The **typical coding of a tandem version is the letter "T"** (eg CC-T or TS EX-T). The *Rohloff SPEEDHUB 500/14* tandem versions come with shifter cables of 2.5m in length. The number of spoke holes is still 32 or 36 (see wheel stability). For stability reasons the use of double butted DD spokes 2.0/1.8/2.0mm is recommended.

The correct spoke lengths for 26" wheels are readily available from Rohloff dealers. Spokes for 28" are available from a number of quality manufacturers (Sapim/DT Swiss):

Small wheels

Wheels with a smaller diameter than 26" should only use a one cross lacing pattern, because this helps to keep the spoke at the correct angle against the rim. Radial lacing of the *Rohloff SPEEDHUB 500/14* is not permitted. The *Rohloff SPEEDHUB 500/14* should not be laced into a wheel smaller than 18" in diameter, because, due to the hubs large flange diameter, the spokes would enter the rim at a too acute of an angle.

Halfstep

Through the use of two chainrings with a size difference of approx. 7% (racing cranksets with 39 and 34 tooth chainrings) the change in gear ratio increases could reduce from 13.6% by approx. half. This additional feature is interesting for road racing applications.

Usage of two chainrings

In extreme riding conditions, where the use of a greater gear range is necessary, it is possible to use the *Rohloff SPEEDHUB 500/14* in conjunction with two chainrings. This increases the number of actual gears by about two. When applying this feature, make sure that there is a difference of approx. 13% between chainring sizes for one additional gear and approx 29% for two additional gears (eg 50/39 chainrings).

Using the Schlumpf/Haberstock "Speed-drive" or the "High Speed drive"

The Haberstock Schlumpf Speed-drive/High Speed drive works like two chainrings with a large difference in size. With the additional transmission of 1:1.65 or 1:2.5 the gear ratio of the *Rohloff SPEEDHUB 500/14* used in conjunction with the Haberstock/Schlumpf Speed-drive will be increased to 868% or 1315%. It is still important not to undercut the smallest permitted sprocket ratios (see "sprocket ratios").

The Haberstock/Schlumpf Mountain-drive is not permitted for use with the *Rohloff SPEEDHUB 500/14*.

Using the *Rohloff SPEEDHUB 500/14* as an intermediate frame mounted gear-unit

Should the *Rohloff SPEEDHUB 500/14* be mounted within the frame itself, the smallest permitted sprocket ratios from the cranks to the gearbox must not be undercut (see 'sprocket ratios'). Sprockets used for the transmission from the gearbox to the rear wheel can be of any size.

Using a Bicycle trailer in conjunction with the *Rohloff SPEEDHUB 500/14*

The use of a trailer mount in conjunction with the *Rohloff SPEEDHUB 500/14* is normally not a problem! However, the problem could arise with different types of trailer models where the long torque arm (when in use) must be carefully adapted. In case of queries please refer back to the manufacturer of the bicycle trailer to find out if they have any experience or special adapters for the mounting in conjunction with the *Rohloff SPEEDHUB 500/14*. Alternately refer to www.rohloff.de - FAQ > SPEEDHUB > TRAILER.

Using an axle mounted bicycle stand with the *Rohloff SPEEDHUB 500/14*

A bicycle stand which is mounted directly on the rear axle of the *Rohloff SPEEDHUB 500/14* is available from the company Point bike innovation GmbH, phone 0049 2206 95800. (Bicycle stand Cd93 black, adjustable for 26" - 28"). The SPEEDHUB axleplate "TS long" with the longer thread should be used together with this sort of bicycle stand.

www.rohloff.de > FAQ > SPEEDHUB > TORQUE SUPPORT > AXLE PLATES.



Particulars

Use of an enclosed chainguard.

The chainguard **must not** rub against the hub shell. This rubbing effect could result in deep brush marks appearing upon the hub shell, possibly eventually wearing completely through it! This damage could lead to accidents through oil leakage or even a complete blockage of the gear unit itself.

Sprockets used with on a bicycle fitted with a 'Hebie Chainglider' may not be reversed. The Chainglider uses the exposed seal surface to support itself. This use may have caused damage or wear which would lead to excessive oil loss if then rotated and used as a seal surface.

Use of a carbon handlebar in conjunction with the *Rohloff* shifter

The *Rohloff* Shifter (Art. #8200) is not approved for installation on any sort of carbon handlebar. **The Rohloff AG will not be held responsible for accidents resulting from the mounting of the *Rohloff* shifter on carbon handlebars.**

The *Rohloff* Shifter (Art. #8206 / 8207) is approved for carbon handlebar use.

Eccentric BB or adjustable dropouts on frames with the *Rohloff SPEEDHUB*

It is especially important to use a concentric mounted chainring when utilizing an eccentric BB or adjustable dropouts, otherwise the chain tension could vary extremely. The chain tension should be set so that the chain has approximately 10mm play when lightly pushed from underneath and under no pressure.

If using adjustable dropouts in collaboration with the internal gear mech, then it is important to check that there is enough room for the cable adjusters to accommodate the moving of the rear wheel as the chain wears/stretches. (if not, the housing may have to be shortened).

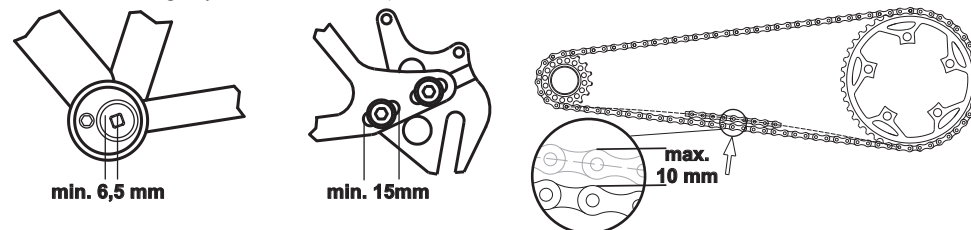

Use of Tuning parts

http://www.rohloff.de/en/technology/tuning_parts/index.html

Belt drive transmission system 'Gates Carbondrive':

When utilizing a bicycle equipped with a 'Gates Carbondrive' belt transmission, it is important to adhere to the manufacturers instructions printed within their owners manual. Further information can be obtained from: www.gatescarbdrive.com/resources/manuals-and-tech

'MonkeyBone' IS to PM adapter:

Compatible with the OEM2 axleplate in combination with a Postmount disc brake caliper.

160mm disc = Art. #8553 / 180mm disc = Art. #8554

'PM Bone' (PM-PM Adapter) + 'PM Axleplate':

The *Rohloff* PM Axleplate (PM CC Art. #8225) in combination with the PM Bone (Art. #8555) is recommended when mounting a SPEEDHUB in all frames with an integrated Postmount direct calliper mount.

Further information over these parts and many others is available on our Homepage under: www.rohloff.de/en/service/download/documentation

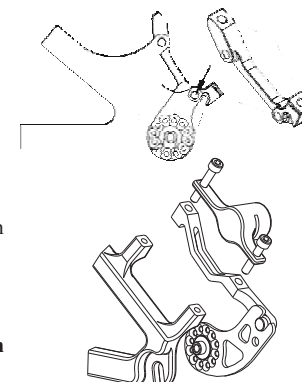

Mounting

The following sequences are useful for the mounting of the *Rohloff SPEEDHUB 500/14*

1. Package contents

1.1	Checking the package contents	51
1.2	Checking the contents of the small parts bag	53

2. The wheel

Wheelbuilding	55
---------------------	----

3. Mounting additional parts (according to the version)

3.1	Standard long torque arm	56
3.2	Crankset	57
3.3	<i>Rohloff</i> DH chain guide (accessory for downhill)	58
3.4	OEM2 mounting with a support bolt	59
3.5	OEM2 mounting with <i>SPEEDBONE / MonkeyBone</i>	59
3.6	Brake discs	60

4. Cable routing and axle plate alignment

4.1.1	Internal gear mech via brake boss	61
4.1.2	Internal gear mech via chainstay	62
4.2.1	External gear mech OEM/OEM2	63
4.2.2	External gear mech with long torque arm	63
4.3	Axle plate alignment	64

5. Mounting the wheel

5.1.1	<i>Rohloff SPEEDHUB 500/14</i> with a long torque arm	
	Mounting (CC versions)	65
	Mounting (TS versions)	66
5.1.2	<i>Rohloff SPEEDHUB 500/14</i> with an OEM axle plate	67
5.1.3	<i>Rohloff SPEEDHUB 500/14</i> with an OEM2 axle plate	67
5.2	Chain tensioner	
5.2.1	<i>Rohloff</i> chain tensioner	68
5.2.2	<i>Rohloff</i> DH chain tensioner (accessory for downhill)	69
5.3	The chain	
5.3.1	Mounting with a chain tensioner	70
5.3.2	Mounting without a chain tensioner	70
5.4	<i>Rohloff</i> chain guide CC	71

6. Twist shifter

Mounting of the twist shifter	73
-------------------------------------	----

7. Cable routing

7.1	Shifter cables	75
7.2.	Internal gear mech	
7.2.1	Cable routing via the brake boss	76
7.2.2	Cable routing via the chainstay	79
7.3	External gear mech	
7.3.1	Cable routing via the chainstay	80
7.3.2	Cable routing via the top tube	83
7.4	Adjusting the gear display	83

8. First oil fill

Filling with oil	84
------------------------	----

1.1 Checking the package contents



In the Rohloff SPEEDHUB 500/14 package will be:

- Rohloff SPEEDHUB 500/14 Handbook (Art. #8295)
- Rohloff SPEEDHUB 500/14 in the desired version **1**
- Bottle of Rohloff SPEEDHUB OIL 2
- Small parts bag **3**
- Two shifter cables consisting of bowden cable, cable housing **4**
- Twist shifter **5**
- Guarantee card **8**
- Oil fill reminder **9**

In the package could also be a long torque arm and/or a Rohloff chain tensioner. The following table shows in which Rohloff SPEEDHUB 500/14 package these could be found.

	CC	CC OEM	CC DB	CC DB OEM	CC EX	CC EX OEM	TS	TS OEM	TS DB	TS DB OEM	TS EX	TS EX OEM
Long torque arm 6	●	●	●	●	●	●	●	●	●	●	●	●
Chain tensioner 7	●	●	●	●	●	●						



8

9

1.2 Checking the contents of the small parts bag

There is a bag of small parts within the *Rohloff SPEEDHUB 500/14* package. These will be needed in order to mount the *Rohloff SPEEDHUB 500/14* to the bike itself. The contents of the bag depend upon which version of the *Rohloff SPEEDHUB 500/14* is contained within the package.



All the possible parts in this bag are shown with a number on the following side. Under that is a table showing which parts are to be found in the bag depending upon which version of the *Rohloff SPEEDHUB 500/14* is contained within the package.

Example:

***Rohloff SPEEDHUB 500/14* CC EX OEM:**

In this bag there will be eight cable housing caps (#12), five chainring washers (#17), an oil filling tube (#22) and an EX cable box (#23).

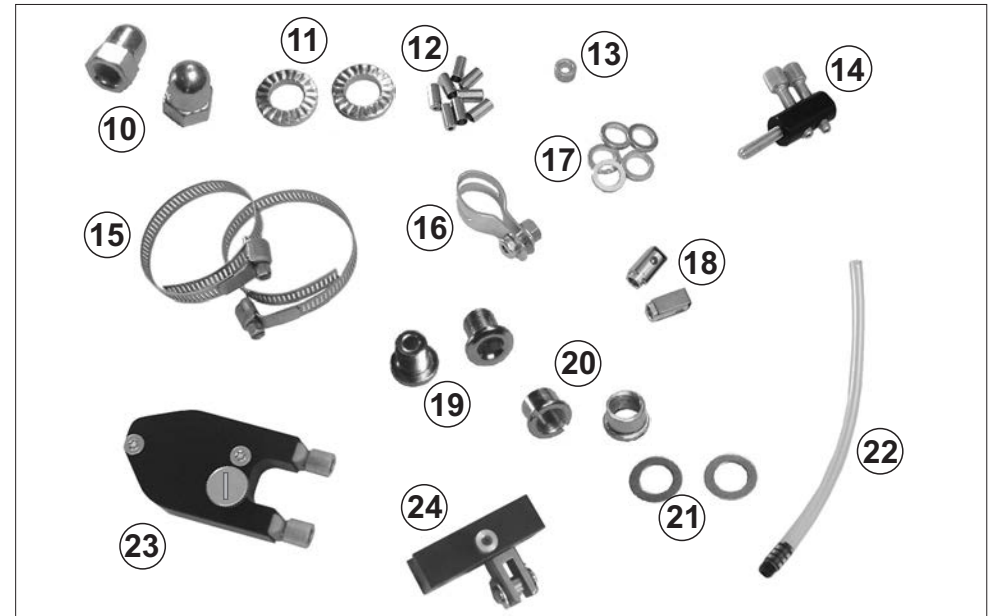

#	Parts	CC	CC OEM	CC DB	CC DB OEM	CC EX	CC EX OEM	TS	TS OEM	TS DB	TS DB OEM	TSEX	TSEX OEM
10	2 Axle nuts M10x1							●	●	●	●	●	●
11	2 Washers for the TS axle							●	●	●	●	●	●
12	8 Cable housing caps	●	●	●	●	●	●	●	●	●	●	●	●
13	1 Spacer 6,5x10x5,5 for the cable guide	●	●					●	●				
14	1 Cable guide 13° with adjusters & mounting bolt	●	●					●	●				
15	2 Clamps	●		●		●							
16	1 Torque arm clamp							●		●		●	
17	5 Chainring spacers	●	●	●	●	●	●	●	●	●	●	●	●
18	2 Female bayonet connectors	●	●					●	●				
19	2 Mounting bolts M8x0,75	●				●		●				●	
	4 Mounting bolts M8x0,75				●						●		
	6 Mounting bolts M8x0,75			●						●			
20	2 Threaded bushes M8x0,75	●				●		●		●		●	
21	2 Washers	●		●		●		●				●	
22	1 Oil filling tube	●	●	●	●	●	●	●	●	●	●	●	●
23	1 EX cable box			●	●	●	●			●	●	●	●
24	1 Quick release block & locating fork for torque arm	●		●		●							

2. The wheel

Wheel lacing

The number of times that the spokes are crossed over depends entirely upon the size of the rim.

All rims **larger than 24"** in diameter **must be laced in a two cross** pattern. All **24" and smaller sized** wheels must be laced **up in a one cross** pattern.

Due to the high torsional strength of the hub casing, the use of a reversed lacing pattern on the brake disk side (DB versions) is not necessary.

POINTER

Further detailed information with regards to wheel lacing and Spokeflangerings can be found in the Appendix.

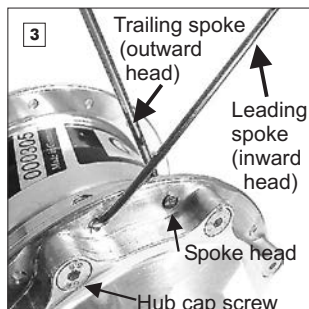

The leading spokes are laced so that the spoke head always faces inwards. The trailing spokes are laced so that the spoke head always faces outwards. All spokes should be crossed over each other.

ATTENTION

The wheel lacing method is determined by the nipple hole pattern. The correct lacing method for both types of hole pattern can be found in the appendix.

POINTER

Rotating the hub whilst wheelbuilding will be easier when the Rohloff SPEEDHUB 500/14 is in gear #11. This gear can be selected by pulling the hub cables (internal gear mech), or turning the hexagonal peg on the gear transfer box with an 8mm wrench (external gear mech).

Mounting

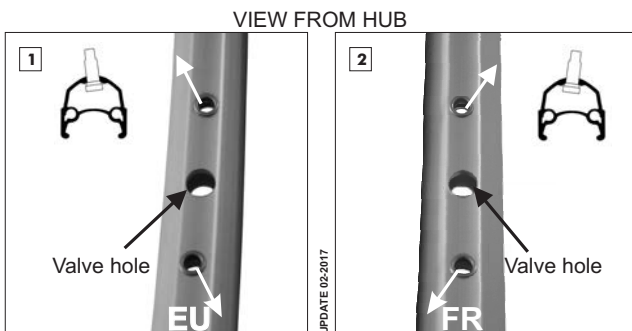

Rims are manufactured in different ways. The type of nipple hole pattern must be determined before lacing the wheel as this will require a different lacing method to be followed. In picture 1 the European nipple hole pattern (EU) is shown. The first spoke hole behind the valve hole lies to the direction of the left hand hub flange (pay attention to the rotational direction of the rim).

In picture 2 the French nipple hole pattern (FR) is shown. The first spoke hole behind the valve hole lies to the direction of the right hand hub flange (pay attention to the rotational direction of the rim).

If the spoke holes of the rim are all centrally drilled, then the lacing method for a European nipple hole pattern should be followed (see appendix).



Spokes must not cross directly over the hub cap fixing screws on wheels which are 24" or smaller in diameter!

Mounting

3. Mounting additional parts

The Rohloff SPEEDHUB 500/14 comes with additional parts according to the corresponding version. These parts must be mounted first.

3.1 Standard long torque arm

All Rohloff SPEEDHUB 500/14 versions not carrying the codes OEM or OEM2 come included with the long torque arm for supporting the torque. This must be mounted to the axle plate.

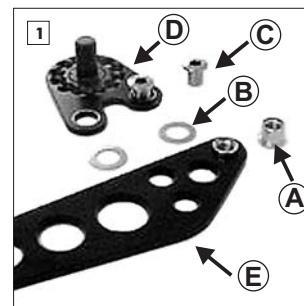

- A Threaded bush
- B Washer
- C Mounting bolt
- D Axle plate (CC or TS)
- E Long torque arm

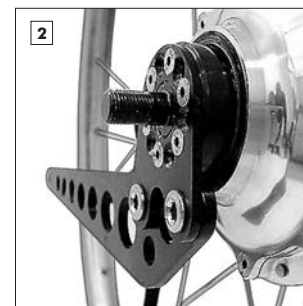

Push the threaded bushes through the torque arm from behind. Place a washer over each of the bushes and then the axle plate over these washers (pictures 1 and 2 show the TS version). Secure the two parts together with the mounting bolts. (M8x0.75 - 5mm allen key, tightening torque: 7Nm/61 in.lbs.).

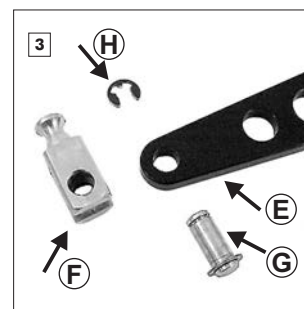

- F Locating fork
- G Securing pin with circlip
- H Circlip



On the CC versions, the locating fork must also be attached to the torque arm. Place the forked end over the torque arm, push the securing pin through the two parts and secure the other end in place with the circlip. TS Versions must have a torque arm clamp mounted instead of the locating fork.

ATTENTION

Make sure that both circlips sit correctly onto the securing pin.

3.2 Crankset

The Rohloff SPEEDHUB 500/14 requires a chainline of 54mm and with splined sprocket of 57mm. On bikes with three-ring cranksets, the middle chainring sits on a chainline of 47.5mm (measured from the frame center). The largest chainring has a chainline of 54mm. On most MTB and Trekking bike cranksets, the largest chainring and bottom bracket can normally be reused in conjunction with the Rohloff SPEEDHUB 500/14.

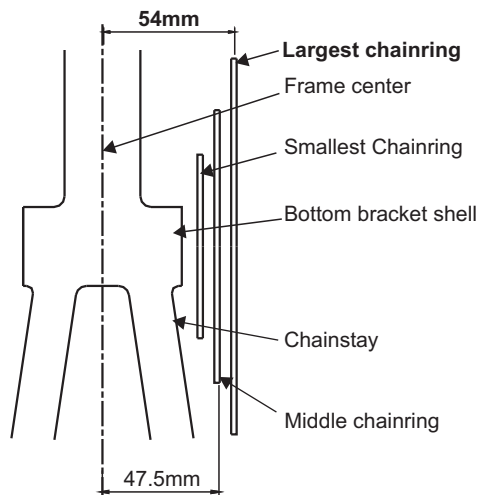

When disassembling the crankset for use with the Rohloff SPEEDHUB 500/14, the middle and smallest chainring will not need to be used, so they must be removed from the crankset. The chainring threaded bushes will be too long, because they are no longer securing two chainrings. For this reason there are five chainring spacers included in the small parts bag (to be found in every package). These should be placed over the threaded bushes before reassembling the crankset, so that the single chainring can be properly and tightly secured. (chainring bolts: 5mm allen key, lightly greased, tightening torque: 7Nm/61 in.lbs.).



3.3 Rohloff DH chain guide (accessory for downhill)

The Rohloff DH chain guide (Art. #8291) for the Rohloff SPEEDHUB 500/14 prevents the possibility of the chain springing off the sprocket and onto the hub casing under extreme riding conditions.

POINTER

The Rohloff DH chain guide can only be used in conjunction with a chainline of 54mm.

No to use with 13 teeth sprocket or splined sprockets with a 57mm chainline!

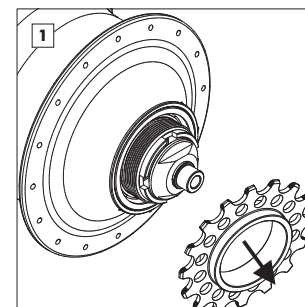

Remove the sprocket (see chapter "Service", paragraph 3. 'Sprocket reversing/replacing'). Clean the sprocket and regrease the thread.

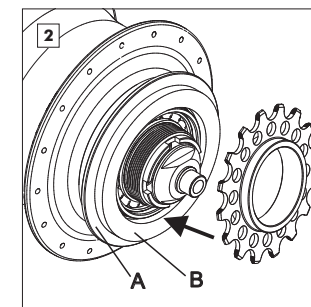

Place chain guide **A** and the mounting ring **B** onto the hub casing as shown above, screw the sprocket back on hand-tight. The mounting ring holds the DH chain guide the correct distance away from the sprocket.

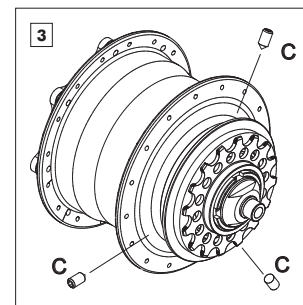

The three grub screws **C** (M4x8 - 2mm Allen key) should be screwed in evenly until they all touch the hub casing. Then tighten up all three screws in rotational order one complete turn at a time until they drill their way into the hub casing itself. During this process, the mounting ring will be trapped between the sprocket and the chain guide.

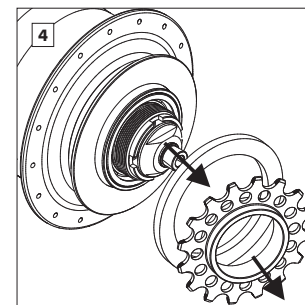

Unscrew each of the grub screws half a turn, this loosens the mounting ring so that the sprocket can now be removed. Make sure the pointed ends do not loosen out of the holes they drilled into the hub casing. Remove the mounting ring and tighten up all three grub screws $\frac{3}{4}$ of a turn.

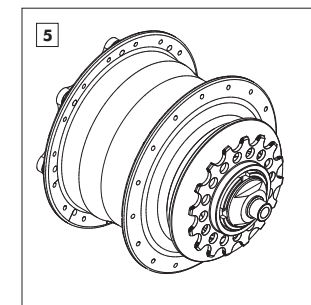

Lastly regrease the sprocket thread and screw the sprocket back onto the driver.

3.4 OEM2 mounting with a support bolt

The support bolt assembly for OEM2 mounting consists of a bolt (M6x16), a washer and a locknut. It is secured through the disc brake mounting hole of the dropout from the inside (tightening torque: 8Nm/71 in. lbs.).

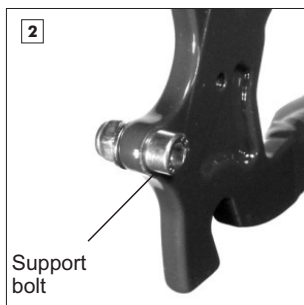
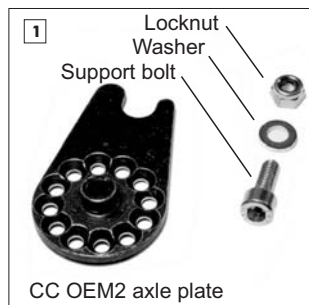

Mounted support bolt, view from inside the frame.

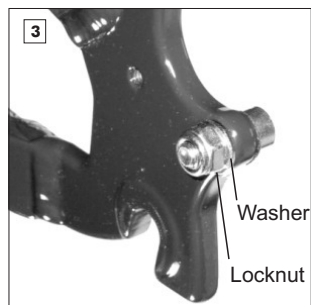

Mounted support bolt, view from outside the frame.

3.5 OEM2 mounting using a Rohloff SPEEDBONE

The Rohloff SPEEDBONE is mounted from the outer side of the frame and secured through the disc brake mounts into the brake caliper (paying attention to the brake manufacturers tightening torques). The original caliper securing bolts will be too short to mount through the Rohloff SPEEDBONE and should, therefore, be replaced by the long Rohloff SPEEDBONE securing bolts.



Rohloff SPEEDBONE (Art. #8550) with securing bolts.

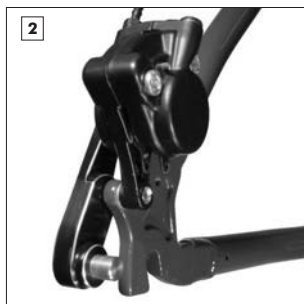

Mounted Rohloff SPEEDBONE, view from inside the frame.



Mounted Rohloff SPEEDBONE, view from outside the frame.

3.5 OEM2 Mounting using a MonkeyBone

The MonkeyBone (IS-PM Adapter) is secured to the inside of the disc-brake mounts on the dropout. The disc-brake caliper itself is then bolted down onto the MonkeyBone from above (uphold torque values from brake manufacturer). Not compatible with frames with disc brake caliper mounts positioned on the chainstays!

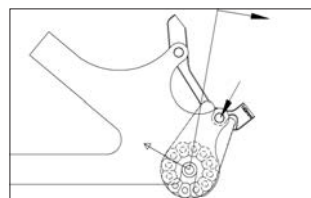

3.6 Brake discs

The Rohloff SPEEDHUB 500/14 uses a disc mount with a central diameter of 52mm and a stable four bolt mounting system which in turn has a diameter of 65mm. The special Rohloff brake disc must be additionally ordered.

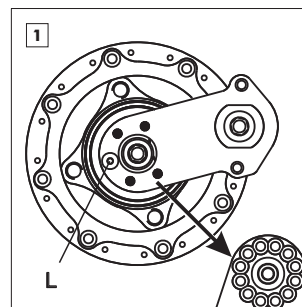

Remove the five axle plate screws (M4x25 - Torx TX20) along with the axle plate. Secure the external transfer box in place with one of these axle plate screws L.



The external transfer box should not be removed as the gears within could fall out of synchronisation. See chapter 'Service', paragraph 5. "Exchanging of the gear mech".

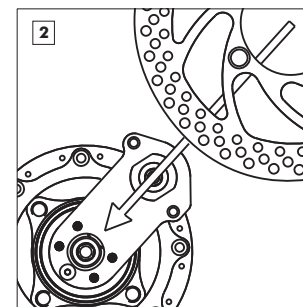
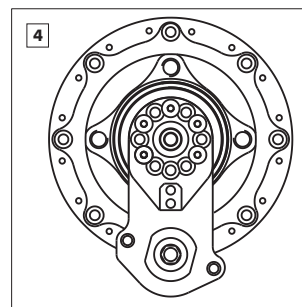

Place the brake disc over the external transfer box and locate over the center disc mounting. Pay close attention to the directional rotation of the brake disc!

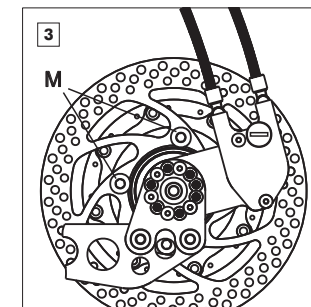

Place the four mounting bolts M into position and screw them in tightly (M8x0.75x8.5 - 5mm allen key, tightening torque: 10Nm/87"lbs). Remove the axle plate screw L from the external transfer box and then replace all five axle plate screws through the axle plate itself and secure them back tightly into the hub axle (M4x25 - Torx TX20, tightening torque: 3Nm/25"lbs).

On OEM versions, the removal of the axle plate is not necessary when the axle plate lies directly over the external transfer box (Pic 4). The brake disc can be mounted directly over these two components (fig. 5).

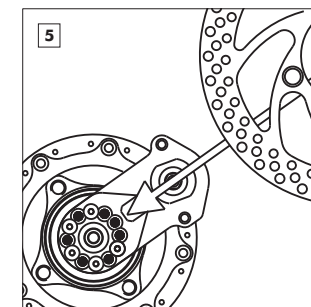

4. Cable routing and axle plate alignment

The alignment of the axle plate relies upon how the shifter cables are routed. The axle plate can be rotated in steps of 30° to find the optimum position for cable routing.

An optimum cable routing requires:

- less bending of the shifter cables
- the most direct route
- no kinks in the cables and housings

The following are examples of suitable cable routings. Of course, it is possible to select an alternative routing. To achieve this, however, the axle plate must be aligned accordingly.

4.1.1 Internal gear mech via brake boss

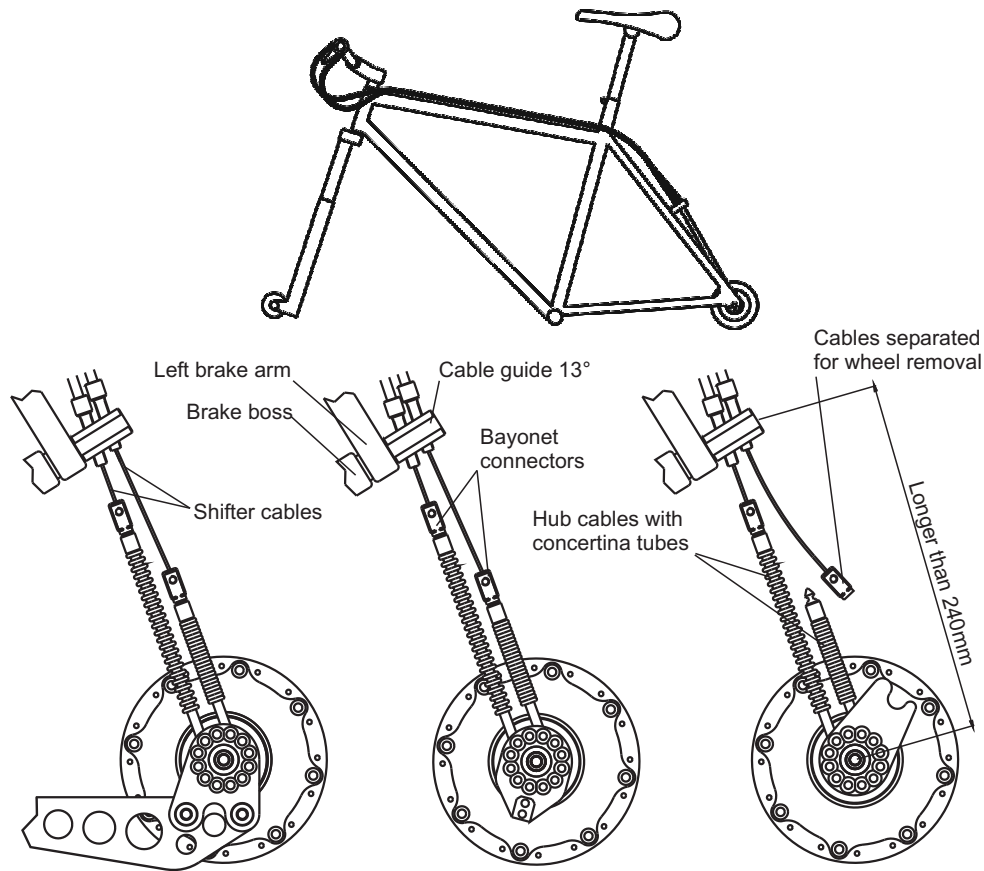

The diagrams show examples of the internal gear mech with the cable guide secured to the brake boss for the standard, the OEM and the OEM2 axle plates.

4.1.2 Internal gear mech via chainstay

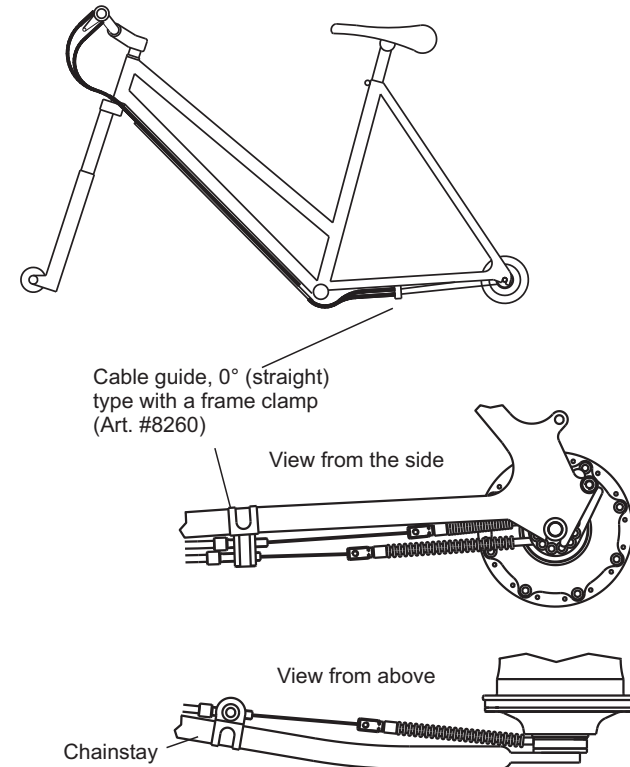

The diagrams show an example of the internal gear mech with the straight type cable guide secured to the chainstay.

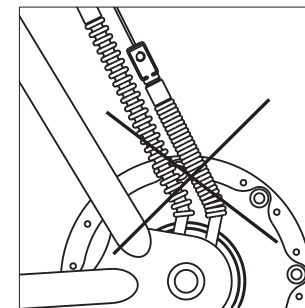

Incorrect axle plate alignment

ATTENTION

When aligning the axle plate, make sure that the hub cables run in the straightest line possible to limit the amount of rub and friction against the cable guides.

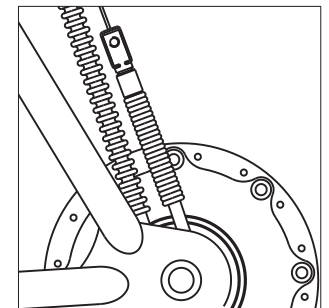

Correct axle plate alignment

4.2.1 External gear mech OEM/OEM2

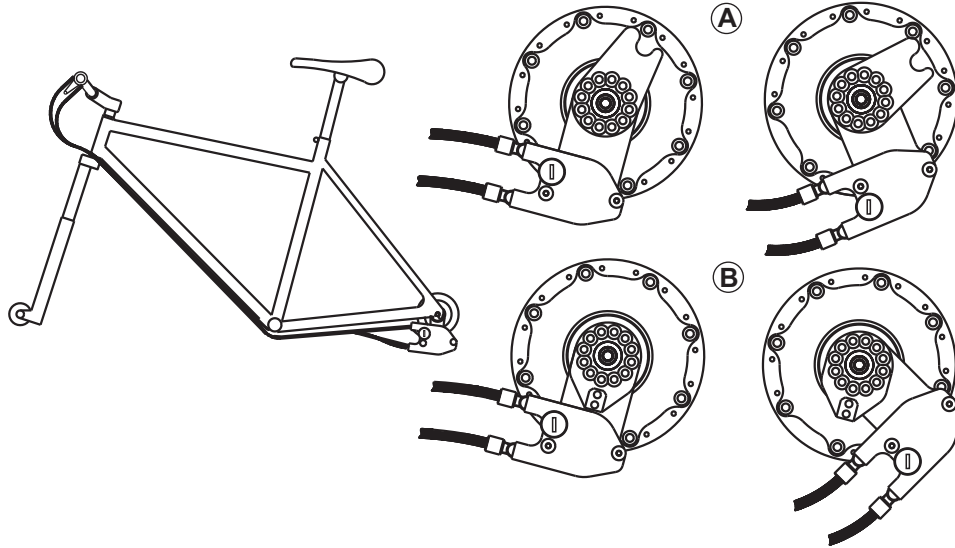

The diagrams above show the external gear mech with the cable routing via the chainstay for use with the OEM2 axle plate **A** and the OEM axle plate **B**.

4.2.2 External gear mech with long torque arm

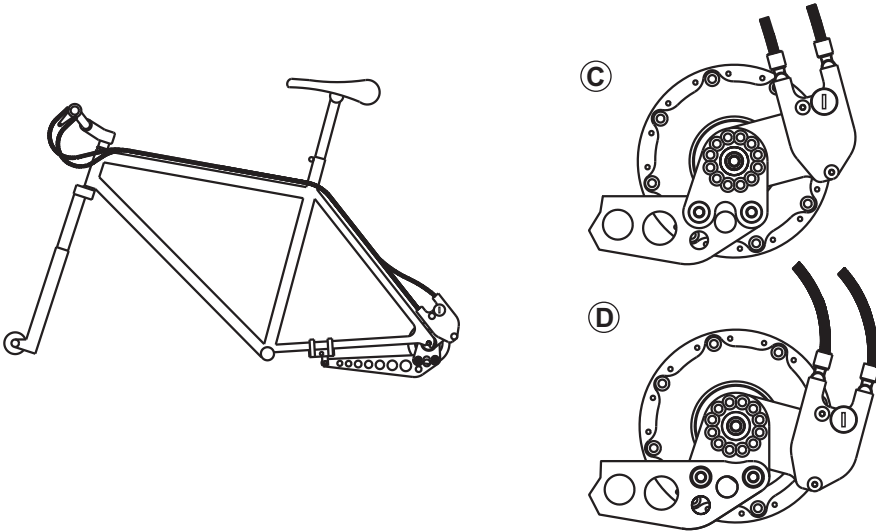

The diagrams above show the external gear mech in combination with the standard axle plate and the long torque arm. When the external transfer box needs to be in the position shown in diagram **D**, then the axle plate must be secured to the inside of the long torque arm.

4.3 Aligning of the axle plate

To align (rotate) the axle plate, all axle plate screws (M4x25, Torx TX20) must first be removed. Rotate the axle plate into the desired position and then reinsert the axle plate screws through the axle plate into the hub axle. Secure them tightly (tightening torque: 3Nm/25in.lbs.).

To hold the axle in position (when removing the axle plate screws), use a 10mm wrench on the OEM and OEM2 versions or simply hold the long torque arm tightly on the standard axle plate versions (see fig. 1-3 below).

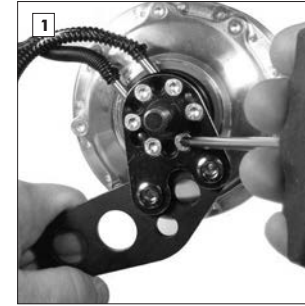

Standard axle plate with long torque arm: Hold the torque arm tightly while loosening/tightening the axle plate screws.

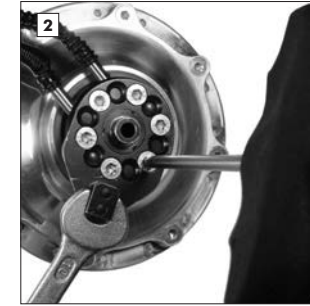

OEM axle plate: Hold the support block with a 10mm wrench while loosening/tightening the axle plate screws.

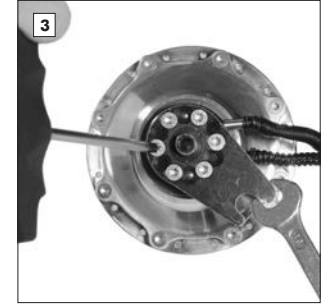

OEM2 axle plate: Hold the fork leg carefully with a 10mm wrench while loosening/tightening the axle plate screws.

5. Mounting the wheel

5.1.1 Rohloff SPEEDHUB 500/14 with long torque arm

Mounting (CC versions)

The Rohloff SPEEDHUB 500/14 CC versions are equipped with a quick release block for the long torque arm to enable a quick wheel removal. The quick release block must be secured to the chainstay.

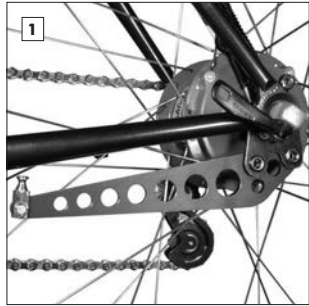

Place the rear wheel into the dropouts and rotate the axle, so that the long torque arm sits just underneath the chainstay. Close the quick release lever.



Bend the long torque arm sideways until the small end sits directly underneath the chainstay.

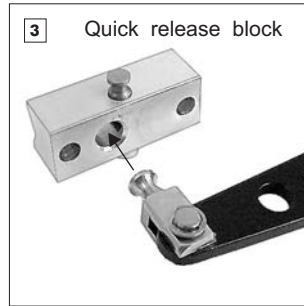

Insert the locating fork into the quick release block and push the quick release pin in. To ease this process, pull the torque arm down, away from the chainstay.

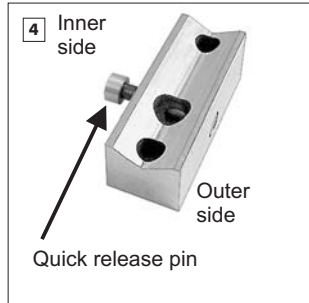

Closed position: The quick release pin is flush with the outer side of the quick release block (Fig. 5). To open: Push the quick release pin from the inner side.

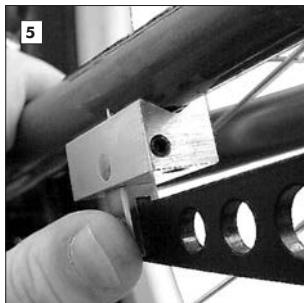

Push the long torque arm with the attached quick release block against the underside of the chain stay. The protruding side of the quick release pin must face inwards. With the axle quick release lever closed, check that the quick release block sits directly under the chainstay. If not, bend the torque arm into the correct position.

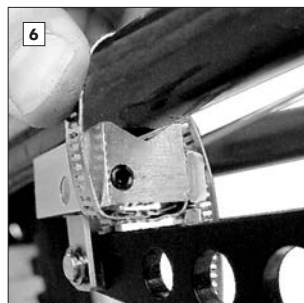

Both clamps should be bent around the chainstay into position as shown in the picture above. The securing bolts of the clamps must sit on the inside of the frame facing downwards.



Remove the clamps and (using wire cutters) trim them to the correct length. Small photo: Remove the sharp edges (Risk of injury).

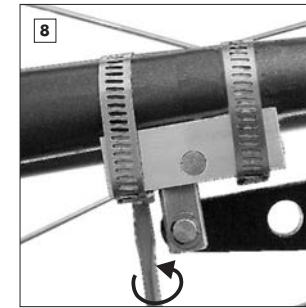

Fit both clamps and tighten the securing bolts evenly (tightening torque: 2.5Nm/21,5in.lbs.).

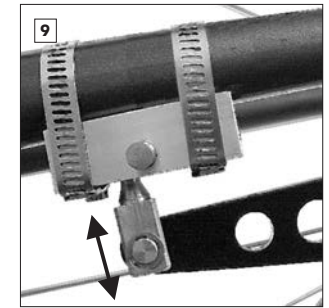

Open the quick release pin and the axle quick release lever, check that the locating fork can be easily swung in and out of the quick release block. If not, the clamps must be loosened and quick release block relocated accordingly.

Mounting (TS versions)

The Rohloff SPEEDHUB 500/14 TS versions are equipped with a frame clamp for the long torque arm. This consists of a metal clamp, nut, bolt and washer.

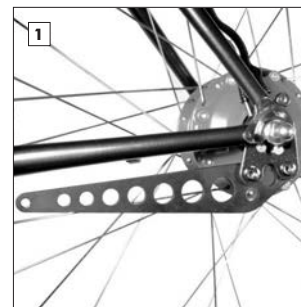

Place the rear wheel into the dropouts and rotate the axle, so that the long torque arm sits just underneath the chainstay. Tighten the axle nuts.



Bend the long torque arm sideways until the end sits directly underneath the chainstay.

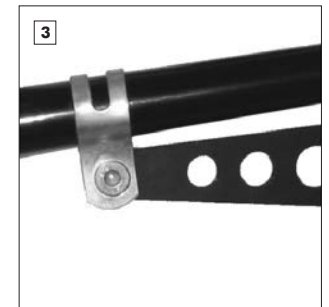

Place the metal clamp over the chainstay and secure to the end of the long torque arm with the supplied bolt. (10mm wrench and 4mm allen key - tightening torque: 6Nm/51in.lbs.).

5.1.2 Rohloff SPEEDHUB 500/14 with OEM axle plate

When mounting the wheel, the axle peg must be inserted into the long dropout slot first, followed by the support block. Before closing the quick release lever (CC versions) or tightening the axle nuts (TS versions), check that both axle pegs are sitting correctly within the dropout slots.

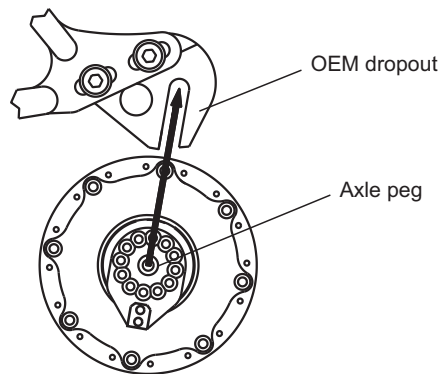

5.1.3 Rohloff SPEEDHUB 500/14 with OEM2 axle plate

When mounting the wheel, the OEM2 axle plate seat must locate itself around the support bolt or the support peg of the Rohloff SPEEDBONE / MonkeyBone. Before closing the quick release lever (CC versions) or tightening the axle nuts (TS versions), check that both axle pegs are sitting correctly within the dropout slots and that the axle plate seat sits correctly around the support bolt or peg of the Speedbone/MonkeyBone.

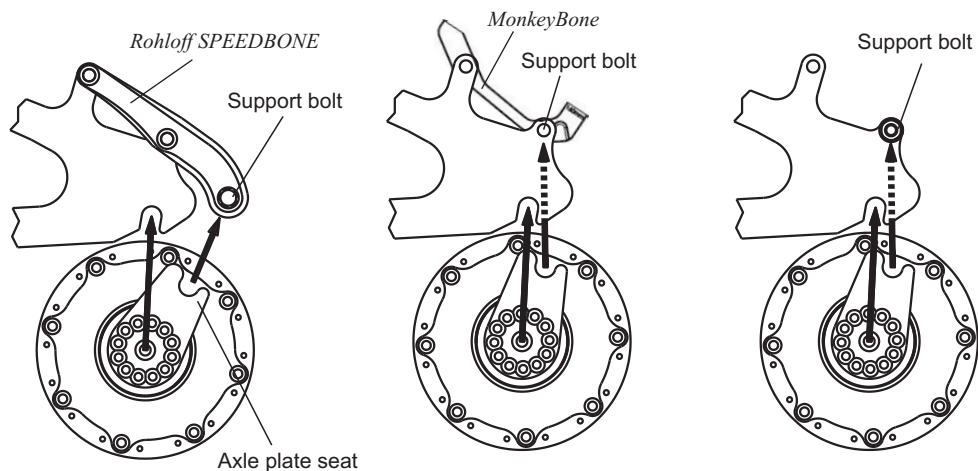

5.2 Chain tensioner

5.2.1 Rohloff chain tensioner (Art. #8250)

The Rohloff chain tensioner has a tension capacity of 10 chain links. It is mounted to the derailleur hanger. The appropriate chainline is adjusted by the use of the supplied washers.

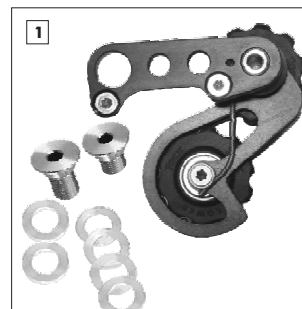

The Rohloff chain tensioner comes with one short and one long mounting bolt and four distancing washers (4 x 1mm, 2 x 3mm). With the distancing washers, it is possible to distance the Rohloff chain tensioner 1mm to 10mm away from the frame.

Dropout Thickness	Threaded sprockets 15-17 & 21		Splined sprockets 13-19 + 21.
	Chainline 54mm	Chainline 58mm	Threaded sprocket 13. Chainline 58mm
A [mm]	B [mm]	B [mm]	B [mm]
4	6	10	
5	5	9	
6	4	8	
7	3	7	
8	2	6	
9	1	5	
10	0	4	

The table shows the required distance B to be filled by distancing washers in relation to the dropout thickness and the chainline used. When mounting the Rohloff chain tensioner in this correct distance from the dropout, it is guaranteed that the jockey wheels sit directly underneath the sprocket.

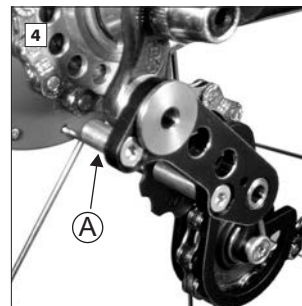
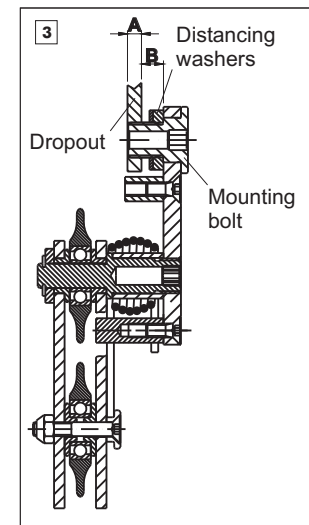

Secure the Rohloff chain tensioner, so that the end stop peg A sits against the back of the gear hanger. (5mm allen key, tightening torque: 8Nm/70in.lbs., lightly grease the mounting bolt).

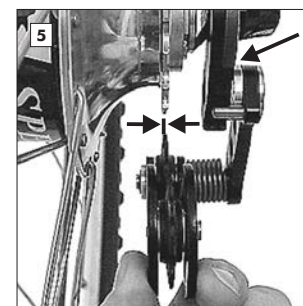

Make sure that the upper jockey wheel is correctly spaced with the distancing washers, so that it sits directly underneath the sprocket (arrowed).

ATTENTION

On dropouts thinner than 7mm, the use of the 13 tooth sprocket or splined sprockets (chainline 57mm) will require the use of the longer mounting bolt. This is available separately (Art. #8255).

POINTER

Frame Spacing /Hub O.L.D.
135/142mm Threaded Sprockets:
13 tooth = 57mm chainline (long mounting bolt)
15, 16, 17 + 21 tooth = 54mm chainline (short mounting bolt)

Frame Spacing /Hub O.L.D.
170/177mm Threaded Sprocket:
13 tooth = 75mm chainline (long mounting bolt)
15, 16, 17 + 21 tooth = 72mm chainline (short mounting bolt)

Frame Spacing /Hub O.L.D.
135/142mm with splined Sprockets:
13-21 tooth = 57mm chainline (long mounting bolt)

Frame Spacing /Hub O.L.D.
170/177mm with Splined Sprockets:
13-21 tooth = 75mm chainline (long mounting bolt)

5.2.2 Rohloff DH chain tensioner (accessory for downhill) (Art. #8245)

The *Rohloff* DH chain tensioner is specially designed for downhill use. It has a tension capacity of 10 chain links. In contrast to the regular *Rohloff* chain tensioner, it has a shorter swing arm that is restricted from moving. This feature ensures that the upper jockey wheel runs very close to the sprocket. This forced guide guarantees a positive run of the chain onto the sprocket even under extreme riding conditions. To remove the wheel, the chain tensioner mounting bolt must be loosened.

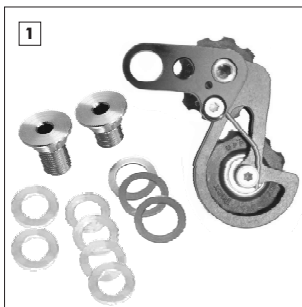

The *Rohloff* DH chain tensioner comes with 2 mounting bolts and 9 distancing washers (4 x 1mm, 2 x 3mm, 3 x 0.2mm).

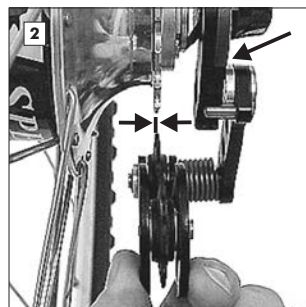

The position of the *Rohloff* DH chain tensioner must be mounted in line with the sprocket by the use of the distancing washers. Mounting procedure: See chapter 'Mounting', paragraph 5.2.1. "*Rohloff* chain tensioner".

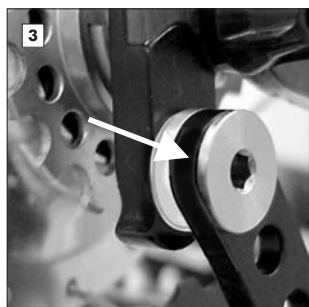

Place all three 0.2mm or one 0,5mm distancing washers between the outer side of the swing arm and the mounting bolt. This will guarantee that the swing arm is prevented from moving. Mount the *Rohloff* DH chain tensioner with the correct amount of distancing washers, so that the jockey wheels sit directly underneath the sprocket for the correct chain line.

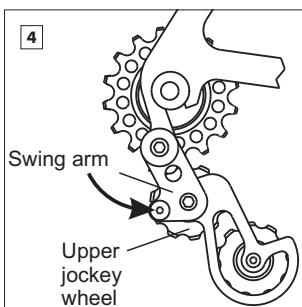

Adjust the position of the upper jockey wheel. To do this, loosen the mounting bolt and swing the chain tensioner in the arrowed direction until there is approx. 1mm space between the jockey wheel and the sprocket. Retighten the mounting bolt (5mm allen key, tightening torque 8Nm/70in.lbs.).

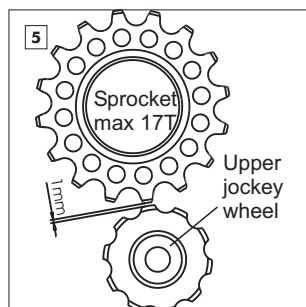

On dropouts thinner than 7mm, the use of the 13 tooth sprocket or splined sprockets (chainline 57mm) will require the use of the longer mounting bolt. This is available separately (Art. #8255).

5.3 The chain

If the frame does not have *Rohloff* OEM dropouts, horizontal dropouts or an excentric bottom bracket enabling the chain to be tensioned, then a chain tensioner must be mounted.

5.3.1 Mounting with a chain tensioner

After mounting the chain tensioner (chapter 5.2) the chain line will be correct. Now the chain has to be mounted at the correct length.

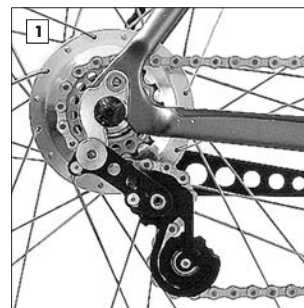

Fit the new chain over the chainring and sprocket and thread it through the chain tensioner.

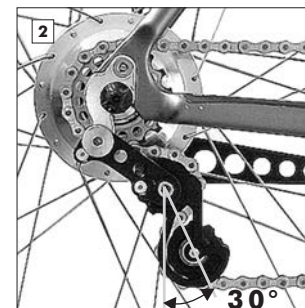

On hardtail frames the chain length should be adjusted, so that the chain tensioner cage lies between 30° and the vertical position.

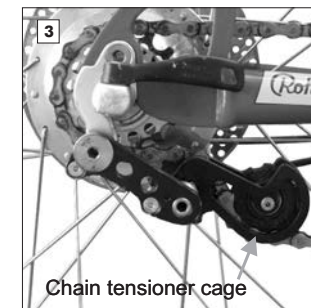

On rear suspension frames, check that the chain tensioner is not over-tensioned when the rear triangle moves the full amount of travel. The amount of chain links needed varies, depending on the position of the pivot point of the rear triangle. To check: swing the rear triangle to its end position (eg remove the rear shock spring). If the lower jockey wheel is higher than the upper jockey wheel, or if the chain tensioner cage is against the chain stay, then the chain must be lengthened.

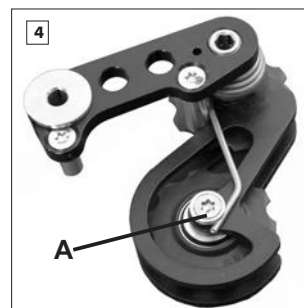

POINTER

The *Rohloff* chain tensioner can be detensioned simply by releasing the spring from the concave washer **A**. This eases the mounting of the chain.

5.3.2 Mounting without a chain tensioner

To mount a new chain, the distance between the bottom bracket and the axle must be set to the minimum.

Place the chain over the chainring and the sprocket. Remove the required amount of chain links, so that the chain is at the minimum possible length. Join the chain together following the manufacturers instructions.

Tension the chain by moving the wheel/bottom bracket until the chain no longer sags. This tension should be Regularly checked and if needed, appropriately adjusted.

5.4 Rohloff chain guide CC (Art. #8290)

The Rohloff chain guide CC prevents the chain from springing off the chainring. The Rohloff chain guide CC is adjustable for chainlines (distance between frame center and chain center) from 52mm to 62mm.

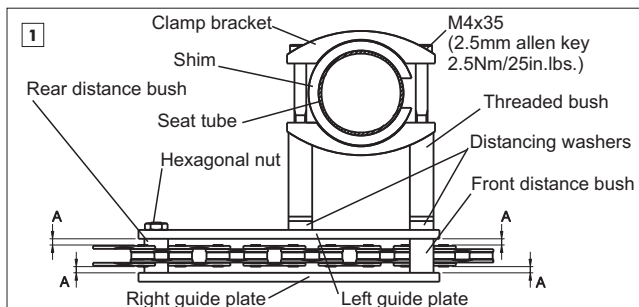

The diagram above shows the Rohloff chain guide CC mounted with all mounting parts shown. The number/type of distancing washers and shims required varies depending on the frame. Therefore, a few measurements must be taken in order to mount the Rohloff chain guide CC correctly.

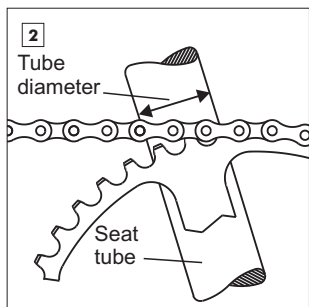

Firstly the seat tube diameter has to be measured at the point level with the top of the chainring.

3

Tube diameter	Shim
Ø28,7	Ø28,7
Ø32	Ø32
Ø35	Ø35

To mount the Rohloff chain guide CC to a seat tube with a diameter smaller than 36mm, one of the three supplied shims will have to be used. The table shows the correct shim for the different seat tube diameters.

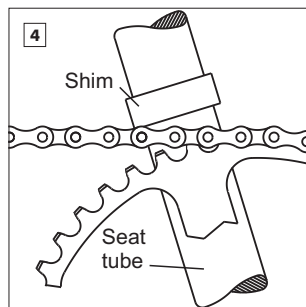

Clip the shim over the seat tube at the position level with the top of the chainring.

POINTER

For the extreme downhill use, a special downhill chain guide for the hub sprocket is recommended (Art. #8291).

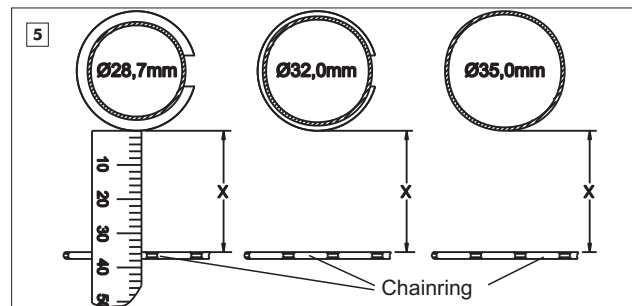

The distance X between the seat tube with shim and the inner side of the chainring determines how many distancing washers will need to be fitted. This is shown in the table.

Example: X=35mm

A 1mm distancing washer and a 2mm distancing washer are needed between the front and the rear threaded bushes and the left guide plate.

X (mm)	1mm distancing washer	2mm distancing washer
33	1	0
34	0	1
35	1	1
36	0	2
37	1	2
38	0	3
39	1	3
40	0	4
41	1	4
42	2	4

ATTENTION

The number and thickness of the distancing washers must be the same on both threaded bushes.

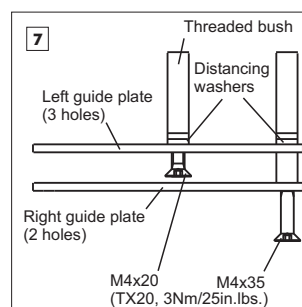

The chainguide is mounted with the appropriate number and size of distancing washers up to the point shown in the diagram above. (M4x20 and M4x35 - Torx TX20, tightening torque: 3Nm/25in.lbs.).

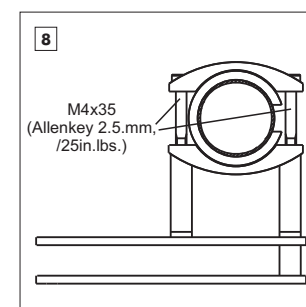

Mount the clamp brackets either side of the seat tube by screwing the bolts (M4x35 - Allenkey 2mm) through the clamp brackets into the lightly greased threaded bushes of the pre-assembled chain guide. Locate the gap of the shim between the two clamp brackets.

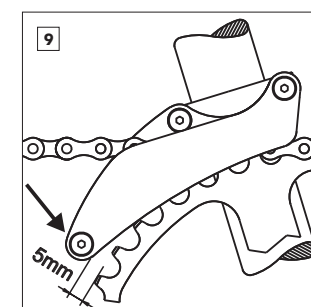

The rear distance bush (arrowed) can now be mounted using a lightly greased countersunk head bolt (M4x20 - Torx TX20, tightening torque 3Nm/25in.lbs.) and secured into the hexagonal nut below the upper chain run. Slide the chain guide down the seat tube until there is approx. 5mm between the rear distance bush and the teeth of the chainring. Make sure the chain runs parallel and central between the two guide plates (distances A, fig. 1).

6. Twist shifter (Art.No. 8200)

Fitting of the twist shifter (pre 2010). For post 2011 (Art. #8206/#8207) see Appendix.

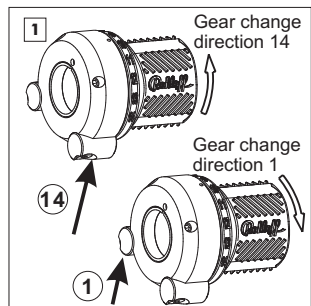

The twist shifter works with two shift cables. When the twist shifter is rotated forward (direction gear #14), then the rear shift cable 14 is pulled. When the twist shifter is rotated backward (direction gear #1), then the front shift cable 1 is pulled.

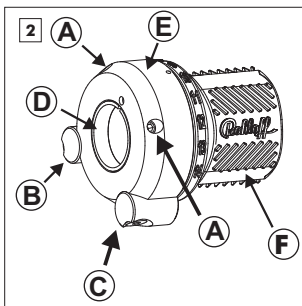

Twist shifter parts:

- A Clamp screws
- B Cable stopper 1
- C Cable stopper 14
- D Clamp ring
- E Twist shifter casing
- F Grip rubber

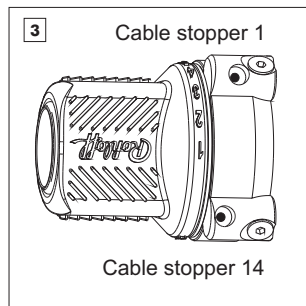

The cable stoppers 1 and 14 are fitted, so that the shift cables run parallel out of the twist shifter. The cable stopper 1 has its cable exit hole directly in the middle. The cable stopper 14 has its cable exit hole positioned to the side.



Slide the twist shifter onto the right hand side of the handlebars (diameter 22.0mm - 22.3mm) and turn the shifter casing, so that the two cable stoppers sit evenly on both sides of the brake lever.

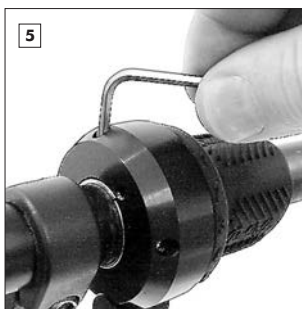

Remove the clamp screws (M5x8 - 2.5mm allen key), lightly grease them and refit them to clamp the twist shifter to the handlebars (tightening torque: 1Nm/8 in.lbs.).

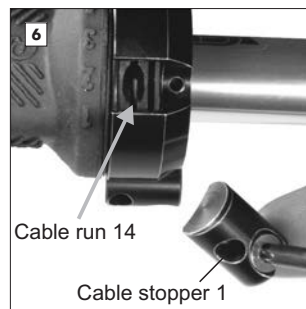

Remove cable stopper 1. Twist the grip rubber, so that the cable nipple seat of cable run 14 becomes visible (at the position of gear #2).

POINTER

It is possible to mount both of the gear cables through the same hole of one of the cable stoppers.

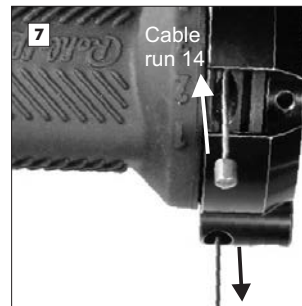

Insert the first shifter cable (shifter cable 14) into cable run 14 from below until cable appears out of cable stopper 14. Pull the cable until the nipple sits firmly in the cable nipple seat.

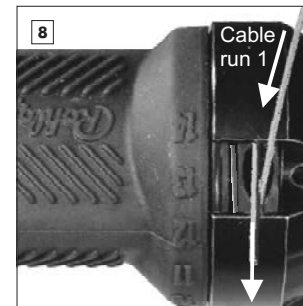

Twist the grip rubber, so that the cable nipple seat of cable run 1 becomes visible (at the position of gear #13). Insert the second shifter cable (shifter cable 1) into cable run 1 from above until the cable appears out of cable feed 1. Pull cable until the nipple sits firmly in the cable nipple seat.

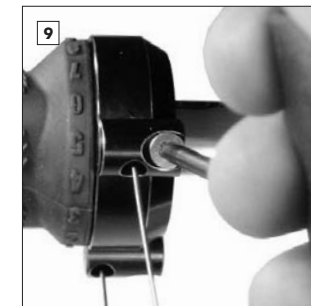

Insert shifter cable 1 into the cable stopper 1 that was removed. Refit cable stopper 1 to the twist shifter casing (M4x16 - Torx TX20, tightening torque: 3Nm/25 in.lbs.).

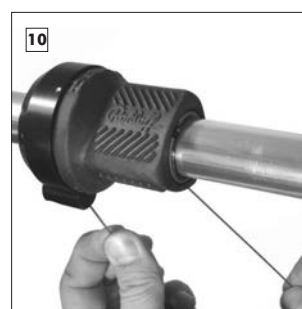

Now control that the twist shifter rotates freely by grabbing both shifter cables and pulling them in turn, so that the grip rubber rotates from just before the number 1 to just past number 14.

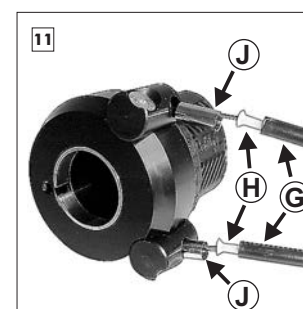

The flaired end to the liners **H** must be mounted between the cable housing **G** and the housing caps **J** at the twist shifter. This is important to prevent the liner from being pulled into the cable run itself.

ATTENTION

Mount the cables dry, without the use of grease or oil.

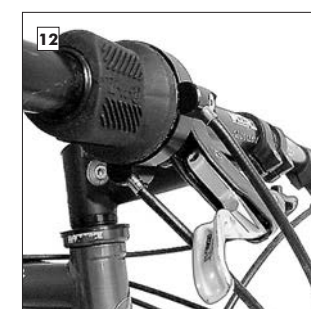

It may be necessary to adjust the angle of the twist shifter now that the cables are fitted, so that the cables don't touch the brake lever.

ATTENTION

Clamp the twist shifter only so tight that it is not possible to move the twist shifter casing by hand.

7. Cable routing

7.1 Shifter cables (Set 1.8m Art. #8268 / 2.5m Art. #8267)

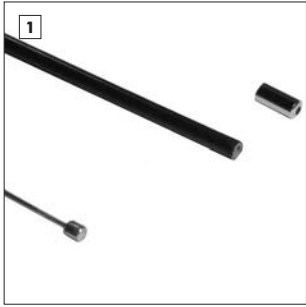

The shifter cables each comprise of a spirally wound steel outer housing (diameter 4.7mm) with integrated nylon liner, a 1.1mm stainless-steel shifter cable with cylindrical nipple (diameter 4x5mm) and four sealed cable housing ferrules.



The cable housing ferrule reduces the chances of dirt and moisture entering both the shifter cables and twist shifter.



When mounting, make sure the shifter cable housings are not pinched before mounting the ferrules. This will ensure the cables are well protected from dirt and moisture.

ATTENTION

The shifter cables are to be mounted dry (free from oil or grease). The nylon-stainless steel combination runs service free.

POINTER

The spiral housing of the shifter cables gives a positive feeling to the gear change through the twist shifter. Other shifter cable housings (e.g. SIS cables) reduce this positive feeling.



Cable Manager Kit (Art. #5201)

A special Cable Manager Kit is available consisting of 3 cable ties, 2 double sided sticky tabs and 2 guides that secure the SPEEDHUB shifter cables to the frame. One kit will hold a cable secure in two positions - a great way to secure cables to frames without brazed-on guides.



7.2 Internal gear mech

7.2.1 Cable routing via the brake boss

With the internal gear mech, the shifter cables run from the twist shifter to the cable guide. This could be located on the brake boss or by frame clamp on the chainstay. The minimum distance from the axle to the cable guide is 240mm.

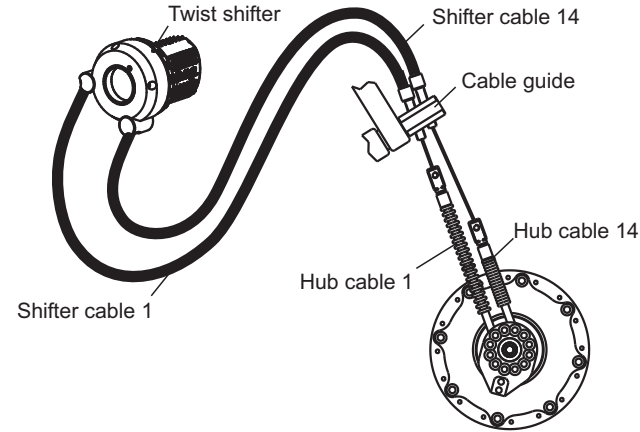

When pulling the shifter cable 1, lower gears are engaged. When pulling the shifter cable 14, higher gears are engaged. Gear cable 1 lies to the front of the twist shifter as well as to the front of the cable guide. Gear cable 14 lies to the back of the twist shifter as well as to the back of the cable guide.

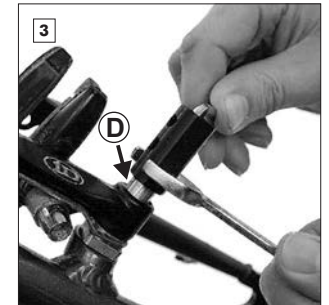
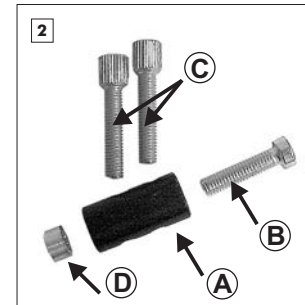
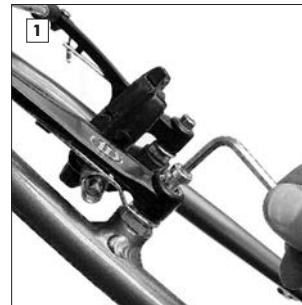

When routing the shifter cables of the internal gear mech along the top tube, the cable guide is mounted to the brake boss. Prior to routing the cables, the cable guide must be secured to the left side brake boss. The original brake boss securing bolt must be removed (this will be replaced with the new bolt supplied). All other parts of the brake remain in place.

Cable guide 13°:

- A** Cable guide
- B** Mounting bolt (M6x25)
- C** Cable adjuster (2x)
- D** Spacer

Spacer **D** must be used when:

- Mounting bolt is too long for securing to the brake boss
- Cable guide **A** interferes with the smooth running of the brake operation (eg parallel push linkage certain types of V-brake system).

Fit the mounting bolt through the cable guide (and spacer, when necessary) and screw into the brake boss with a little grease (4mm allen key, tightening torque: 6Nm/51 in.lbs.). Hold the cable guide in position with a 13mm wrench.

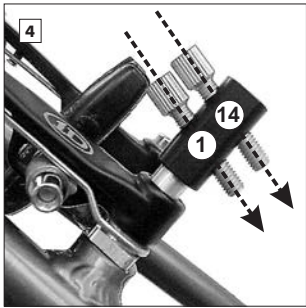

With a little grease on the bolt, screw the cable stop onto the brake boss. The cable stop should be held in position with a 13mm wrench during this process. This ensures that the cable adjusters face in the correct position once the cable stop is secure.

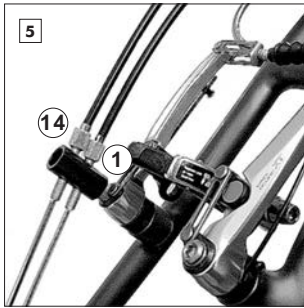

Thread shifter cable 1 from the twist shifter into the cable adjuster 1 at the cable guide. Do the same for shifter cable 14 into cable adjuster 14.

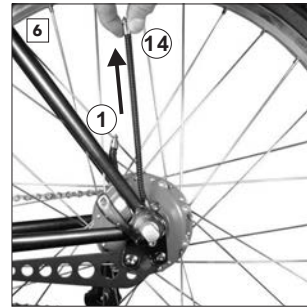

Select gear #14. Do this by holding the rear hub cable 14 by the bayonet connector and pulling this through all the gears until the end stop is reached (end position = gear #14).

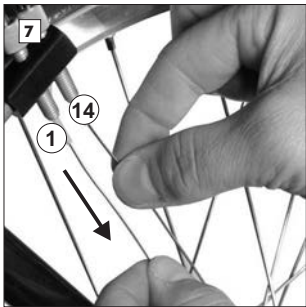

Pull both shifter cables to the end stop in turn to make sure that the cable housings sit correctly in the cable stops. When pulling shifter cable 14, the twist shifter should turn in the direction of gear indicator #1. When pulling shifter cable 1 the twist shifter should turn in the direction of gear indicator #14. Should this not be the case, switch over the cables within the cable guide.

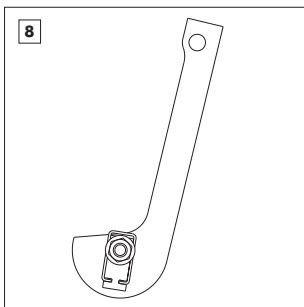

POINTER

The shifter cable measurement tool (Art. #8506) can be used for easy and precise measurement of the shifter cable length.

The following steps show how to correctly measure the shifter cable length without the help of this special tool.



Pull shifter cable 1 to the end stop. The twist shifter will turn over gear indicator #14 to its end stop and shifter cable 14 gets pulled back.

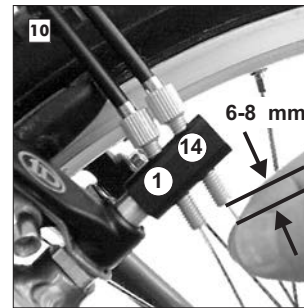

Pull shifter cable until the gear indicator #14 on the twist shifter meets up with the red dot of the twist shifter body.

POINTER

Both cable adjusters must be unscrewed approx. two turns from the cable guide.

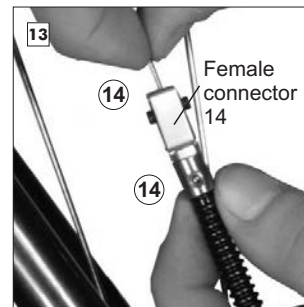

Thread the shortened shifter cable 14 fully into the hole of bayonet connector 14 (approx. 10mm deep).

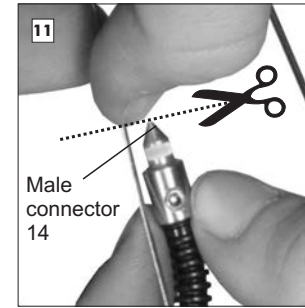

Pull hub cable 14 out by the bayonet connector until its end stop and hold it up against shifter cable 14. Cut the shifter cable at the point level with the top of the bayonet connector.

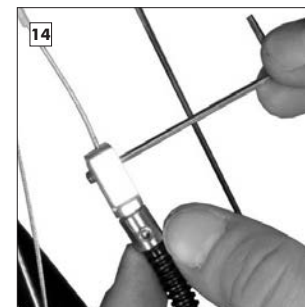

Tighten up one of the headless screws until it is flush with the outside of the female connector. Now tighten up the other headless screw. (M4x4 - 2mm allen key, tightening torque 1.5Nm/12in.lbs.).

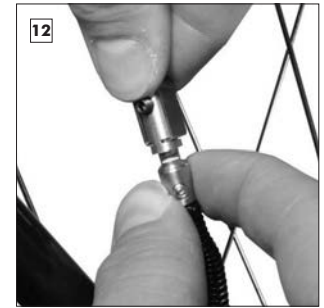

Unscrew both the headless screws of the female connector by approx. 2mm. Place the female connector over the male bayonet connector.

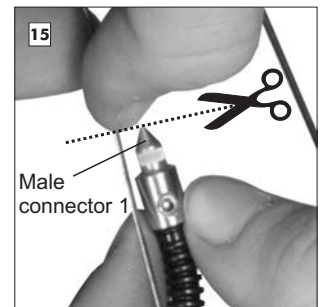

Pull hub cable 1 out by the bayonet connector until its end stop. The connected shifter cable 14 will automatically be pulled in the other direction. Pull shifter cable 1 tight, so that the cable is tensioned and hold it up against hub cable 1. Cut the shifter cable at the point level with the top of the bayonet connector.

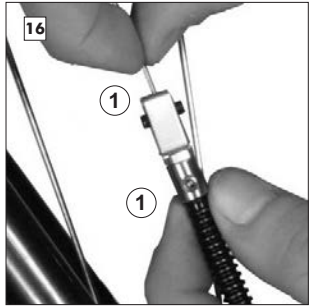

Open the male/female connectors of cables 14, so that joining shifter cable 1 with a female connector becomes easier. Place the female connector over the male bayonet connector and thread the shortened shifter cable 1 fully into the hole of the bayonet connector 1 (10mm deep), tighten up the headless screws. Rejoin the disconnected cables 14.

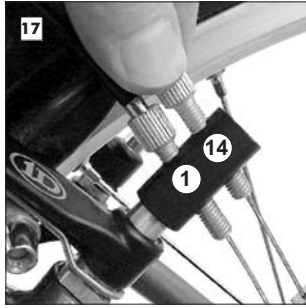

Turn the twist shifter back and forth several times to make sure that the shifter cables are sitting correctly within the cable guides. **For a lighter shifting, set the cable tension (by the use of the cable adjusters), so that the twist shifter has about 2mm play.** Winding out the cable adjusters increases the shifter tension, winding the cable adjusters in decreases the shifter tension.



Check that all 14 gears are available (14 gears = 13 clicks of the twist shifter) by rotating the twist shifter forwards to the end stop (gear #14) and backwards to the end stop (gear #1).

7.2.2 Cable routing via the chainstay

When routing the shifter cables via the chainstay, the 0° cable guide (Art. #8260) must be mounted at a minimum distance of 240mm away from the hub's axle. This should be mounted in a position, so that the hub cables run in the straightest line possible towards the shifter cables.

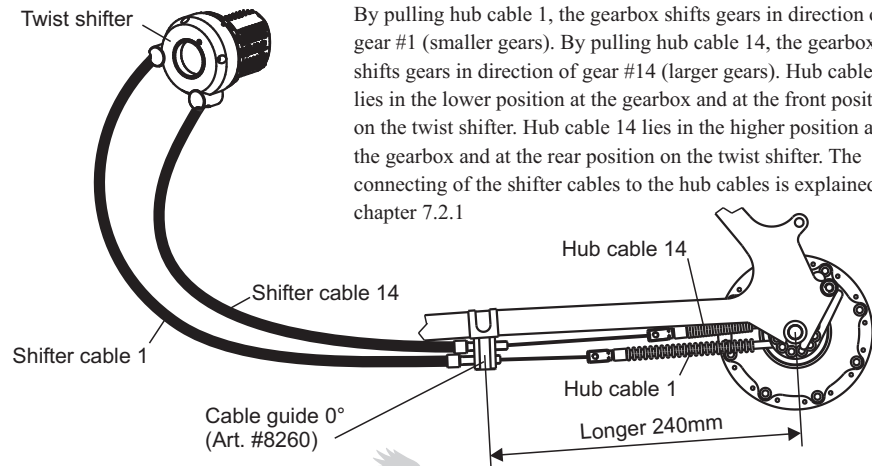

By pulling hub cable 1, the gearbox shifts gears in direction of gear #1 (smaller gears). By pulling hub cable 14, the gearbox shifts gears in direction of gear #14 (larger gears). Hub cable 1 lies in the lower position at the gearbox and at the front position on the twist shifter. Hub cable 14 lies in the higher position at the gearbox and at the rear position on the twist shifter. The connecting of the shifter cables to the hub cables is explained in chapter 7.2.1

7.3 External gear mech

With the external gear mech, the shifter cables run uninterrupted from the twist shifter to the cable box, for this reason, there is no need for a separate cable guide. The gear mechanism is controlled by the cable box which sits on the external transfer box, mounted directly on the hub.

7.3.1 Cable routing via the chainstay

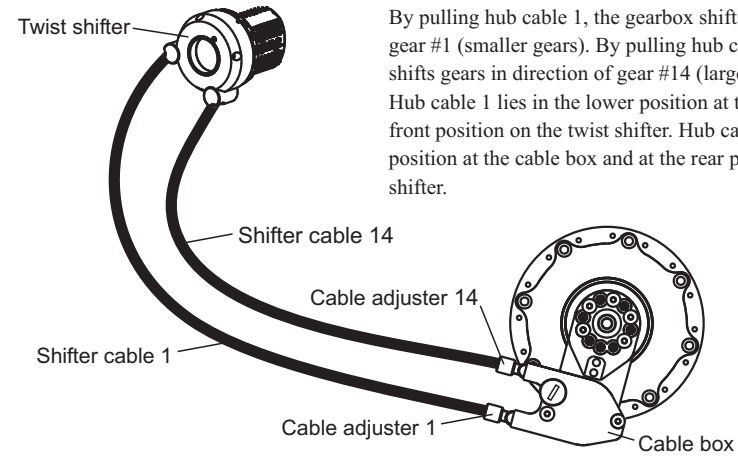

By pulling hub cable 1, the gearbox shifts gears in direction of gear #1 (smaller gears). By pulling hub cable 14, the gearbox shifts gears in direction of gear #14 (larger gears).

Hub cable 1 lies in the lower position at the cable box and at the front position on the twist shifter. Hub cable 14 lies in the higher position at the cable box and at the rear position on the twist shifter.

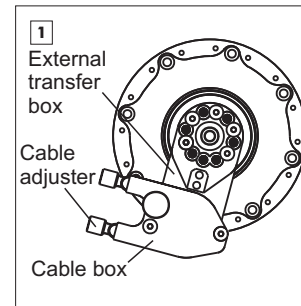

Secure the cable box to the external transfer box (which should be in the correct, pre-adjusted position) with the knurled headed screw. Insert the two cable adjusters into the cable box. The diagram shows the gear transfer box mounted in line with an OEM axle plate but the type and position of axle plate can vary from that illustrated.

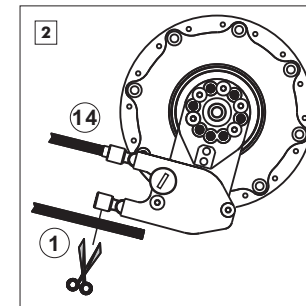

Route the shifter cables from the twist shifter in the direction of the cable box and cut the housing to the appropriate length and **mount a cable housing cap on each end.**

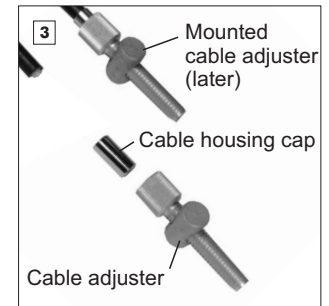

Insert the shifter cable completely into the cable housing and check that the cable housing is sitting correctly in all cable stops. Do not mount the cable adjuster yet.

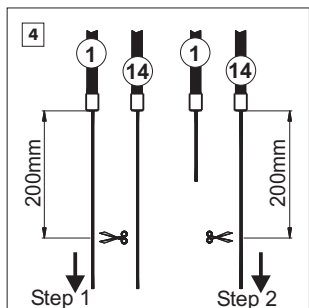

Pull shifter cable 1 completely out of the cable housing and cut the cable at a distance of 200mm from the end of the housing cap. Do the same for cable 14.

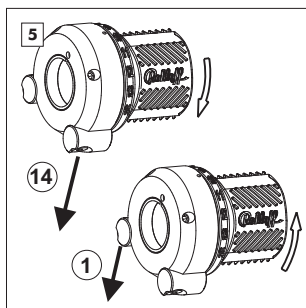

Insert the shifter cables into the cable adjusters. Pull out shifter cable 14 as far as possible, the twist shifter will rotate in the direction of end stop 1. Pull out shifter cable 1 as far as possible, the twist shifter will rotate in the direction of end stop 14. To make sure that the gear display doesn't get reversed, check that the lower shifter cable on the twist shifter is fed into the top adjuster on the cable box.

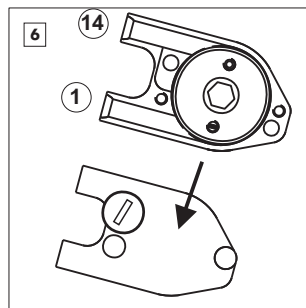

Remove the cable box from the external transfer box. Remove both torx screws (M4x10 - Torx TX20). Remove the cover of the cable box and remove the cable pulley.

POINTER

The 200mm measuring pipe (Art.No. 8712) can be used for quick and precise measurement of the shifter cables.

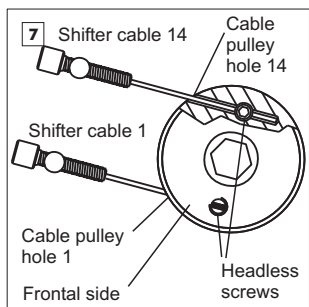

Loosen both headless screws approx. three turns (2mm allen key). Insert shifter cable 1 fully into cable pulley hole 1 and shifter cable 14 fully into cable pulley hole 14. Make sure that the front side of the cable pulley is facing upwards during this process (as in the diagram).

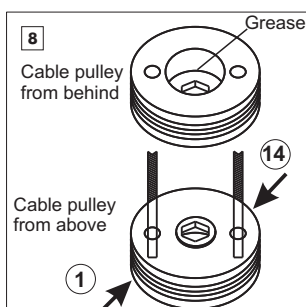

Tighten up the headless screw 1 from behind and the headless screw 14 from the front (M4x4 - 2mm allen key, tightening torque 1.5Nm/12in.lbs.).

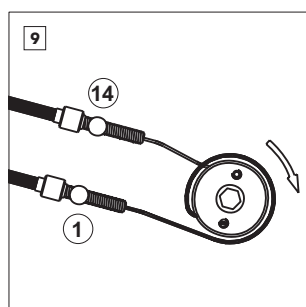

Wind shifter cable 1 clockwise around the cable pulley (making sure that the cable sits correctly within the cable runs).

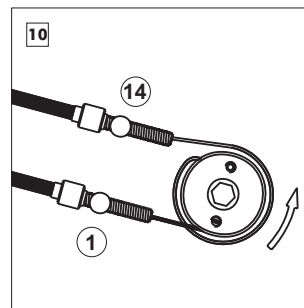

Wind shifter cable 14 anticlockwise around the cable pulley (making sure that the cable sits correctly within the cable run). **The cable pulley runs must be completely filled by the gear cables.**

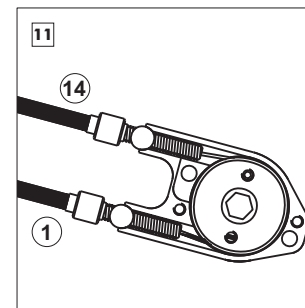

Place the cable pulley with the cable adjusters back into the cable box. Rotate the twist shifter from gear position 1 to gear position 14 and back to check that the cable pulley rotates freely.

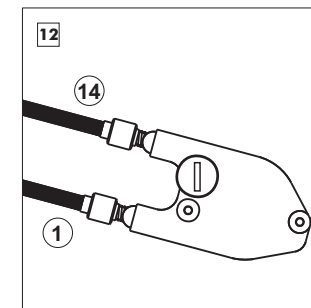

With a little grease, use both torx screws (M4x10 Torx TX20) to reattach the cable box cover to the cable box (tightening torque: 3Nm/25in.lbs.).

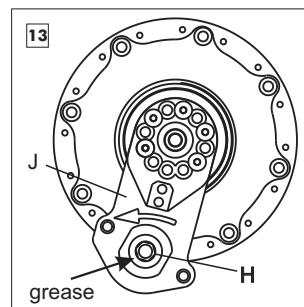

Turn the hexagonal peg **H** on the external transfer box **J** in an anticlockwise direction with the use of an 8mm wrench. This will put the gearbox into gear #14. Lightly grease the brass bearing ready for the cable pulley.

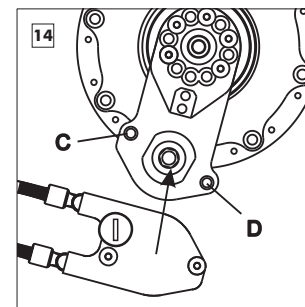

Rotate the twist shifter into gear position 14 and using the two locating pegs **C** and **D**, place the cable box over the external transfer box.

POINTER

Rotate the twist shifter around the gear position 14 to ease the connection of the cable box to the external transfer box.

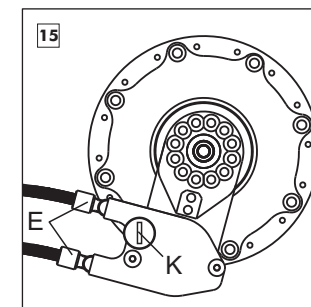

Connect the cable box securely to the gear transfer box and tighten up the knurled head screw **K**. **For a lighter shifting between gears, set the cable tension (by the use of the cable adjusters **E**), so that the twist shifter has about 2mm of play for a lighter shifting between gears.**

7.3.2 Cable routing via the top tube

The cutting of the shifter cables, nylon liner and the cable housing as with the mounting of the cable pulley are to be carried out the same as in chapter 7.2.1.

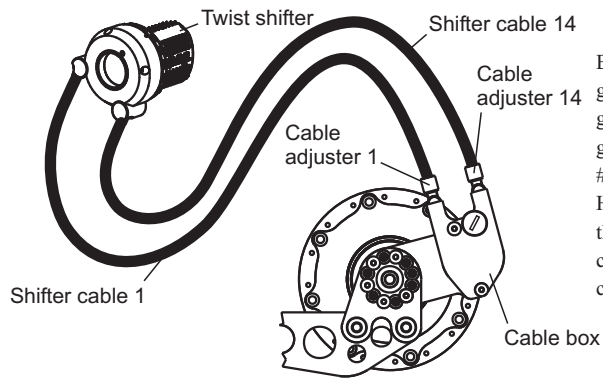

By pulling hub cable 1, the gearbox shifts gears in direction of gear #1 (smaller gears). By pulling hub cable 14, the gearbox shifts gears in direction of gear #14 (larger gears). Hub cable 1 lies in the front position at the cable box and on the twist shifter. Hub cable 14 lies in the rear position at the cable box and on the twist shifter.

7.4 Adjusting the gear display

The gear display is to be found on the body of the twist shifter. The twist shifter rubber itself has the numbers 1 - 14. The gear display can be correctly aligned with the help of the cable adjusters on the cable guide (internal gear mech) or on the cable box (external gear mech).



After the cable tension has been correctly adjusted, the gear display can be adjusted by winding one cable adjuster in and the other outwards by equal amounts.

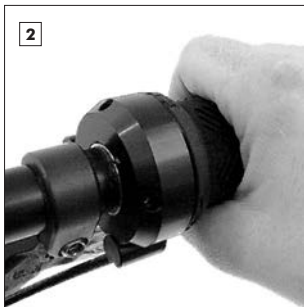

Check that all 14 gears are available (14 gears = 13 clicks of the twist shifter) by rotating the twist shifter forwards to the end stop (gear #14) and backwards to the end stop (gear #1).

ATTENTION !

If all 14 gears are not reachable after connecting the cable box to the external transfer box, then the gearbox or the twist shifter were not in gear position 14 while connecting. To correct this, see page 16, paragraph 3.2. "Maintenance and care".

8. First oilfill

Filling with oil

When the Rohloff SPEEDHUB 500/14 is delivered fitted in a complete bike, then it is already filled with oil. When not, it will need to be filled with 25ml Rohloff SPEEDHUB OIL before usage. A 25mm bottle of Rohloff SPEEDHUB OIL is included in the package.

POINTER

For a quick and clean filling of the oil or when changing the oil, we recommend the use of the Rohloff Oil Change Kit (Art. #8410).

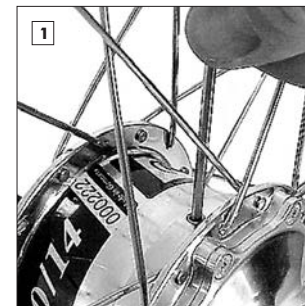

Turn the hub so that the drain screw can be seen on the top. Remove drain screw (3mm allen key).



Screw the oil filling tube into the oil drain hole and insert the nozzle of the oil bottle into the filling tube. Continually squeeze the oil bottle until the contents has been completely filled into the gearbox.

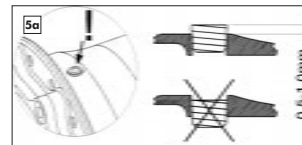

To fill the hub via syringe, fasten the oil filling tube to the syringe and secure it with a drop of superglue before use. Draw the SPEEDHUB OIL into the syringe, then screw the tube into the drain hole.



Squeeze the Rohloff SPEEDHUB OIL into the gearbox. **To equalize the air pressure within the hub, approx. 25ml of air should be drawn back into the syringe. This will prevent the oil from leaking out of the hub, when removing the filling tube.**

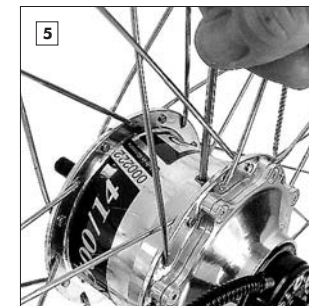

Replace the oil drain screw and tighten this up securely (3mm allen key, tightening torque: 0,5Nm/4in.lbs.).

ATTENTION !

The oil drain screw must not be inserted any further than flush with the hub shell. Any deeper could result in periodic drive loss in certain gears.

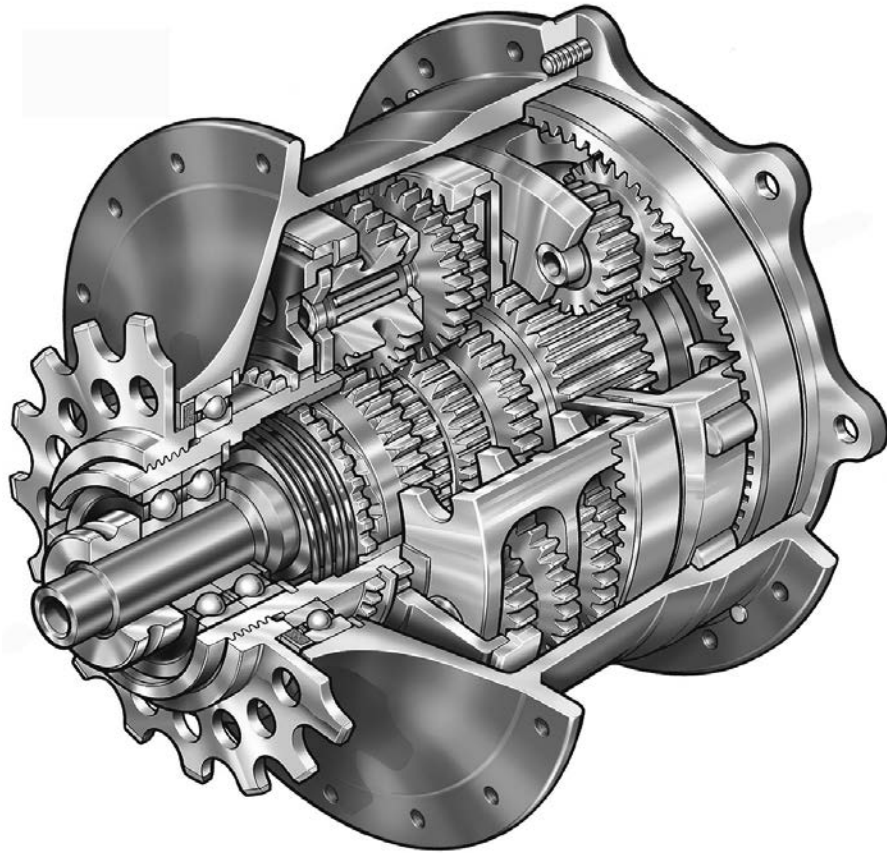

Rohloff SPEEDHUB 500/14 in cutaway view

1. Oil change	87
2. Maintenance and care	89
3. Sprocket reversing/replacing	90
4. Changing of brake discs	91
5. Changing the gear mech	
5.1 Removal of one-piece axle ring	92
5.2 Removal of quick-change axle ring	92
5.3 Mounting the external gear mech	93



1. Oil change

An oil-change must be completed every 5000km or once per Annum to ensure the 25ml quantity of oil is retained and is free from dirt/moisture contamination. This process ensures that the *SPEEDHUB 500/14* will always contain enough oil for lubrication (regardless of oil lost due to sweat oil) and also ensures that any penetrated moisture is rinsed out.

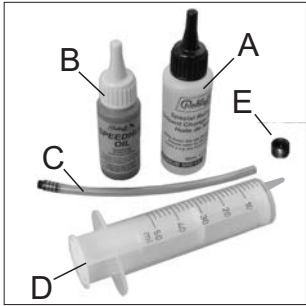

The Oil Change Kit consists of:
A 25ml cleaning oil in a 50ml bottle*
B 25ml *Rohloff SPEEDHUB OIL*
C Oil filling tube
D Non returnable syringe 50ml
E Drain screw with new seal
 The oil filling tube should be placed over the syringe and secured with a drop of super-glue before use.

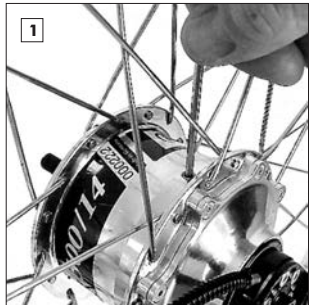

To change the oil, the *Rohloff SPEEDHUB 500/14* should be left at room temperature (because the oil flows better). Turn the hub, so that the drain screw can be seen on the top. Remove drain screw (3mm allen key).



Draw the 25ml cleaning oil into the syringe, screw the filling tube into the drain screw hole and fill the cleaning oil into the hub. **After this, use the syringe to draw out a little air out into the syringe.** Remove the filling tube and refit the drain screw.

POINTER



* There will already be approx. 25ml fluid in the hub (old oil and any penetrated moisture). After the cleaning oil is also filled into the hub then there will be approx. 50ml fluid to drain out. For this reason the cleaning oil comes in a 50ml bottle so that the old fluid can be drained out into this bottle for safe disposal.

To rinse the hub properly, ride approx. 1km or turn the wheel by hand using the cranks for approx. 3min whilst simultaneously swiching between gears #3 and #5. In these gears all planetary gear sets are in use, making sure that the cleaning fluid is well rinsed through in order to thin out the old oil for easier removal.

TIP



It is important to protect the brake disk/pads (if mounted) with a clean cloth to minimize the possibility that oil could spray out onto them.

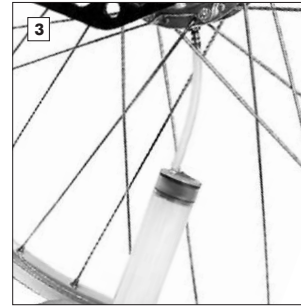

Remove the drain screw (3mm allen key) and refit the filling tube and syringe. Turn the wheel, so that the filling point is underneath the hub. Wait approx. 15mins with the wheel in this position, then use the syringe to draw out the old fluid. Remove the syringe and filling tube, use this to empty the fluid into the empty 50ml cleaning oil bottle.

ATTENTION



The *Rohloff SPEEDHUB 500/14* must be filled **exclusively with Rohloff oils (gear box/cleaning oils)**. The use of other types of lubricants and/or cleaning fluids could lead to the damage of the inner mechanism's nylon components.

Used oil should be taken to a specialized oil disposal point, so as to keep pollution levels down.

Rohloff SPEEDHUB OIL and cleaning oil can be disposed of together with other motor oils.

Do not expose to direct sunlight.

Keep out of reach of children!

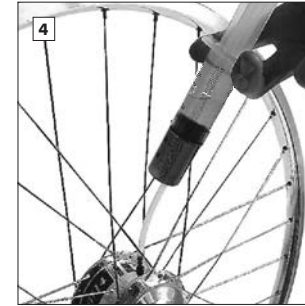

Draw 25ml *SPEEDHUB OIL* into the syringe and insert this into the hub. Draw out approx. 25ml of air to keep the pressure correct inside and therefore, avoid oil seeping back out, when removing the filling tube.

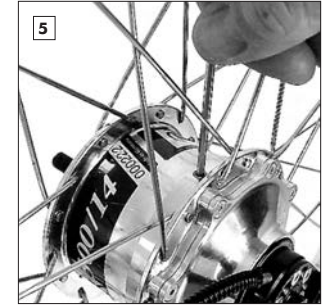

Fit a new oil drain screw and tighten correctly (Allen Key SW3, tightening torque 0.5Nm). As long as the thread sealant is not worn, then the old oil drain screw may be used repeatedly.



ATTENTION



The oil drain screw must not be inserted any further than flush with the hub shell. Any deeper could result in periodic drive loss in certain gears.

Danger



HEALTH HAZARD

Rohloff Cleaning Oil Art.No. 8402-25ml, 8407-250ml, 8405-1L.

Contains distillates (petroleum), hydrotreated light. May be fatal if swallowed and enters airways. IF SWALLOWED: Immediately call a POISON CENTER or doctor/physician. Do NOT include vomiting. Store locked up. Contains Phenol, isopropylated, phosphate (3:1). May produce an allergic reaction.

2. Maintenance and care

The shifter cable tension can be altered by the cable adjusters. When winding the cable adjusters out, the cable tension is increased. For the lightest possible gear change, the tension should be just enough, so that on the twist shifter there is approx. 1/2 gear (2mm) rotational play, when in a selected gear. The dot on the twist shifter body can be aligned to the correct gear number without altering the cable tension, by winding one cable adjuster in and the other out.

ATTENTION!
Too much cable tension raises the amount of friction within the shifter cables and in turn, raises the force needed on the twist shifter to select other gears.

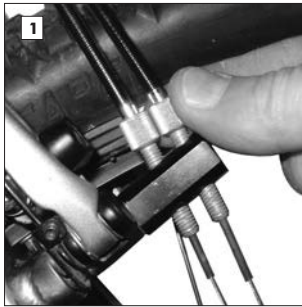

On the versions with an internal gear mech the cable adjusters can be found on the cable guide. This can be found on the left hand chain stay or attached to the left hand brake boss of the frame.

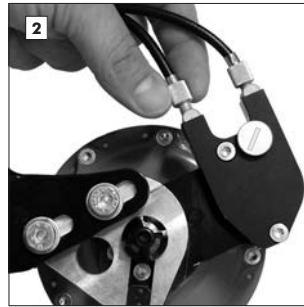

On the versions with an external gear mech the cable adjusters can be found on the cable box. This sits directly on the left hand side of the Rohloff SPEEDHUB 500/14. These cables are either routed along the seatstay or the chainstay of the frame.

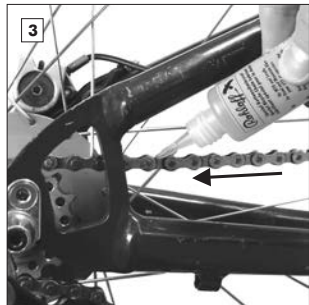

When lubricating the chain, place a thin thread of lubricant on the outside of the chain over the centre rollers. This process is carried out quicker and easier, when running the chain backwards whilst applying the lubricant.

ATTENTION!

When using a disc brake in conjunction with the Rohloff SPEEDHUB 500/14, the hub cap screws should be checked that they are correctly tightened before every ride. To reduce the chance of a flange breaking due to unequal spoke tension, we recommend that this is regularly checked by a professional bicycle mechanic.

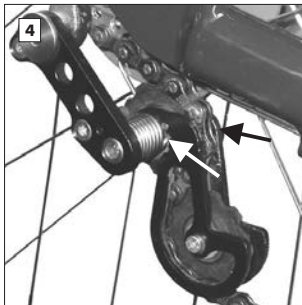

To lubricate the chain tensioner, place a drop of oil on the left and right side of the upper jockey wheel on the pivot point.



Rohloff SPEEDHUB 500/14 versions with external gear mech: To lubricate the cable pulley bearing, remove the cable box and place a little grease on the parts arrowed in the picture above.

3. Sprocket reversing/replacing - (Splined Sprocket -> Appendix)

The sprocket sizes 15, 16 and 17 of the Rohloff SPEEDHUB 500/14 are symmetrical and are therefore reversible, when worn on one side. After reversing the sprocket, fit a new chain. This will now pull on the other, unworn side of the sprocket. Once both sides are worn, the sprocket must be replaced. The 13 tooth sprocket is not reversible, and therefore, must always be replaced once worn.

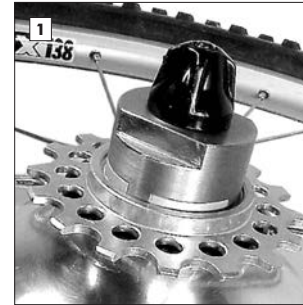

Check that the seats on the driver are clean so that the tool can be properly seated. Place the sprocket tool over the clean seats of the driver and with a quick release lever (CC) or an axle nut (TS) secure in position, so that the sprocket tool is prevented from springing out of the seats.

POINTER

Make sure that the area around the sprocket and hubshell is free from dirt, so that this cannot penetrate into the gear-unit during this process.

ATTENTION!

Make sure that the sprocket remover tool is properly secured correctly when mounting or dismounting the sprocket. The sprocket should not be removed with the use of a bench vice mounted sprocket remover tool.

Failure to comply could result in damage to the driver.

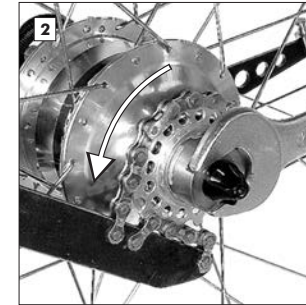

Hold the sprocket tool steady with a 24mm wrench and using a chain whip turn the sprocket anticlockwise in the opposite direction to the 24mm wrench.

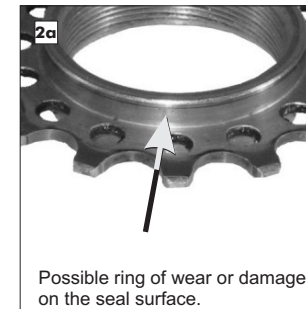

ATTENTION!

Check the sprocket for signs of damage or wear caused by the hub seal. If needed, reverse or replace it for a sprocket with undamaged seal surfaces immediately. This will in turn reduce the possibility that oil could seep out.



The sprocket can be removed over the sprocket tool. When only reversing the sprocket, clean the sprocket turn it over 180° and screw it back onto the cleaned and regreased thread of the driver in a clockwise direction. Tighten up the sprocket using the chain whip. If the sprocket needs to be replaced, simply screw the new sprocket tightly onto the driver.

POINTER

Placing the new/reversed sprocket onto the driver over the sprocket tool helps the sprocket to sit evenly on the thread, so as to eliminate the possibility of cross-threading.

A drop of special Rohloff cleaning oil (Art.No. 8402) through the holes in the new sprocket face can drastically help reduce the effect of the crank rotation while pushing the bicycle

4. Changing of brake discs

If the brake disc is worn or needs to be replaced by a different brake type, the rear wheel along with the axle plate will have to be removed before the replacement of the disc can be carried out.

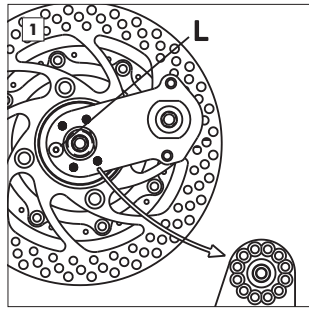

Mark the axle plate, so that it can be replaced later in the same position. Remove the axle plate screws (M4x25 - Torx TX20). Remove the axle plate and secure the external transfer box to the hub with one of these screws **L**.

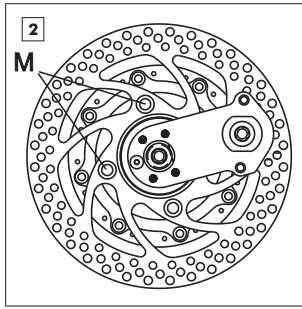

Remove the four mounting bolts **M** (M8x0.75x8.5 - 5mm allen key).

ATTENTION

The external transfer box must not be removed as the cogs within the box could fall out of synchronization. See chapter "Service" paragraph 5. "Changing the gear mech".

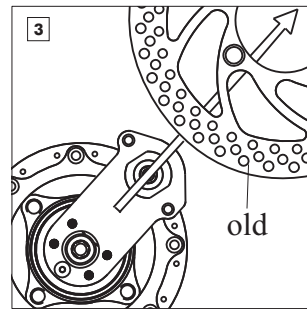

Pull the old brake disc off the center disc mount and remove this over the external transfer box.

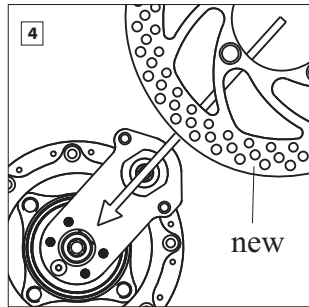

Place the new brake disc over the external transfer box and down onto the center disc mount (pay attention to the rotational direction of the brake disc).

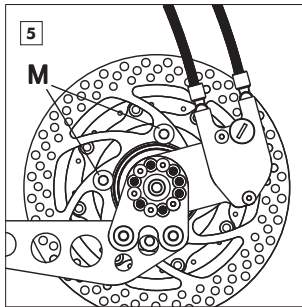

Replace the four mounting bolts **M** (M8x0.75x8.5 - 5mm allen key, tightening torque 7Nm/61in.lbs.). Remove the axle plate screw **L** from the external transfer box. Remount the axle plate in the correct position and secure this in place with the five axle plate screws (M4x25 - Torx TX20, tightening torque: 3Nm/25in.lbs.).

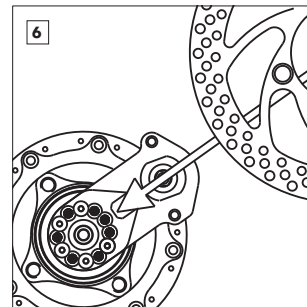

The removal of the axle plate is not necessary on the OEM versions, where the axle plate is secured to the hub in the position shown in the above diagram. The brake disc can simply be removed over the external transfer box and the axle plate together.

5. Changing the gear mech

The replacement of the gear mech is normally only needed, when mounting the hub on a different bicycle frame. It is not routine work and we advise that this work is carried out by a professional bicycle workshop.

5.1 Removal of one-piece axle ring

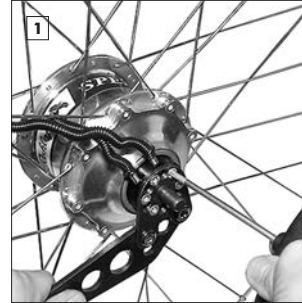

Regardless of which axle plate is mounted, the axle plate must be removed by unscrewing all six of the axle plate screws (M4x25 - Torx TX20).

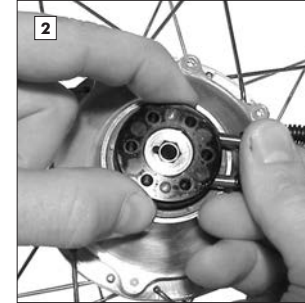

Lie the wheel on a flat surface with the axle ring facing up and the cable guides facing to the right. Rock the axle ring from side to side whilst pulling it upwards in order to loosen it from the hub.

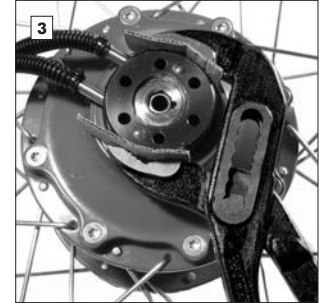

TIP

Should the axle ring not loosen by hand, use a pipe wrench to hold the axle ring tight (place cardboard between the axle ring and the pipe wrench). Rock the axle ring from side to side with the pipe wrench, whilst pulling it upwards in order to loosen it from the hub.

5.2 Removal of quick-change axle ring

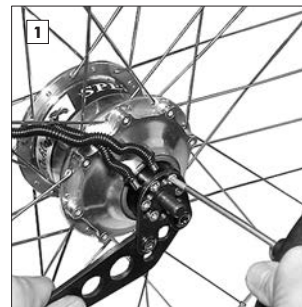

Regardless of which axle plate is mounted, the axle plate must be removed by unscrewing all five of the axle plate screws (M4x25 - Torx TX20).

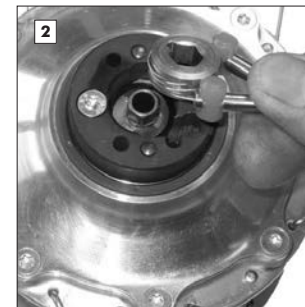

Lie the wheel on a flat surface with the axle ring facing up and the cable guides facing to the right. Pull the cable guides with the nylon cylinders and the cable pulley upwards and out of the axle ring.

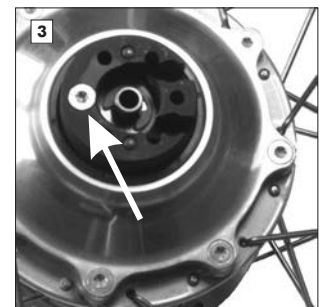

Remove the axle ring screw (M4x20 - Torx TX20) and rock the axle ring from side to side, whilst pulling it upwards in order to loosen it from the hub.

5.3 Mounting the external gear mech

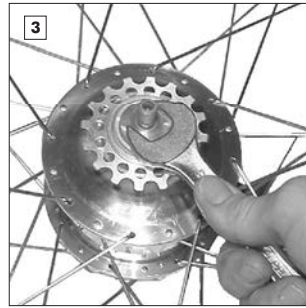
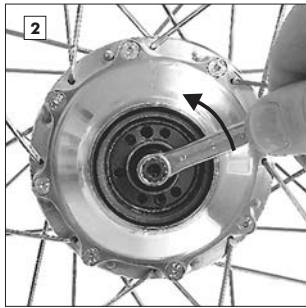
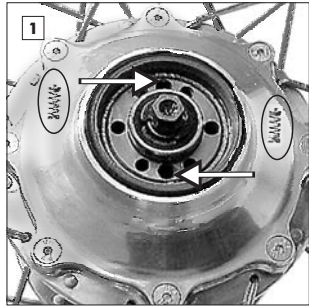

ATTENTION

The wheel must not be laid on the axle ring side once the axle ring has been removed because:

- a. Oil could leak out of the holes.
- b. The two freewheel springs could fall out of the locating peg holes.

Shift the gearbox into gear #14 by turning the hexagonal peg with an 8mm wrench carefully in an anti-clockwise direction to the end stop.

Hold the aluminium nut on the sprocket side with a 17mm wrench to prevent the axle from moving, whilst selecting the gear.



Place a new paper gasket over the locating pegs of the external transfer box, so that all holes meet up with corresponding screw holes of the axle ring. The smaller seal sits in the recess on the rear side of the axle ring.

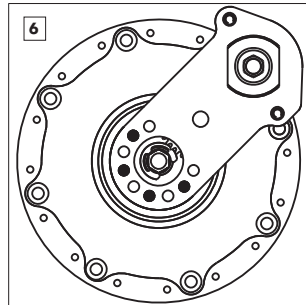

Mount the external transfer box onto the gearbox.

POINTER

The grub screw under the External Gear Mech should be fitted in the correct position. "Appendix - Grub screw of the External Gear Mech".

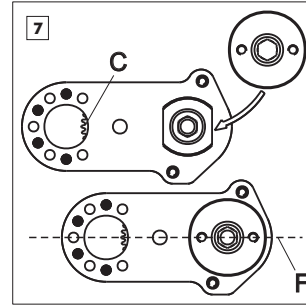

Place the cable pulley over the hexagonal peg of the external transfer box and then rotate it until the two screw holes sit on the center line F, as shown in the diagram above. Hold the cable pulley in this position.

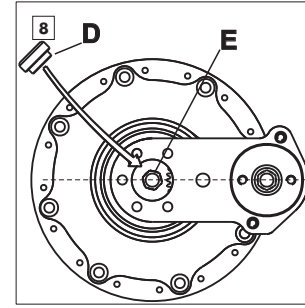

Insert cog D over the hexagonal peg E with the tothing facing outward. There is one mounting position out of the possible six, where the teeth of the cog D and the sprocket C line up. In this position the screw holes of the cable pulley remain as close as possible along the center line F. This position is the correct position. It may be necessary to turn the cable pulley lightly to the left or right to allow for an easier assembly.

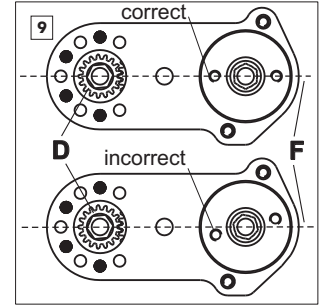

The five other mounting positions result in the screw holes of the cable pulley being substantially more out of line with the center line F. In this case, remove the cog D and try the next mounting position.

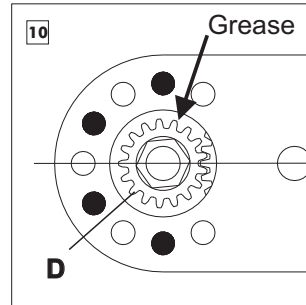

Place a small amount of grease between the cog D and the external transfer box. Remount the axle plate and secure it in the correct position with the five axle plate screws (M4x25 - Torx TX20, tightening torque 3Nm/25" lbs.).

Further steps for mounting the external gear mech can be found in chapter "Mounting", paragraph 7.3 "External gear mech".

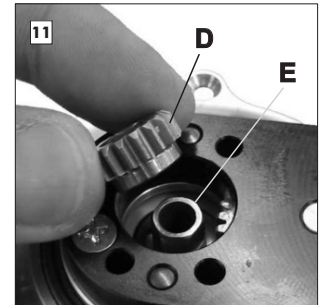

ATTENTION

The smaller side of cog D must always be mounted into the external transfer box facing inwards. When cog D is wrongly mounted, the axle plate will cause functional difficulties within the external transfer box.



A selection of splined sprockets 13-19 + 21T and Gates belt sprocket

1. Changing the hub cable (0.9mm Rohloff special gear cable).....	97
1.1 One-piece axle ring	98
1.2 Quick-change axle ring	104
2. Changing the chain tensioner spring	108
3. Changing the grip rubber	109
4. Exchanging the gear unit	
4.1 Gear unit removal	110
4.2 Gear unit installation	111
5. Hub Seal replacement	
6. Appendix	
Failure Diagnosis	119
Trouble Shooting	120
Tools and Bolts	124
Wheel lacing with a European spoke-hole pattern	125
Wheel lacing with a French spoke-hole pattern	126
Technical Data	127
Reference to Serial Number	128
Threaded Pin under External Gear Mech	129
The correct spoke choice	130-131
Possible causes for flange breakages on bicycle hubs	132-133
Flange support rings	134
Twistshifter 'light' RH - Art. #8206 - Mounting instructions	135-138
Twistshifter 'light' LH - Art. #8207 - Mounting instructions	139-142
Splined sprocket / Splined Carrier.....	143-144
Monkey Bone (IS-PM Adapter) for OEM2 axleplate	145-146
PM Bone Art. #8555 / PM axleplate (PM-PM Adapter).....	147-148
Notes	149-151
Information over the newest version Owners Manual	152
Index	153-154

1. Changing the hub cable (0.9mm Rohloff special gear cable)

The method of replacement for a worn or broken hub cable can be carried out differently depending on which axle ring type is mounted.

1. Axle ring with pressed-in cable guides (one-piece axle ring with spare parts 'Hub cables' Art. #8271)
2. Axle ring with cable guides seated within nylon cylinders (quick-change axle ring with spare parts 'Hub cable Easy Set' Art. #8573)

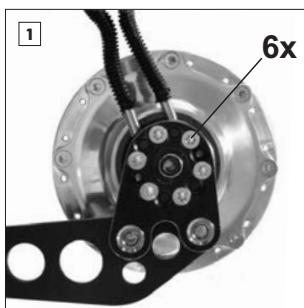

The one-piece axle ring was mounted on all internal gear mech versions until the beginning of 2003. This type of axle ring is secured to the gearbox with six axle plate screws. The cable guides of the one-piece axle ring remain fixed to the axle ring. This can be seen once the axle plate has been removed. To replace the hub cable, the axle ring complete with the cable pulley must be removed.

Replacement procedure see paragraph 1.1.

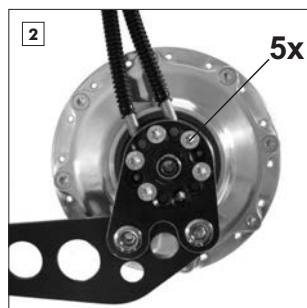

The quick-change axle ring is secured to the gear box with five axle plate screws. The axle ring remains secured to the gearbox with one more screw and the cable guides seated within black nylon cylinders rest in the axle ring. This can be seen once the axle plate has been removed. When replacing the hub cable, the axle ring remains attached to the gearbox.

Replacement procedure see paragraph 1.2.

POINTER

When correctly mounted, the hub cable should last a good 10,000km. Should the cable get damaged and need to be replaced sooner, the reason for this damage should be identified and corrected before mounting a new hub cable. Possible reasons:

1. False alignment of the axle plate or the cable guide can result in the cable rubbing against the metal of the cable adjusters/guides. (see chapter "Mounting", paragraph 4.1.2).
2. Torque not properly secured. The hub axle rotated and stretched the cables to breaking point.
3. Other physical damage (eg. crashes, accidents).

1.1 One-piece axle ring

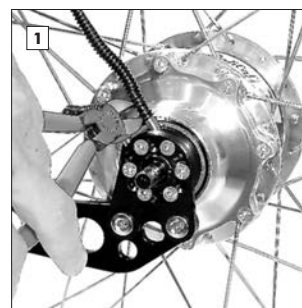

Remove the rear wheel. With good wire cutters, cut off the four cable ties that hold the concertina tubes over the hub cables.

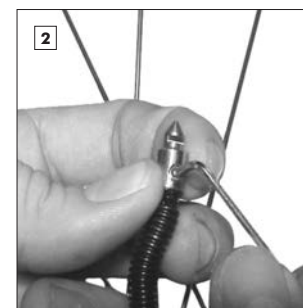

Unscrew both bayonet male connectors from the hub cables (M4x4 - 2mm allen key) and remove the concertina tubes.



To change the hub cables, the axle plate must be first removed. To do this unscrew the six axle plate screws (M4x25 - Torx TX20).

ATTENTION

Take note of the position of the axle plate against the hub cable guides for correct refitment later.



To hold the axle steady, grip the long torque arm tightly or hold the OEM or OEM2 axle plate with a 10mm wrench (see chapter "Mounting", paragraph 4.3).

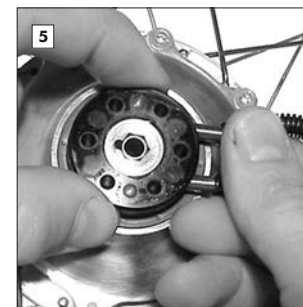

Lie the wheel on a flat surface with the axle ring facing up and the cable guides facing to the right. Rock the axle ring from side to side whilst pulling it upwards in order to loosen it from the hub.

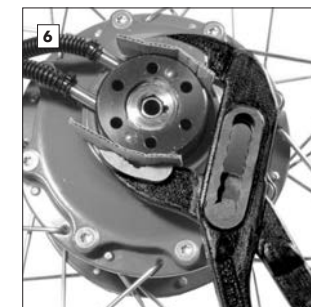

TIP

Should the axle ring not loosen by hand, use a pipe wrench to hold the axle ring tight (place cardboard between the axle ring and the pipe wrench). Rock the axle ring from side to side with the pipe wrench whilst pulling it upwards in order to loosen it from the hub.

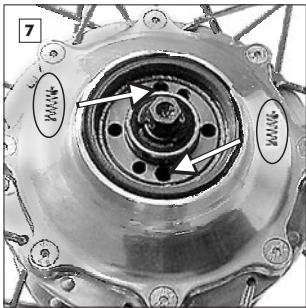

ATTENTION !

The wheel must not be laid on the axle ring side once the axle ring has been removed because:

- a. Oil could leak out of the holes.
- b. The two freewheel springs could fall out of the locating peg holes.

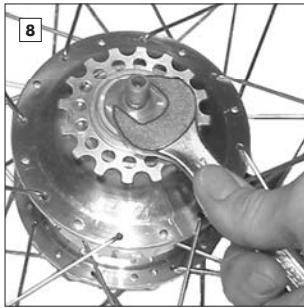

The mounting of the cable pulley must be carried out in gear #14. To do this, the axle has to be held steady with a 17mm wrench on the aluminum nut (sprocket side).

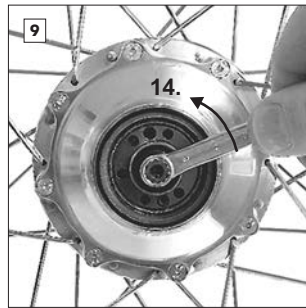

With an 8mm wrench turn the hexagonal peg in an anticlockwise direction until the end stop. Now the hub is in gear #14.



Remove both paper gaskets from the rear side of the axle ring (where applicable). Always use new paper gaskets when remounting the axle ring.

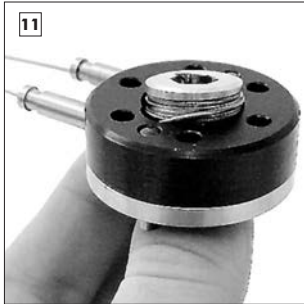

Push the cable pulley out of the axle ring from the rear side. Take care not to tilt the cable pulley for an easier removal. Remove the old hub cable and clean both the cable pulley and the axle ring.

Check cable pulley for burrs and deburr if necessary.

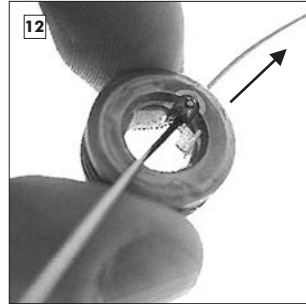

Push the new hub cable approx. half way into the cable pulleys lower hole from the inner side.

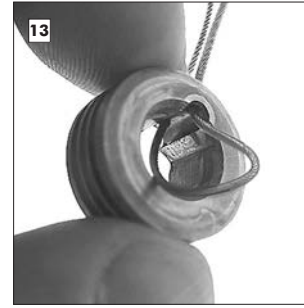

Next push the other end of the cable into the top hole of the cable pulley until both ends of the cable stick approx. the same length out of the other side.

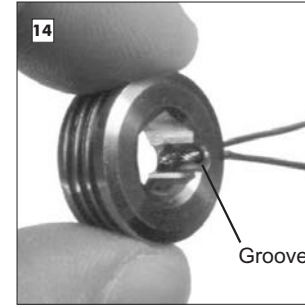

Hold the cable pulley tight and with the other hand grasp the hub cables and pull them quickly until the cable sits properly in the cable pulley without getting kinked.

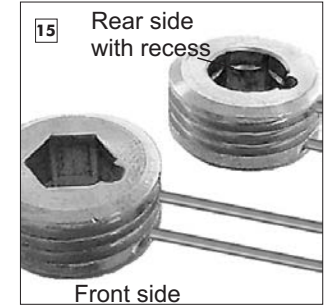

Pay attention to which side of the cable pulley is the mounting side. The back/mounting side has a recess before its hexagonal hole. The front side is without this recess.

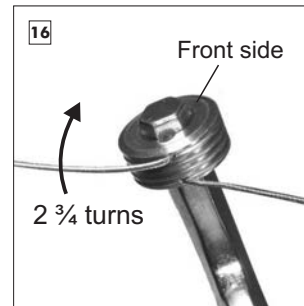

Put the cable pulley onto an 8mm allen key with the front side on top. Bend the hub cables in the direction of the cable runs in the cable pulley. The top cable should be wound approx. 2 3/4 times around the cable pulley.

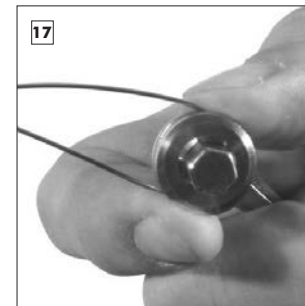

Hold both ends of the hub cable in position with thumb and index finger.

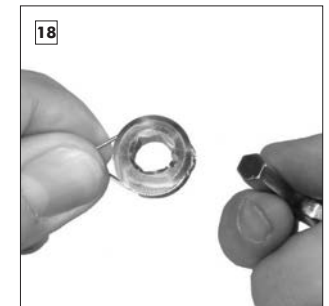

Press both ends of the hub cable together with the thumb and index finger of the other hand. Remove the cable pulley from the 8mm allen key.

POINTER

The inward groove of the cable pulley should be sitting facing in the opposite direction to the gear cable. The runs of the cable pulley must be completely filled by the gear cable.

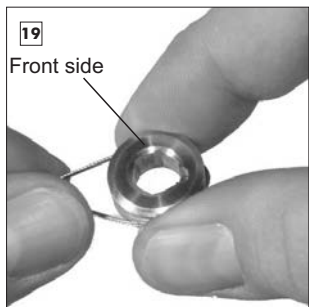

19 Grip the cable pulley with a free hand so that both ends of the hub cable are held in position. Hold this so that front side of the cable pulley faces up.

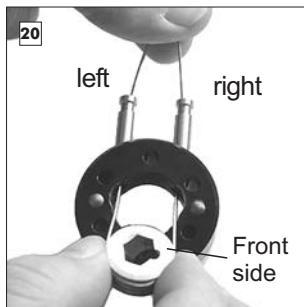

20 Thread the right end of the hub cable (long end) through the right hand cable guide. Thread the left end of the hub cable (short end) through the left hand cable guide. This procedure works a lot easier when the axle ring is held by a third hand.



21 Pull the cable pulley up to the axle ring by pulling both ends of the hub cable equally. Push the cable pulley into a parallel position with the axle ring using the thumb (from outside) and index finger (from inside) whilst keeping the tension applied to both hub cable ends. The cable pulley then springs into the axle ring hole.

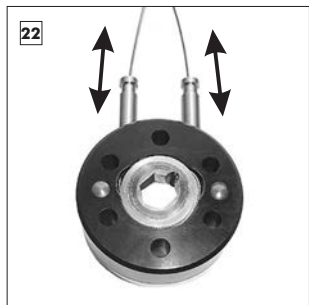

22 The cable pulley must rotate freely within the axle ring when pulling each end of the hub cable. Prevent the cable pulley from springing out of the axle ring with the thumb and index finger.

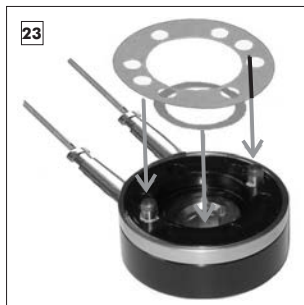

23 Place a new paper gasket over the locating pegs of the axle ring so that all holes meet up with the corresponding screw holes of the axle ring. The smaller gasket sits in the recess on the rear side of the axle ring.

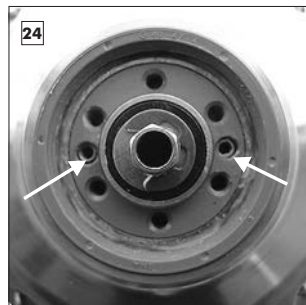

24 Lay the wheel on a flat surface so that the two locating peg holes (not threaded) lay at positions 3 and 9 o'clock (arrowed).

ATTENTION

Make sure the two freewheel springs remain in the locating peg holes.

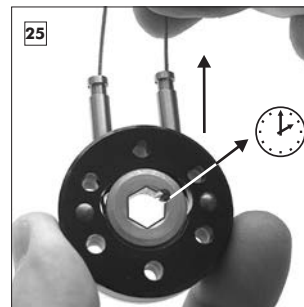

25 Hold the axle ring in the left hand and pull the right end of the hub cable until the end stop (groove rotates to about 2 o'clock).

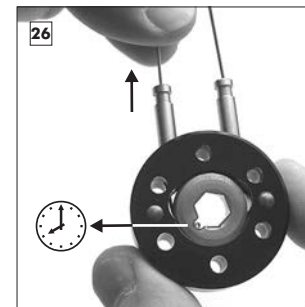

26 Pull the left end of the hub cable so that the groove rotates approx. 1/2 revolution. The groove in the cable pulley should now sit between the 7 and 8 o'clock positions. This is the position of gear #14. Hold the axle ring and the cable pulley securely in this position and place this onto the gearbox with the locating pegs in the correct holes.

POINTER

Should one end of the hub cable be pulled completely round to the end stop, the bend in the hub cable (between the cable hole of the cable pulley and the cable run) will straighten out. This bending and straightening of the hub cable will considerably shorten the cable life. Therefore, the cable pulley must always have an end position approx. half a turn away from the cable guides. This way the hub cable is guaranteed to run smoothly as it always sits in the cable run and the bend remains in place.

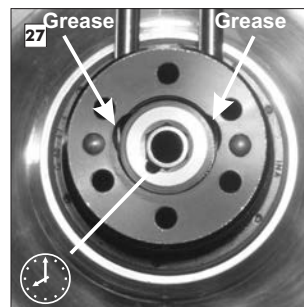

27 Make sure that the hexagonal peg sits correctly within the hole of the cable pulley (groove between the 7 and 8 o'clock positions). It may be necessary to alter the position of the cable pulley by a minimal amount. Place some grease between the cable pulley and the axle ring (arrowed). Replace the axle plate and secure into position with the six axle plate screws, tightening them in cross formation (Torx TX20, tightening torque: 3Nm/25"lbs.).

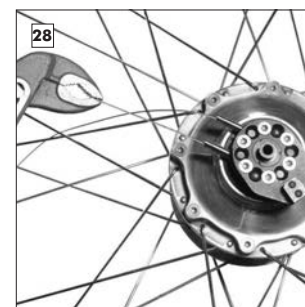

28 Check the function of the axle ring by gripping one end of the hub cable with pliers and pulling this out to the end stop. Repeat this process with the other end of the hub cable. At the end stops, both ends of the hub cables should protrude from the cables guides by the same amount.

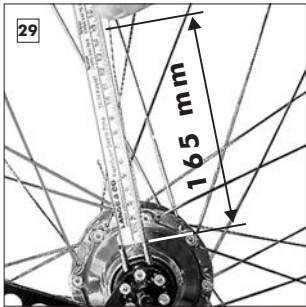

Check the rear (14) side cable is pulled out to its end stop. Measure* this rear (14) cable and cut it at 165mm with sharp wire cutters. Place a new concertina tube carefully over the cable and place the male bayonet connector on to the end of the cable.

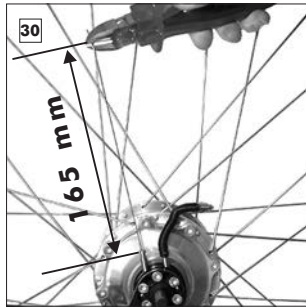

Push the cable up into the male bayonet connector as far as it will go and tighten both 4mm headless screws (2mm allen key, tightening torque: 1.5Nm/12"lbs.). Pull the front (1) side cable with pliers through the 13 clicks of the gearbox until the endstop (gear #1). Measure* this front (1) cable and cut it at 165mm with sharp wire cutters.



Place a new concertina tube and male bayonet connector over the cable. Tighten up the connector as with the other. Pull the shorter cable until both of the hub cables are approx. the same length. Place the two new concertina tubes over the cable guides and secure with cable ties. Make sure that the cable ties clamp the concertina tubes over the recess in each of the cable guides.

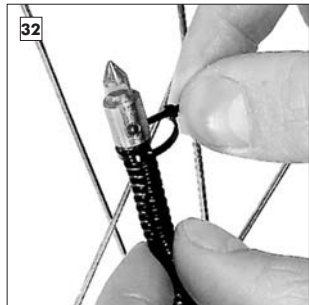

The top ends of the concertina tubes must be placed over the ends of the male bayonet connectors and secured with cable ties. Make sure that the cable ties clamp the concertina tubes over the recesses.

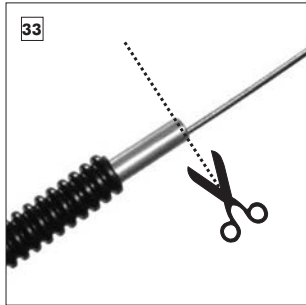

TIP



* For easier measurement of the correct cable length the special measuring pipe (Art. #8711) can be ordered. Simply place the measuring pipe as far down as possible over the cable. Cut the cable at the end of this pipe, then slide the new concertina tube over the pipe. Remove the measuring pipe, secure the male connector and the concertina tube in the correct positions.

1.2 Quick-change axle ring (after Serial Number 25300)

A Hub Cable Easy Set (Art. #8573) is available for a quick replacement. A Hub Cable including all needed parts can simply be slotted into the axle ring as a complete unit (See included instruction sheet for mounting instructions).

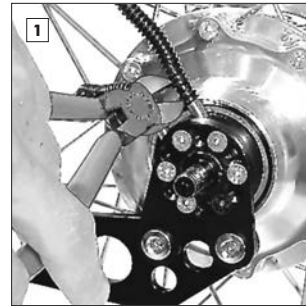

Remove the rear wheel. With good wire cutters cut off the four cable ties that hold the concertina tubes over the hub cables.

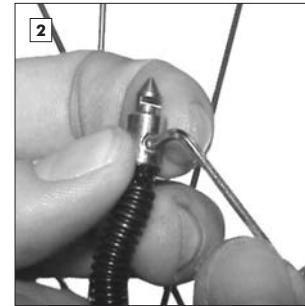

Unscrew the bayonet male connectors from the hub cables (M4x4 - 2mm allen key) and then remove the concertina tubes.

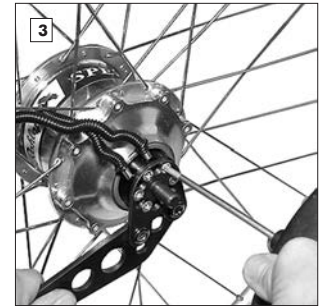

To change the hub cables the axle plate must be firstly removed. To do this, unscrew the five axle plate screws (M4x25 - Torx TX20).

ATTENTION



Take note of the position of the axle plate against the hub cable guides for correct refitment later.

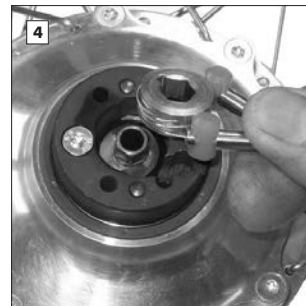

The axle ring remains attached to the axle by one more countersunk head bolt underneath the axle plate. Lie the wheel on a worktop with the axle ring facing upwards. Remove the two cable guides with the nylon cylinders and the cable pulley by rocking the cable guides from side to side until they are released from their seats within the axle ring.

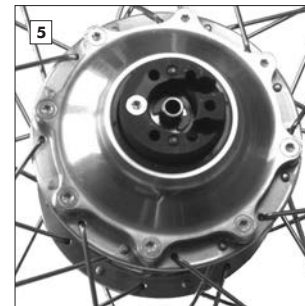

ATTENTION



Do not lie the wheel on the axle ring side, as it is possible that oil could leak out of the bolt holes.



The mounting of the cable pulley must be carried out in gear #14. To do this, the axle has to be held steady with a 17mm wrench on the locking nut on the sprocket side.



With an 8mm wrench turn the hexagonal peg in an anticlockwise direction until the end stop. Now the hub is in gear #14.

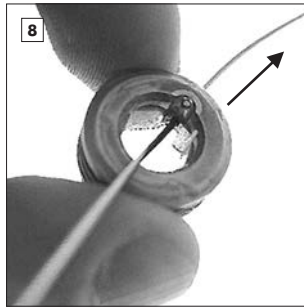

Remove the old hub cable from the cable pulley. **Clean and deburr cable pulley if necessary.** Insert the new hub cable (0.9mm) approx. half way into the cable pulleys lower hole from the inner side.



Next push the other end of the cable into the top hole of the cable pulley until both ends of the cable stick approx. the same length out of the other side.

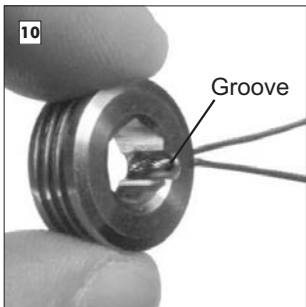

Hold the cable pulley tightly and with the other hand grasp the 0.9mm hub cables and pull them quickly until the cable sits properly in the cable pulley without getting kinked.

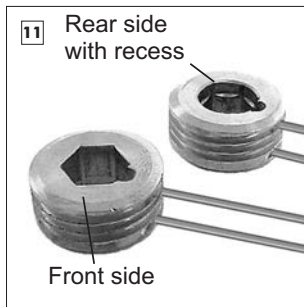

Pay attention to which side of the cable pulley is the mounting side. The back/mounting side has a recess before its hexagonal hole. The front side is without this recess.

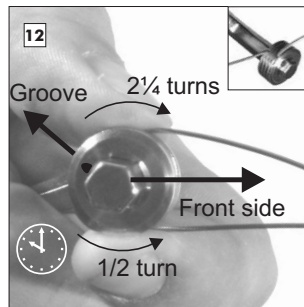

Bend the hub cables in the direction of the cable runs in the cable pulley (this is easily achieved by placing the cable pulley onto an 8mm allen key). The top cable should be wound approx. 2 1/4 times around the pulley. The bottom cable approx. 1/2 of a turn in the opposite direction.

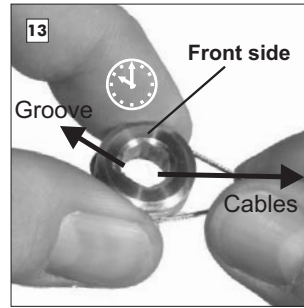

The picture shows the cable pulley with the correctly wound hub cables. The cable runs are completely filled with the gear cable and the groove faces toward the 10 o'clock position.

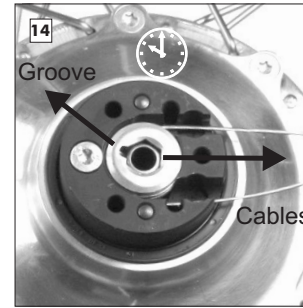

The cable pulley should be placed over the hexagonal peg of the shifting shaft with the groove facing towards the countersunk axle bolt (or as near to it as possible approx. 9-10 o'clock position). Both ends of the hub cable should be placed through the seats of the cable guides.

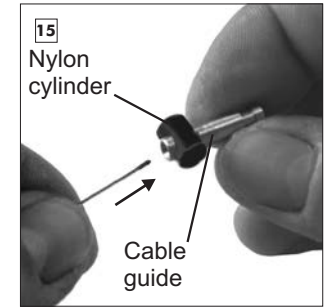

Place the cable guides over the hub cables, nylon cylinder end first!

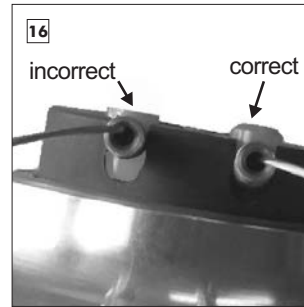

The cable guides are sitting properly in their seats of the axle ring when the rounded top of the nylon cylinder is facing upwards (as shown in the above picture).

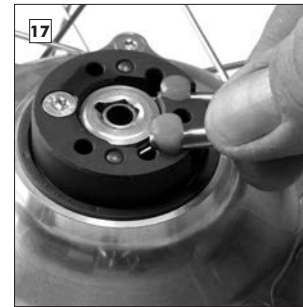

Press the nylon cylinders firmly into their seats of the axle ring.

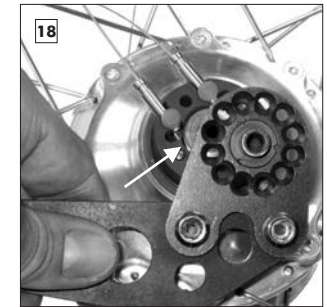

Place a little grease between the axle ring and the cable pulley. Remount the axle plate checking that it is at the same angle against the cables guides as it was before. Tighten up the five countersunk bolts (Torx TX20 - tightening torque: 3Nm/25"lbs.).

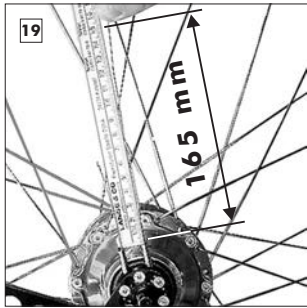

Check the rear (14) side cable is pulled out to its end stop. Measure* this rear (14) cable and cut it at 165mm with sharp wire cutters. Place a new concertina tube carefully over the cable and place the male bayonet connector onto the end of the cable.

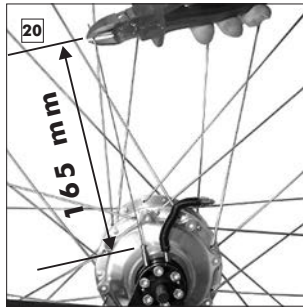

Push the cable up into the male bayonet connector as far as it will go and tighten the two 4mm headless screws with a 2mm allen key (tightening torque 1.5Nm/12"lbs.). Pull the front (1) side cable with pliers through the 13 clicks of the gearbox until the end stop (gear #1). Measure* this cable and cut it at 165mm with sharp wire cutters.

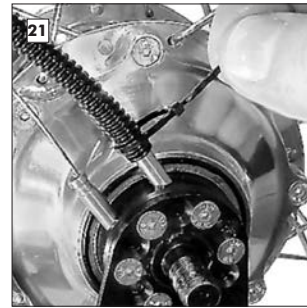

Place a new concertina tube and male bayonet connector over the cable. Tighten up the connector as with the other. Pull the shorter cable until both of the hub cables are approx. the same length. Place the two new concertina tubes over the cable guides and secure them with cable ties. Make sure that the cable ties clamp the concertina tubes over the recess in each of the cable guides.

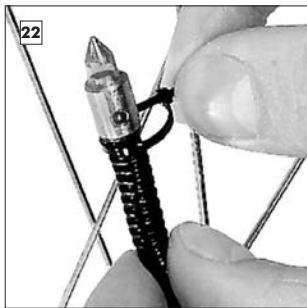

The top ends of the concertina tubes must be placed over the ends of the male bayonet connectors and secured with cable ties. Make sure that the cable ties clamp the concertina tubes over the recesses.

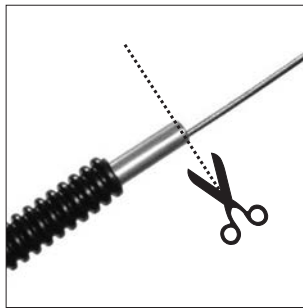

TIP

* For easier measurement of the correct cable length the special measuring pipe (Art. #8711) can be ordered. Simply place the measuring pipe as far down as possible over the cable. Cut the cable at the end of this pipe, then slide the new concertina tube over the pipe. Remove the measuring pipe, secure the male connector and the concertina tube in the correct positions.

1.3 Bajonet connector

ATTENTION

The new male bayonet connector (after-2005/Serial Number 43100) differs from the former as discribed below:

- 3mm Drilling (cable mount)
- Ring shaped groove (distinction characteristic)
- Cable end sheath

POINTER

Do not use the new cable sheaths together with the old bayonet connectors (2mm drilling) to clamp the cables. In this case, the cable sheaths will be squeezed flat and it will no longer be possible to remove them from the 2mm bayonet connectors.

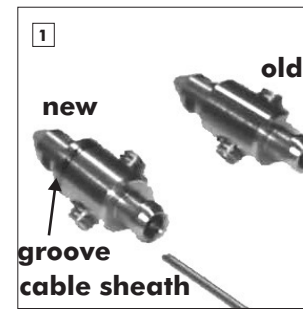

The bayonet connectors should be mounted together with the cable sheaths onto the 0.9mm hub cable. This way, damage to the cable by pinching it with the grub screws can be easily prevented.

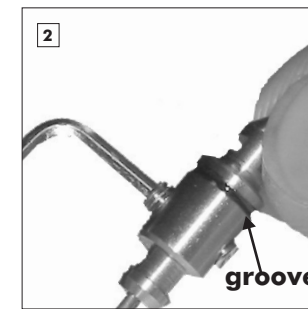

Insert the hub cable including the new cable sheath completely until the bedstop into the bayonet connector (3mm drilling). Fix the grub screws with a 2mm allen key.

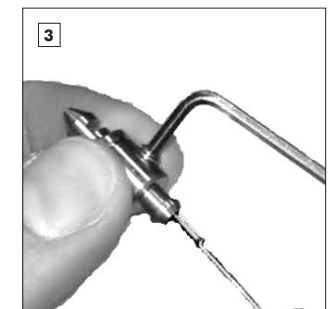

Use the 2mm allen key to secure the cable inside the bayonet connector with 0.8Nm. Secure the concertina tubes with cable ties. For further help, refer to "Repairs" 1.2.

1.3.1 New Bajonet version 2014

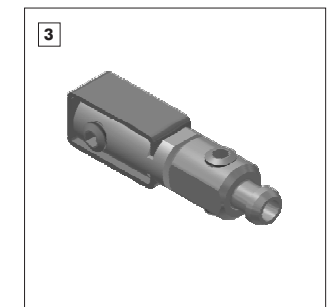
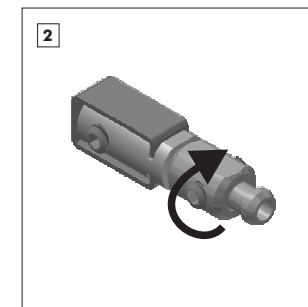
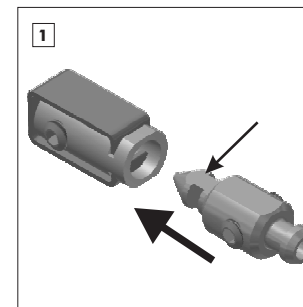

2. Changing the chain tensioner spring

Since the end of 2002 the *Rohloff* chain tensioner has been equipped with a modified spring. With the conversion kit (Art. #8248) all the older *Rohloff* chain tensioners can be equipped with the new spring.

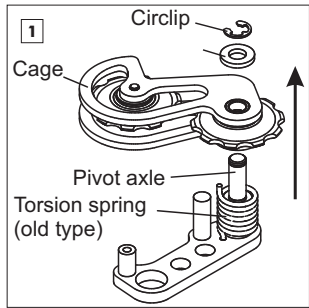

Remove the safety clip from the pivot axle using a flat screwdriver. Do not reuse this clip. Pull the cage and the washer off the pivot axle in the direction of the arrow. Remove the old torsion spring.

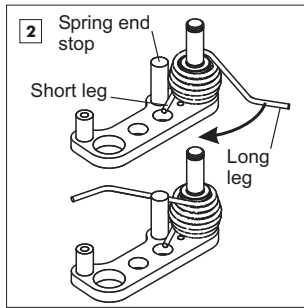

Clean and grease the pivot axle. Mount the new torsion spring over the pivot axle as shown. Turn the torsion spring until its short leg lies against the spring end stop. Hold the torsion spring in its position on the pivot axle whilst swinging the long leg over the spring end stop.

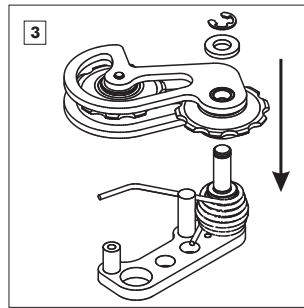

Push the cage completely onto the pivot axle. Replace the washer and fit the new safety clip into position.

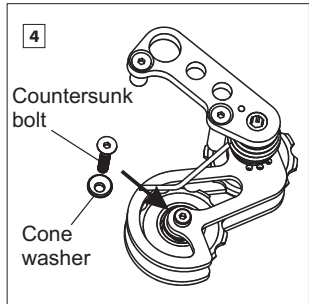

Bring the cage and the long leg of the spring together into a position similar to that shown in the diagram. Swap the old jockey wheel bolt for the new countersunk bolt (M4x20 - Torx TX20, tightening torque 3Nm/25in.lbs.) and cone washer.

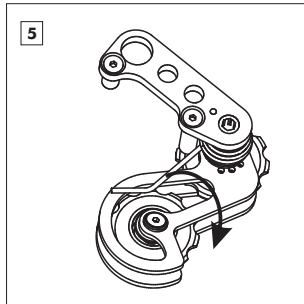

Push the long leg of the spring in the direction of the arrow over the new bolt and let it spring back.

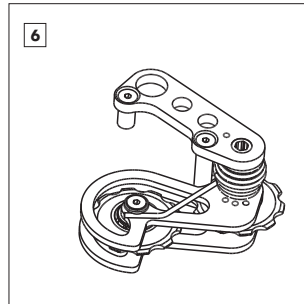

The long leg of the spring now sits against the cone washer and holds the cage back creating the tension.

POINTER

To replace the jockey wheels, remove the cage from the pivot axle (as in stage #1). Remove the lower jockey wheel bolt and replace the jockey wheels. Remount the chain tensioner (stages #3 and #4).

3. Changing the grip rubber

POINTER

The shifter cables have to be removed from the twist shifter first before it is possible to replace the rubber grip. Before the shifter cables are removed, the ends that were clamped in the female connectors (internal gear mech) or the cable pulley (external gear mech) must be cut so that the frayed ends of these cables do not damage the nylon liners when being removed.

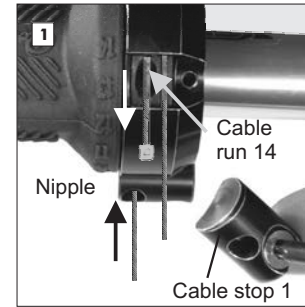

Remove cable stop 1 and rotate the twist shifter until the nipple of shifter cable 14 can be seen. Pull the cable out of the twist shifter. Repeat this process for the removal of shifter cable 1.

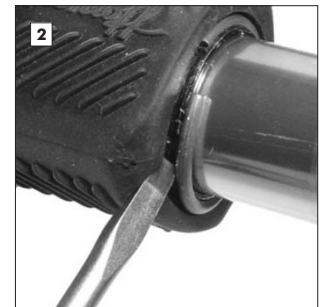

With a flat screwdriver, remove the safety ring. The rubber grip can now be removed. Clean the twist shifter housing.

TIP

Should only the rubber grip need to be replaced.

Firstly shift into gear #14. Disconnect the Bayonet Connectors or the External cable box. Screw both of the cable adjusters completely in and remove the two screws on the cable stops of the shifter. Remove the safety circlip and slide the complete rubber grip out of the shifter housing and off of the handlebars. Hook both the cables out of their seats in the rubber grip, transfer these and re-hook them into the new, lightly greased rubber grip (Art.N° 8201). Wind these cables roughly 3/4 (270°) around the new grip in their respective runs and slide this new complete unit back inside the shifter housing and refit both of the cable stops. Replace the safety circlip and lightly test the shifter functions correctly. Reconnect the Gear mech in gear #14.

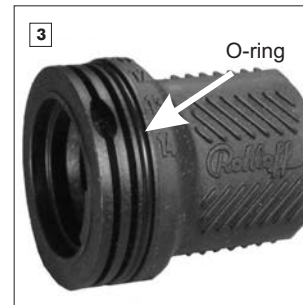

Lightly grease the twist shifter housing. The arrowed "O ring" must also be lightly greased and checked that it is sitting in the correct position before remounting.



The safety ring can now be remounted. Check that the twist shifter rotates smoothly and freely. Refit new shifter cables (see chapter "Mounting", paragraph 6. "Twist shifter").

4. Exchanging the gear unit

With the Rohloff SPEEDHUB 500/14, the 14 speed gearbox can be removed completely from the hub casing allowing for a quick and easy replacement of the gearbox.

4.1 Gear unit removal



The removal procedure must start with the rinsing and draining of the oil from within the hub (see chapter "Oil change"). The drain screw must not be reused.

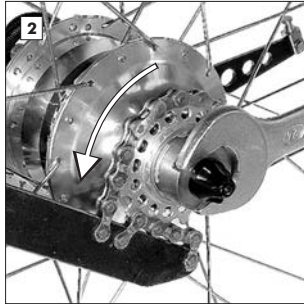

Remove the sprocket using a chain whip and the sprocket tool (see chapter "Service", paragraph 3. "Sprocket reversing/replacing").

ATTENTION !

When mounting or dismounting the sprocket, always check that the sprocket tool is properly secured. The driver could get severely damaged, when attempting this removal/assembly procedure with an unsecured sprocket tool.

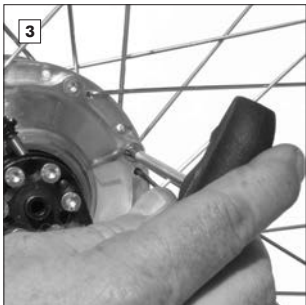

Remove the axle nuts or Q/R skewer and the sprocket tool. Now remove the 8 hub cap countersunk bolts (M4x10 - Torx TX20).

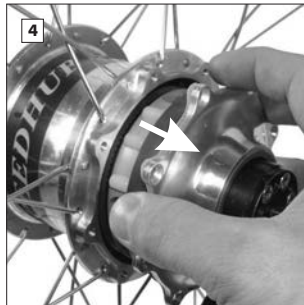

Draw the gearbox out of the hub casing. If this proves to be difficult, than gently tap the sprocket side of the gearbox with a rubber mallet to ease the process. CAREFUL! Excess oil could still leak out of the hub casing!



Lie the gearbox on its side and remove and dispose of the excess oil that is sitting in the hub casing.

4.2 Gear unit installation

When remounting the gearbox, new joints and a new paper gasket must be fitted.

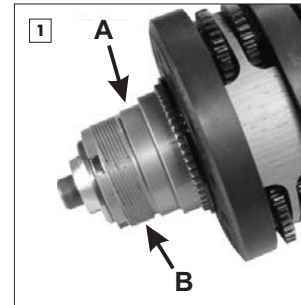

The bearing seat **A** and the sprocket thread **B** of the driver must be lightly greased before remounting the gearbox.



The new paper gasket (arrowed) must be fitted over the centering ridge of the hub cap. This is better accomplished when lightly greased. Align the holes in the paper gasket with those in the hub cap ready for the bolts later.

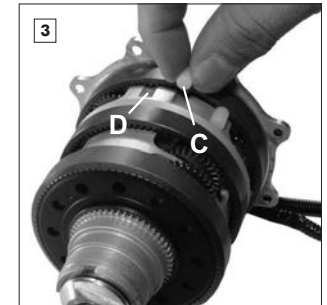

The new joints **C** must also be lightly greased before being placed into their respective seats **D**. These joints are what transfere the power from the gearbox to the hub casing.



Hold the hub cap and the gearbox firmly and feed the gearbox into the hub casing until the hub cap touches the hub casing.

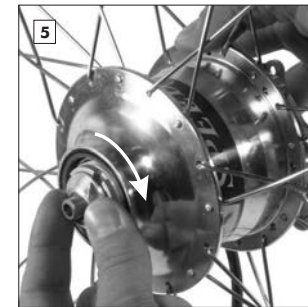

The gearbox only sits properly once the joints sit in their correct positions against the hub casing. To ease the process, rotate the driver in clockwise direction whilst pushing the two parts together.

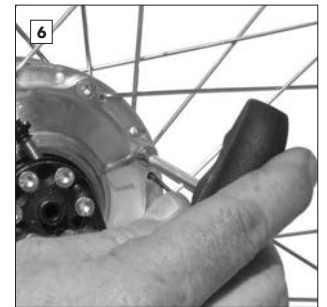

Once the hub casing touches the cap, the 8 countersunk screws can be replaced. Tighten these screws in a cross formation, so as to evenly distribute the pressure between the two parts whilst securing them together (M4x10 - Torx TX20, tightening torque: 3Nm/25in.lbs.).

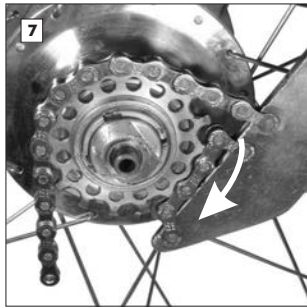

Refit the sprocket with the use of a chain whip.

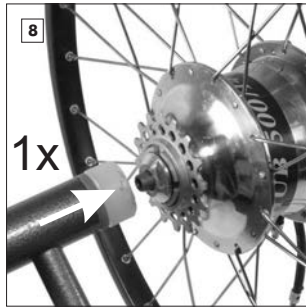

Check that the sprocket runs smoothly by spinning the sprocket backwards. If not, then hit the axle peg firmly with a rubber mallet. Once from the sprocket side (right) and once from the axle plate side (left). This will loosen-up the tension on the bearings.

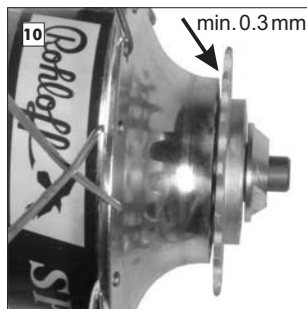

There must be a minimum of 0.3mm between the sprocket and the hub casing. If not, then remove the sprocket and push the hub seal as far back as possible. Refit the sprocket and check that the sprocket runs smoothly.



Refill the Rohloff SPEEDHUB 500/14 with 25ml of Rohloff SPEEDHUB OIL (see chapter "Service", paragraph 1. "Oil change") and refit a new drain screw (3mm allen key, tightening torque: 0.5Nm/4in.lbs.).

ATTENTION

The oil drain screw must not be inserted any further than flush with the hub shell. Any deeper could result in periodic drive loss in certain gears.



POINTER

The hub bearing within the hubshell is a fixed bearing and the hub bearing on the sprocket side is a movable bearing. During the replacement of the gearbox, the movable bearing could get strained (the outer race does not move parallel with the inner race due to friction created against the hub casing). By hitting the axle pegs with a rubber mallet, the inner and outer races of the bearing will be brought back into line. The sprocket should spin freely when rotated backwards once it is correctly seated.

POINTER

Further disassembly past the removal of the gear unit from the hub shell is not permitted. Failure to comply will result in the loss of warranty/guarantee.

5. Hub seal replacement with Shaft seal replacement tool (Art. #8503) and removal hook (Art. #8507)

The hub seals should only be replaced by a professional bicycle workshop in the case of oil leakages. The new hub seals (after Serial Number 25400) with an outer metal ring can only be replaced by Rohloff dealers with the hub seal replacement tools.

Shaft seal press-in tool

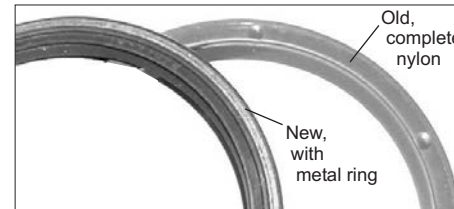
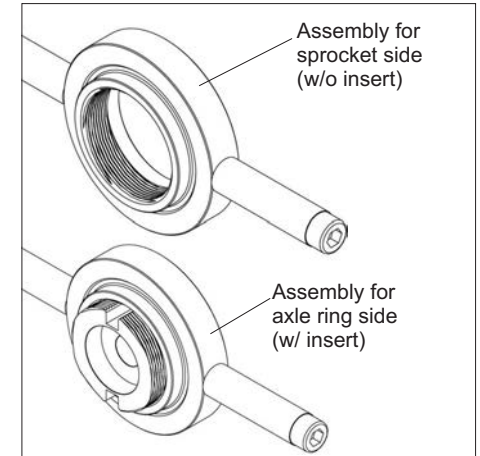
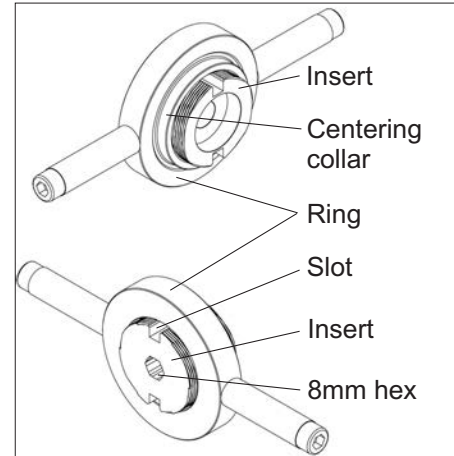

Check which type of hub seal is mounted within your hub. Hubs produced after Serial Number 25400 are equipped with the new hub seal. To be sure: The new hub seals have an outer metal ring and can therefore be replaced with the tools shown. The older types are completely formed from nylon, hubs needing these types of seals to be replaced, must be sent back to Rohloff Service department to be replaced.

5.1 Axle ring side:

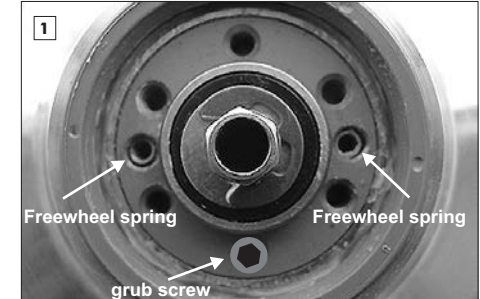

Lie the wheel on a flat surface with the sprocket side facing down. Remove the axle plate and the corresponding gear mech - a brake disc may have to be removed for this procedure.

ATTENTION

Make sure the two freewheel springs stay in the locating peg holes.

The grub screw mounted on hubs produced after Serial Number 47000 must be removed before replacing the hub seals and replaced again afterwards. See "Appendix" Grub screw, external gear mech.



Groove

ATTENTION !

If the rub-ring of the axle ring shows signs of damage (grooves within the outer surface, noticeable with a fingernail), then please post the axle ring to the Rohloff service department so that a new rub-ring can be mounted.

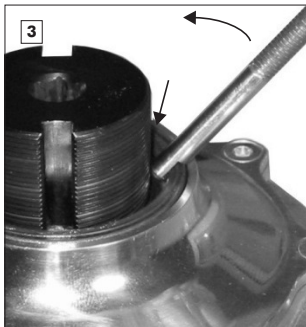

Remove the old hub seal from the hub shell. To do this place the insert onto the hub and hook the removal tool under the old hub seal. Lever the removal tool into the upright position as shown in the picture.



Remove the old hub seal by sharply pulling the removal tool upwards. If this doesn't remove the seal from the hub shell, then follow the method shown below.

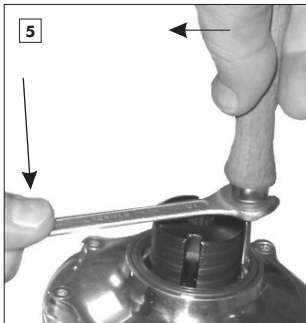

Lay a 10mm wrench flat over the insert with the open end hooked under the wooden grip of the removal tool. Secure the removal tool by pushing it against the insert. Force the wrench down onto the insert in order to lever the removal tool with the old hub seal upwards and out of the hub shell. Remove the insert.

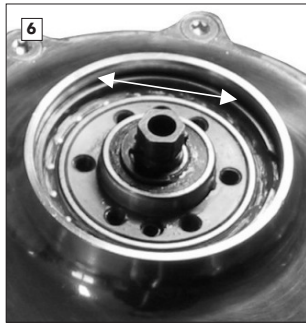

Use a cottonbud to clean and degrease (petroleum/brake cleaner) the mating surface ready for the new hub seal.



Prepare the hub seal press tool as shown in the picture.



Place the new hub seal around the centering collar of the press tool.

POINTER

The closed side of the new hub seal faces towards the tool itself, the open side is visible.

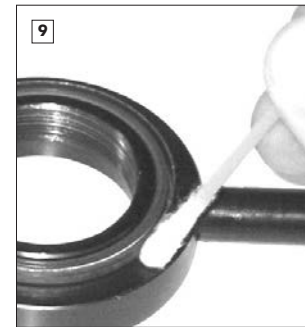

Using a cottonbud, cover the outside edge of the new hub seal with a thin coat of Loctite 641.

ATTENTION !

Make sure that none of the Loctite finds its way into the groove of the new hub seal.

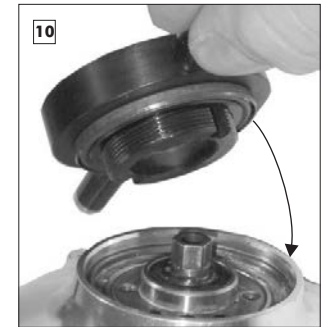

Place the press tool onto the hub with the new hub seal facing inwards.

POINTER

The grub screw on hubs after Serial No. 47000 must be removed in order to guarantee a flush mounting of the Hub Seal.

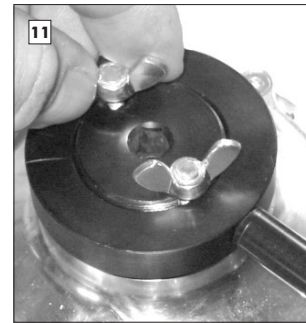

Thread the two included wingbolts through the square slots on opposite sides of the press tool, secure these in the holes of the hub left and right of the axle.

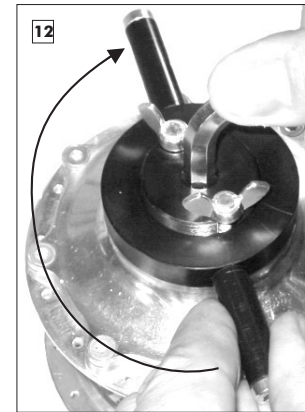

Turn the press tool clockwise as far as possible whilst holding the insert still with an 8mm allen key. The new hub seal will now be pressed firmly into the correct position.

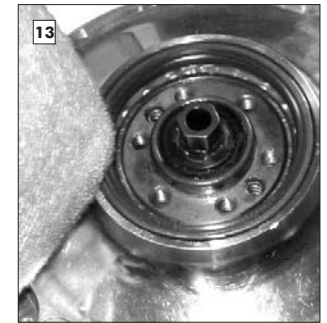

Wind the press tool back to its normal position. Remove the press tool and wing bolts. Clean away any Loctite that has overspilled onto the hub shell.

5.2 Sprocket side:

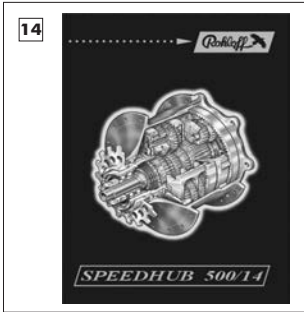

Replace the axle plate and the gear mech using new paper gaskets as shown in the Owners Manual.

Axle plate position
 "Mounting 4"
 Internal gear mech
 "Repairs 1.1 + 1.2"
 External gear mech
 "Service 5.3"

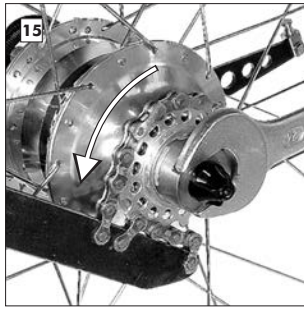

Remove the sprocket as shown in the Owners Manual. Lie the wheel on a flat surface with the sprocket side facing up (Service 5.3)

ATTENTION

Oil could leak out once the sprocket is removed.

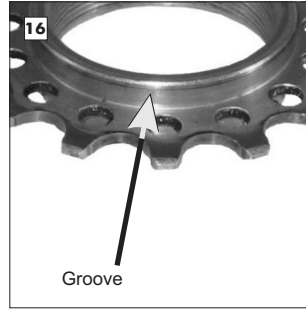

ATTENTION

Check the sprocket for signs of wear. If it is worn then rotate it before remounting (see Owners Manual). When both sides are worn then replace it for an unworn sprocket with undamaged seal surfaces.

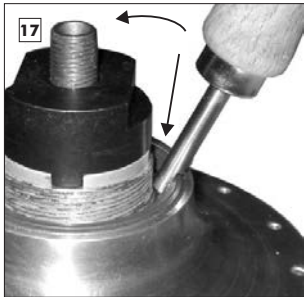

Remove the old hub seal from the hub shell. To do this place the sprocket tool onto the driver and hook the removal tool under the old hub seal. Lever the removal tool into the upright position as shown in the picture.

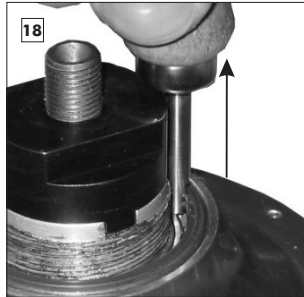

Remove the old hub seal by sharply pulling the removal tool upwards. If this doesn't remove the seal from the hub shell, then follow the method shown below.

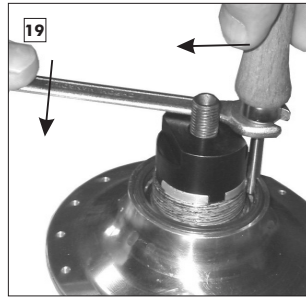

Lay a 10mm wrench flat over the sprocket tool with the open end hooked under the wooden grip of the removal tool. Secure the removal tool by pushing it against the sprocket tool. Force the wrench down onto the sprocket tool in order to lever the removal tool with the old hub seal upwards and out of the hub shell. Remove the insert.

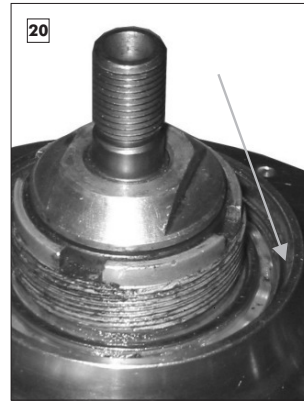

Clean and degrease (petroleum/brake cleaner) the mating surface ready for the new hub seal.

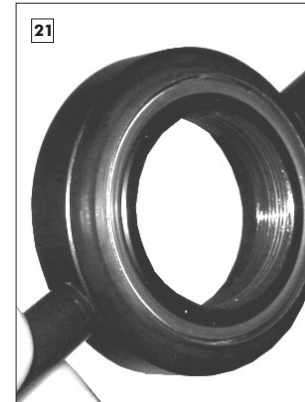

Place the new hub seal around the centering collar of the press tool. The closed side of the new hub seal faces towards the tool itself, the open side is visible.

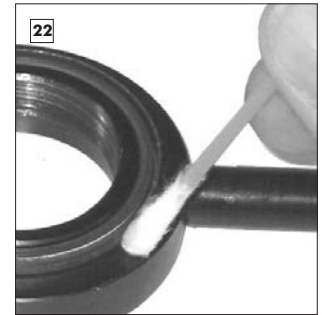

Using a cottonbud, cover the outside edge of the new hub seal with a thin coat of Loctite 641.

ATTENTION

Make sure that none of the Loctite finds its way into the groove of the new hub seal.

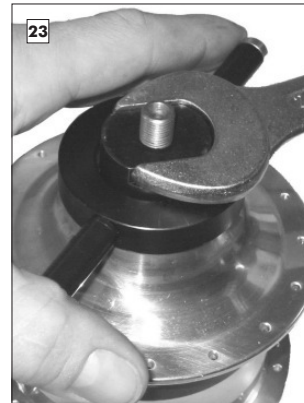

Place the sprocket tool onto the driver and secure it in position with the Q/R skewer or an axle nut. Set the ring over the sprocket tool and thread it clockwise as far as possible over the thread of the driver whilst holding the sprocket tool still with an 24mm wrench. The new hub seal will now be pressed firmly into the correct position.



Remove the ring and the sprocket tool.



Replace the new/rotated sprocket (with undamaged seal surfaces) as shown in the Owners Manual.

POINTER

The metal part of the hub seals should be flush with the edge of the hub shell and/or hub cap.

Trouble shooting

Problems and possible reasons	Solution
<p>1. Too much play in the twist shifter (more than 2mm)</p>	<p>Readjust the cable tension, see "Service" 2.</p>
<p>2. Gear display is not aligned correctly</p>	<p>Alter the cable adjusters, see "Service" 2.</p>
<p>3. Twist shifter will not turn through all 14 gears (14 gears = 13 clicks)</p> <p>3.1 Shifter cables cut at the wrong length</p> <p>3.2 Falsely altered cable adjusters</p> <p>3.3 For external gear mech: Hexagonal peg of the gear transfer box in an incorrect position</p>	<p>Cut cables to the correct length: - Internal gear mech, see "Mounting" 7.2.1 - External gear mech, see "Mounting" 7.3.1</p> <p>Alter the cable adjusters, see "Service" 2.</p> <p>Correctly align the hexagonal peg see "Riding with the SPEEDHUB 500/14" 3.2</p>
<p>4. Twist shifter does not turn freely</p> <p>4.1 Cable tension is too high</p>	<p>Reduce the shifter cable tension, see "Service" 2.</p> <p>Check the internal gear mech: Open the bayonet connectors and (holding a cable in each hand) pull the cables in turn. They run smoothly, see points 4.2 - 4.6. They do not run smoothly, see point 4.7.</p> <p>Check the external gear mech: Select gear #14. Remove the cable box just enough so that the twist shifter can be turned without force and the cables keep their normal routing bends. Turn the twist shifter back and forth. It does not turn smoothly, see points 4.2 - 4.6. It turns smoothly, see point 4.8.</p>

Problems and possible reasons	Solution
<p>4.2 Shifter cables worn, dirty or damaged</p> <p>4.3 Incorrect shifter cables fitted (not original Rohloff)</p> <p>4.4 Cable routing has too many bends or kinks</p> <p>4.5 Inner nylon liners have penetrated into the twist shifter or the cable box (due to a false fitment)</p> <p>4.6 Twist shifter rubs against the grip itself</p>	<p>Fit new shifter cables: - Internal gear mech, see "Mounting" 7.2 - External gear mech, see "Service" 2.</p>
<p>4.6.1 Twist shifter degreased by weather</p>	
<p>4.7 Hub cable broken and frayed</p>	
<p>4.8 Gear transfer box (external gear mech) is bent</p>	
<p>4.8.1 Changing between gears 8 and 14 is not possible or only possible with extreme force</p>	
<p>4.9 Hexagonal peg of the external gear mech does not turn freely (due to corrosion)</p>	<p>Leave a small gap between the twist shifter and the grip or insert a teflon washer between the two parts.</p> <p>Remove the twist shifter grip rubber, clean it, and regrease it. See "Repairs" 3.</p> <p>Check the shifter cables: Loosen the concertina tubes at the hub and pull them up towards the bayonet connectors. Check the condition of these cables in gear positions 1 and 14. If the hub cable is damaged, it will need replacing: - One-piece axle ring, see "Repairs" 1.1 - Quick-change axle ring, see "Repairs" 1.2</p> <p>Replace the gear transfer box</p> <p>Mounting, see "Service" 5.3</p> <p>Grub screw (after hub Nr 47000 with an external gear mech) is threaded too far into the axle. This must be unscrewed approx. 2mm. See "Appendix".</p> <p>Checking: Place an 8mm wrench over the hexagonal peg of the external transfer box. When using the wrench to switch gears, the changing of gears must have a light and positive feel. If not, remove the external transfer box. Regrease the hexagonal peg and the sprocket ("Service" 5.3).</p>
<p>4.9.1 The cable pulley of the external gear mech doesn't turn freely (after the conversion from an internal to an external gear mech)</p>	<p>Check: The correct position of the cog D over the hexagonal peg E. See "Service" 5.3</p>

Problems and possible reasons

Solution

5.) Twist shifter fails to turn in 0° temperatures.

- 5.1 Water has penetrated into the twist shifter and has frozen
- 5.2 Water has penetrated into the shifter cables and has frozen
- 5.3 Water has penetrated into the cable box and has frozen

Remove the rubber grip. Clean, regrease this and when necessary replace the seal, see "Repairs" 3.

Replace the shifter cables and the nylon liners:
 - Internal gear mech, see "Mounting" 7.2
 - External gear mech, see "Mounting" 7.3

Open the cable box, clean this and replace the cable pulley with a little light grease.
 Fitment, see "Mounting" 7.3.1

Cut off the frayed ends of the shifter cable and trim the cable housing/nylon liner by the same amount. Alternative: fit new cables:
 - Internal gear mech, see "Mounting" 7.2
 - External gear mech, see "Mounting" 7.3

6.) Shifter cable is loose from the cable clamp
 (Bayonet connectors on internal gear mech or cable pulley on external gear mech)

Replace hub cable:
 - One-piece axle ring, see "Repairs" 1.1
 - Quick-change axle ring, see "Repairs" 1.2

7.) Male bayonet connector is loose from the hub cable

Loosen up the stiff link or replace the chain

Rotate or replace the sprocket, replace the chain, see "Service" 3.

8.) Chain springs over the teeth of the sprocket

- 8.1 Chain defect (stiff chain link)
- 8.2 Worn sprocket or chain
- 8.3 Not enough tension in the chain

Correct the chain length/tension, see "Mounting" 5.3

9.) On bikes with a chain tensioner, the chain springs off the sprockets

- 9.1 Chain tensioner runs dry and turns with difficulty
- 9.2 Chain tensioner spring is defect
- 9.3 No chain guide in use

Grease the chain tensioner or replace the jockey wheels, see "Service" 2. or "Repairs" 2.

Replace the chain tensioner spring, see "Repairs" 2.
 Check the min. chain length on full suspension bikes, see "Mounting" 5.3.1

Mount a chain guide, see "Mounting" 5.4
 All bikes fitted with a chain tensioner need to be fitted with a chain guide (eg Rohloff chain guide CC Art. #8290). This prevents the chain from springing off the chainring.

Problems and possible reasons

Solution

10.) Freespinning (after a gear change)

- 10.1 Axle nuts (CC/TS axle) too firmly tightened
- 10.2 Shifter cable tension is too high. No positive feel to the gear change
- 10.3 Gearbox oil too thick
- 10.4 Axle fixation with a PITLOCK or allen key system
- 10.5 None of the above: Contact the Rohloff Service team

Tighten axle nuts to the correct tightening torque (CC 7Nm/ 60in lbs / TS 35Nm/310in.lbs.)

Adjust shifter cable tension, see "Service" 2.

Test: Add Rohloff special oil change assistent fluid to the oil within the hub and go for a test ride
 No more freespinning? Carry out an oil change, see "Service" 1.

Tighten the axle to 7Nm /60 in.lbs.max. torque (pay attention to the manufacturers advice)

11.) Freespinning (after a gear change) below 0°C

- 11.1 Gearbox oil too thick
- 11.2 Riding the bike below -15°C

Carry out an oil change with an intensive rinsing, see "Service" 1.

Rinse the gear-unit and refill the hub with a 50:50 mixture of All Season Oil and Cleaning Oil (total fill quantity - 25ml)

12.) Freespinning of gears #1 to #7 after removing the axle ring or the external transfer box

Check that the two freewheeling springs are there and sitting in the correct holes, see "Repairs" 1.1 and "Service" 5.3

13.) Freewheel does not rotate smoothly

- 13.1 Hub seal rubs against the sprocket
- 13.2 Strained hub bearings (crash or accidents)
- 13.3 Chain Tension too high

Test: The sprocket must rotate backwards freely without restriction

Push the hub seal back (until Serial.No. 25299 possible) see "Repairs" 4.2

Destrain the hub bearings, see "Repairs" 4.2

Reduce the chain tension to about 5mm of vertical slack, replace or reverse untrue chainrings.

Problems and possible reasons

Solution

- 14. Oil leaks
 - 14.1 Oil traces (no droplets)
 - 14.2 Oil leaks following horizontal transportation
 - 14.3 Oil traces on the quick release skewer
 - 14.4 Oil drops out of the hollow quick release axle
 - 14.5 Oil droplets on the axle ring, the axle plate or the concertina tubes
 - 14.6 Oil droplets between the hub casing and the hub cap
 - 14.7 Oil traces around the oil drain screw
 - 14.8 Oil droplets on the hub bearings (Both ends of the hub smeared with oil)

This is not an oil leak. This is sweat oil, which forms around the hub bearing, the paper gasket and the oil drain screw due to variations in air temperature and pressure.

See "Riding with the SPEEDHUB 500/14"

The ventilation functions through the axle hole for the quick release skewer. Oil traces on the quick release skewer are, therefore, normal

Please contact the Rohloff Service team

Check the axle plate screws are all in place and tightened to the correct tightening torque. (see "Mounting" 4.3) Renew the paper gaskets between the axle ring and the axle (see "Service" 5.3 or "Repairs" 1.1) Only use Rohloff axle plate screws with thread sealant

Check the hub cap screws are all in place and tightened to the correct tightening torque, see "Repairs" 4.2

Use new thread sealant on the oil drain screw (Loctite thread sealant 511) or a new oil drain screw with Rohloff thread sealant, see "Service" 1.

Please contact the Rohloff Service team

15. **Complete blockage of the gear system after working on the external gear mech**

The grub screw (mounted in hubs after Serial Number 47000 with an external gear mech) is screwed too far into the axle. This must be unscrewed approx. 2mm. See "Appendix", Grub screw external gear mech.

ATTENTION

Too much oil within the gearbox increases the risk of oil leaks. Therefore, when an oil leak is discovered, new replacement oil must not be added (risk of overfilling). Reduced oil level by leakage through the seals will not cause problems and riding further until the next oil change (annually or every 5000km) is possible (see "Service" 1).

Tools and bolts

Below is a list of all tools and bolts (along with their corresponding tightening torques) for the mounting of the Rohloff SPEEDHUB 500/14 and its accessories.

- Torx TX20 wrench (Art. #8504)***
 Rohloff SPEEDHUB 500/14:
 8 or 9 Hub cap screws: M4x10 (3Nm/25"lbs.)
 5 or 6 Axle plate screws: M4x25 (3Nm/25"lbs.)
 2 Cable box cover bolts: M4x10 (3Nm/25in-lbs.)
- External gear mech:*
 2 Guide pin bolts: M4 (3Nm/25in-lbs.)
- Twist shifter:*
 2 Cable guide bolts: M4x16 (3Nm/25in-lbs.) version 8200
 2 Clamp bolts: M3x12 (2Nm/16in-lbs.) new version 8206
- Rohloff chain tensioner/DH chain tensioner:*
 2 End stop bolts (DH: just one): M4x10 (3Nm/25in-lbs.)
 Jockey wheel axle bolt: M4 (3Nm/25in-lbs.)
- Rohloff chain guide CC:*
 Bolt (rear distance bush): M4x20 (3Nm/25in-lbs.)
 Bolt (rear threaded bush): M4x20 (3Nm/25in-lbs.)
 Bolt (rear threaded bush): M4x35 (3Nm/25in-lbs.)
 2 Clamp bolts: M4x35 (3Nm/25in-lbs.)
- 2mm allen key**
Internal gear mech:
 8 Bayonet connector bolts: M4x4
- External gear mech:*
 2 Cable pulley bolts: M4x4
- Rohloff DH chain guide:*
 3 Mounting bolts: M4x8
- 2.5mm allen key**
 Rohloff SPEEDHUB 500/14:
 Twist Shifter (old version) Art. #8200 (0,5Nm/4in-lbs.)
- 3mm allen key**
 Rohloff SPEEDHUB 500/14:
 Oil drain screw (0,5Nm/4in-lbs.)
- 4mm allen key**
 Rohloff SPEEDHUB 500/14:
 Cable guide mounting bolt: M6 (6Nm/51in-lbs.)
- TS versions:*
 Torque arm clamp bolt: M6x12 (6Nm/51in-lbs.)
- Rohloff SPEEDBONE / MonkeyBone:*
 2 Mounting bolts: M6x25
- 5mm allen key**
 Rohloff SPEEDHUB 500/14:
 4 or 5 Chainring bolts: M8x0.75 (10Nm/87in-lbs.)
- DB versions:*
 4 brake disc mounting bolts: M8x0.75 (7Nm/61in-lbs.)
- Retrofit versions (not OEM or OEM2):*
 2 Torque arm mounting bolts: M8 (7Nm/61in-lbs.)
- Rohloff chain tensioner/DH chain tensioner:*
 Mounting bolt (8Nm/70in-lbs.)
 Pivot axle (8Nm/70in-lbs.)
 (Attention: Turning clockwise unscrews)

- 7mm wrench**
 Rohloff chain guide CC:
 M4 Nut, rear distance bush
- 8mm wrench**
 Shifting shaft
- 10mm wrench**
TS versions:
 Torque arm clamp nut
 Cable guide 0°
 Frame clamp nut
- 13mm wrench**
Internal gear mech:
 Cable guide
- 15mm wrench**
TS versions:
 2 TS axle nuts: M10 (35Nm/310in.lbs.)
- Screw driver**
CC versions:
 2 clamps (5Nm/43in.lbs.)
- 17mm wrench**
 Locking nut (holding the axle steady)
- 24mm wrench**
 for sprocket tool
- Sprocket tool (Art. #8501)**
 Sprocket removal
- Chain whip**
 Sprocket removal
- Brass tube 165mm (Art. #8711)**
 Cutting hub cables (internal gear mech)
- Brass tube 200mm (Art. #8712)**
 Cutting shifter cables (external gear mech)
- Shifter cable measurement tool (Art. #8506)**
 Cutting shifter cables (internal gear mech)

POINTER

* The use of Torx screws/bolts as opposed to the common allen key bolts allows a more safe and nondestructive mounting and dismantling without the heads rounding out after several times usage. To avoid damaging the heads of the screws/bolts, the Torx key must be securely pressed into the head. We suggest the use of a T-grip key to keep the pressure central over the bolt (the use of other tools could result in damage to the bolts).



Wheel lacing for rims with a European spoke-hole pattern

The following written wheel lacing method always concentrates itself around the directional rotation of the wheel, the method also only applies to wheels with a two cross lacing pattern.

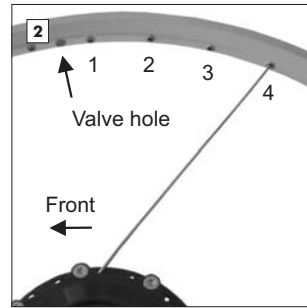
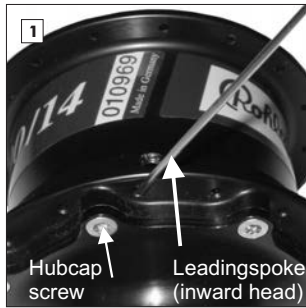

Start to lace up the wheel from the hubcap side of the hub. The first leading spoke should be inserted from the inside of the hub flange behind a hubcap screw (spoke head facing inwards).

The end of this spoke should be inserted into the nipple hole of the rim that is 4 holes away from the valve hole.

POINTER

Trailing spokes cross in front of Leading spokes.
Leading spokes cross behind the Trailing spokes.

ATTENTION

Further information on correct spoke lengths and tension (mind. 1000N with inflated tire) can be found in the section 'The Wheel' and also in the Appendix.

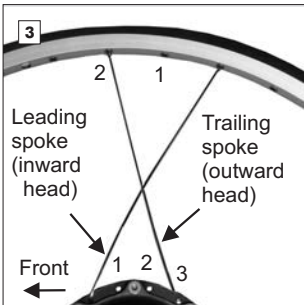

Three holes (one hole) behind this first spoke is where the trailing spoke should be inserted, this spoke is to be inserted from the outside of the hub flange (spoke head facing outwards). This spoke is to be crossed over the first spoke and inserted into the nipple hole of the rim that is two holes before that of the first spoke.

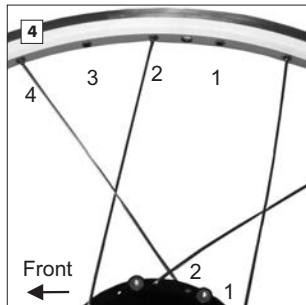

The next trailing and leading spokes are laced into the rim in exactly the same way. The only difference being that they enter the hub flange two holes away from the last respective leading or trailing spoke, and that they enter the rim four holes away from the last respective spokes. Continue this process in pairs of leading and trailing spokes until all the spokes have been laced into the hubcap side of the wheel. Turn the wheel over.

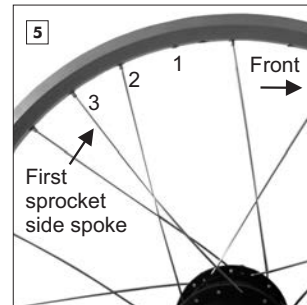

The valve hole is to be found opposite from a hubcap screw. The spoke hole of the flange opposite from this is where the first spoke on the sprocket side is to be inserted from the inside (spoke head facing inwards). This spoke is to be inserted into the nipple hole of the rim that is 3 holes behind the valve hole. Lace all the remaining spokes in the same pattern as with the other side of the wheel (Fig. 3 and 4).

POINTER

Flange Support Rings should be Fitted to each spoke flange before lacing wheels. These rings prevent total loss of all spoke tension even if the aluminum flange were to fail.

Appendix



Wheel lacing for rims with a French spoke-hole pattern

The following written wheel lacing method always concentrates itself around the directional rotation of the wheel, the method also only applies to wheels with a two cross lacing pattern.

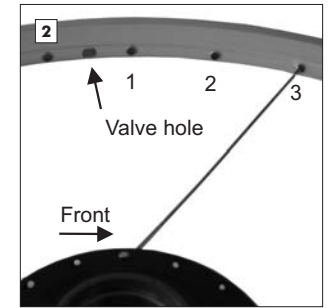
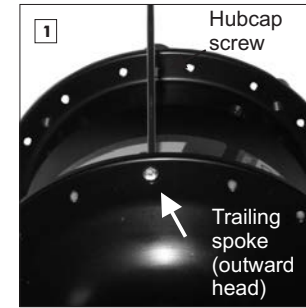

Start to lace up the wheel from the sprocket side of the hub. The first trailing spoke should be inserted from the outside of the hub flange opposite a hubcap screw (spoke head facing outwards).

The end of this spoke should be inserted into the nipple hole of the rim that is 3 holes away from the valve hole.

POINTER

Trailing spokes cross in front of Leading spokes.
Leading spokes cross behind the Trailing spokes.

ATTENTION

Further information on correct spoke lengths and tension (mind. 1000N with inflated tire) can be found in the section 'The Wheel' and also in the Appendix.

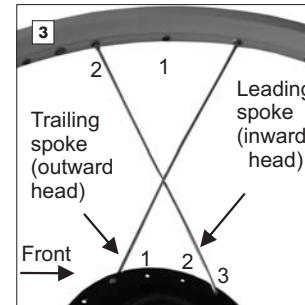

Three holes (one hole) behind this first spoke is where the leading spoke should be inserted, this spoke is to be inserted from the inside of the hub flange (spoke head facing inwards). This spoke is to be crossed over the first spoke and inserted into the nipple hole of the rim that is two holes behind that of the first spoke.

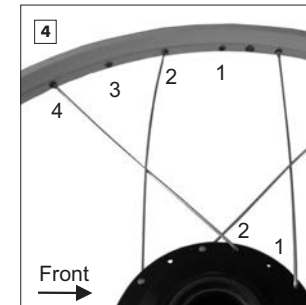

The next trailing and leading spokes are laced into the rim in exactly the same way. The only difference being that they enter the hub flange two holes away from the last respective pull or cross spoke, and that they enter the rim four holes away from the last respective spokes. Continue this process in pairs of leading and trailing spokes until all the spokes have been laced into the sprocket side of the wheel. Turn the wheel over.

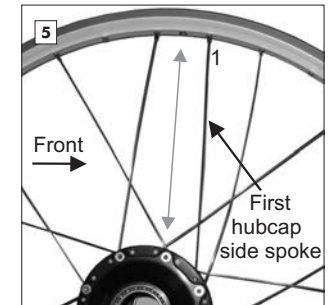

The valve hole is to be found opposite from a hubcap screw. The spoke hole of the flange that is two holes behind this, is where the first spoke on the hubcap side is to be inserted from the outside (spoke head facing outwards). This spoke is to be inserted into the first nipple hole of the rim that lies behind the valve hole. Lace all the remaining spokes in the same pattern as with the other side of the wheel (Fig. 3 and 4).

POINTER

Flange Support Rings should be Fitted to each spoke flange before lacing wheels. These rings prevent total loss of all spoke tension even if the aluminum flange were to fail.

Appendix

Technical data

Number of gears:	14
Gear increases:	even 13.6%
Range of gears:	526%
Frame spacing:	135mm (XL Version = 170mm/XXL Version = 190mm)
Number of spoke holes:	32/36 (XL/XXL Version = 32 hole only)
Spoke flange distance:	58mm, symmetrical (XL/XXL Version = 93mm)
Spoke hole circle diameter:	Ø100mm
Spoke hole diameter:	Ø2.7mm
Spoke flange width:	3.2mm
Axle diameter at dropout:	9.8mm
Axle overall width CC:	147mm (XL Version = 182mm/XXL Version 202mm)
Hollow axle inner diameter:	Ø5.5mm, for quick release lever
Total axle width TS:	171mm / TS long 179mm
Total axle width TS (XL Version):	206mm / TS long 214mm
Axle thread TS:	M10x1
Center disc mounting diameter:	Ø52mm
Mounting bolt hole circle diameter:	Ø65mm
Brake disc mounting bolts:	4 x M8x0.75
Distance between dropout and center disc mount:	16.3mm (Is1999)
Weight:	1700g (CC), 1800g (CC EX), 1825g (CC DB)
Weight (XL Version/XXL Version)	1980g (XL CC DB OEM2) / 2005g (XXL CC DB OEM2)
Oil volume:	25ml max.
Sprocket thread:	M34x6 P1, tolerance 6H
Sprocket type:	for bicycle chain 1/2" x 3/32" (ISO Nr. 082)
Number of sprocket teeth (16 standard):	13, 15, 16, 17 threaded- or 13-19 + 21 splined-sprocket
Chainline (135mm/142mm):	54mm (58mm for 13T & all splined sprockets)
Chainline (XL/XXL Version):	72mm (75mm for 13T & all splined sprockets)
Smallest permissible gear ratios : 40/21, 36/19, 34/18, 32/17, 30/16, 28/15, 28/14, 26/13 (transm.-factor ~ 1.90)	
(Riders over 100kg/tandem): 53/21, 48/19, 45/18, 42/17, 40/16, 38/15, 36/14, 34/13 (transm.-factor ~ 2.50)	
Gates Carbondrive beltline:	54.75mm (XL/XXL Version = 72)
Smallest permissible belt sprocket ratios (26"): 39/19, 39/20, 42/22, 46/24 (transmission factor ~ 1.90)	
(Riders over 100kg/tandem): 46/19, 50/20, 55/22, 60/24 (transmission factor ~ 2.50)	
Maximum input torque:	130Nm
Gear control:	by twist shifter (version right or left)
Twist shifter angle per gear change:	21°/273°
Gear control transfer:	via two shifter cables (pull-pull system)
Shifter cable movement per gear change:	7.4mm/96,2mm
Inner gear ratios (hub rotation per sprocket rotation):	
Gear #1:	0.279
Gear #2:	0.316
Gear #3:	0.360
Gear #4:	0.409
Gear #5:	0.464
Gear #6:	0.528
Gear #7:	0.600
Gear #8:	0.682
Gear #9:	0.774
Gear #10:	0.881
Gear #11:	1.000
Gear #12:	1.135
Gear #13:	1.292
Gear #14:	1.467

The Rohloff AG reserves the right to change the technical specifications without prior warning.

Reference to Serial Number of the Rohloff SPEEDHUB 500/14

ATTENTION Serial Number

Each Rohloff SPEEDHUB 500/14 is provided with a consecutive Serial Number which is found on the sticker band around the hub shell. SPEEDHUBs built after Serial Number 75000, have the Serial Number engraved directly into the hub shell.

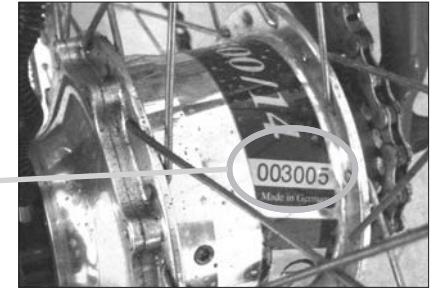

TIP Sticker

If the tape around the hub shell should be removed at any time, we recommend to separate first the Serial Number with a sharp carpet knife from the tape and then to leave just this Serial Number on the hub. If the tape should be removed completely, the Serial Number should be saved and/or stuck onto the warranty card. Alternatively, the Serial Number can be engraved on the hub cap!

POINTER Warranty Card

Each SPEEDHUB 500/14 and each complete bicycle equipped with the SPEEDHUB 500/14 comes complete with an orange Rohloff warranty card attached.

This orange Rohloff warranty card must be:

- completed in full (with Serial Number!)
- stamped by the dealer
- returned to Rohloff AG, Germany

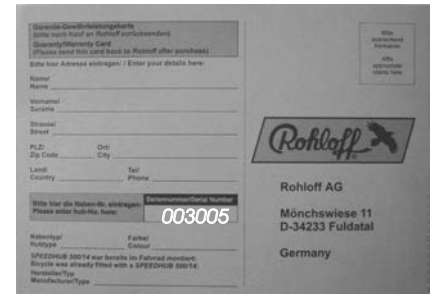

This Rohloff warranty card is vital to ensuring we can provide your hub with the best possible service.

ATTENTION Warranty

This Serial Number informs us about the production year and is important for guarantee or warranty claims, as well as acting as proof of ownership.

Only with knowledge of the appropriate Serial Number can an optimal service can be completed by Rohloff.

Consecutive Serial Number - Production Year		
000000 - 000400		1998
000401 - 002700		1999
002701 - 006500		2000
006501 - 012000		2001
012001 - 018800		2002
018801 - 027700		2003
027701 - 038500		2004
038501 - 050049		2005
050050 - 065000		2006
065001 - 081600		2007
080601 - 100000		2008
100001 - 115900		2009
115901 - 135800		2010
135801 - 152800		2011
152801 - 172499		2012
172500 - 191398		2013
191399 - 206999		2014
207000 - 223999		2015
224000 - 241130		2016
241131 -		2017

We expressly point out that the Rohloff AG does not accept any warranty claims for Rohloff SPEEDHUB 500/14 gearhubs without a Serial Number. Service, repairs, and the spare parts service will also only be carried out on hubs when the hub is presented with the corresponding Serial Number (either on the sticker, engraved into the hub shell, or on the warranty card).

Grub screw of the External Gear Mech

All gear hubs built after Serial Number 47000 and equipped with an external gear mech have an M4x8 grub screw mounted into the sixth threaded hole of the axle (it helps to prevent potential oil leaks). Therefore, the external gear mech can only be properly fitted in one position (PFig. 2) over the axle.

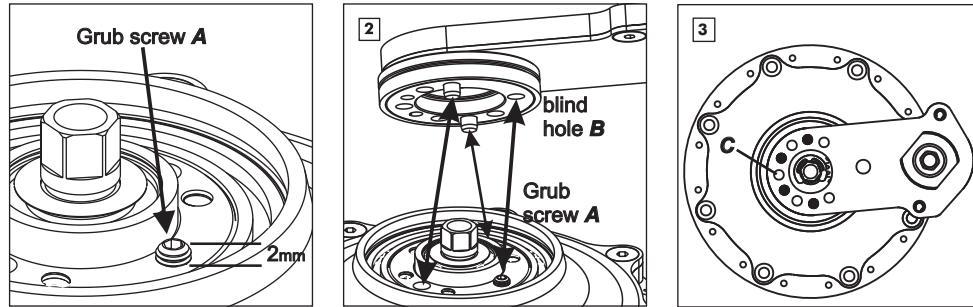

The grub screw on hubs with a Serial Number between 47000 and 48500 lies flush (external gear mech without a blind hole). On hubs with the Serial Number 48501 and over, this grub screw protrudes by approx. 2mm (external gear mech with a blind hole).

The blind hole (B) must be located directly over the grub screw (A). When using an external gear mech without a blind hole (B), the grub screw must be screwed flush into the axle. **The paper gaskets should then be fitted so that all the holes meet up with the corresponding screw holes of the axle.**

To control that the mounting is correct, the screw (C) must be screwed smoothly approx. 4 complete turns into the hub without force. Afterwards, the installation of the axle plate including all the screws can be completed (3Nm).

POINTER



If an axle plate screw cannot or only with force be screwed into hole (C), then it must be checked that the grub screw (A) is not sitting directly behind this hole. If this is the case, then the external gear mech must be disassembled turned around 180° and mounted again in this position. The grub screw stays in its original position (2mm protruding).

ATTENTION



If the external gear mech should be falsely mounted, then the fitting of an axle plate screw into hole (C) would cause the grub screw (A) to be forced into the axle. This in turn will lead to a complete blockage of the gearbox.

The removal of the grub screw is only necessary when converting the external to an internal gear mech, or when working with the hub seal replacement tools. The external gear mech should never be removed from the gearbox without good reason!



The correct spoke choice

There are a confusing amount of different spokes currently available on the market. These differ not only by their length and diameter, but also more importantly by the differences in the spoke bend at the head. To accomplish the optimal longevity of both the hub flange, the spoke itself and the entire wheel, the spoke bend dimensions must be harmonized with both the hub flange and the spoke holes. It is not sufficient enough to simply choose a spoke according to its length and diameter (eg. 2.0-256mm), the spoke bend itself must additionally be harmonized with the spoke hole so that the spoke can find its optimal sit within the spoke holes of the hub flange.

Pointer



Because retrofit spokes for the Rohloff SPEEDHUB 500/14 with the required head length of 2.9mm are only available in 2.0mm diameter, we generally recommend the use of DD 2.0/1.8/2.0mm spokes for lacing SPEEDHUB wheels.

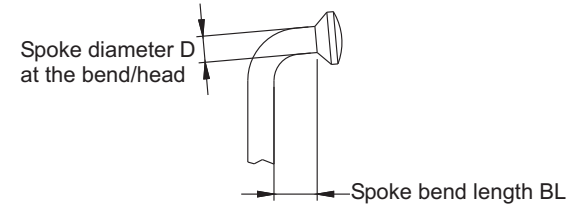

D	BL
2.0	2.9 +/-0.1

Problem 1

If the spoke bend is too long and/or the diameter of the spoke at this bend be too small, then this will result in the spoke having an amount of axial play after the wheel has been trued. The spoke bend can now be bent open, resulting in a possible spoke failure.

Problem 2

If the spoke bend is too short and/or the diameter of the spoke at the bend be too large, then the hub flange could become slightly deformed as the spokes are threaded into the hub shell or as the spokes are tensioned. The damage caused here could possibly lead to a flange breakage.

Checking the correct sit for the Rohloff SPEEDHUB

The hub flange and the spoke hole diameter on the SPEEDHUB 500/14 are designed so that an optimal sit can be achieved with the following spoke dimensions:

ATTENTION



As the required spoke head length of 2.9mm is currently only available on 2.0/1.8/2.0mm spokes, we generally advise the use of DD spokes of this size. Bicycle manufacturers who utilise thick spokes with an oversized head diameter when lacing SPEEDHUB wheels, must guarantee the correct length of each spoke head (3.7mm). The spokes should then be tensioned to a minimum of 1000N measured with an inflated tire or 1300N without tire.



The correct spoke geometry can be easily identified as follows:

Thread a spoke from outside through the hub flange of the hub cap side so that the spoke head finds its seat within the countersink of the spoke hole. This should be possible without requiring any noticeable force. Hold the hub so that the flanges are horizontal and the sprocket side faces upwards. The spoke should be facing radially outwards. The threaded end of the spoke should now find itself within the shaded area shown on the diagram below. Fig. b.

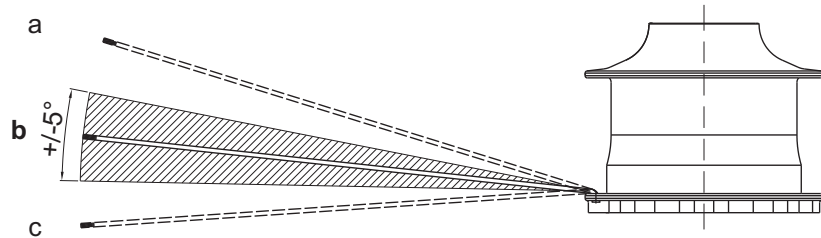

- a) Spoke bend is too short and/or the spoke bend diameter is too large.
- b) Spoke bend and spoke bend diameter are correct.
- c) Spoke bend is too long and/or the spoke bend diameter is too small.

Repeat this process. This time thread the spoke from the inside, outwards through the spoke flange on the sprocket side of the hub. Again, the spoke head should be seated within the countersink of the spoke hole and this without requiring a noticeable amount of force. Hold the hub so that the flanges are horizontal with the spoke facing radially outwards. The threaded end of the spoke should now find itself within the shaded area shown on the diagram below. Fig. e.

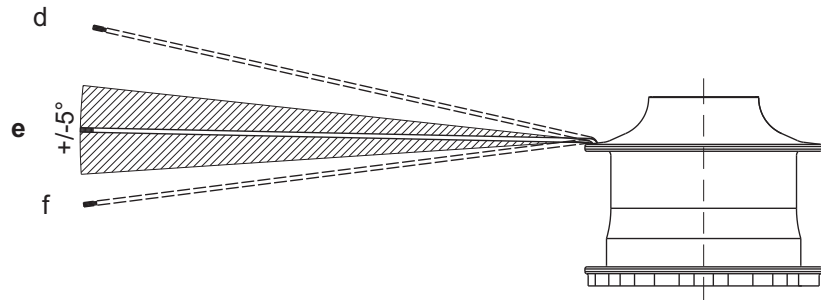

- d) Spoke bend is too short and/or the spoke bend diameter is too large.
- e) Spoke bend and spoke bend diameter are correct.
- f) Spoke bend is too long and/or the spoke bend diameter is too small.

Possible causes for flange breakages on bicycle hubs

Cause: Spoke bend length is too short and/or the spoke diameter at the bend is too large.

Effect: The spoke slightly deforms the flange as they are threaded and aligned into the hub shell or as the spokes are tensioned. This could lead to a flange breakage if this damage occurs at approximately 90° to the direction of the spoke tension. The source of the crack is the damage.

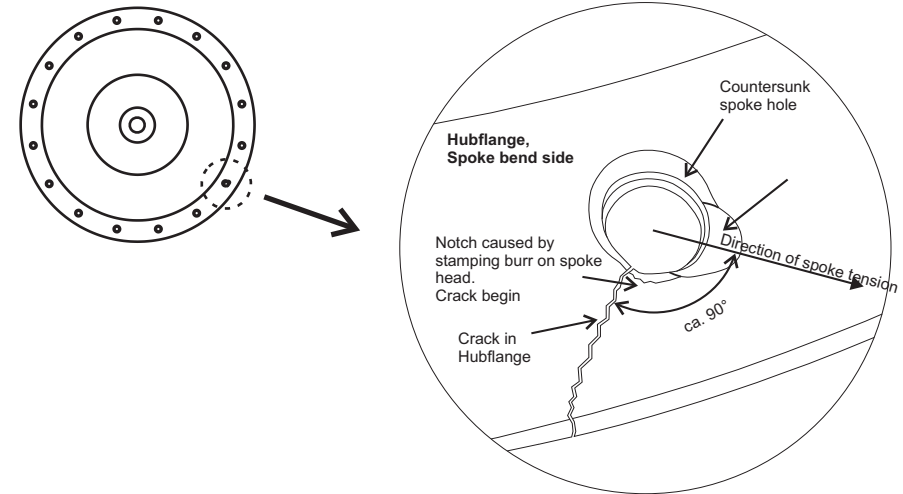

Cause: Stamping burr on the spoke head.

Effect: The burr on the spoke head stamps itself into the hub flange leaving a notch at the countersunk spoke hole. If this notch is to be found at an angle of approximately 90° to the direction of the spoke tension, then the flange could crack. The source of the crack is the burr on the spoke head.

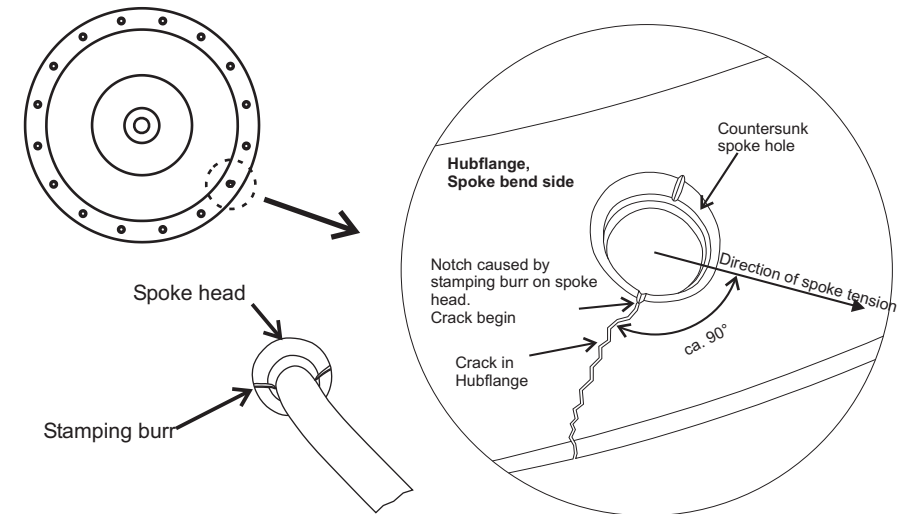

Possible causes for flange breakages on bicycle hubs

Cause: Loose spokes due to too long spoke bend length and/or too small diameter of the spoke at the bend. Spoke tension to low.

Effect: The spoke head of the unloaded spoke can move freely within the spoke hole of the hub flange, this in turn damages the inner surface of the spoke hole and leaves notches. The damage that can be found at approximately 90° to the direction of the spoke tension could lead to the hub flange cracking at this Point.

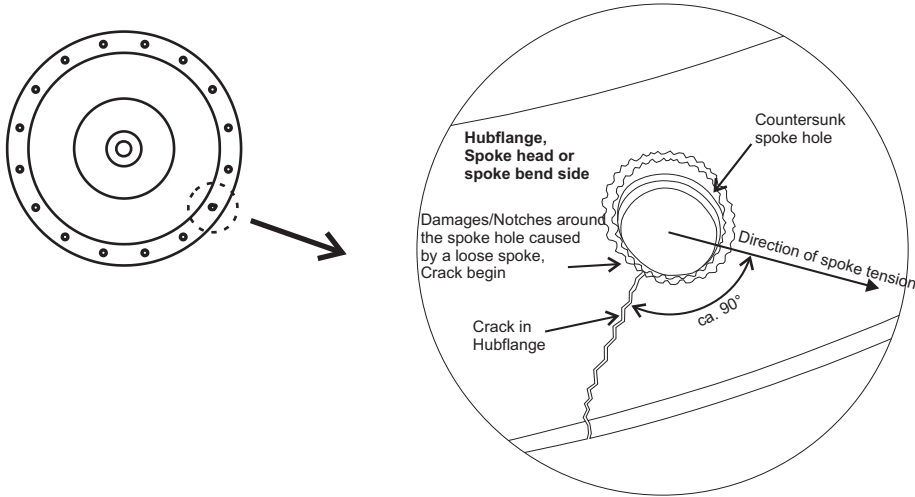

Cause: Re-lacing with alternative spoke alignment (second lacing of the hub).

Effect: The old embedment acts just like a notch or previous damage to the spoke hole. As this previous notch lies at an angle of approximately 90° to the new direction of the spoke tension, this could lead To the hub flange cracking at this point.

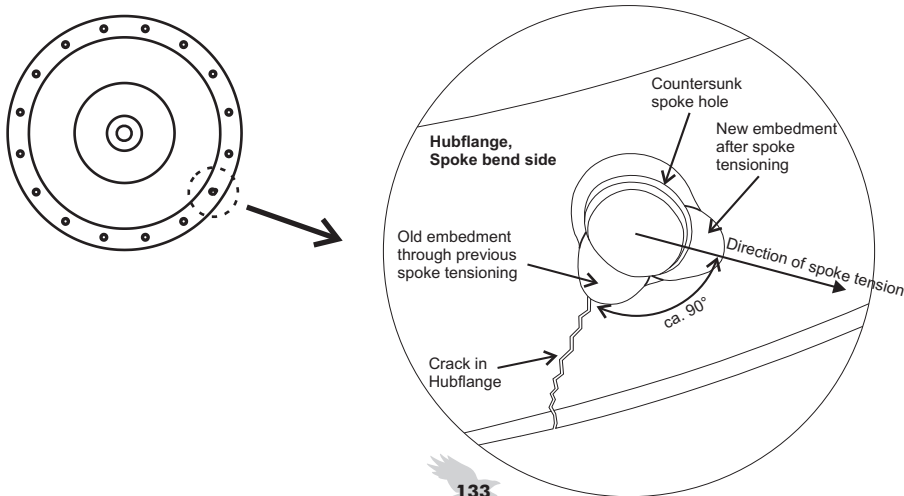

Flange Support Rings: Art.No. 8523 = 2x identical small rings
 Art.No. 8524 = 1x small ring, 1x large ring (groove - hub-cap side)

Fits all Rohloff SPEEDHUB 500/14 hubs. Mount to flange prior to lacing the wheel. Provides the flange with extra support in extreme/heavy duty (Tandem/Heavy duty touring, E-bike, Cargo, Cyclist 100kg) applications.
 Material: Anodized Black aluminum (20g).

Distinctive features

In der laufenden Serie wurden die Nabenflansche der SPEEDHUB verändert, so daß zwischen zwei unterschiedlichen Ausführungen unterschieden werden muß. Als Unterscheidungsmerkmal, welche Flanschrिंगe benutzt werden müssen, dient der Schriftzug 'Made in Germany' auf dem Gehäuse der SPEEDHUB.

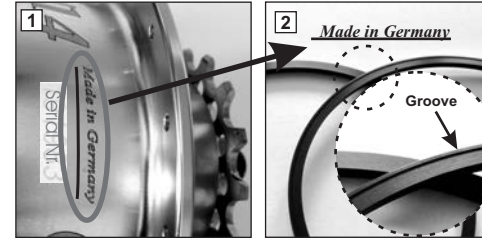

Art.No. 8524:
 = 1x small ring, 1x large ring (groove - hub-cap side)



Labeling underlined

Naben mit SerienNr. nach den genannten, haben nur auf der Deckelseite (links) einen erhöhten Flansch, so daß diese Naben zwei unterschiedliche Flanschrिंगe benötigen = Art.Nr. 8524

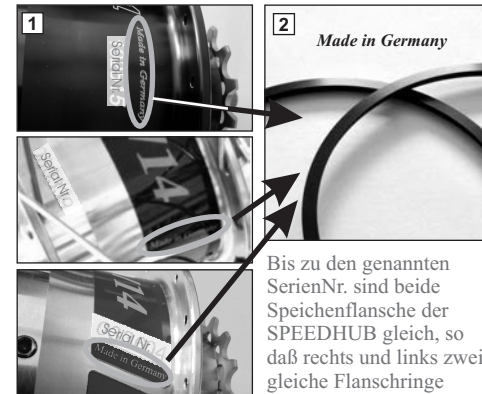
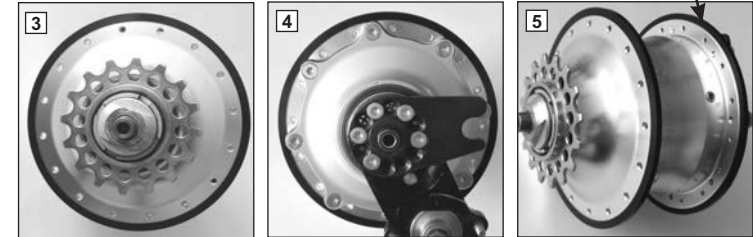

Art.No. 8523:
 = (2x identical small rings)



Labeling not underlined

Bis/upto Sr.Nr./Serial# = Art.Nr. 8523

- <196922 si/silver - 32-Loch/hole
- <198454 si/silver - 36-Loch/hole
- <196521 sw/black - 36-Loch/hole
- <196713 sw/black - 32-Loch/hole
- <197520 rot/red - 32-Loch/hole
- <197980 rot/red - 36-Loch/hole

TIP



Red powder coated hubshells are not compatible with the support rings!

Refer to Owners Manual for correct lacing ->Chapter Mounting -> The Wheel.
 Wheel stability & spoke lengths:- Chapter -> General Info -> The Wheel.

Twist Shifter 'light' - Right-Hand (Art. #8206)

Mounting the Twist Shifter

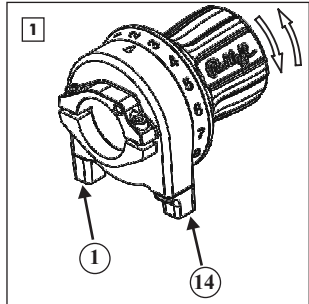

The Twist Shifter works with two shifter cables. When the Twist Shifter is rotated forward (direction of gear #14), then then the rear shifter cable #14 is pulled. When the Twist Shifter is rotated backwards (direction of gear #1), then then the rear shifter cable #1 is pulled.

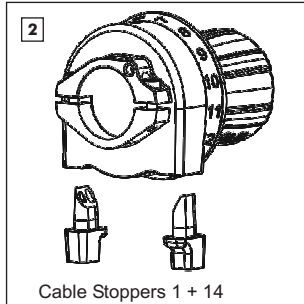

The Cable Stoppers for both shifter cables are identical and are simply inserted into the shifter housing facing in opposing directions. The Cable Stoppers can only be fully inserted if fitted correctly. An incorrect mounting is therefore impossible.

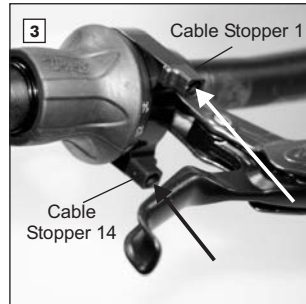

Slide the Twist Shifter over the right-hand handlebar end (handlebar diameter 22 - 22.3mm / 7/8"). Rotate the Twist Shifter so that the Cable Stoppers are evenly distanced above and below the brake lever.

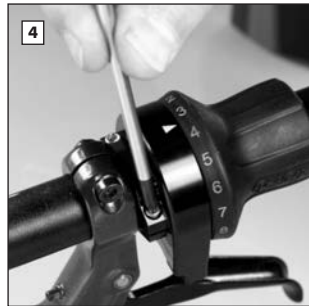

Both Clamp Screws (M3x12 - Torx TX20) should be lightly fitted so that the gap between both clamp elements is identical.

Insert the screws using the pressure of just two fingers on the TX20 tool. Finally tighten each screw by max. 2Nm (1/2 rotation). The Twist Shifter should now be tightly secured to the handlebars.

ATTENTION **Over tightening of the Clamp Screws can cause damage to both Twist Shifter and/or handlebars.**

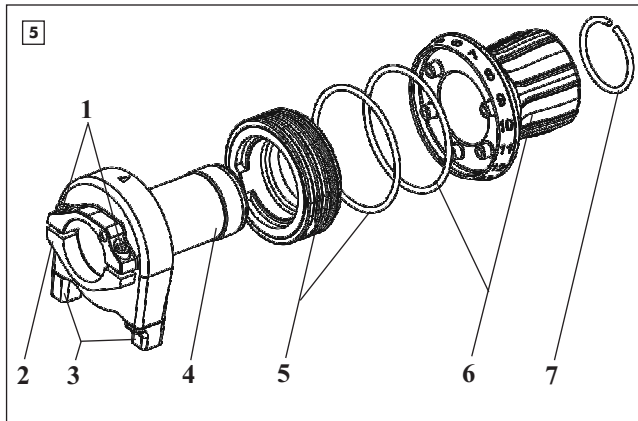

- 1 = Clamp Screws (Art. #8192)
- 2 = Clamp with Clamp Screws (Art. #8193)
- 3 = Cable Stoppers (Art. #8191)
- 4 = Shifter Housing (Art. #SA 01)
- 5 = Cable Pulley with O-Ring/Rubber Seal (Art. #8194)
- 6 = Rubber Grip with O-Ring/Rubber Seal (Art. #8190)
- 7 = Circlip (Art. #SA 18-N)

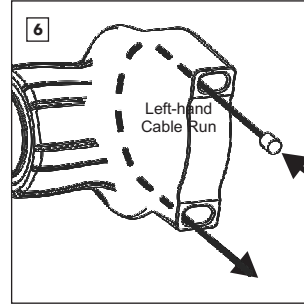

Fitment of Shifter Cable 14: Remove both Cable Stoppers from the Shifter Housing. Insert **Shifter Cable 14** into the Cable Pulley as illustrated above, until the cable end exits the Shifter Housing.



Rotate the Grip Rubber so that the gear indicator arrow falls **between gears #8 and #9**. Hold the Shifter in this position. **Pull Shifter Cable 14** completely into the Shifter Housing until the Nipple is seated correctly in the Cable Pulley.

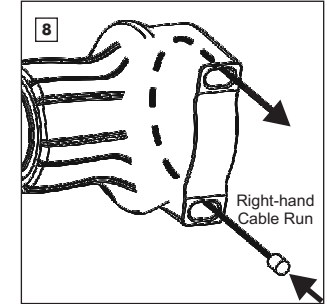

Insert **Shifter Cable 1** into the Cable Pulley as illustrated above, until the cable end exits the Shifter Housing.



Rotate the Grip Rubber so that the gear indicator arrow falls **between gears #6 and #7**. Hold the Shifter in this position. **Pull Shifter Cable 1** completely into the Shifter Housing until the Nipple is seated correctly in the Cable Pulley.

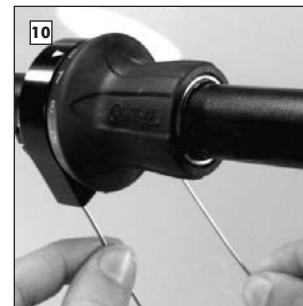

Check that the Shifter Cables run smoothly by pulling on each cable end alternatively. The Grip Rubber should rotate freely between both bed-stops slightly beyond gears #1 and #14.

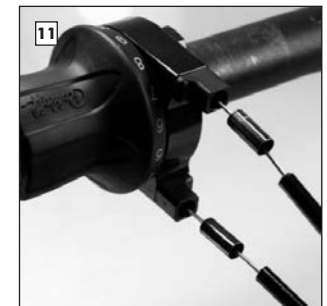

Mounting of Cable Housings with integrated liners: Thread the Cable Stoppers back over each Shifter Cable and push these firmly into the Shifter Housing facing in the correct position. Make sure to fit Ferrules between Cable Housing and Cable Stoppers.

ATTENTION **Pushing the Cables without the Cable Stoppers fitted could result in the Nipple becoming clamped on one of the Shifter Cable exits or within the Shifter Housing itself.**

Rubber Grip replacement - Right-hand (Art. #8190)



Replacement:
When replacing the Grip Rubber, it is not necessary to remove or replace the shifter cables.

Using a small, flat screwdriver prise the Circlip out of position and remove from the Shifter Housing.

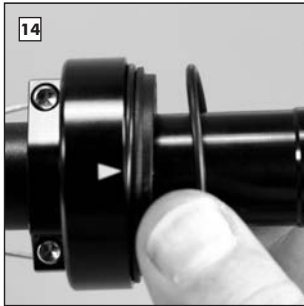

Before fitting the replacement Grip Rubber, check that the O-ring is seated correctly on the Cable Pulley.

ATTENTION

Remove Shifter from Carbon Fiber Handlebars to avoid potential damage when removing the Circlip.

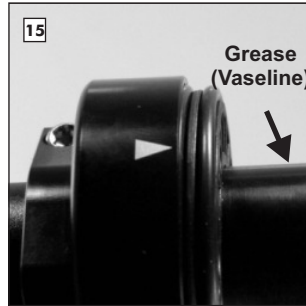

TIP

Lightly grease the inside of the Cable Pulley to ensure easy operation.

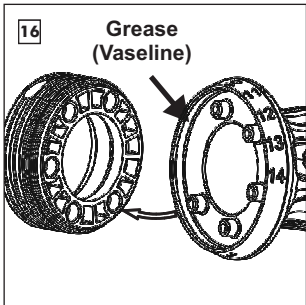

The Grip Rubber and the Cable Pulley will only marry in one position. The Cable Pulley has 5 blind holes which correlate with the 5 pins found on the Grip Rubber. It is therefore impossible to re-mount the Grip Rubber incorrectly.

Lightly grease the inside of the Grip Rubber prior to mounting back over the Shifter Housing.

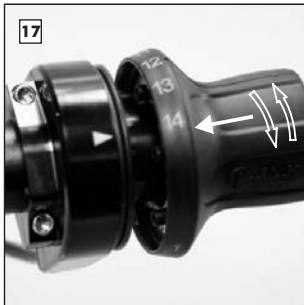

When connecting both components, slide the Grip Rubber fully over the Shifter Housing and lightly rotate until it falls into position in the Cable Pulley.

TIP

Push the Rubber Grip lightly into the final position over the O-ring until it reaches the bedstop.

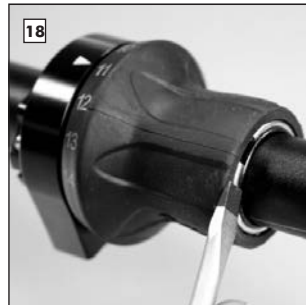

Replace the Circlip back onto the Shifter Housing. Check that the Shifter rotates freely.

Removing Shifter Cables for Replacement (Repair) Right-Hand Twist-Shifter

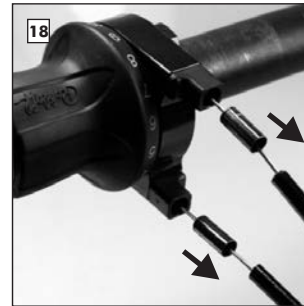

Remove both Shifter Cables housings and corresponding Ferrules from the Shifter Housing.



Rotate the Shifter (with fitted Cable Stoppers) until the gear indicator on the Shifter Housing is positioned **between numbers 8 and 9**. Hold the Shifter in this Position.

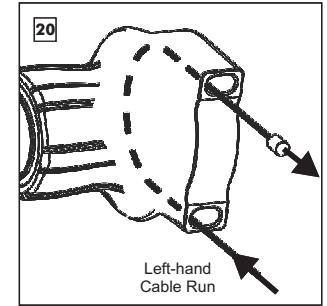

Remove both Cable Stoppers. **Push Shifter Cable 14** out of the Shifter Housing until the Nipple is free. Pull the Cable Nipple to completely remove the Shifter Cable.

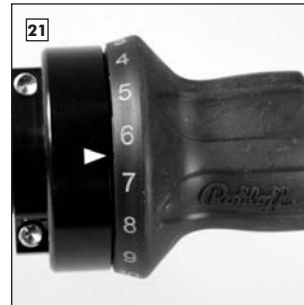

Rotate the Shifter (with fitted Cable Stoppers) until the gear indicator on the Shifter Housing is now positioned **between numbers 6 and 7**. Hold the Shifter in this Position.

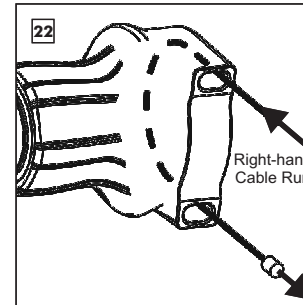

Remove both Cable Stoppers. **Push Shifter Cable 1** out of the Shifter Housing until the Nipple is free. Pull the Cable Nipple to completely remove the Shifter Cable.

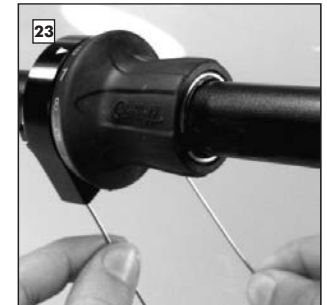

Refit the Shifter Cables into the Twist Shifter as described in the mounting instructions - Fig. 6 - 11.

ATTENTION

Pushing the Cables without the Cable Stoppers fitted could result in the Nipple becoming clamped on one of the Shifter Cable exits or within the Shifter Housing itself.

Twist Shifter 'light' - Left-hand (Art. #8207)

Left-hand Twist Shifter Mounting

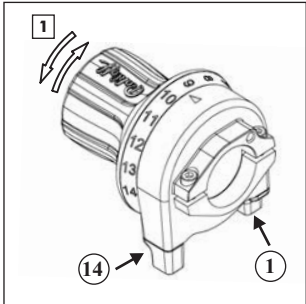

The Twist Shifter works with two shifter cables. When the Twist Shifter is rotated forward (direction of gear #14), then then the rear shifter cable #14 is pulled. When the Twist Shifter is rotated backwards (direction of gear #1), then then the rear shifter cable #1 is pulled.

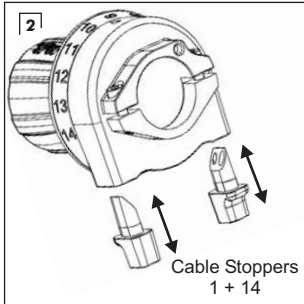

The Cable Stoppers for both shifter cables are identical and are simply inserted into the shifter housing facing in opposing directions. The Cable Stoppers can only be fully inserted if fitted correctly. An incorrect mounting is therefore impossible.

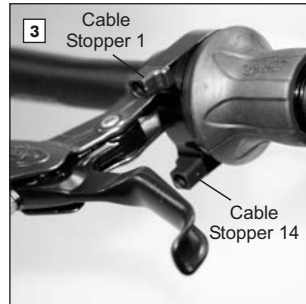

Slide the Twist Shifter over the left-hand handlebar end (handlebar diameter 22 - 22.3mm / 7/8"). Rotate the Twist Shifter so that the Cable Stoppers are evenly distanced above and below the



Both Clamp Screws (M3x12 - Torx TX20) should be lightly fitted so that the gap between both clamp elements is identical.

Insert the screws using the pressure of just two fingers on the TX20 tool. Finally tighten each screw by max. 1/2 rotation. The Twist Shifter should now be tightly secured to the handlebars.

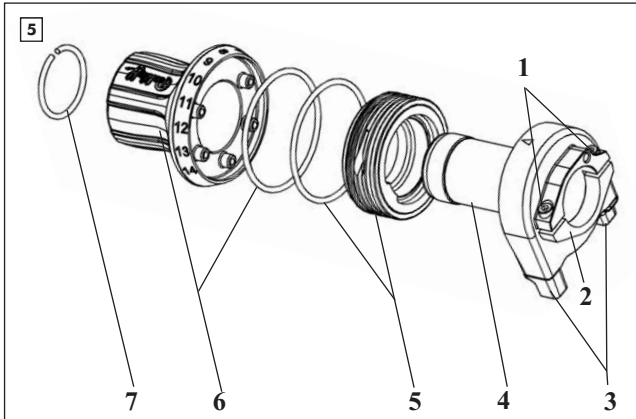

- 1 = Clamp Screws (Art. #8192)
- 2 = Clamp with Clamp Screws (Art. #8193)
- 3 = Cable Stoppers (Art. #8191)
- 4 = Shifter Housing (Art. #SA 01)
- 5 = Cable Pulley with O-Ring/Rubber Seal (Art. #8194)
- 6 = Rubber Grip with O-Ring/Rubber Seal (Art. #8195)
- 7 = Circlip (Art. #SA 18-N)

ATTENTION !

Over tightening of the Clamp Screws can cause damage to both Twist Shifter and/or handlebars.

Fitment of Shifter Cables

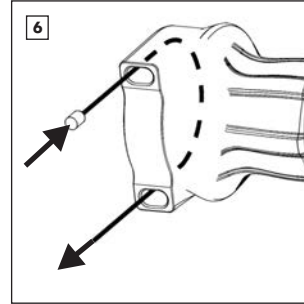

Fitment of Shifter Cable 14: Remove both Cable Stoppers from the Shifter Housing. Insert **Shifter Cable 14** into the Cable Pulley as illustrated above, until the cable end exits the Shifter Housing.

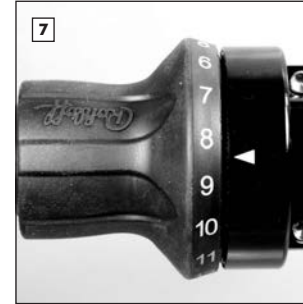

Rotate the Grip Rubber so that the gear indicator arrow falls **between gears #8 and #9**. Hold the Shifter in this position. **Pull Shifter Cable 14** completely into the Shifter Housing until the Nipple is seated correctly in the Cable Pulley.

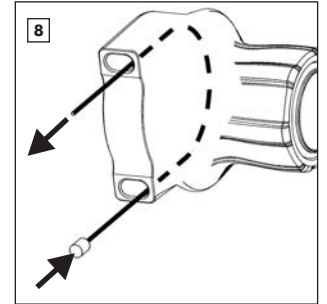

Insert **Shifter Cable 1** into the Cable Pulley as illustrated above, until the cable end exits the Shifter Housing.



Rotate the Grip Rubber so that the gear indicator arrow falls **between gears #6 and #7**. Hold the Shifter in this position. **Pull Shifter Cable 1** completely into the Shifter Housing until the Nipple is seated correctly in the Cable Pulley.



Check that the Shifter Cables run smoothly by pulling on each cable end alternatively. The Grip Rubber should rotate freely between both bed-stops slightly beyond gears #1 and #14.

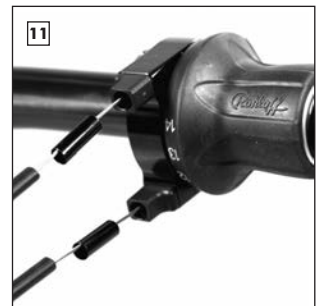

Mounting of Cable Housings with integrated liners: Thread the Cable Stoppers back over each Shifter Cable and push these firmly into the Shifter Housing facing in the correct position. Make sure to fit Ferrules between Cable Housing and Cable Stoppers.

ATTENTION !

Pushing the Cables without the Cable Stoppers fitted could result in the Nipple becoming clamped on one of the Shifter Cable exits or within the Shifter Housing itself.

Rubber Grip replacement - Left-hand (Art. #8195)

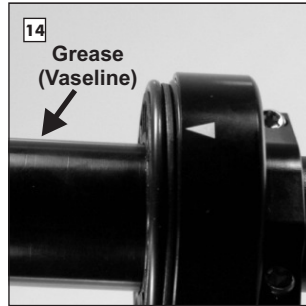
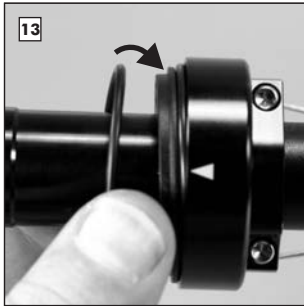
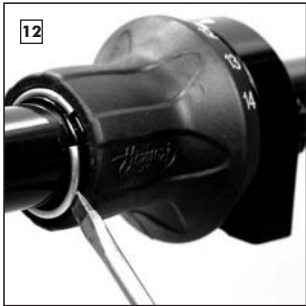

Replacement:
When replacing the Grip Rubber, it is not necessary to remove or replace the shifter cables.

Before fitting the replacement Grip Rubber, check that the O-ring is seated correctly on the Cable Pulley.

Using a small, flat screwdriver prise the Circlip out of position and remove from the Shifter Housing.

TIP
Lightly grease the inside of the Cable Pulley to ensure easy operation.

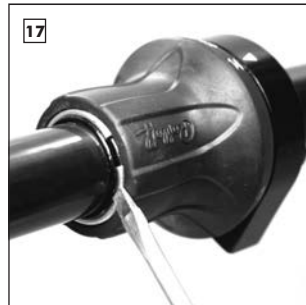
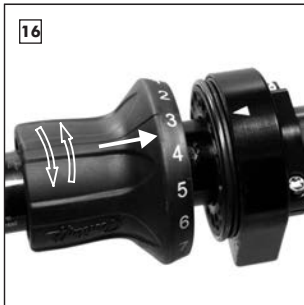
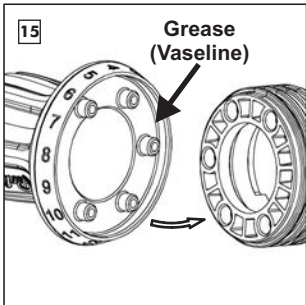

The Grip Rubber and the Cable Pulley will only marry in one position. The Cable Pulley has 5 blind holes which correlate with the 5 pins found on the Grip Rubber. It is therefore impossible to re-mount the Grip Rubber incorrectly.

When connecting both components, slide the Grip Rubber fully over the Shifter Housing and lightly rotate until it falls into position in the Cable Pulley.

Replace the Circlip back onto the Shifter Housing. Check that the Shifter rotates freely.

TIP
Push the Rubber Grip lightly into the final position over the O-ring until it reaches the bedstop.

Removing Shifter Cables for Replacement (Repair) - Left-Hand Twist Shifter

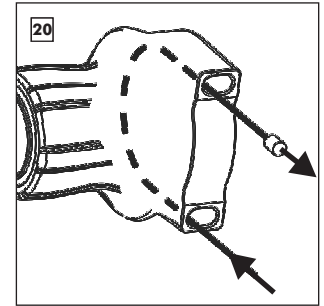
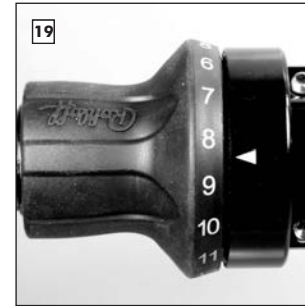
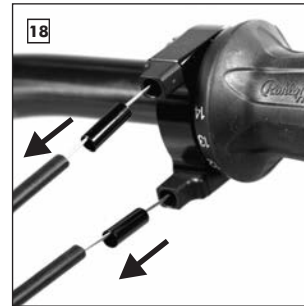

Remove both Shifter Cables housings and corresponding Ferrules from the Shifter Housing.

Rotate the Shifter (with fitted Cable Stoppers) until the gear indicator on the Shifter Housing is positioned **between numbers 8 and 9**. Hold the Shifter in this Position.

Remove both Cable Stoppers. **Push Shifter Cable 14** out of the Shifter Housing until the Nipple is free. Pull the Cable Nipple to completely remove the Shifter Cable.

Mounting Shifter Cables:

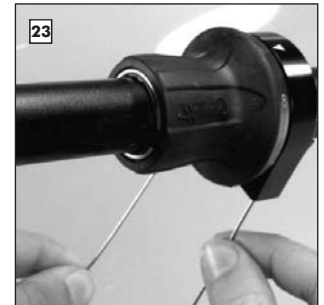
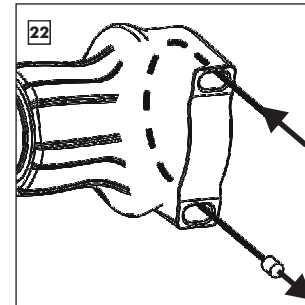
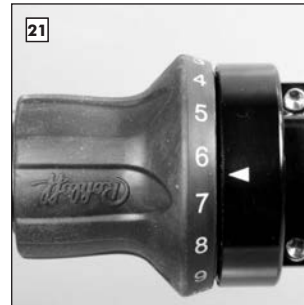

Rotate the Shifter (with fitted Cable Stoppers) until the gear indicator on the Shifter Housing is now positioned **between numbers 6 and 7**. Hold the Shifter in this Position.

Remove both Cable Stoppers. **Push Shifter Cable 1** out of the Shifter Housing until the Nipple is free. Pull the Cable Nipple to completely remove the Shifter Cable.

Refit the Shifter Cables into the Twist Shifter as described in the mounting instructions - Fig 6 to 11.

ATTENTION
Pushing the Cables without the Cable Stoppers fitted could result in the Nipple getting clamped on one of the Shifter Cable exits or within the Shifter Housing itself.

Splined Sprocket Carrier (Art.#8540) + small (Art.#8540s)

Every Rohloff SPEEDHUB 500/14 unit can be upgraded to use this new splined sprocket system. All splined sprockets are reversible - **always fit a new chain when reversing the sprocket!** The 54mm chain-line of older 15/16/17 tooth sprockets will be moved with **Carrier #8540** out to **57mm** (position of outermost chainring on modern triple cranksets).

The **belt-line** with carrier #8540 of a Carbon Drive transmission remains **55mm (+/-1mm)** as before.

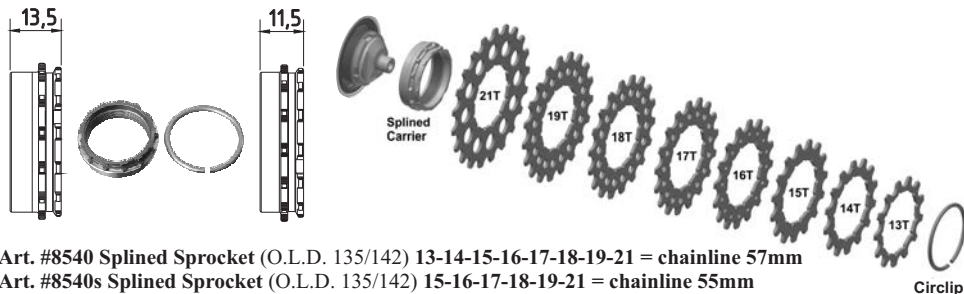

Art. #8540 Splined Sprocket (O.L.D. 135/142) 13-14-15-16-17-18-19-21 = chainline 57mm
 Art. #8540s Splined Sprocket (O.L.D. 135/142) 15-16-17-18-19-21 = chainline 55mm

Initial mounting - Splined Carrier:

Preparation:

Slide the reversible splined sprocket fully over the clean carrier so that it lies against the polished seal rub-ring. Snap the circlip over the carrier by hand ensuring this sits correctly in the carrier seat.

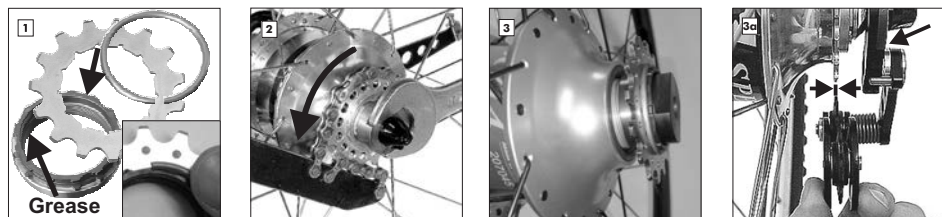

Check the sprocket is tight. Lightly grease the threads of the splined carrier.

Clean the around the sprocket and ensure the driver pockets are free from dirt. Unscrew sprocket in a counter-clockwise direction using a chain-whip and secured sprocket remover tool.

Clean any foreign particles from the seal lip and driver with a clean cloth. Slide the pre-assembled sprocket/carrier unit carefully over the remover tool (as a locating guide) and then fully down onto the driver.

Use the distancing washers provided (arrowed) to ensure the upper jockey-wheel teeth are directly under the teeth of the sprocket. Use of a longer mounting bolt (Art. #8255) & distancing washers (Art. #8526) may be necessary.

POINTER

135/142mm O.L.D. SPEEDHUB with splined sprocket:

13-21 tooth = 57mm chain-line (Carrier 8540)

15-21 tooth = 55mm chain-line (Carrier 8540s)

170/177/190/197mm O.L.D. SPEEDHUB with splined sprocket:

13-21 tooth = 75mm chain-line (Carrier 8540)

15-21 tooth = 73mm chain-line (Carrier 8540s)

Splined Carrier #8540 with Splined Gates Carbon Drive sprocket:

135/142mm O.L.D. = 55mm (+/-1mm) belt-line.

170/177/190/197mm O.L.D. = 73mm (+/-1mm) belt-line.

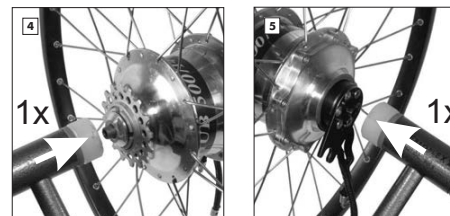

Check the smooth/light motion of the sprocket by rotating this backwards. If you notice excessive resistance, then the free-floating (sprocket side) bearing may rest under tension and will need to be loosened. Do this by thumping each axle stub with a plastic mallet (sprocket side once, then gear-mech side once). Sprocket must now rotate backwards smoothly with little resistance.

POINTER

Gear inches:

The increased number of sprocket sizes now offers a wider choice of chainring/sprocket combinations. The updated gear inch tables are all available online under the link below. Please consult these tables to calculate the desired ratio and then to check this is authorized for SPEEDHUB use. Experience shows a factor of 2.5 - 2.8 is ideal for touring/commuter use (factor = # chainring teeth ÷ # sprocket teeth).

Gear inch tables:

www.rohloff.de/en/technology/workshop/gear_meters_table/index.html



POINTER

Please refer to the instructions in your owners manual or the videos on our Youtube channel for:
 -Sprocket replacement
 -Mounting the chain tensioner
 -Special applications



Art. 8501 (135/170) Art. 8508 (135/142/170/177) Art. 8509 (148/190/197)

The sprocket remover tool #8508 (with adapter and bolt) must be used for all 142/177mm O.L.D. SPEEDHUB units.

The original sprocket remover tool (Art. #8501) can only be used with 135/170mm O.L.D. SPEEDHUB units.

Sprocket remover tool Art. #8509 must be used (with an A12 adapter and bolt) for all 148/190/197mm O.L.D. XXLSPEEDHUB units.

ATTENTION

Special applications:

The splined sprockets and rotating SPEEDHUB must not under any circumstances collide or rub against other components mounted to the bicycle. Failure to avoid such component collisions will result in additional noise and component damage!

1. Use of a Hebie Chainglider:

The rear portion of a Hebie Chainglider Type 350 is not compatible with the SPEEDHUB splined sprocket system. Hebie are currently (at time of press) working on an alternative solution - see FAQs at www.rohloff.de/en/

2. Use of an enclosed chain-case:

The revised chainline can lead to collisions between the chain-case and bicycle frame. Please consult the bicycle manufacturer directly for advice.

3. Use of a chain tensioner:

The revised chainline may require the use of a longer mounting bolt (Art. #8255) & distancing washers (Art. #8256).

Should the frame O.L.D. 148/190/197mm or utilize a Shimano direct-mount derailleur hanger, then a 'Chain Tensioner -10' (Art.#8520-10) will be required

4. Use with specialist frames:

The 3mm wider revised chainline may lead to collisions between larger splined sprockets or the chain itself with the dropout or seatstay tubing.

Please use the template provided to check for possible collision areas.

Monkey Bone IS-PM Adapter for O.L.D. 135/142/148/170/177mm (160mm = Art. #8553) (180mm = Art. #8554)

Monkey Bone IS-PM Adapter for Fatbike O.L.D. 190/197mm (160mm = Art. #8553-10) (180mm = Art. #8554-10)

The Monkey Bone rear disc IS-PM brake adapter offers a simple method of anchoring the axle of the Rohloff SPEEDHUB 500/14 to a frame through the disc brake mount. In order to use the Monkey Bone, your SPEEDHUB 500/14 will need an OEM2 axleplate, your frame must have an International Standard disc brake interface, and your disc brake caliper must have a Postmount interface. The Monkey Bone is not compatible with IS direct-mount disc brake calipers or frames with Postmount disc brake interface.

Installation Instructions

1. Ensure that you have the Monkey Bone that is appropriate for your disc rotor diameter (160mm or 180mm; 203mm rotors can be used with 180mm Monkey Bone and spacers (sold separately)).
2. Attach the Monkey Bone to the frame using two M6x18-20 bolts. Ensure that slot for OEM2 axleplate faces the dropout. Tighten bolts to a torque of 6Nm/51 in-lbs.
3. Connect disc brake caliper to Monkey Bone using two M6x16 bolts (for Fatbike M6 x 30mm). Leave bolts loose enough that caliper can slide side to side.
4. Install wheel into dropout taking care to align slot in end of OEM2 axleplate with cutout in Monkey Bone and disc rotor between brake pads.
5. Check position of EX shift arm with OEM2 axleplate engaged with slot in Monkey Bone; reposition axleplate as needed for desired cable routing using T20 Torx wrench (see Rohloff Owners Manual). Tighten axleplate screws to a torque of 3Nm/25 in-lbs.
6. Fully seat axle in dropout before tightening quick-release lever or axle nuts. Threaded axle nut torque: 30 Nm/310 in-lbs; Pitlock or bolt-on skewer torque: 7 Nm/60 in-lbs.
7. Follow brake manufacturer's recommendation for setting brake caliper position. Tighten brake caliper bolts to a torque of 6Nm/51 in-lbs.

Identifying Features:

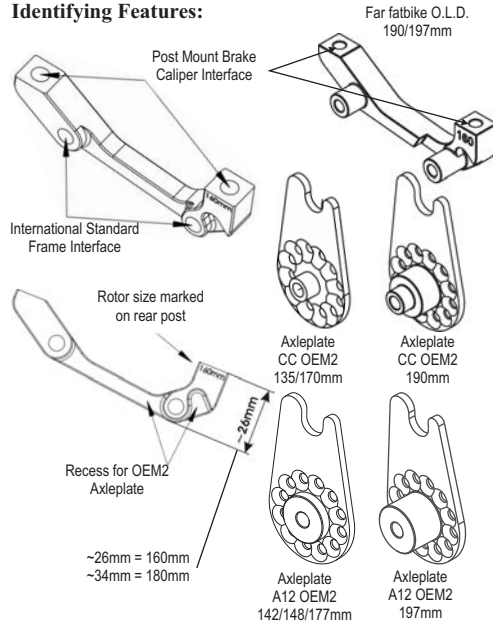

Required Tools:

- 5mm Allen wrench
- Torque wrench
- T20 Torx wrench

Required Parts:

- Frame with IS51 disc caliper mount interface
- Disc brake caliper with Postmount interface
- Rohloff SPEEDHUB 500/15 with OEM2 axleplate
- Monkey Bone/Monkey Bone-10
- 2x M6x16 bolts (sold separately; typically included with disc brake caliper)
- 2x M6x18-20 bolts (sold separately; typically included with disc brake caliper)
- Identifying Features
- 2x M6 x 30mm bolts (included with Art. #8553-10 and Art. #8554-10)

Assembly Views 135/142/148/170/170/190/197mm

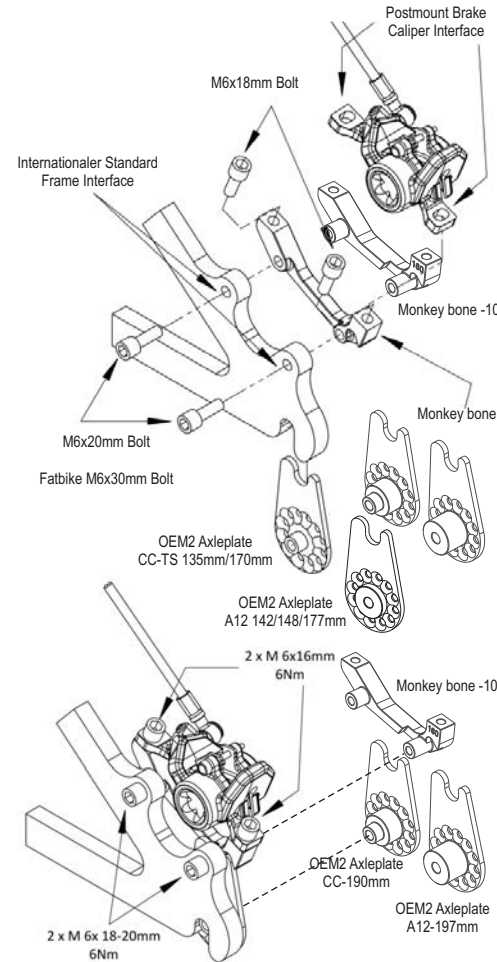

Permissible with CC/TS axle:

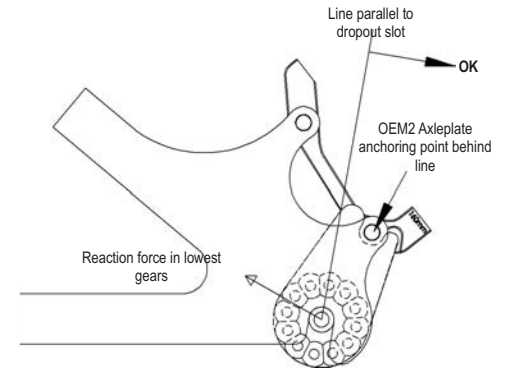

Non permissible with CC/TS axle

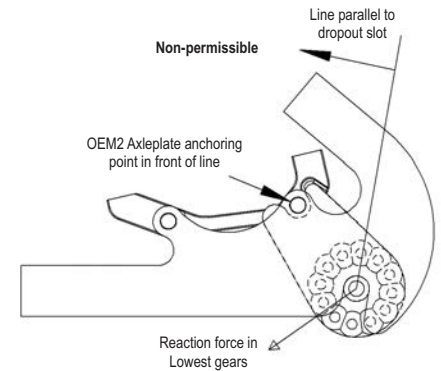

ATTENTION

Use of the Monkey Bone (both CC & TS Axles) with certain frames could result in the wheel being levered out of the dropout while pedaling due to the forces exerted by the Rohloff SPEEDHUB 500/14 onto the frame. The reaction force in the lowest gears can lever the axle down and out of the dropout slot if the anchoring point of the OEM2 axleplate is located in front of a parallel line through the dropout slot. The Monkey Bone and OEM2 axleplate combination is not permissible for use on such frames.

Use of the Monkey Bone and OEM2 axle plate is entirely at the user's own risk. The forces applied to the disc brake mount by the Rohloff SPEEDHUB 500/14 can damage some frames. Please contact your frame manufacturer to determine whether this setup is appropriate for your frame and whether it affects your frame warranty.

PM Bone (Art.#8555) PM axleplate (CC PM =Art.#8225), A12 PM (Art.#8558)

The Rohloff PM Axleplate in combination with the PM Bone offers an alternative method of anchoring the hub torque to frames with a 135mm, 142mm, 170mm or 177mm spacing. The PM Axleplate/PM Bone combination is recommended when mounting a SPEEDHUB in all frames with an integrated Postmount direct calliper mount. The threaded holes of the direct calliper mount will be used to secure the PM Bone.

Three different mounting options are available:

1. Mounting to frames where the (PM) direct brake caliper mount is on the seat-stay.
2. Mounting to frames where the (PM) direct brake caliper mount is on the chain-stay.
3. Mounting on frames where an International Standard (IS) brake caliper mount is on the Chainstay.

ATTENTION

The PM Bone (Art.#8555) must be mounted directly under the disc brake calliper. This acts as an adapter and thus its use will require the larger brake rotor:

PMdirect 140mm = Not compatible!

PM direct 160mm = 180mm rotor required!
PM direct 180mm = 203mm rotor required!

PM direct 203mm = Not compatible!

PM Bone - Mounting preconditions:

The axle area of the Rohloff PM Axleplate must lie flush against the dropout material.

The axleplate may under no circumstances collide with weld-beads or proud standing frame tubes.

Safe use of the PM Bone/PM axleplate is only possible if these two preconditions are satisfied.

ATTENTION

The various different standards & production tolerances of the Postmount caliper mount will result in the PM Bone locating peg resting at different heights within the PM axleplate fork.

-Frames using a 160mm direct postmount must result in a gap of min. 0.3mm between the plate & bone (use spacers if necessary).

-Frames using a 180mm direct postmount must result in a gap of max. 7mm between the plate and bone.

Get in touch with Rohloff service should issues arise when mounting the two PM components.

ATTENTION

Neither the PM Bone nor PM axleplate are authorized or tested for tandem use!

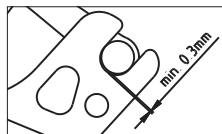
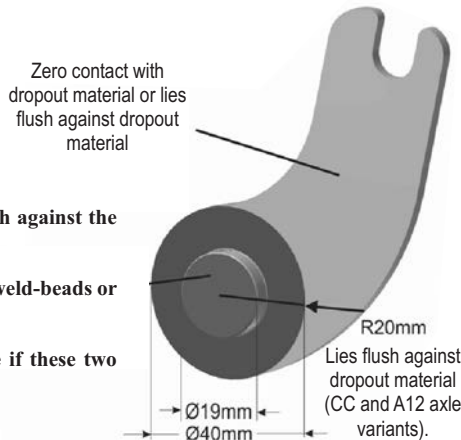
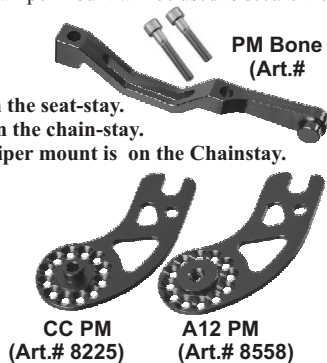

160mm direct mount

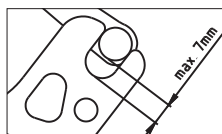

180mm direct mount

1. Mounting to frames where the PM direct brake caliper is located on the seat-stay.

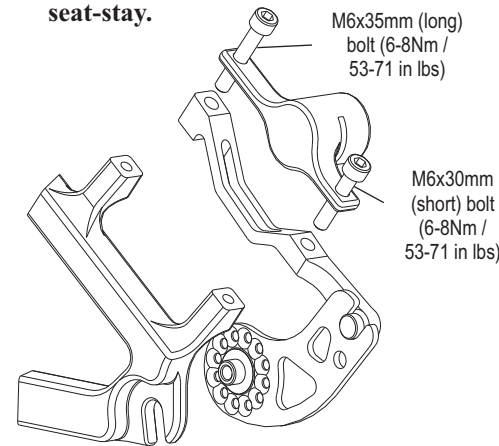

ATTENTION

Use of the PM Bone/PM axleplate is only permitted in dropouts where the PM Bone anchoring point falls behind an imaginary line drawn through the dropout slot itself. The correct location of the anchoring point is vital to ensure the axle cannot lever itself out of the dropout and thus to avoid potential accidents and injuries!

3. Mounting on frames with an IS brake caliper mount located on the Chainstay.

An IS/PM adapter is secured to the IS calliper mount as usual. The Rohloff PM Bone (Art.#8555) is then mounted to this and the calliper then bolted to the IS/PM adapter through the PM Bone.

POINTER

Possible combinations:

IS frame 160mm + IS/PM Adapter 160mm + PM Bone = 180mm rotor required.

IS frame 180mm + IS/PM Adapter 180mm + PM Bone = 203mm rotor required.

2. Mounting to frames where the PM direct brake caliper is located on the chain-stay.

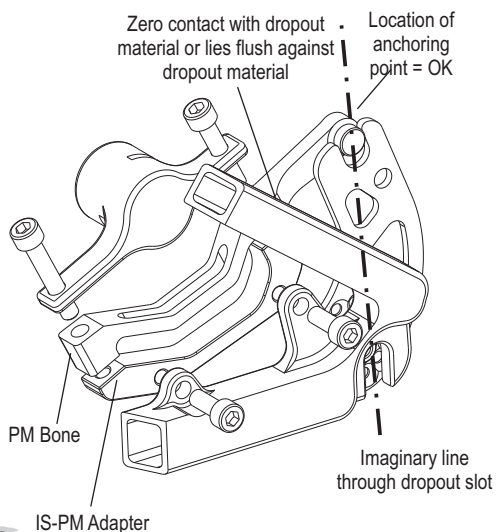
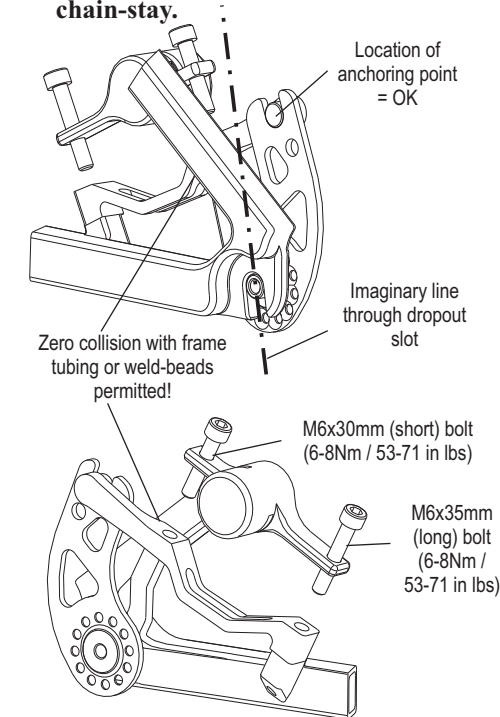

This Owners Manual is also available in a variety of other languages. Should you require a different version, you can download it from our homepage under:

www.rohloff.de > Service > Download > Documentation

The following languages are available:

- English**
- German**
- French**
- Dutch**
- Italian**
- Russian**



TIP



- Owners Manual - Newest version
- Films

The newest version of this Manual is available on the web under:
www.rohloff.de > service > downloads > documentation > owners manual

Further to the manual, the most important work, service and repairs on the SPEEDHUB 500/14 are shown in short films on the web.
www.rohloff.de > Technology > Workshop > Videos ...

Keyword	Page
A Advantages of the options	38
Axle plate alignment	64
Axle plates	46
Axle ring - One-piece / Quick-change	98, 104
Axle types	24
Adapter IS-PM (Monkey Bone)	28/40/46/48/53
B Beltdrive System (Gates Carbon Drive)	3, 48
Bolt/tool info	124
Brake disc - replacement	60, 91
Brake discs / rotors	37
Break-in period	6
C Cable routing via the brake boss - Internal gear mech	76
Cable routing via the chainstay - External gear mech	80
Cable routing via the chainstay - Internal gear mech	79
Cable routing via the top tube - External gear mech	83
Carbon handlebars	48
Chain guide - DH (accessory for downhill)	45, 58
Chain guide - CC	71
Chain tensioner - DH (accessory for downhill)	45, 68, 69
Chain tensioner - mounting	70
Chain tensioner spring - changing	109
Chainguard enclosed	48
Chainring - two chainrings	45, 47
Cleaning the Rohloff SPEEDHUB 500/14	7
Colors	33
Comparison - Derailleur gears and Rohloff SPEEDHUB 500/14	21
Comparison to derailleur gears	22
Components that we recommend	45
Cranksets, Crankset	45, 57
D Distance travelled per crank revolution (20", 26" and 28")	20
E Eccentric BB	48
Effective Rim Diameter - calculating	44
Emergency repairs	10
External gear mech - grub screw	129
External gear mech - mounting	32, 93
External gear mech - OEM / OEM2 / long torque arm	63
F Flange breakages on bicycle hubs - possible causes	132
Flange Support Rings	142
Failure Diagnosis	119
Filling with oil	84
Frame mounted gear box	47
Frame types - OEM / OEM2 / long torque arm	27-29
G Gates Carbon Drive	3, 48
Gear display	83
Gear mech - replacement	92
Gear unit - installation - removal	111, 112
Grub screw of the External gear mech	129
Guarantee information	1, 128
H Hub cable - replacement	97
Hub seal - replacement	114
I Internal gear mech	31
Internal gear mech - via brake boss / via chainstay	61, 62
L Long torque arm	56
M Maintenance and care	7, 8, 89
Mechanical efficiency - comparison	18
Model codes - explanation	33
Model variations	39
Modular system	23
Monkey Bone IS- PM Adapter for OEM2 axleplate	28/40/46/48/53
Mounting (CC / TS versions) with a long torque arm	65, 66
Mounting necessities OEM2	30
Mounting processes	49

Key word	Page
N Noises	6
Notes	134-135
O OEM axle plate	67
OEM2-mounting with a support bolt-SPEEDBONE/MonkeyBone	59
OEM2 axle plate	67
Oil change	7, 87
One-piece axle ring - removal	92
Options	38
P Package contents - checking	51
Particular components	45, 46, 47
Pushing the bike	6
Q Quick-change axle ring - removal	92
R Racing bike / drop handlebars	46
Reference to Serial No.	128
Removal of the wheel from the frame	13
Replacing the gear unit	92
Reversing / Replacing of the sprocket	90
Riding noises	6
Rims	46
Rubber grip - replacement	110
S Safety information	3
Schlumpf Speed-drive, High Speed-drive	47
Securing to the frame	23-30
Serial No. - Pointers	128
Service procedures	96
Shifter - mounting	73
Shifter cables	75
Shifting gears	5
Small parts bag - checking the contents	53
Small wheels	47
Smallest permitted sprocket ratios	19
Special applications	47, 48
SPEEDBONE / Monkey Bone	46
Spoke length - calculating	42, 43
Spokes	46, 130
Sprocket ratios - smallest	19
Sprocket reversing/replacement	90
Sprockets	45
Stand - axle mounted	47
T Tandem use	47
Technical data	17, 127
Tools and Bolts / Tools for the tour	124, 9
Torque securing	25
Tour info	9
Trailer use	47
Transport - Info for the tour	9
Trouble shooting	119
Twist shifter - mounting	73
W Warranty information	1, 128
Wearable parts	6
Weight comparison	18
Wheel installation	14
Wheel lacing for rims with a European spoke hole pattern	125
Wheel lacing for rims with a French spoke hole pattern	126
Wheel removal (internal, external gear mech)	11
Wheel stability	41
Wheel lacing	55, 130