

OWNER'S MANUAL

pinion

DRIVE TECHNOLOGY

 ***P1.18*** ***P1.12*** ***P1.9^{XR}*** ***P1.9^{CR}***

© Pinion GmbH 2016

All rights reserved

Printed in Germany

06-2016

Inhalt:

www.technische-redaktion.de

INTRODUCTION

Foreword.....	4
Symbols.....	4

TECHNICAL DATA

Development.....	7
Tightening torques.....	7

SAFETY

Intended use.....	8
-------------------	---

Basic safety instructions	8
-------------------------------------	---

ON THE ROAD

Running in the transmission	10
Before every ride.....	10
Shifting correctly.....	11

INSTALLATION WORK

Installing rotary shifter ..	12
Installing or replacing pulling cables.....	13
Installing Pinion chain tensioner ..	22
Adjusting chain tension (Pinion chain tensioner)	23
Replacing chain ring.....	24
Installing cranks.....	25
Chain length & chain tension.....	26
Installing transmission ..	26
Removing transmission .	27

MAINTENANCE WORK

Frequency.....	28
Adjusting shifting.....	29
Oil change.....	30
Oil change data.....	31

LEGAL INFORMATION

Liability.....	32
----------------	----

INTRODUCTION

FOREWORD

You are now the owner of a modern Pinion bicycle transmission – made in Germany.

This owner's manual is a part of your Pinion product and contains information on how to operate, adjust, install and maintain your product safely.

Read this manual carefully before using your Pinion product. Always observe and follow all instructions in this manual – and also the user instructions from other manufacturers whose products are used on your bicycle (chain, wheels, quick release skewers etc.).

Remember that the mechanic is responsible for the suitability and compatibility of all components that interact with your Pinion product.

WARNING

If the instructions in this manual are not observed, this may result in accidents with fatal consequences or serious injury.

SYMBOLS

 The pointing finger prompts you to carry out an action.

 The arrow shows results or requirements.

 This instruction gives you additional information or tips.

P1.18 Instructions with this indication only relate to the corresponding type of your Pinion bicycle transmission.

WARNING

This instruction warns of a hazardous situation, which if not avoided may result in death or serious injury.

CAUTION

This instruction warns of a hazardous situation, which if not avoided may result in minor or moderate injury.

NOTICE

This instruction warns of potential material damage.

NOTICE – ENVIRONMENT

This instruction warns of potential environmental damage.

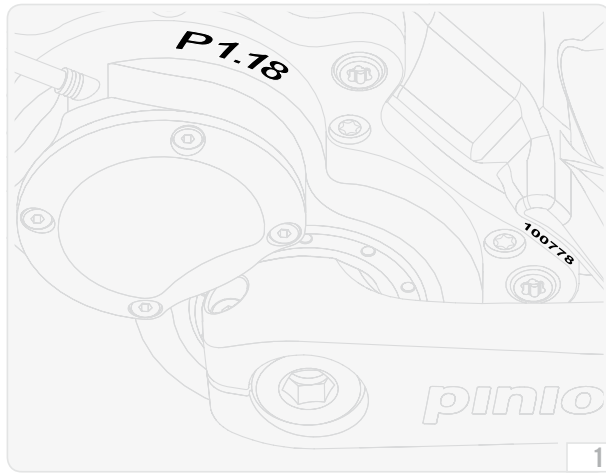

Keep this manual for other users of your Pinion product. Make sure that every user reads, understands and observes this manual.

If you ever sell or give away your Pinion product, give this manual to the new owner.

The illustrations in this manual may be different from your Pinion product, but the required work steps are the same for all models and variants – unless otherwise specified.

The type name of your Pinion bicycle transmission is stamped on the left side of the transmission above the transmission cover – the 6-digit serial number on the edge of case. (fig. 1)

Please note that the transmission will have a different feel compared to a chain transmission.

Familiarize yourself with your new Pinion bicycle transmission and the differences in your transmission during your initial rides.

See www.pinion.eu for many more tips and more information on your Pinion product.

We wish you all the best with your leisure and competitive riding.

The Pinion Team

TECHNICAL DATA

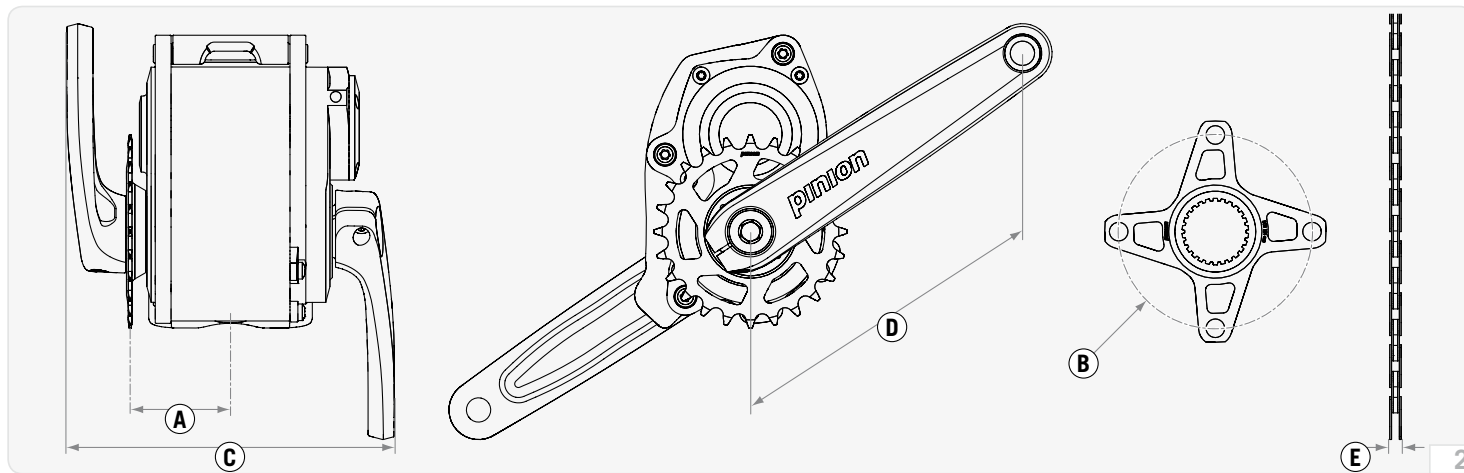

Type name		P1.18	P1.12	P1.9 ^{XR}	P1.9 ^{CR}
Chainline (A) – with Pinion chain ring	mm	54*			
Pitch circle \varnothing (B), Pinion chain ring spider		104			
Q-factor (C)		174			
Crank length** (D)		180/175/170/165/160/155			
Crank hub		Pinion Standard			
Dimension, chain (E)	mm	6.6–6.8 (9-speed)			
Gears via rotary shifter		18	12	9	
Gear ratio, total	%	636	600	568	364
Gear steps, constant		~ 11.5	~ 17.7	~ 24.3	~ 17.5
Ratio in 1 st gear		1.82			1.30
Ratio in the fastest gear		0.29	0.30	0.32	0.36
Oil volume/type	ml (oz)	60 (2.0)/Pinion			
Input torque max.	N·m (lbf·in)	250 (2213)			
Rider weight max.***	kg (lb)	110 (243)			

* If the Pinion chain ring spider is used, the chainline or beltline is defined by the contact surface (56mm) of the spider and the dimension/geometry of the chain ring or the belt sheave that is used – e.g.: 56mm + ½t = 58mm chainline (with symmetrical chain ring with thickness t=4 mm).

** optional

*** Rider + backpack etc.

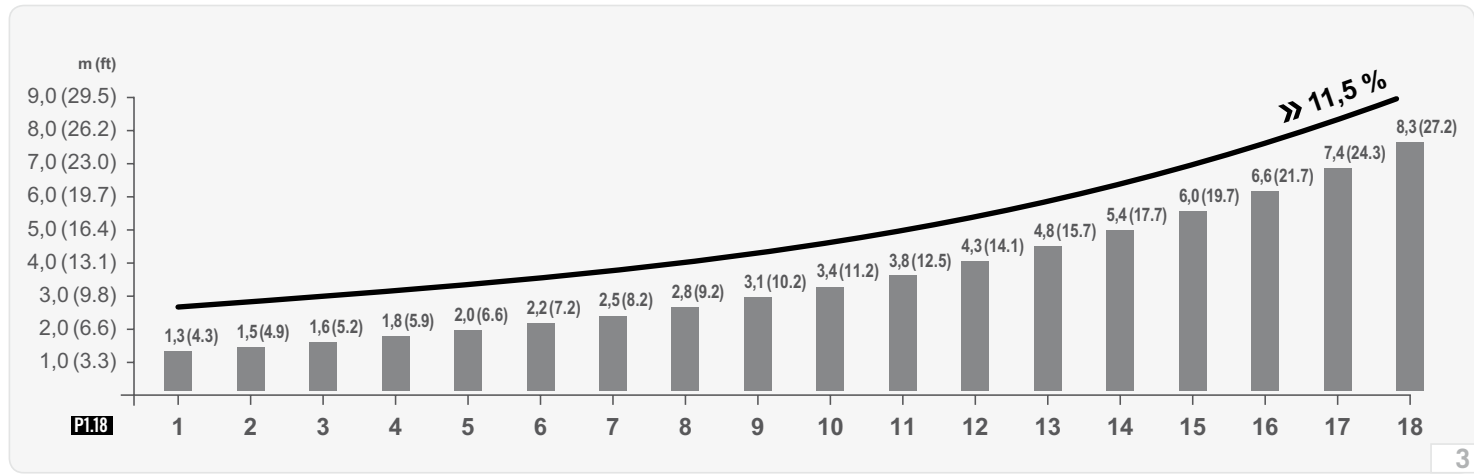

DEVELOPMENT

① **P1.18** The specified values in m (ft) per crank revolution correspond to the recommended ratio for sprocket (rear):chain ring (front) 21 : 24 = 0.875. The calculation is based on the tyre size 26x2.2 (55-559) (fig. 3).

'You can find a convenient program for calculating your individual ratio as well as the development values of other types of Pinion bicycle transmission at www.pinion.eu

TIGHTENING TORQUES

	Tightening torque in N·m (lbf·in) max.	
Transmission retaining screws	10 (89)	with screwlock, medium-strength
Central crank screws	10 (89)	with screwlock, medium-strength
Crank clamp screws	10 (89)	with screwlock, medium-strength
Chain ring lock ring	30 (266)	greased
Shift box housing screws	1.5 (13)	dry
Rotary shifter clamp screws	1 (9)	dry
Rotary shifter cover housing screws	0.25 (2)	dry
Cable clamp screws	0.4 (4)	dry
Oil screw plug	3 (27)	dry

SAFETY

INTENDED USE

⚠ WARNING

Use other than as intended may cause accidents resulting in death or serious injury.

- Pinion bicycle transmissions are designed and intended exclusively
- for installation on bicycle frames designed for the purpose with rigid rear triangle and a transmission bracket in the area of the bottom bracket.
 - for installation on bicycle frames designed for the purpose with suspension rear triangle and a transmission bracket in the area of the bottom bracket – and, if necessary, in combination with a suitable chain tensioner system that compensates for the distance between the chain ring and sprocket that varies with the movement of the suspension.
 - for use with a single-gear rear freewheel rear hub without a back pedal brake*.
 - for use with a rear cassette freewheel rear hub with spacers for setting the correct chainline.
 - for use with a rear wheel hub with an electric drive motor.
 - for use with a suitable chain tensioner system.
 - for the maximum approved rider weight – see **TECHNICAL DATA**, page 6.

Pinion bicycle transmissions must never be used in combination with a rigid single gear rear hub!

* A back pedal brake cannot be used with the freewheel integrated in the transmission!

BASIC SAFETY INSTRUCTIONS ...

Always remember that cycling can be dangerous for the rider and other people and also for the bicycle and its components. Accidents resulting in death or serious injury may happen even with the best protective equipment and all required safety devices.

Use your common sense and avoid dangerous actions.

... for installation & maintenance

⚠ WARNING

A transmission damaged as a result of faulty or non-approved installation may cause an accident.

- Don't overestimate your technical ability. Have all installation and maintenance work done by a specialist workshop for bicycles. That is the only way to be sure that the work is done correctly. You can find a list of Pinion bicycle dealers at **www.pinion.eu**
 - Installation work that is not described in this owner's manual (e.g. opening the transmission, retightening the housing screws, etc.) must be done exclusively by a specialist workshop authorized by Pinion or by the Pinion company itself. Do not attempt work of this type yourself – you will not only endanger your own health but you may be exposed to liability claims.
 - Never modify your Pinion product in any way (e.g. grinding, drilling, painting, etc.).
 - Always use a torque wrench designed for the required torque at installation steps that require a specific tightening torque.
 - Keep your bicycle in good technical condition at all times.
- Unsuitable accessories and additional components may cause accidents.**
- Use original Pinion parts and lubricants exclusively.
 - Use a rear wheel quick release system that reaches the required closing pressure of at least 4000N exclusively. It is best to use a rear hub that is permanently fastened with axle nuts in the rear

triangle, or which has a quick-release axle.

- Use exclusively a bicycle chain with a width of 6.6–6.8 mm (9-speed) and an appropriately sized sprocket, or a toothed belt system approved by Pinion.

... when on the road

⚠ WARNING

Component failure may cause accidents.

- Before every ride make sure that the quick release system of your wheels is correctly installed and that your wheels cannot be accidentally released.
- Before every ride make sure that your brakes are operating correctly and the brake pads are not excessively worn.
- Before every ride make sure your chain is correctly tensioned.
- Never exceed the maximum approved rider weight – see **TECHNICAL DATA**, page 6.
- Avoid jumping from a great height – this exposes your Pinion bicycle transmission to very high load peaks.
- Never ride with your Pinion bicycle transmission if damage (to the transmission housing, cranks, etc.) is visible, unusual noises can be heard, or you have any doubts about the transmission. Have your Pinion bicycle transmission checked by a specialist workshop for bicycles.
You can find a list of Pinion bicycle dealers at www.pinion.eu
- Do not ride with your Pinion bicycle transmission in ambient temperatures below -15 °C (5 °F) or above 40 °C (104 °F).

Incorrect riding behaviour or improper equipment may cause accidents.

- Always obey the traffic regulations of the country where you are riding your bicycle (lights, reflector, etc.) and also the regulations

governing off-road mountain biking.

- Always wear a good-quality, undamaged cycling helmet (e.g. ANSI-certified) and clothing that is close-fitting but does not hinder movement.
- Ride your bicycle only when you are in good physical condition and your bicycle and all its components are in good condition.

RUNNING IN THE TRANSMISSION

① The surfaces of the gears and transmission components are smoothed down over the first 500 km of cycling. Following that, the transmission will run more smoothly – with slick gearshifts.

Any roughness present in the drive or when shifting gear is normal when your Pinion bicycle transmission is new, and is nothing to be concerned about!

BEFORE EVERY RIDE

⚠ WARNING

Component failure may cause accidents.

- Before every ride make sure that the quick release system of your wheels is correctly installed and that your wheels cannot be accidentally released.
- Before every ride make sure that your brakes are operating correctly and the brake pads are not excessively worn.
- Before every ride make sure your chain is correctly tensioned.
- Never ride with your Pinion bicycle transmission if damage (to the transmission housing, cranks, etc.) is visible, unusual noises can be heard, or if you have any doubts the condition of the transmission. Have your Pinion bicycle transmission checked by a specialist workshop for bicycles.

A chain that continues to rotate when the crank is stationary because the sprocket or rear hub does not move easily during freewheel may cause an accident.

- Before every ride make sure that the sprocket and rear hub freewheel smoothly.

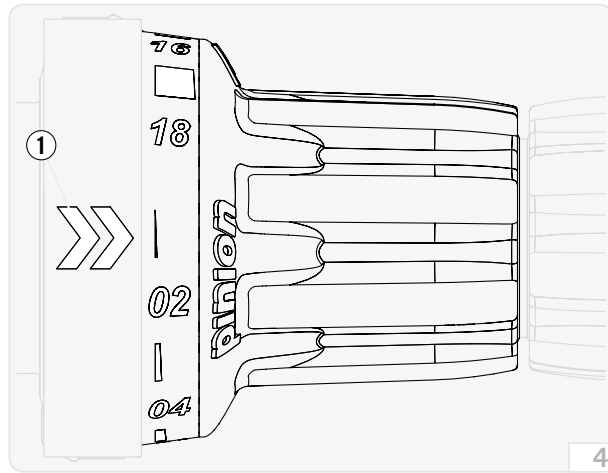

SHIFTING CORRECTLY

- ① The mark (1) on the fixed part of the rotary shifter shows the selected gear (fig.4).
- ① You can shift through several gears with one movement (e.g. from 06 to 02). You cannot shift directly from 01 to the fastest gear or from the fastest gear to 01.
- ① You can shift at a standstill or with the crank rotating backwards and this protects the transmission.
- ① Downshifting (18-17-16- ... -01) under load is possible to a limited extent. To protect the transmission, the shift is not executed if the pressure on the crank or pedal is too high.
- ① A mechanism in the transmission allows upshifts (01-02- ... -18) under load. This is possible during all gear shifts, except when shifting between each of the sub-units. At these points the pressure on the pedal must be momentarily released.
 - ☞ Always reduce the pressure on the pedal during downshifts (18-17-16- ... -01).
 - ☞ **P1.18** When shifting up from 06 to 07 and from 12 to 13 always reduce the pressure on the pedal.
 - ☞ **P1.12** When shifting up from 04 to 05 and from 08 to 09 always reduce the pressure on the pedal.
 - ☞ **P1.9⁹⁸** **P1.9⁹⁹** When shifting up from 03 to 04 and from 06 to 07 always reduce the pressure on the pedal.

INSTALLATION WORK

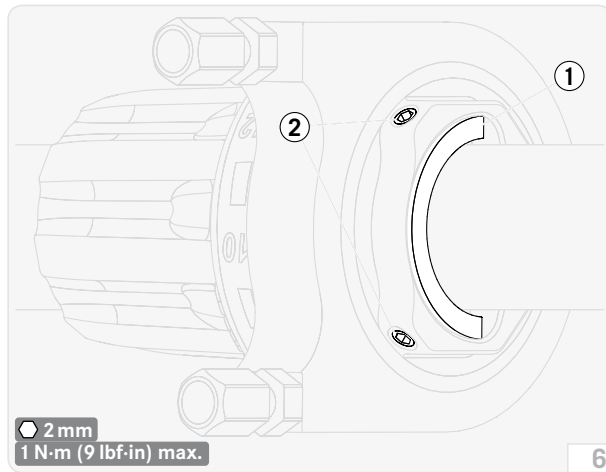
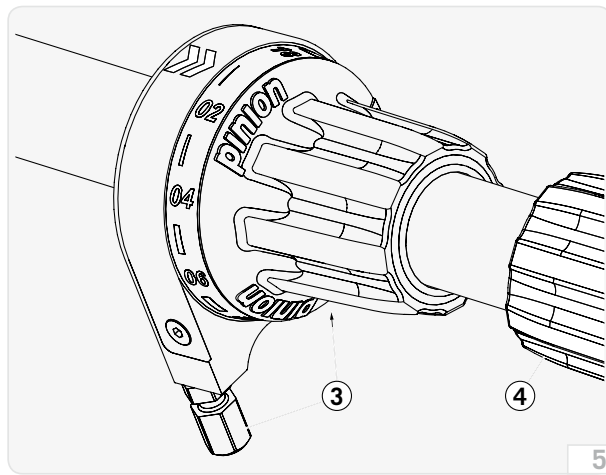

INSTALLING ROTARY SHIFTER

⚠ WARNING

Incorrect installation may restrict braking and steering and cause accidents.

- Make sure that the position of the rotary shifter does not interfere with the full range of operation of the brake lever.
- Make sure that the derailleur cables do not interfere with the handlebar movement.

Incorrectly mounted handlebars may fail and cause an accident.

- Make sure that the clamp ring (1) is present, the clamp screws (2) do not act directly on the handlebar surface (fig. 6).
- Always follow the manufacturer's directions for carbon handlebars.

ⓘ The Pinion rotary shifter is generally correctly positioned with the adjusting screws (3) for the derailleur cable pointing down and slightly forward – i.e. in the 4–5 o'clock direction (fig. 5).

In this position you can best see the current gear and the derailleur cables do not interfere with the brake lever.

ⓘ In the event of a fall it is advantageous if the brake lever and rotary shifter can twist. This reduces the danger of irreparable damage – including the handlebar. Tighten the clamp screws of the brake lever and rotary shifter just tight enough so they cannot be twisted by hand.

- 🔧 Use carbon assembly paste on the clamp area for carbon handlebars.
- 🔧 Attaching rotary shifter to the handlebar.
- 🔧 Attach rotary shifter (4) and if applicable bar end to the handlebar (fig. 5).
- 🔧 Push rotary shifter onto the handle of the handlebar to the stop and rotate to the correct position.
- 🔧 Tighten the two clamp screws (2) alternately in stages – do not exceed the maximum tightening torque of 1 N·m (9 lbf·in) under any circumstances (fig. 6).

➔ The installation of the rotary shifter is complete.

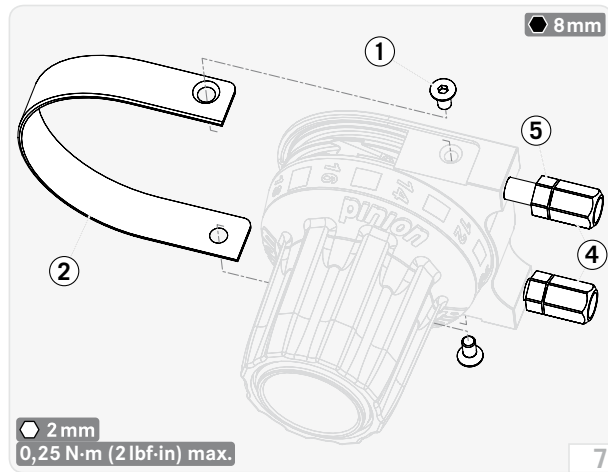

INSTALLING OR REPLACING PULLING CABLES

- ① You operate your Pinion bicycle transmission with 2 pulling cables. The clamps for the pulling cable ends are in the rotary shifter. It is essential that you use commercially available derailleur inner cables with dimension \varnothing 1.2 mm, nipple 4.4×4.4 mm. Genuine Pinion derailleur cables guarantee optimum shifting behaviour and can be ordered directly from Pinion or from any Pinion bicycle dealer.
- ① During installation of the pulling cables, you will need to move the sun gear of your Pinion bicycle transmission, so it is a good idea if the right crank and chain ring are fitted. This makes it much easier for you to brace the transmission shaft.
- ☞ Unscrew the housing screws (1) of the cover (2) on the rotary shifter.
 - ☞ Remove the cover.

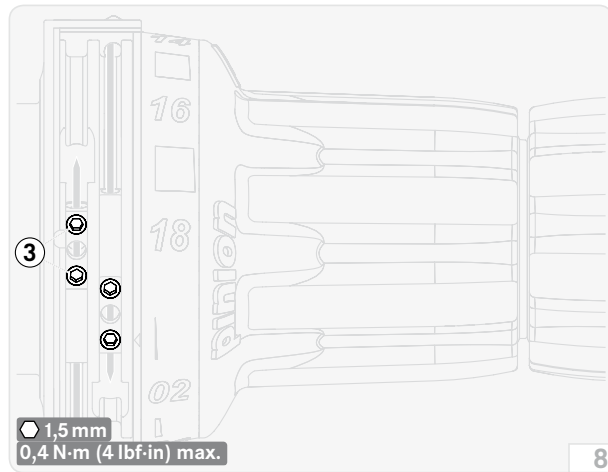

- ① The clamp screws are easily accessible at rotary shifter positions **01 and 18** or **01 and 12** or **01 and 09** depending on the type of your pinion bicycle transmission.
- ☞ Slacken clamp screws (3) – 2× per pulling cable end.
 - ☞ Pull the pulling cables out of the rotary shifter.
 - ☞ Cut off the spliced-on pulling cable ends with a sharp wire cutter.
- ☞ Hold adjusting screws (4) and slacken lock nuts (5) (fig. 7).
 - ☞ Screw the lock nuts to the stop on the heads of the adjusting screws.
 - ☞ First, screw in adjusting screws completely – then unscrew three revolutions.
 - ➔ This ensures an adequate adjustment range for subsequent adjustments of the transmission.

INSTALLATION WORK

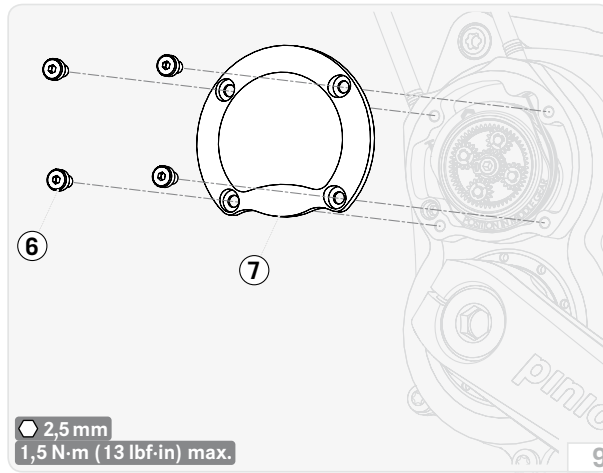

- ☞ Unscrew housing screws (6) of the transmission cover (7).
- ☞ Remove the transmission cover.

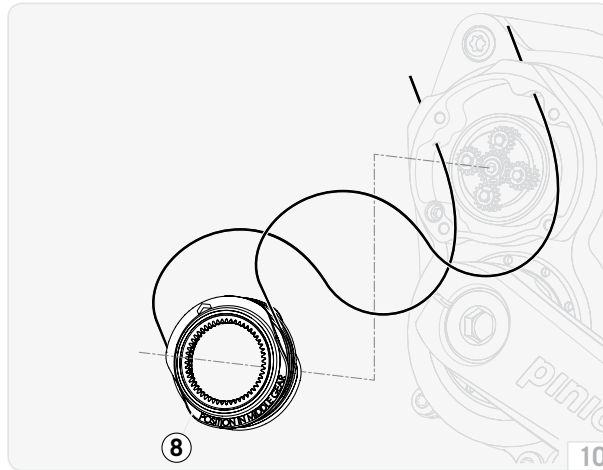

- ☞ Remove the pulling cable helix (8) with the pulling cables from the transmission housing.
- ☞ Remove the pulling cables from the pulling cable helix.
- ☞ Thoroughly clean the pulling cable helix.

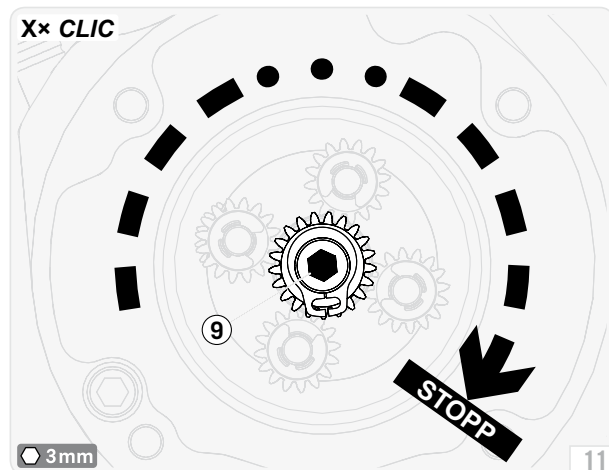

- ☞ Hold crank and chain ring in position.
- ☞ Rotate sun gear (9) clockwise to the stop with a 3 mm Allen wrench.
- 1st gear is engaged.

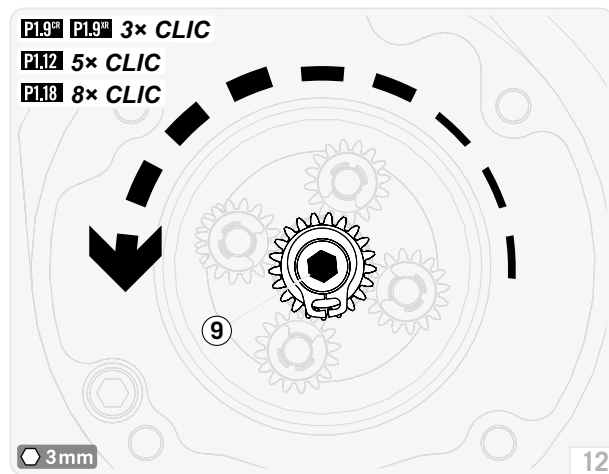

- ☞ Hold crank and chain ring in position.
- ☞ **P1.9^m P1.9^m 3× CLIC**
- ☞ **P1.12 5× CLIC**
- ☞ **P1.18 8× CLIC**
- ☞ **P1.18** Rotate sun gear (9) **8 clicks** counterclockwise with 3 mm Allen wrench.
- **9th gear** is engaged.
- or:
- ☞ **P1.12** Rotate sun gear (9) **5 clicks** counterclockwise with 3 mm Allen wrench.
- **6th gear** is engaged.
- or:
- ☞ **P1.9^m P1.9^m** Rotate sun (9) gear **3 clicks** counterclockwise with 3 mm Allen wrench.
- **4th gear** is engaged.

INSTALLATION WORK

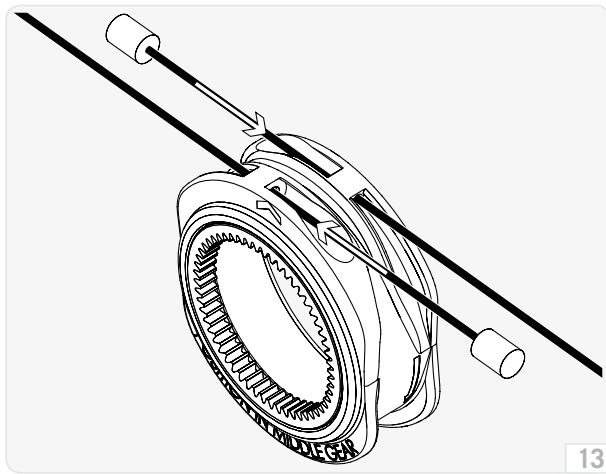

13

☞ Insert new pulling cables through the holes in the pulling cable helix.

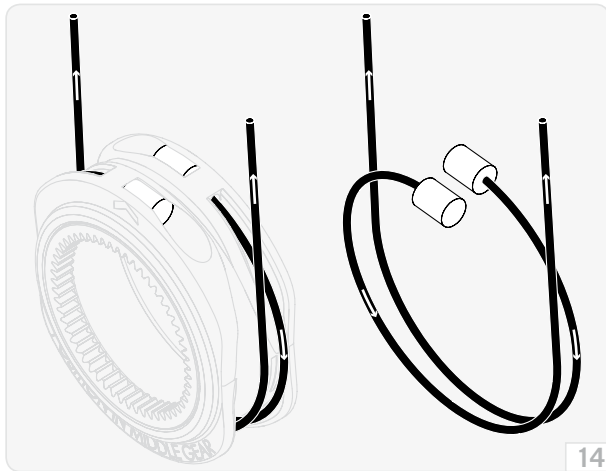

14

- ☞ Wind each of the pulling cables $\frac{3}{4}$ revolution around the pulling cable helix (fig. 14).
- ☞ Hold the pulling cables with the pulling cable helix with 1 hand so the pulling cables cannot unwind.

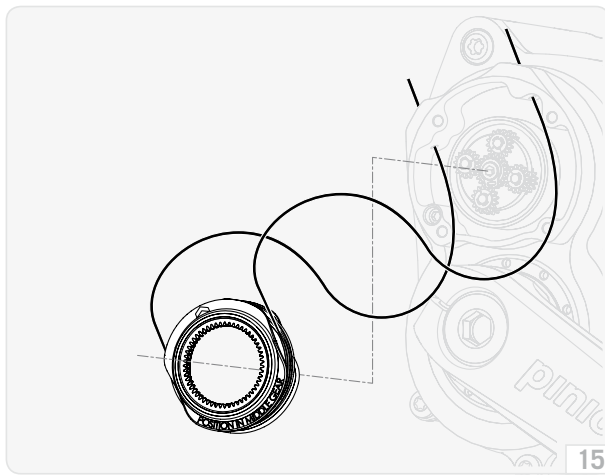

- ☞ Insert the pulling cables through the holes in the transmission housing (fig. 15).
- ☞ Keep the pulling cables taut.

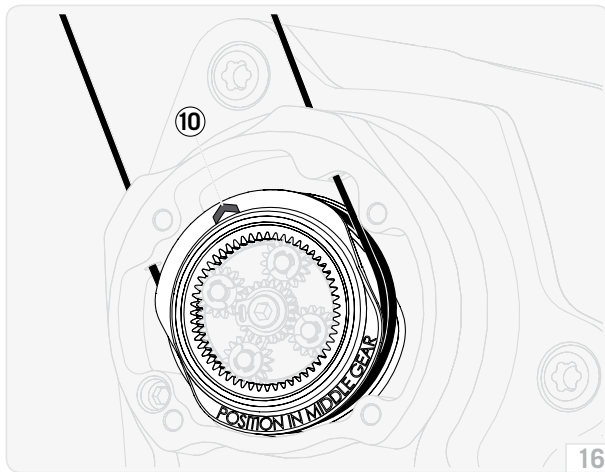

- ☞ Insert pulling cable helix into the transmission housing (fig. 16).
- ☞ Make sure that the marking (10) of the pulling cable helix is centrally positioned between the transmission housing holes.
- ☞ Keep the pulling cables taut.

INSTALLATION WORK

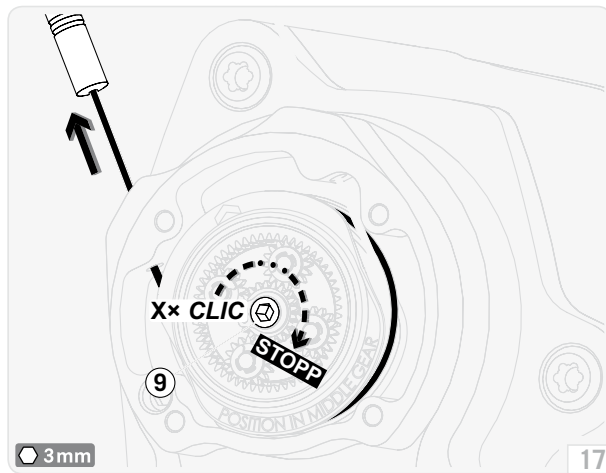

- ☞ Rotate sun gear (9) clockwise to the stop with a 3 mm Allen wrench.
- 1st gear is engaged.
- ☞ Insert the left pulling cable through the derailleur cable outer sleeve.

NOTICE

The pulling cables have a tendency to come unspliced on outer sleeve end caps made from metal.

- Use outer sleeve end caps made from plastic (Ø 5.8mm).

- ☞ Make sure that both pulling cables are positioned correctly in the pulling cable guides (fig. 14).

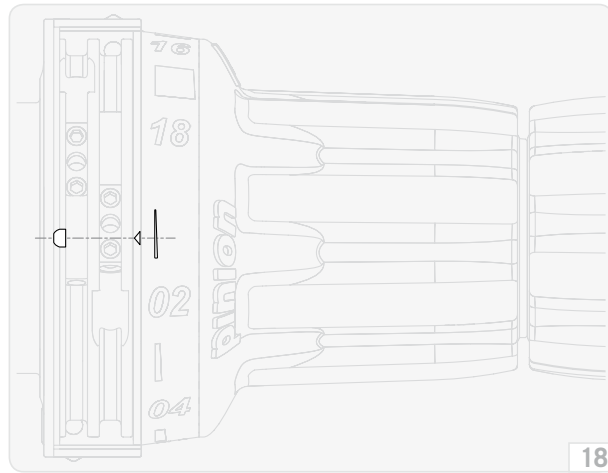

☞ Switch rotary shifter to position 01 (fig. 18).

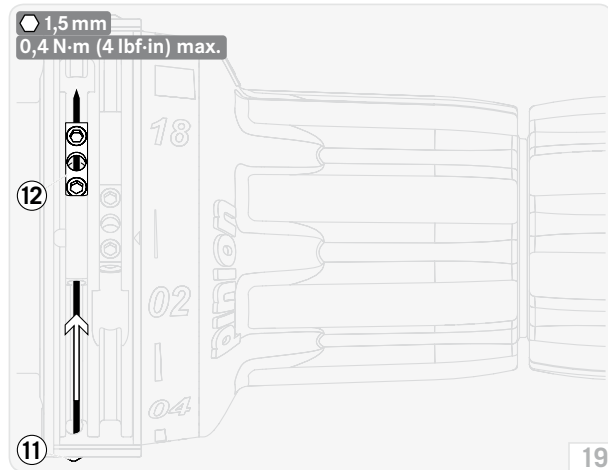

- ☞ Insert the left end of the pulling cable into the internal – towards the centre of the handlebar – adjusting screw (11), rotary shifter housing and clamp (12).
- ☞ Keep the left end of the pulling cable under tension (fig. 19).
- ☞ Make sure that the ends of the derailleur cable outer sleeve are firmly in the stops on the adjusting screw and transmission housing.
- ☞ Tighten the two clamp screws alternately with a tightening torque of 0.4 N·m (4 lbf·in).
- ☞ Cut the left end of the pulling cable as close as possible to the clamp with a sharp wire cutter.
- ① Pry the clamp out of its seat somewhat. Then, it will be easier to cut off the end of the pulling cable.
Following that, make sure that the clamp is once again located in its seat up to the stop.

INSTALLATION WORK

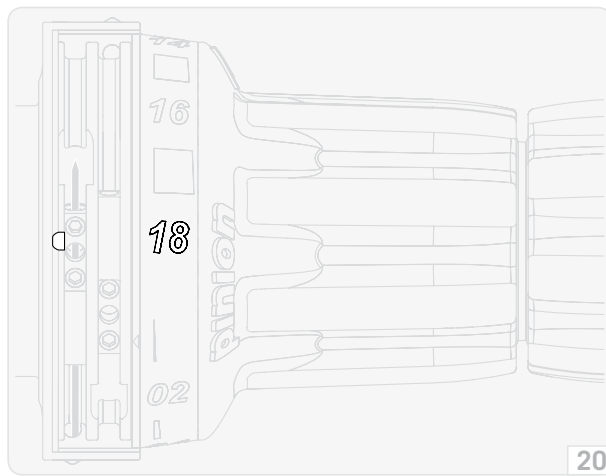

☞ **P1.18** Rotate rotary shifter clockwise (01-02-03- ... -18) to position 18 (fig. 20).

or:

☞ **P1.12** Rotate rotary shifter clockwise (01-02-03- ... -12) to position 12.

or:

☞ **P1.9⁹** **P1.9⁹** Rotate rotary shifter clockwise (01-02-03- ... -09) to position 09.

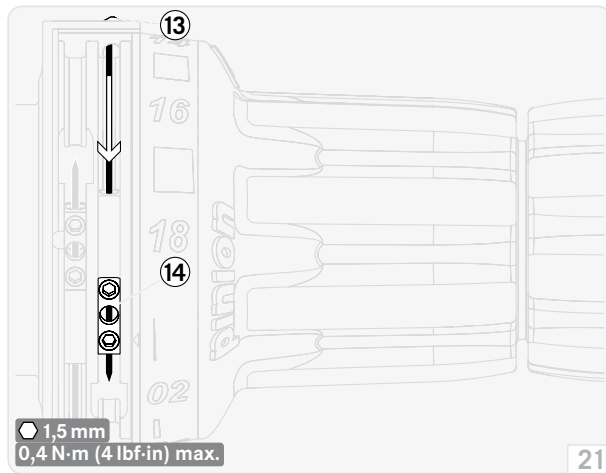

☞ Insert the right pulling cable through the derailleur cable outer sleeve.

☞ Make sure that both pulling cables are positioned correctly in the pulling cable guides (fig. 14).

☞ Insert the right end of the pulling cable into the outer – towards the end of the handlebar – adjusting screw (13), rotary shifter housing and clamp (14).
☞ Keep the right end of the pulling cable under tension. (fig. 21).

☞ Make sure that the ends of the derailleur cable outer sleeve are firmly in the stops on the adjusting screw and transmission housing.

☞ Tighten the two clamp screws alternately with a tightening torque of 0.4 N·m (4 lbf·in).

☞ Cut off the right end of the pulling cable as close as possible to the clamp with a sharp wire cutter.

ⓘ Pry the clamp out of its seat somewhat. Then, it will be easier to cut off the end of the pulling cable.

Following that, make sure that the clamp is once again located in its seat up to the stop.

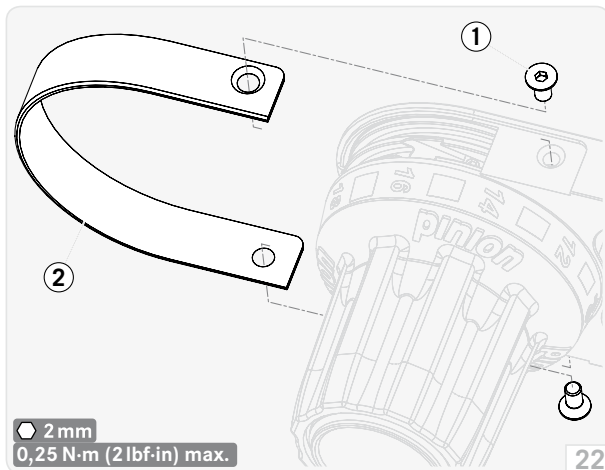

- ☞ Position cover (2).
- ☞ Tighten housing screws (1) with a tightening torque of 0.25 N·m (2 lbf·in).
- ☞ Test shifting function, if necessary adjust cable tension with the adjusting screws – see **ADJUSTING SHIFTING**, page 29.

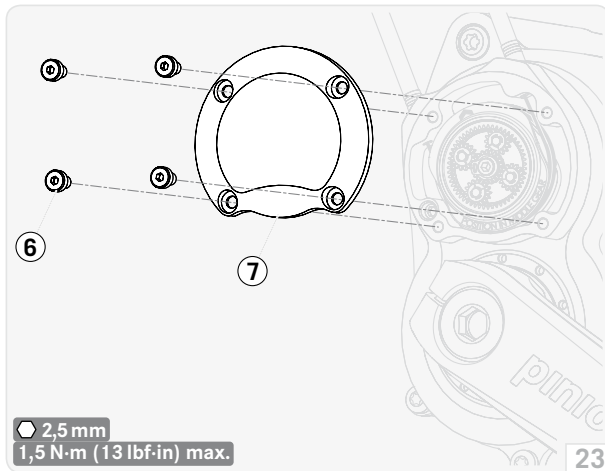

- ☞ Position transmission cover (7).
 - ☞ Tighten housing screws (6) with a tightening torque of 1.5 N·m (13 lbf·in).
- The replacement of the derailleur cables is complete.

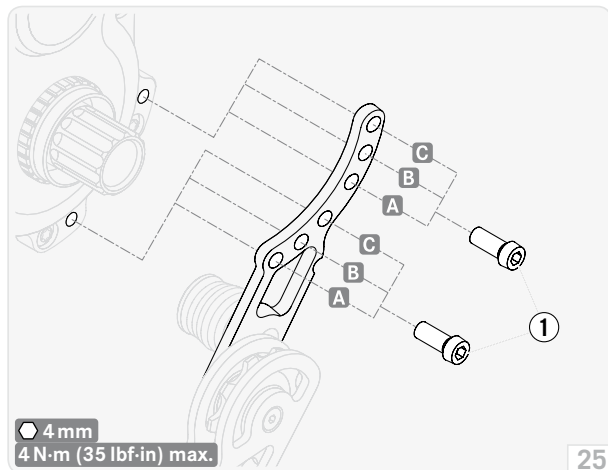

INSTALLING PINION CHAIN TENSIONER

⚠ WARNING

If a chain tensioner fails because of improper use, it may cause an accident.

The Pinion chain tensioner is designed and intended exclusively for use with a Pinion bicycle transmission.

- Always install the Pinion chain tensioner on the retaining positions on your Pinion bicycle transmission only.

① The Pinion chain tensioner can be mounted on your Pinion bicycle transmission in one of 3 different positions: **A**, **B** or **C** (fig. 25).

The selection of the correct position depends on the installation position selected by the manufacturer of your bicycle for the Pinion bicycle transmission. Make sure that your Pinion chain tensioner transfers the tension effect in full to your bicycle chain in the position that you select, but also cannot contact the chain stay or tyre of your bicycle at any position.

- ☞ Remove chain.
- ☞ Remove crank and chain ring – see **REPLACING CHAIN RING**, page 24.
- ☞ Tighten retaining screws (1) with a tightening torque of 4 N·m (35 lbf·in).
- ☞ Install crank and chain ring – see **REPLACING CHAIN RING**, page 24.
- ☞ Position chain and guide it through the tension mechanism (fig. 26).
- ☞ Connect chain.

① Your chain has the correct length if the tension mechanism of the chain tensioner is pretensioned (2), but can still be moved upwards (3) further (fig. 26).

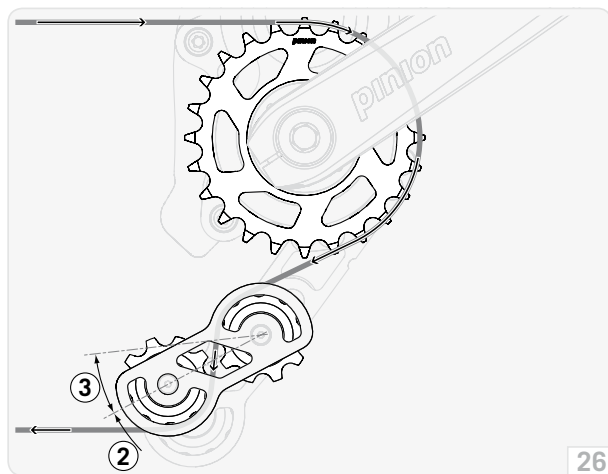

NOTICE

In full-suspension bicycles, always check the chain length or the mobility of the chain tensioner mechanism with the rear triangle suspension fully compressed!

- The installation of the Pinion chain tensioner is complete.

ADJUSTING CHAIN TENSION (PINION CHAIN TENSIONER)

① If your chain frequently hits the chain stay on your bicycle frame while you are riding, it may be necessary to increase the chain tension.

If the chain or cranks continue to rotate although the rear wheel freewheel is operating correctly, or if the chain tensioner rattles, it may be necessary to reduce the chain tension.

① Before proceeding with the following actions, make sure that your chain is the correct length – see **INSTALLING PINION CHAIN TENSIONER**, page 22.

- 🔧 Remove the chain and take it off the chain ring and sprocket.
- 🔧 Disconnect the spring leg (1) at the tension mechanism (2).
- 🔧 Rotate the tension mechanism forward.
- 🔧 The screw (3) of the spring shaft is accessible.

🔧 Unscrew the screw (3) of the spring shaft (4).

🔧 Pull the spring shaft out of the baseplate (6).

🔧 Move the spring end pin (5) counterclockwise (+).

➔ The chain tension is increased.

or:

🔧 Move the spring end pin (5) clockwise (-).

➔ The chain tension is reduced.

🔧 Insert the spring shaft into the baseplate (6).

🔧 Screw in the screw (3) of the spring shaft (4) and tighten with a tightening torque of 4 N·m (35 lbf·in).

🔧 Position the chain on the chain ring and sprocket.

🔧 Attach spring leg (1) to tension mechanism (2).

🔧 Check the setting.

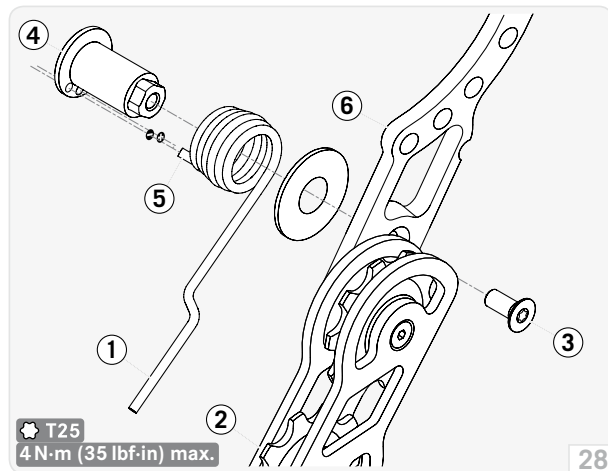
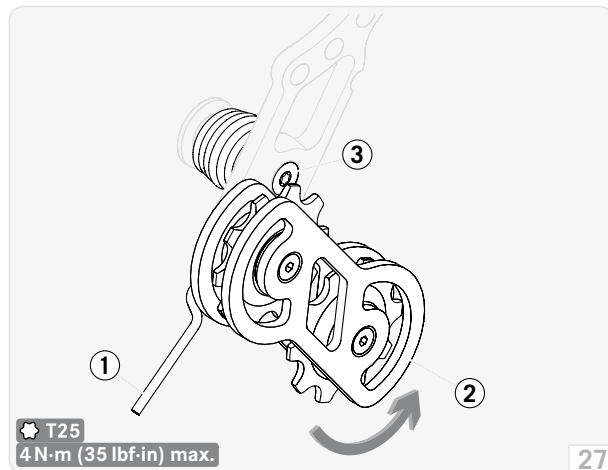

INSTALLATION WORK

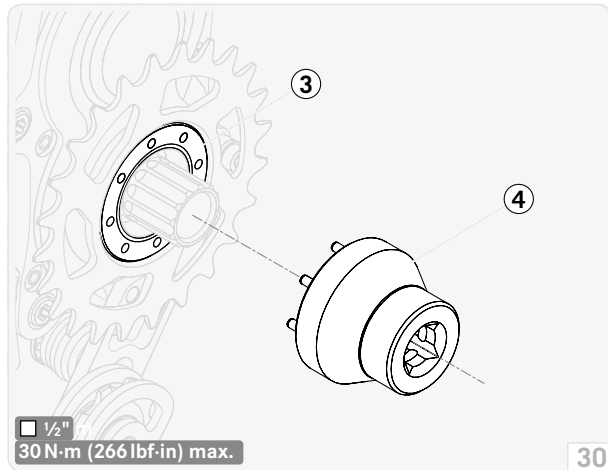
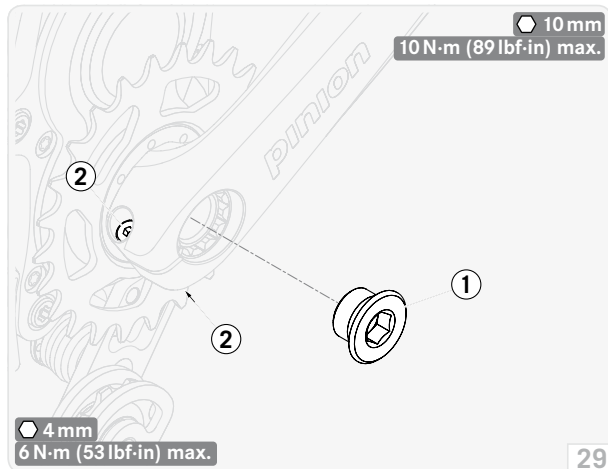

REPLACING CHAIN RING

- ① If you need to replace the chain ring of your Pinion bicycle transmission (because of wear, different gear ratio, replacement by chain ring spider), you can order it and the required tool directly from us. See www.pinion.eu for a selection of different chain rings.
- ① Another method of changing the gear ratio is to replace the sprocket on your rear wheel.
- ① Chain ring, sprocket and chain always wear on opposite sides during use. This means that the drive might stop working without problems (chain disengages, more noise) if only one of these parts is replaced. We recommend always replacing all these parts if one needs replacing.

- 🔧 Remove chain.
- 🔧 Unscrew centre screw (1).
- 🔧 Slacken both clamp screws (2) on the crank.
- 🔧 Pull the crank from the input shaft.
- 🔧 Hold chain ring with chain whip or at the left crank.
- 🔧 Unscrew lock ring (3) clockwise (left-hand thread!) with the Pinion lock ring tool (4).
- 🔧 Remove chain ring.
- 🔧 Make sure that the gears (5) and contact surfaces on the transmission side and the chain ring (6) or chain ring spider (7), disc (8) and lock ring (3) are clean and free from old grease.
- 🔧 Lightly grease gears (5).
- 🔧 Put on the chain ring or chain ring spider (with chain ring fitted).
- 🔧 Lightly grease the contact areas of the disc (8).
- 🔧 Insert the disc in the chain ring or chain ring spider.

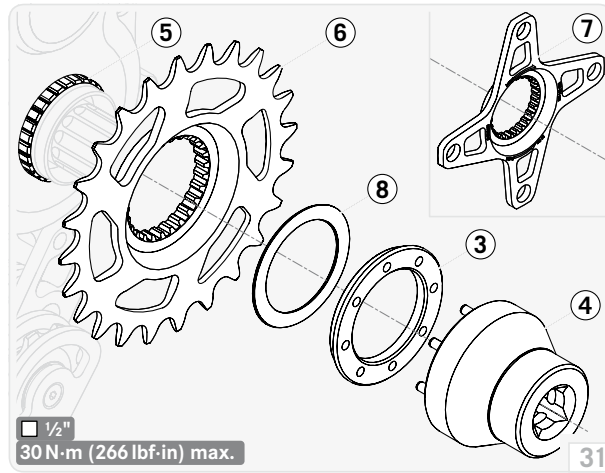

- ☞ Lightly grease the contact area and thread of lock ring (3).
- ☞ Screw in lock ring counterclockwise (left-hand thread!) with the Pinion lock ring tool (4).
- ☞ Hold chain ring with chain whip or at the left crank.
- ☞ Tighten lock ring (3) with a tightening torque of 30 N·m (266 lbf·in).
- ☞ Fit a new chain if necessary – see **CHAIN LENGTH & CHAIN TENSION**, page 26.
- ➔ The replacing of the chain ring is complete.

INSTALLING CRANKS

- ① To protect the gears (9) on the input shaft and cranks from one-sided loads, it is a good idea to remove both cranks regularly (1× a year) and to reinstall them offset by 1–2 teeth and with fresh carbon assembly paste (e.g. *DYNAMIC*).
- ☞ Make sure that the gears (9) on the input shaft and crank are clean and free from old grease.
- ☞ Make sure that both clamping screws (2) have washers and medium-strength screwlock – it is best to use lock washers.
- ☞ Apply a light coating of carbon assembly paste to the gears.
- ☞ Position crank and push it manually on the input shaft to the stop, if necessary carefully spread it with a wide screwdriver – do not use any impact tools (hammer etc.).
- ☞ Screw in centre screw (1) and tighten with a tightening torque of 10 N·m (89 lbf·in).
- ① The crank can now be moved by another 1–2 mm on the input shaft – this is normal and no reason for concern!
- ☞ Pull the crank outward as far as the stop.
- ☞ Tighten the clamp screws (2) in stages and alternately until both clamp screws have reached a tightening torque of 10 N·m (89 lbf·in).

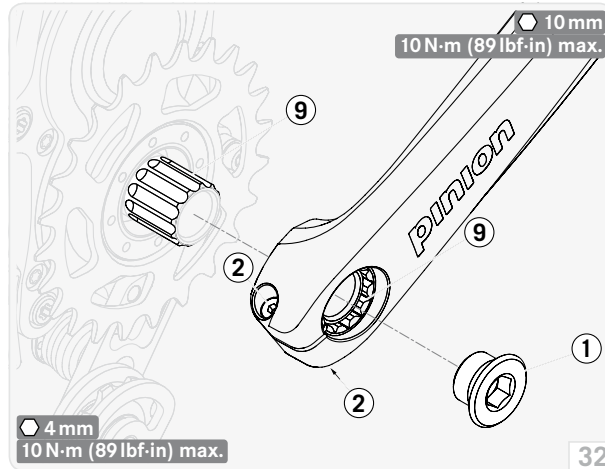

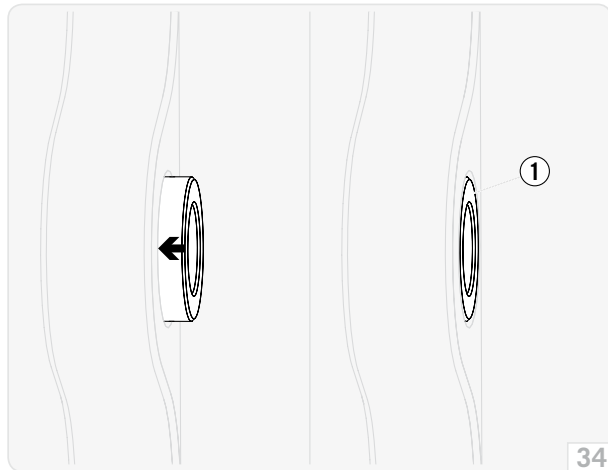
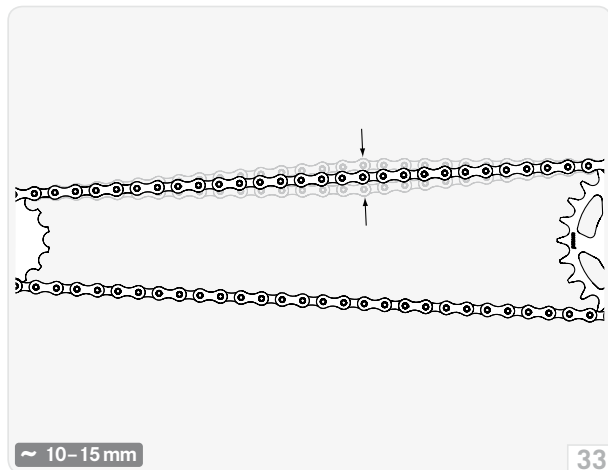

CHAIN LENGTH & CHAIN TENSION

- ① The correct length of your bicycle chain depends on various factors:
- The number of teeth on the sprocket and chain ring – after replacement it may be necessary to determine the chain length again.
 - Suspension travel and type of spring rear hub of your bicycle frame – follow the manufacturer's instructions.
 - Type of chain tensioner or tensioning system (horizontal dropout ends with clamp screws) – follow the manufacturer's instructions.
- ① The basic rule for the length of your bicycle chain is as short as possible and as long as necessary. The function and adjustment range of your chain tensioner and the complete suspension of the rear triangle must not be impaired.

NOTICE

Accelerated wear of the complete drive because of excessively high chain tension.

- For direct tension (horizontal dropouts with clamp screws) make sure that the chain has approx. 10–15 mm play (fig. 33).

Accelerated wear of the complete drive because of crooked chain running.

- Make sure that the gaps between your rear hub and the chainline of your Pinion bicycle transmission match – see **TECHNICAL DATA**, page 6.

INSTALLING TRANSMISSION

NOTICE

Incorrect installation may distort and damage the transmission.

- Make sure that all 4 key sleeves (1) (fig. 34/35) are installed flat in their seats in the transmission housing – if necessary, press in with a parallel pressing tool (e.g. screw clamp, suitable clamp, etc.) (fig. 34).
- Follow the sequence and tightening torque (fig. 35).

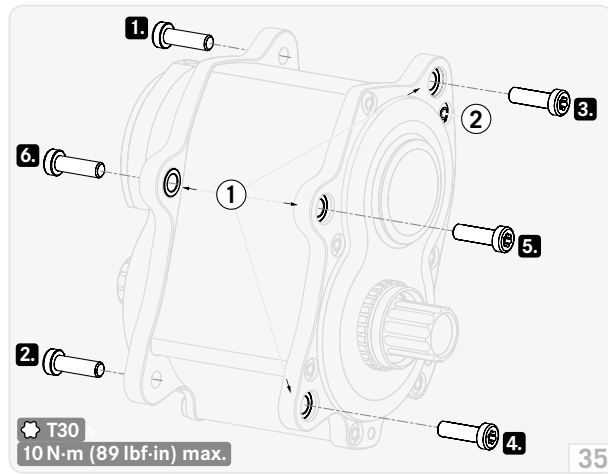

- ☞ Make sure that all contact points between the transmission and bicycle frame bridge are clean and coated with carbon assembly paste (e.g. *DYNAMIC*).
 - ☞ Apply fresh screw locking fluid (medium) to the transmission retaining screws.
 - ☞ Position transmission in the bicycle frame bridge.
 - ☞ Install all retaining screws.
 - ☞ Tighten retaining screws in the specified sequence (fig. 35) with a tightening torque of 10 Nm (89 lbf·in).
- The installation of the transmission is complete.

NOTICE

Housing screws (2) are stress bolts. They are not allowed to be retightened under any circumstances and – once unscrewed – must be replaced by new ones! (fig. 35)

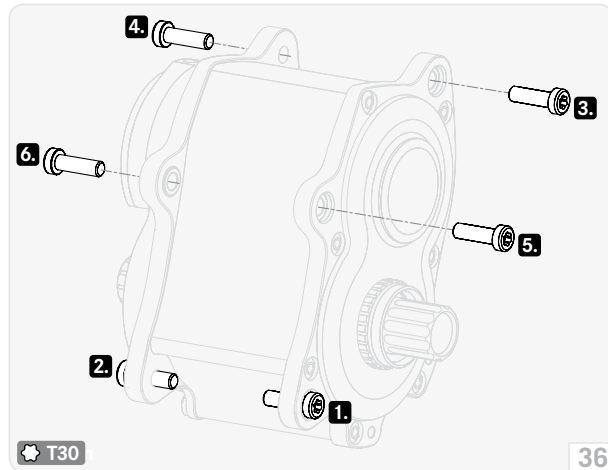

REMOVING TRANSMISSION

- ☞ Unscrew the pulling cable at the rotary shifter – see **INSTALLING OR REPLACING PULLING CABLES**, page 13.

⚠ CAUTION

Danger of injury if the transmission drops down – approx. 2.7 kg (6 lb) weight.

- Get a helper to secure the transmission during removal.

- ☞ Initially only loosen the 2 bottom retaining screws (fig. 36).
- ☞ Unscrew the 4 upper retaining screws.
- ☞ If necessary, remove the transmission from the bicycle frame bridge with assembly irons, and tilt it downwards.
- ☞ Get a helper to secure the transmission.
- ☞ Unscrew the 2 lower retaining screws.
- ☞ Remove transmission in the bicycle frame bridge.

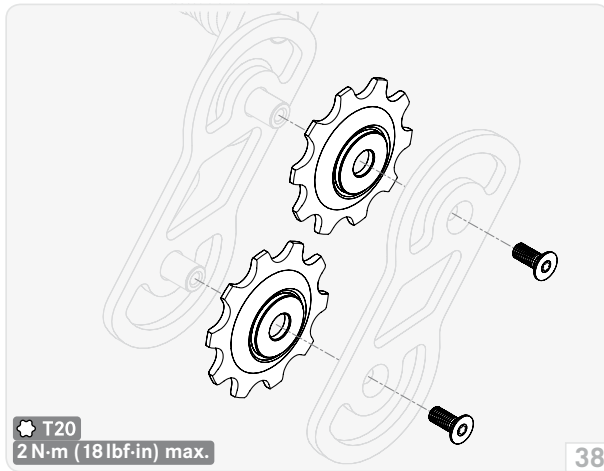
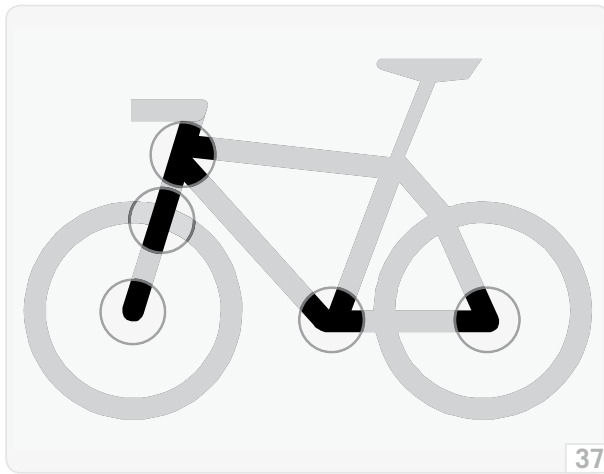

FREQUENCY

- ① The frequency of use and weather conditions determine the frequency of maintenance work on your Pinion bicycle transmission. Carry out the following maintenance operations more frequently if you use your bicycle under extreme conditions (rain, dirt, long distances etc.).

NOTICE

Corrosion and material damage by penetration of water.

- Never use a pressure cleaner or steam cleaner to clean your bicycle – the seals in the bicycle components cannot withstand this pressure.
- Be careful even if you use an ordinary hose. Never direct a spray of water directly at the areas of a seal (fig. 37).

- ☞ Clean the transmission housing with water, detergent and a brush.
- ☞ Clean the chain, chain ring, sprocket and, if necessary, the rollers of the chain tensioner.
- ☞ Oil the chain lightly.

NOTICE

Housing screws (2) are stress bolts. They are not allowed to be retightened under any circumstances and – once unscrewed – must be replaced by new ones! (fig. 35)

- ☞ Check that all screw fasteners – except housing screws – have the required tightening torque and adjust if necessary.
- ☞ Check the tension and smoothness of the derailleur cable – see **ADJUSTING SHIFTING**, page 29.
- ☞ Check the chain tension – see **CHAIN LENGTH & CHAIN TENSION**, page 26.
- ☞ Correct the chain tension if necessary – see **ADJUSTING CHAIN TENSION (PINION CHAIN TENSIONER)**, page 23.
- ☞ Check that the chain tensioner rollers move smoothly and inspect for wear (excessive play, loud running noises) – replace rollers if necessary (fig. 38).

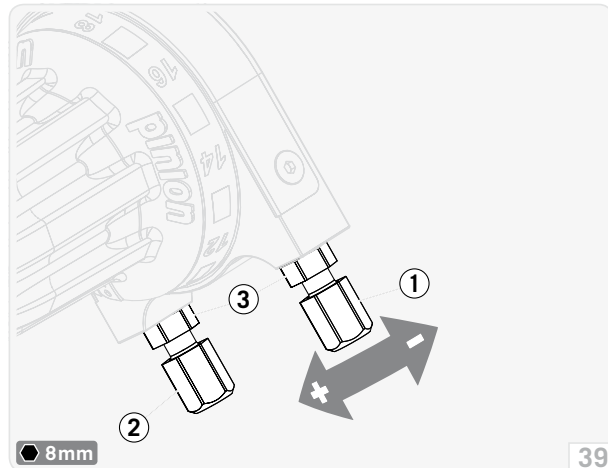

ADJUSTING SHIFTING

① Your Pinion bicycle transmission is correctly adjusted if it shifts immediately (cable tension), all gears can be selected with minimum force (cable tension) and the display on the rotary shifter matches the selected gear (synchronization).

☞ Hold adjusting screws (1) (2) and slacken lock nuts (3) (fig. 39).

Adjusting cable tension

① The cable tension is in the correct range if the ends of the derailleur cable outer sleeves are within the stops on the transmission and rotary shifter without play and are not under tension and it has approx. 2 mm rotary play.

☞ Unscrew both adjusting screws $\frac{1}{4}$ revolution counterclockwise (+).

→ Cable tension is increased.

→ Force required is increased.

or:

☞ Screw in both adjusting screws $\frac{1}{4}$ revolution clockwise (-).

→ Cable tension is reduced.

→ Play on the rotary shifter is increased, shift is less immediate.

Synchronizing position of rotary shifter

☞ Shift rotary shifter clockwise (01–02–03– ...) to the stop towards the last position (18 or 12 or 09) (fig. 40).

☞ Check that the symbol for the last position (18 or 12 or 09) is centrally placed beside the mark (4).

☞ Screw in adjusting screw (1) $\frac{1}{4}$ revolution clockwise (-).

☞ Unscrew adjusting screw (2) $\frac{1}{4}$ revolution counterclockwise (+).

→ The rotary shifter scale moves towards position 17 or 11 or 08.

or:

☞ Unscrew adjusting screw (1) $\frac{1}{4}$ revolution counterclockwise (+).

☞ Screw in adjusting screw (2) $\frac{1}{4}$ revolution clockwise (-).

→ The rotary shifter scale moves towards position 01.

☞ Check setting and repeat procedure if necessary

☞ Hold adjusting screws (1) (2) and tighten lock nuts (3) with a tightening torque of 2–3 N·m (18–27 lbf·in) (fig. 39).

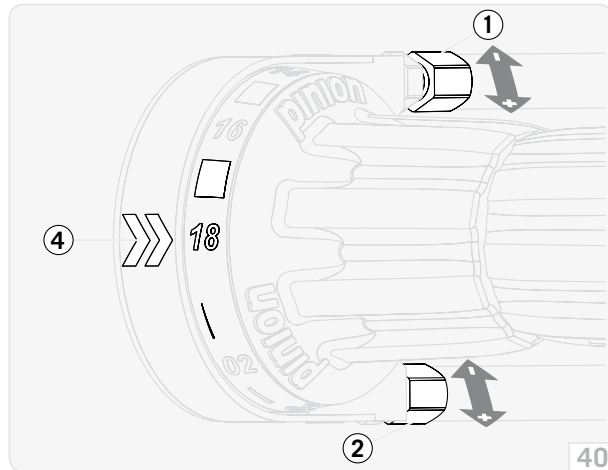

MAINTENANCE WORK

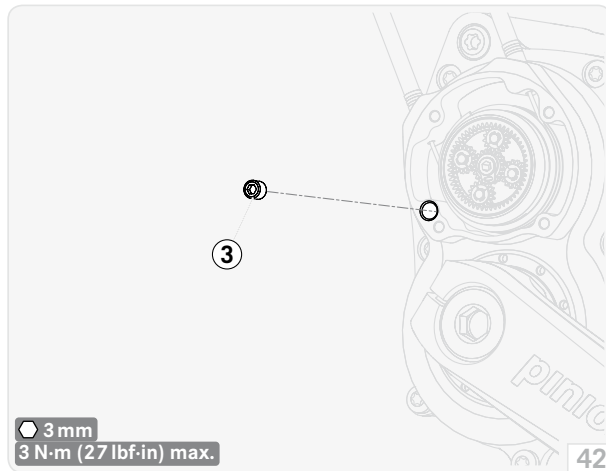
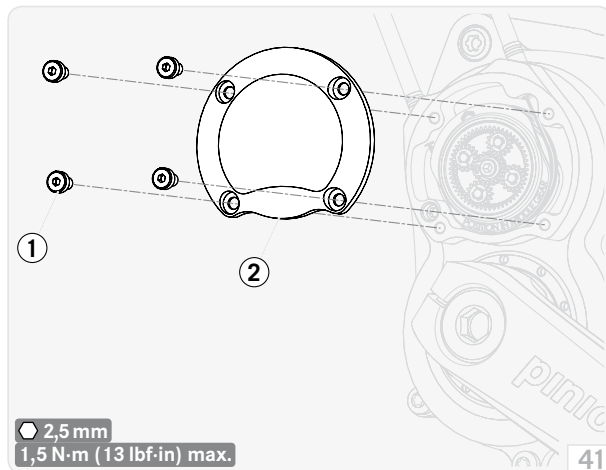

OIL CHANGE

- ① Every 10 000 km (6 200 miles) or 1× per year the oil in your Pinion bicycle transmission must be changed.
Use original Pinion transmission oil exclusively.
Oil volume – see **TECHNICAL DATA**, page 6.

NOTICE – ENVIRONMENT

Dispose of used lubricants and oils correctly and in accordance with the applicable regulations – never dispose of waste in the sewage system or in the ground.

- ☞ Unscrew housing screws (1) of the transmission cover (2).
 - ☞ Remove the transmission cover.
 - ☞ Unscrew the screw plug (3) in the filler opening.
 - ☞ Have a drainage tray ready.
 - ☞ Place bicycle on its side.
 - ☞ Drain used oil completely from the filler opening into the drainage tray.
 - ☞ Place the bicycle upright or replace on repair stand.
 - ☞ Add fresh oil, fill volume – see **TECHNICAL DATA**, page 6.
 - ☞ Replace screw plug (3) in filler opening and tighten with a tightening torque of 3 N·m (27 lbf·in).
 - ☞ Position transmission cover (2).
 - ☞ Tighten housing screws (1) with a tightening torque of 1.5 N·m (13 lbf·in).
- The oil change is complete.

OIL CHANGE DATA

- ① The adjacent table is used for documenting oil changes on your Pinion bicycle transmission.
It is not essential to have oil changes performed by a specialist workshop, but they must be done proficiently so as to avoid the possibility of claims on the grounds of liability for material defects.

Transmission serial no.:		Purchase date:	
Oil change	Date / dealer stamp	Oil change	Date / dealer stamp
1		7	
2		8	
3		9	
4		10	
5		11	
6		12	

LEGAL INFORMATION

LIABILITY

The legal liability requirements apply for damage to material and workmanship. The liability period starts on the date of initial purchase.

This does not include components that are subject to normal wear (e.g. shift cable with outer sleeve).

Damage caused by improper use, unintended use or improper installation or maintenance (e.g. opening the transmission, modifications, etc.) is not included.

We also do not accept liability for immediate or consequential damages arising from negligence.

① In case of damage, first contact the dealer from which you purchased your Pinion product.

The dealer will contact the bicycle manufacturer, distributor or us directly to discuss the procedure on your behalf.

Do not return a defective Pinion product directly to us without prior consultation.

PINION.EU

MADE IN GERMANY
