

# Resilmount A50R-2

Resilient Isolation Hanger



Dashboard



## APPLICATION

Resilmount™ A50R-2 is specifically designed for the support and acoustical isolation of internal suspended ceiling systems.



## FEATURES

- Easily works with all hanger wire.
- Easy installation into new or existing ceiling systems.
- Acoustically tested for STC and IIC.
- Does not reduce the load capacity of the ceiling system.
- Suitably isolates the ceiling system from the structure to reduce structure and airborne noise.
- Load capacity: 120 Lbs.



## DYNAMIC CHARACTERISTICS

The Resilient A50R-2 will deflect 3/16" when loaded to 120lb capacity and maintain optimal sound isolation in accordance with US Standards.



## INSTALLATION NOTES

When selecting hangers, it is recommended that the calculated mass of the ceiling system is increased by 10-20% to avoid overloading of the isolation element. If maximum rated deflections are required, the ceiling system needs to be accurately weighed and point loads assessed in accordance with the architectural specifications of the project.

The site contractor can undertake normal installation procedures of the suspended ceiling system. Once the hanging wire has been hung from the substrate, the lower end of the wire needs to be bent up in accordance with the ceiling system manufacturers specifications, providing a 'hook' on which the Resilmount™ A50R-2 can be hung.

Once the mount is in place, another section of hanging wire is required to be bent and inserted through the lower side of the Resilmount™ A50R-2. The shaft of this wire then becomes the mounting point for the ceiling suspension clip.

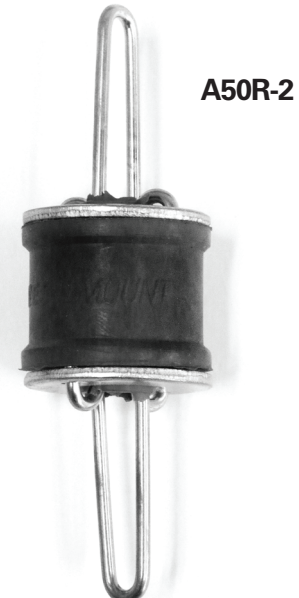

A50R-2

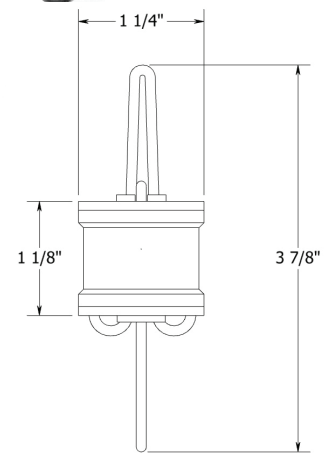
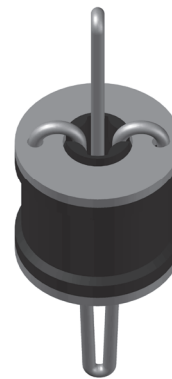

## SPECIFICATIONS

Code	Clip Height	Max Deflection*	Weight Capacity (lbs)*	Color
A50R-2	4"	3/16"	120	Black

\*Maximum Deflection at Maximum weight

# Lead time and minimum quantities may apply.

Datasheet

## RELATED PRODUCTS

- A237R Resilmount Sound Isolation Clip
- A237 Resilmount Clip without rubber
- A48R Resilmount Right angle bracket
- A24R Double Resilmount bracket

## WARRANTY

This product is covered by a year guarantee. Conditions and limitations of guarantees and warranties are set out in Studco Project Guarantee certificate.

## FURTHER ASSISTANCE

Contact the technical engineering team at Studco Technical Services for assistance with specifications, product selection, acoustic engineering and structural engineering enquiries.  
Tel: 800.675.8023 or email [sales@resilmount.com](mailto:sales@resilmount.com)

## ACCREDITATION/CERTIFICATION

