

HOIST®

**MULTI
STACK**





STATION 2

STATION 1

STATION 1 :: Rigid Arm Lat Pulldown :: Leg Press :: High Pulley

- :: Counter-balanced arm and self-aligning handles provide a smooth, natural feel to the lat pulldown.
- :: Angled thigh brace rollers on the lat pulldown allow you to quickly and easily slip into position without the need for adjustment.
- :: The self-aligning foot plate on the leg press station automatically adjusts during the exercise to follow the natural movement of your feet, taking the strain off of your ankles.
- :: The 2:1 Split Weight Cabling™ ratio on the leg press provides 400 pounds of exercise resistance.
- :: The high pulley station allows you to perform triceps pushdown exercises.

STATION 2 :: Chest Press :: Mid Row :: Leg Extension :: Standing Leg Curl

- :: Interchangeable press arm options allow you to pick the one that's right for you! Choose between the traditional fixed press arm with patented range of motion or the patented 3-D articulating press arm.
- :: Low and mid pulley stations allow you to perform a variety of upper and lower body exercises.
- :: Dual adjusters on the back pad offer both telescoping and angular adjustments to provide proper positioning and back support.
- :: Locking pull pin provides stable pad positioning.

H2200

DIMENSIONS

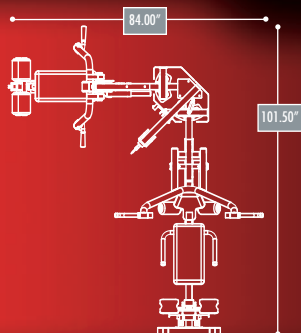

Length ::	101.50"
Width ::	84.00"
Height ::	82.25"

**SPACE SAVING,
L-SHAPED DESIGN
FITS INTO
ANY CORNER!**

FRONT VIEW OF H-2200 STATION 1
with Patented Rigid Arm Lat Pulldown



FRONT VIEW OF H-2200 STATION 2
with Patented 3-D Articulating Handle





STATION 1 :: Leg Press

- :: Pillow block bearings and a 4-bar linkage system provide smoother motion and increased durability.
- :: The foot plate follows the natural movement of your feet, taking the strain off of your ankles.
- :: The adjustable back pad accommodates different sized users and allows for pre-stretch adjustments.
- :: The 2:1 Split Weight Cabling™ ratio provides 400 pounds of exercise resistance.

STATION 2 :: Adjustable Cable Column

- :: Pulley adjusts to 23 different positions.
- :: Split Weight Cabling™ reduces resistance by 50% to accommodate a greater number of exercises.

STATION 3 :: Rigid Arm Lat Pulldown

- :: Counter-balanced arm with self-aligning handles automatically accommodates the movement and size of individual users.
- :: Angled thigh brace rollers eliminate the need for adjustments.

STATION 4 :: Chest Press :: Mid Row :: Leg Extension :: Standing Leg Curl

- :: The patented ROM adjustment allows you to adjust your starting position on the fixed press arm.
- :: The patented 3-D articulating press arm allows you to control both the arc and angle of the exercise path.



H4400

FRONT VIEW OF H-4400 STATION 3
with Patented Rigid Arm Lat Pulldown



FRONT VIEW OF H-4400 STATION 4
with Patented 3-D Articulating Handle



DIMENSIONS

Length :: 103.00"
Width :: 95.00"
Height :: 83.50"

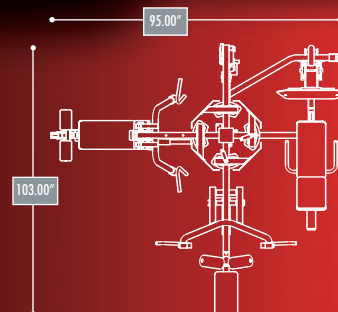

ACCOMMODATES
UP TO 4 USERS
AT ONE TIME!

- A** :: Patented Radial Loc® Weight System with 2½ lb. incremental weights and weight pin lanyard. This interlocking weight system provides for a tighter fit and less shifting between plates.
- B** :: Patented Rigid Arm Lat Pulldown has wide-open head clearance for safety. Self-Aligning Handles automatically adjust throughout the exercise movement to accommodate users of all sizes.
- C** :: Patented 3-D Articulating Press Arm allows you to control both the arc and angle of the exercise path.
- D** :: Patented Range of Motion Adjustment customizes your starting position on bench press, shoulder press, incline press and mid-row exercises.
- E** :: Dual Adjusting Back Pad provides proper body positioning, and our Easy Glide™ inserts eliminate metal-to-metal wear and friction.
- F** :: Leg Extension/Leg Curl station has an integrated cam to prevent resistance drop off at the end of the exercise. Patented, Self-Aligning Rollers adjust automatically and provide thigh support.

STANDARD



Visit us on the web at
hoistfitness.com

FEATURES

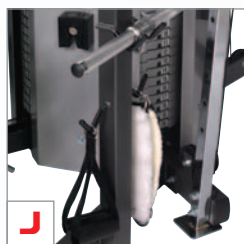

SPECIFIC

H2200

- G** :: Accessory Rack is built-in to keep straps and exercise bars conveniently within your reach.
- H** :: Self-Aligning Foot Plate on the leg press station pivots to follow your natural exercise motion. Non-skid surface assures secure foot placement.
- I** :: Contoured Seats and Back Pads add comfort and lumbar support. Angled Thigh Brace Rollers provide secure positioning for lat pulldown exercises.

H4400

- J** :: Accessory Rack provides neat storage of straps and exercise bars while not in use.
- K** :: Foot Plate with Dual-Pivot Linkage Control is ergonomically designed to reduce joint stress. Oversized foot plate with non-skid surface accommodates users of all sizes.
- L** :: High-Low Pulley with Adjustable Cable Column has 23 selectable positions for increased versatility.



800.548.LIFT sales@hoistfitness.com

9990 Empire Street
San Diego, CA 92126