

FRAMES & SUSPENSION

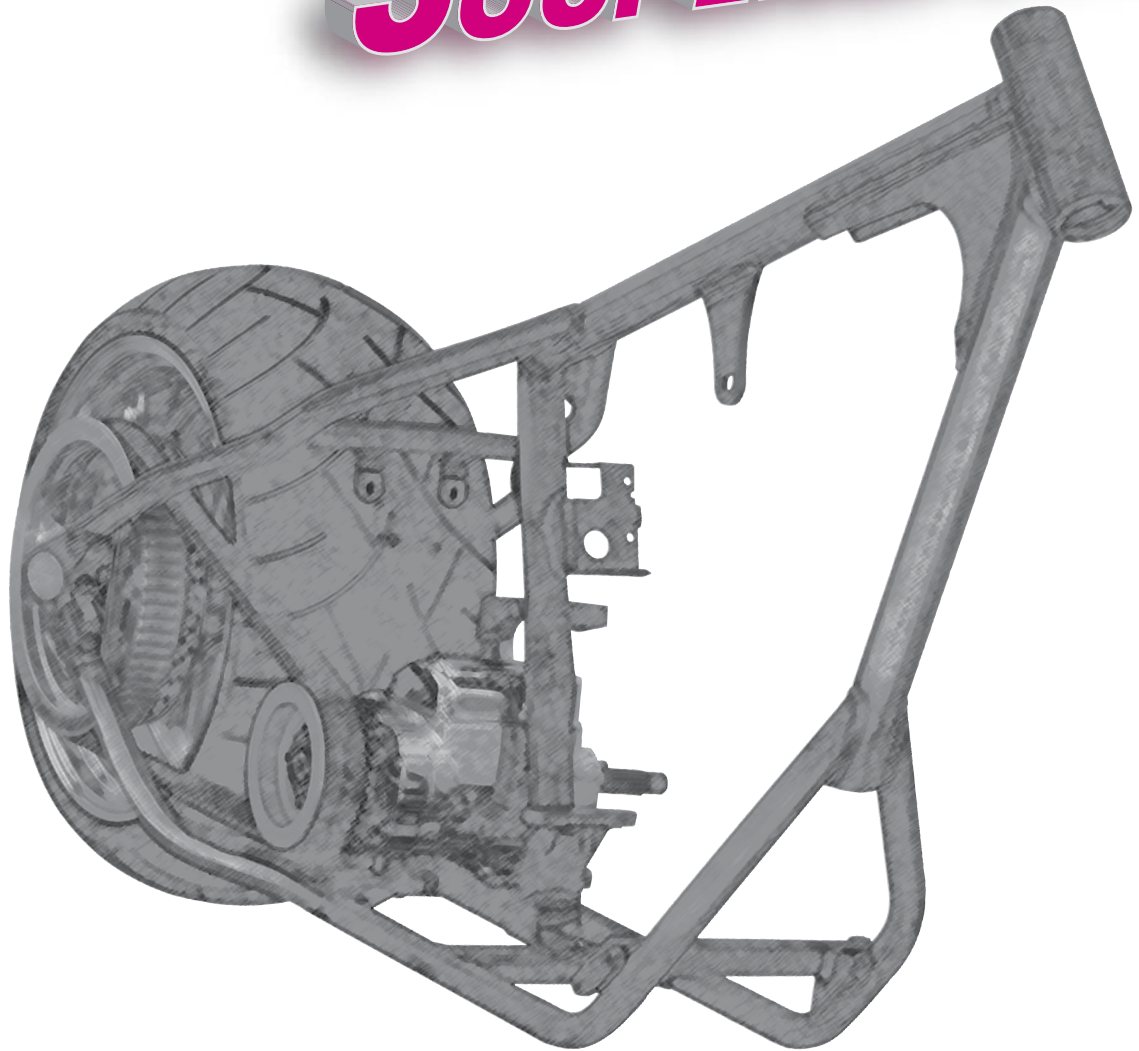

45" FRAMES _____	80-81
BOARDTRACK FRAMES _____	79
CAPTAIN AMERICA PARTS _____	104-105
DYNA FRAMES _____	74
FRAMES FOR BIG TWINS _____	73-93
FRAMES FOR SPORTSTERS _____	99-102
FXR FRAMES _____	75
SWINGARMS _____	75, 77, 84, 94-97
TRIKE FRAMES _____	73



PAUGHCO FRAMES

*** IMPORTANT NOTES ***

Due to an extremely large selection and wide variations in frame options, Paughco frames are built to order. Please order carefully, as a cancellation or a change after a 48-hour period could result in a 20% restocking fee.

We will need the following information when ordering frames:

- Early or late-style Fat Bob tank mounts
- Year and type of engine
- Type of rear brakes
- Type of transmission

Paughco frames have many stock-type options. However, they are not exact replicas.

Paughco offers swingarm frames in two popular styles; 1958-1964 and 1965-1986. They will not accept seat post bushings and pogo seats. These are not stock replacement frames, although they are offered with many stock-type options.

Paughco also offers custom rubber mount swingarm frames, utilizing FXR or FLT transmissions. They come in different variations of stretch and rake, to fit your choice of engines.

WE RECOMMEND PRE-FITTING PARTS BEFORE PAINTING. PAUGHCO FRAMES ARE NOT STOCK REPLACEMENT FRAMES.

To achieve a level ride height when using a 21" front and a 16" rear wheel with a Paughco Springer or stock triple trees, please use the table below to determine the front end length. When using Paughco raked triple trees, please call our sales staff TOLL FREE at 800-423-2621 to determine the correct length.

Due to other factors such as variations in rim size and tire sidewall height, all lengths listed below are approximate.

SPRINGERS ARE NOT RECOMMENDED FOR USE WITH RAKES OVER 40°

SPRINGER FRONT ENDS		Degrees of Rake			
		30°	35°	40°	45°
Stretch in Downtubes (UP)	0"	Stock Length	3" Over	6" Over	Not Recommended
	2" to 2¼"	3" Over	6" Over	9" Over	Not Recommended
	4"	6" Over	9" Over	12" Over	Not Recommended
	6"	9" Over	12" Over	15" Over	Not Recommended
	8"	12" Over	15" Over	18" Over	Not Recommended
	10"	15" Over	18" Over	21" Over	Not Recommended
FH139/FHR139 Frames For 45's		2" Under	Stock Length	3" Over	Not Recommended
RS147FLT Road King Frame		Not Applicable	Not Applicable	Not Applicable	Not Applicable

WIDE GLIDE FORKS*		Degrees of Rake			
		30°	35°	40°	45°
Stretch in Downtubes (UP)	0"	4" Under	2" Under	Stock Length	2" Over
	2" to 2¼"	2" Under	Stock Length	2" Over	4" Over
	4"	2" Over	4" Over	6" Over	8" Over
	6"	4" Over	6" Over	8" Over	12" Over
	8"	6" Over	8" Over	12" Over	14" Over
	10"	8" Over	10" Over	14" Over	18" Over

* WIDE GLIDE FORK LENGTHS ARE BASED ON A STOCK FXWG OR FX SOFTAIL FORK. WHEN INSTALLING 4-SPEED FLH FORKS, ADD 4" TO THE MEASUREMENTS SHOWN ABOVE (EXAMPLES: USE STOCK LENGTH FORK TUBES ON FRAMES WITH A 30° RAKE AND NO STRETCH IN THE DOWNTUBES, OR USE 8" OVER FORK TUBES ON FRAMES WITH A 35° RAKE AND 4" STRETCH IN THE DOWNTUBES).



RIGID TRIKE FRAMES



PAUGHCO RIGID TRIKE FRAMES

These rigid trike frames feature a 1½"-diameter backbone with 1⅛"-diameter frame rails and downtubes. They're available in 4-speed and 5-speed versions with your choice of straight leg or wishbone front downtubes. The 5-speed frames use 1986–1999 Softail oil tanks and the 4-speed frames use early-style 4-speed oil tanks. They do not include gas tank mounts, so you're free to express your creativity.... pick a custom tank from our huge selection, or make your own. These frames accept Paughco's US-made axle assemblies.



STRAIGHT LEG AND WISHBONE TRIKE FRAMES FOR 1936-1999 BIG TWIN ENGINES

4-SPEED TRANSMISSION		SOFTAIL 5-SPEED TRANSMISSION				
STRAIGHT LEG	WISHBONE	STRAIGHT LEG	WISHBONE	OUT	UP	RAKE
TKS139	TKS128	TKS139S5	TKS128S5	0"	0"	30°
TKS139A	TKS128A	TKS139S5A	TKS128S5A	0"	0"	35°
TKS139B	TKS128B	TKS139S5B	TKS128S5B	0"	0"	40°

TO ORDER THESE PARTS, CALL US AT 775-246-5738
OR TOLL FREE AT 800-423-2621



TRIKE
KITS

SPRINGERS
& FORKS

HANDLEBARS
& RISERS

LIGHTING

FRAMES &
ACCESSORIES

WHEELS
& BRAKES

GAS & OIL
TANKS

SHEET
METAL

ENGINE &
ELECTRICAL

PRIMARY &
DRIVETRAIN

FOOT
CONTROLS

TRANSMISSION

EXHAUST

TOOLS &
GENERAL

CUSTOM DYNA FRAMES



D147EWG
Stock-Style Frame For
1996-2005 Model
Drivelines Shown



D147E
Stock-Style Frame For
1996-2005 Model
Drivelines Shown

D147L
Stock-Style Frame
For 2006-2017 Model
Drivelines Shown



STOCK-STYLE FRAMES FOR 1996-UP DYNA MODELS

These new Dyna frames are offered in early- and late-style configurations. The early version uses 1996-2005 5-speed Evolution and Twin Cam drivelines in conjunction with 130-series rear tires and 1½" or 1⅞"-wide rear belts. The later version uses 2006-up 6-speed Twin Cam drivelines for 200-series rear tires and 1⅞" or 1"-wide rear belts. They also offer both standard Dyna and Dyna Wide Glide neck angles. These frames feature a round DOM 1¾"-diameter, 3/16"-thick wall backbone with a custom steering neck unlike the square backbone and unsightly box neck of the stock frames. The steering neck does not have provisions for a fork lock, but the backbone has a machined slot under the front to allow stock wiring to be pulled thru it,

just like stock frames. The downtubes and frame rails are 1¼"-diameter, .120"-thick wall DOM tubing. Each frame includes the stock fuel tank mounts as well as mounts for the stock regulator, kickstand, oil tank, battery tray, electrical panel, motor mounts, mid and forward control mounts, and the rear brake reservoir. The fender struts are made from 1/2"-thick steel plate and will accept stock fenders and shock bolts. The stock OEM swingarms and components will work with these frames, which are great for a crash repair, or building a new ground-up custom.

FRAMES FOR 1996-2005 DYNA MODELS

D147E For FXD models except FXDWG/FXDL (28° neck)

D147EWG For FXDWG/FXDL models (32° neck)

FRAMES FOR 2006-2017 DYNA MODELS

D147L For FXD models except FXDWG/FXDL (29° neck)

D147LWG For FXDWG/FXDL models (34° neck)



STOCK REPLACEMENT & CUSTOM FXR FRAMES

PAUGHCO STOCK-STYLE AND CUSTOM FXR FRAMES

These all-new FXR-style frames are an easy way to build a cool looking custom with the great handling the original FXR's were famous for. They're available in stock and 180/200 tire versions that will accept a variety of drivelines. The backbones are made from 1 3/4" O.D. steel tubing with .250" wall thickness, and the frame rails are made from 1 1/4"-diameter tubing. The stock-width frames will accept a 130-series tire with a 1 1/2"-wide belt. The wide frames accept 180-series tires with a 1 1/2"-wide belt, or 200-series tires with a 1 7/8"-wide belt or a chain. The stock-width frames will accept OEM or Paughco standard-width swingarms, while the wide tire frames require a custom Paughco swingarm and a 9"-wide fender (sold separately). The swingarm, pivot blocks and shaft, are not included but are available separately.



R147FXRTDW
Wide Custom Frame
For Touring Model
Drivelines Shown



CUSTOM FXR-STYLE FRAMES FOR TOURING MODEL DRIVELINES

These custom frames are designed to accept all 1993–2011 Evolution or Twin Cam Touring model drivelines with the oil tank located under the transmission. They include FXR-style mounts for the gas tank, side covers, seat and battery. They also include a special sheetmetal plate that covers the area where the oil tank would normally reside. These frames are configured for forward controls and have a three-point mount on the left-side that will accept a forward shifter bracket and conventional kickstand mounting bracket.

R147FXRTD Stock-style FXR frame for Touring driveline ONLY

R147FXRTDW Wide custom FXR frame for Touring driveline ONLY



R147FXRTDW
Wide Custom Frame

STOCK-STYLE FXR FRAMES

These replacement frames for FXR models accept all 1982–2000 Shovelhead and Evolution FXR drivelines, as well as 1980–1992 Touring model drivelines (no oil pan under the transmission). All of the stock mounts for the gas and oil tanks, seat, battery, kickstand and side panels are already installed.

R147FXR Stock-style FXR frame ONLY

R147FXRW Wide custom FXR frame ONLY

SWINGARMS AND AXLES

Use these components with the Stock-Style or Custom FXR frames on this page.

153R Stock swingarm – raw steel

153RC Stock swingarm – chrome

153FXRW Wide swingarm – raw steel

153FXRCW Wide swingarm – chrome

25AK Axle kit for 153R and 153RC swingarms

25FXRWK Axle kit for 153FXRW and 153FXRCW swingarms



153FXRW



25FXRWK

TO ORDER THESE PARTS, CALL US AT 775-246-5738
OR TOLL FREE AT 800-423-2621



TRIKE
KITS

SPRINGERS
& FORKS

HANDLEBARS
& RISERS

LIGHTING

FRAMES &
ACCESSORIES

WHEELS
& BRAKES

GAS & OIL
TANKS

SHEET
METAL

ENGINE &
ELECTRICAL

PRIMARY &
DRIVETRAIN

FOOT
CONTROLS

TRANSMISSION

EXHAUST

TOOLS &
GENERAL

MOUNTS FOR RUBBER-MOUNT ENGINES



HEAVY-DUTY 5-SPEED FRONT MOTOR MOUNT

Made from heavy-duty polyurethane, this mount helps reduce vibration in the drivetrain. Kit includes chrome mounting block, and a two-piece bushing with internal spacer tube.

741FXRBF Fits all FXR and Touring models from 1980 thru 2009



R154S

741FXRBR

5-SPEED SWINGARM PIVOT SHAFT AND ISOLATOR BUSHINGS

Rebuild your swingarm with these key parts. Perfect reproductions of the originals. Sold each.

741FXRBR Isolator mount for 1980-up Touring and FXR models (2 required) OEM 47564-86B

R154S Pivot shaft for 1980-2001 Touring and FXR models (OEM 47492-89A)

741XLBF



741XLBR



RUBBER MOTOR MOUNT BUSHINGS FOR 2004-UP SPORTSTERS

Perfect reproductions of the factory rubber mounts. Sold each.

741XLBF Front mount (OEM 48463-04)

741XLBR Rear mount (OEM 48492-04)



5-SPEED SWINGARM 'UPGRADE' KIT

Specially-designed to upgrade the quality and feel of the driveline on your FXR or Touring model bike. These 7-piece kits convert the old-style Original Equipment parts to high-tech spherical bearings with CNC-machined precision spacers and collars.

R154KT Fits all FXR and Touring models from 1980 thru 2001



SWINGARM PIVOT BLOCKS

Precision CNC-machined from billet 6061 aluminum, these swingarm pivot blocks are available in chrome or black powder paint. They fit all FXR models from 1982 thru 2000, as well as many custom Paughco rubber mount applications. Sold in pairs.

R154PBC Chrome

R154PBB Black



CUSTOM RUBBER-MOUNT FRAMES



SWINGARM FRAME FOR ROAD KINGS

Stock style 1994–2006 frame with 26° rake. Accepts Twin Cam 88 and Evolution engines with matching Touring model transmissions. Accepts all stock sheet metal, forks and suspension.

RS147FLT Frame ONLY

STOCK-STYLE RAW STEEL REAR SWINGARMS AND AXLE

These swingarms and axle fit all 5-speed rubbermounted Touring models from 1993 thru 2001.

153FLT-1 Fits 1993–1999 models (except 1996 models) with 3/4"-diameter axles ONLY

153FLT Fits 2000–2001 models with 3/4"-diameter axles ONLY

25AK 3/4"-diameter axle kit for 153FLT-1 and 153FLT swingarms



LATE TOURING MODEL FRAMES FOR RUBBER-MOUNT DRIVETRAINS

These frames are set up for the following components that must be purchased separately:

- FXWG or FXST front ends
- Engine and transmission for Touring models
- 1997–up Touring model snap-on side covers
- 1997–up Touring model fenders and saddlebags
- 1997–up stock guard rails and highway bars
- 1998 Road King gas tank and seat
- 1999–up forward controls for Touring models

LATE TOURING MODEL FRAMES FOR RUBBER-MOUNT DRIVETRAINS							
WITH ROAD KING TANK MOUNTS				WITHOUT ROAD KING TANK MOUNTS			
	OUT	UP	RAKE		OUT	UP	RAKE
R147FLT	0"	0"	30°	R145FLT	0"	0"	30°
R147AFLT	0"	0"	35°	R145AFLT	0"	0"	35°
R147BFLT	0"	0"	40°	R145BFLT	0"	0"	40°

**TO ORDER THESE PARTS, CALL US AT 775-246-5738
OR TOLL FREE AT 800-423-2621**



TRIKE KITS
SPRINGERS & FORKS
HANDLEBARS & RISERS
LIGHTING
FRAMES & ACCESSORIES
WHEELS & BRAKES
GAS & OIL TANKS
SHEET METAL
ENGINE & ELECTRICAL
PRIMARY & DRIVETRAIN
FOOT CONTROLS
TRANSMISSION
EXHAUST
TOOLS & GENERAL

RIGID SINGLE LOOP BIG TWIN FRAMES



SPECIAL NOTES:

1) KNUCKLEHEAD OR PANHEAD ENGINES WILL NEED TO HAVE A SMALL DENT MADE IN THE FRONT EXHAUST PIPE TO CLEAR THE FRONT FRAME DOWNTUBE.



PAUGHCO SINGLE LOOP RIGID FRAMES FOR 1936-1999 BIG TWIN ENGINES

Another cool new frame design from Paughco that you can install a Knucklehead, Panhead, Shovelhead or Evolution engine in. These frames feature a distinctive 1½"-diameter single loop front downtube with an additional 2" in the backbone and 1½"-diameter frame rails. They're offered in 4-speed and 5-speed versions that come without gas tank mounts, so you can choose any custom tank that fits your style. These frames build stylish small and low "Bobbers" as well as long, lean "Choppers." You pick the size and style and Paughco will custom build it just for your tastes.

SINGLE LOOP RIGID BOBBER FRAMES FOR 1936-1999 BIG TWIN ENGINES

4-SPEED TRANSMISSION WITH BELT OR CHAIN	SOFTTAIL-STYLE 5-SPEED TRANSMISSION WITH BELT	OUT	UP	RAKE
SLP139	SLP139S5	2"	0"	30°
SLP140-44	SLP140S5-44	4"	4"	30°
SLP139A	SLP139S5A	2"	0"	35°
SLP140-44A	SLP140S5-44A	4"	4"	35°
SLP139B	SLP139S5B	2"	0"	40°
SLP140-44B	SLP140S5-44B	4"	4"	40°



'BOARDTRACK' RIGID FRAMES FOR BIG TWINS



139S5-USP



PAUGHCO 'BOARDTRACK' FRAMES By US CHOPPERS

These frames were originally designed by US Choppers for their unique 'Boardtrack Platform' project. The single cradle design and low-slung weight permits incredible lean angles. And having the motor weight pushed forward, enables aggressive riding into corners, while the centered drivetrain gives perfect balance and lean symmetry. These frames will accommodate any pre-Twin Cam Harley-style engine up to 124 cubic inches including Indian PowerPlus engines, and rear tires from 160x16" to 90/90x21". There are two versions available.... one with a curved backbone that requires a custom curved gas tank, and one with a straight backbone that is intended for use with our new Paughco 1915-style tank.

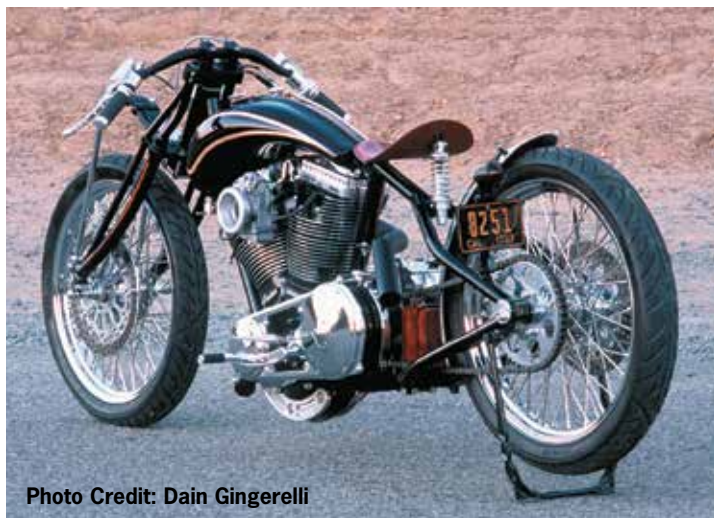

Photo Credit: Dain Gingerelli

- 139S5-USP** Curved backbone frame
- 128S5-USP** Straight backbone frame
- 1915ST** Gas tank for #128S5-USP
- 218BM** Billet aluminum under-engine boomerang for single loop cradle (set)



128S5-USP



1915ST
3.5 GALLON TANK
FOR 128S5-USP
BOARDTRACK
FRAME



TO ORDER THESE PARTS, CALL US AT 775-246-5738
OR TOLL FREE AT 800-423-2621



TRIKE
KITS

SPRINGERS
& FORKS

HANDLEBARS
& RISERS

LIGHTING

FRAMES &
ACCESSORIES

WHEELS
& BRAKES

GAS & OIL
TANKS

SHEET
METAL

ENGINE &
ELECTRICAL

PRIMARY &
DRIVETRAIN

FOOT
CONTROLS

TRANSMISSION

EXHAUST

TOOLS &
GENERAL

MAGNUM MOTOR FRAMES



"MAGNUM MOTOR" 45" RIGID FRAMES

Now available exclusively from Paughco, these frames were specially-designed to work with the legendary "Magnum Motors" first built in the late 60's. These motors feature a 45" lower end with a 900cc Sportster top end, and they not only looked cool, but they ran as good as they looked.

Paughco's new Magnum Motor frames have all of the same features of our standard 45" frames with single front downtube styling, and the ability to use a 1941-1969 4-speed Big Twin transmission. All of the available accessories for our 'Project 45' frames (except the exhaust systems – call for more information) will work with both frames. Available in all the popular rakes and stretches. See chart to the right for frame part numbers.

ACCESSORIES FOR MAGNUM MOTORS FRAMES

218FH	Transmission mounting plate
FHCB200	Optional forward control mounting block
748FH	Wrap-around style oil tank
748RDFH	Round style oil tank
728A	Upswept Fishtail drag pipe set
728B	Drag pipe set
26BK	3/4"-dia. axle kit for disc brake wheels
45SPK20	20-tooth custom engine sprocket
45SPK22	22-tooth custom engine sprocket
45SPK24	24-tooth custom engine sprocket
45BDL	Complete BDL belt drive kit

FRAMES FOR 900CC MAGNUM ENGINES AND 1941-1969 4-SPEED TRANSMISSIONS

FOR ROUND OIL TANK	FOR WRAP-AROUND OIL TANK	OUT	UP	RAKE
FHMR139	FHM139	0"	0"	30°
FHMR139-24	FHM139-24	2"	4"	30°
FHMR139-36	FHM139-36	3"	6"	30°
FHMR139A	FHM139A	0"	0"	35°
FHMR139-24A	FHM139-24A	2"	4"	35°
FHMR139-36A	FHM139-36A	3"	6"	35°
FHMR139B	FHM139B	0"	0"	40°
FHMR139-24B	FHM139-24B	2"	4"	40°
FHMR139-36B	FHM139-36B	3"	6"	40°



RIGID FRAMES FOR 45's

TRIKE
KITS

SPRINGERS
& FORKS

HANDLEBARS
& RISERS

LIGHTING

FRAMES &
ACCESSORIES

WHEELS
& BRAKES

GAS & OIL
TANKS

SHEET
METAL

ENGINE &
ELECTRICAL

PRIMARY &
DRIVETRAIN

FOOT
CONTROLS

TRANSMISSION

EXHAUST

TOOLS &
GENERAL



'PROJECT 45' FRAMES FOR 1941-1969 4-SPEED TRANSMISSION ASSEMBLIES

FOR ROUND OIL TANK	FOR WRAP-AROUND OIL TANK	OUT	UP	RAKE
FHR139	FH139	0"	0"	30°
FHR139-24	FH139-24	2"	4"	30°
FHR139-36	FH139-36	3"	6"	30°
FHR139A	FH139A	0"	0"	35°
FHR139-24A	FH139-24A	2"	4"	35°
FHR139-36A	FH139-36A	3"	6"	35°
FHR139B	FH139B	0"	0"	40°
FHR139-24B	FH139-24B	2"	4"	40°
FHR139-36B	FH139-36B	3"	6"	40°

'PROJECT 45' FRAMES AND ACCESSORIES

The 45" flathead engine was made for 37 years, and was simple and efficient, if not particularly powerful.... but the real weak link in the powertrain was its three-speed transmission. These single downtube rigid frames address that issue, by using a four-speed transmission instead of the old three-speed unit. We designed a special engine sprocket for Big Twin dual row primary chains and positioned the transmission mounts so that the primary drive components and special Paughco covers from an early 74" Big Twin can be fitted to the bike. And for those who don't want to deal with a wet clutch, we have a BDL belt drive unit instead.

FRAMES FOR 1937-1973 FLATHEAD 45" ENGINES

These highly-popular single-loop frames are designed to house a 1941 thru 1969 4-speed transmission with chain or belt final drive. Our custom billet aluminum transmission mounting plate must be purchased separately, as well as the axle kit. An optional weld-on mounting block for forward controls is also sold separately. See chart at left for frame part numbers.

- 26BK** 3/4"-dia. axle kit for disc brake wheels
- 218FH** Aluminum transmission mounting plate
- FHCB200** Optional forward control mounting block

OIL TANKS FOR 'PROJECT 45' FRAMES

These 3 quart oil tanks are available in two cool styles.... an old school wrap-around, and a round-style with battery tray.

- 748FH** Wrap-around style
- 748RDFH** Round style

1 3/4" EXHAUST SYSTEMS FOR 'PROJECT 45' FRAMES

These pipes are stepped out from 1 1/2" to 1 3/4" and bolt to the 4-speed transmission end cover on the new frames.

- 728A** Upswept Fishtails
- 728B** Drag pipes

ENGINE SPROCKETS FOR 'PROJECT 45' FRAMES

These sprockets convert 45" engines to use a Big Twin double-row primary chain with our 'Project 45' frames. Install a 4-speed Big Twin transmission into the frame using the included mounting plate.... aligns perfectly with 1936-1964 OEM mainshafts.

- 45SPK20** 20-tooth
- 45SPK22** 22-tooth
- 45SPK24** 24-tooth

BDL OPEN BELT DRIVE KIT FOR 'PROJECT 45' FRAMES

A 1 1/2"-wide open belt drive kit for 45" motors installed in our frame. The front pulley has the correct taper for the 45" engine shaft, and the rear clutch assembly is a Big Twin 4-speed style.

- 45BDL** Complete kit



**TO ORDER THESE PARTS, CALL US AT 775-246-5738
OR TOLL FREE AT 800-423-2621**



TRIKE
KITS

SPRINGERS
& FORKS

HANDLEBARS
& RISERS

LIGHTING

FRAMES &
ACCESSORIES

WHEELS
& BRAKES

GAS & OIL
TANKS

SHEET
METAL

ENGINE &
ELECTRICAL

PRIMARY &
DRIVETRAIN

FOOT
CONTROLS

TRANSMISSION

EXHAUST

TOOLS &
GENERAL

STRAIGHT LEG & WISHBONE SWINGARM FRAMES

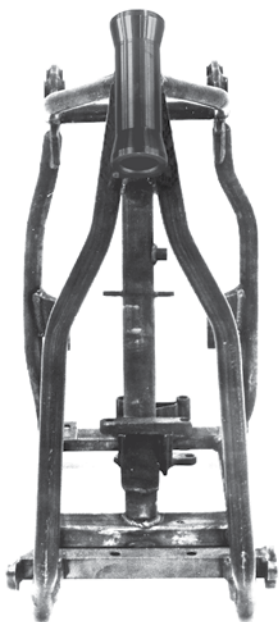

S151



145A

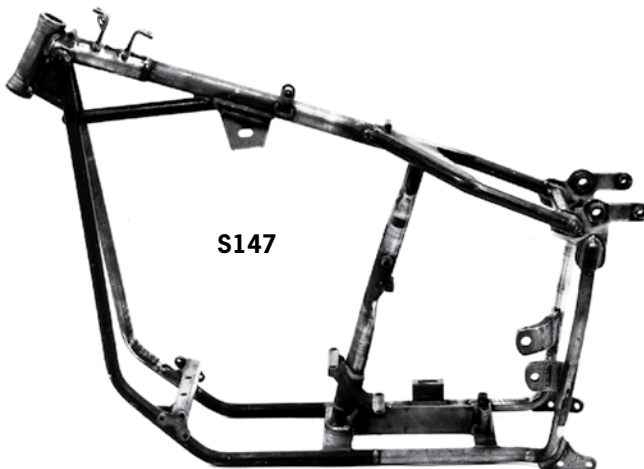

S147



S144-5A
USES FXR OR TOURING
MODEL TRANSMISSION



S149



STRAIGHT LEG & WISHBONE SWINGARM FRAMES

STRAIGHT LEG AND WISHBONE SWINGARM FRAMES

These frames are similar to those of the 1970's and 1980's 4-speed models. They can be combined with a variety of drivetrains, including Shovelhead and Evolution engines used in conjunction with 4-speed transmissions, 5-speed Softail transmissions, and even the 5-speed transmissions from FXR and Touring models. Straight Leg and the timeless Wishbone frame styles are available with a variety of options and rake/stretch configurations. You can choose from OEM or Chopper-style necks, with or without tank mounts for pre-1984 Fat Bob gas tanks.

Refer To Instructions On Page 72 Before Ordering.

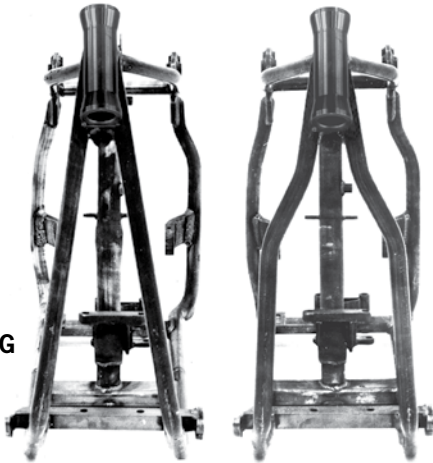

STRAIGHT LEG FRAME

WISHBONE FRAME

SPECIAL NOTES:
 1) STOCK-STYLE FXR OR TOURING MODEL SWINGARMS WILL NOT WORK WITH THESE FRAMES
 2) FRAMES FOR 5-SPEED SOFTAIL TRANSMISSIONS INCLUDE A PAUGHCO #218A TRANSMISSION MOUNTING PLATE

CALL FOR PRICES

STRAIGHT LEG SWINGARM FRAMES				WISHBONE SWINGARM FRAMES				OUT	UP	RAKE
OEM STYLE NECK		CHOPPER STYLE NECK		OEM STYLE NECK		CHOPPER STYLE NECK				
WITH FAT BOB MOUNTS	WITHOUT FAT BOB MOUNTS	WITH FAT BOB MOUNTS	WITHOUT FAT BOB MOUNTS	WITH FAT BOB MOUNTS	WITHOUT FAT BOB MOUNTS	WITH FAT BOB MOUNTS	WITHOUT FAT BOB MOUNTS			
4-SPEED TRANSMISSION WITH CHAIN OR BELT FINAL DRIVE										
\$147	\$145	147	145	\$151	\$149	151	149	0"	0"	30°
\$146B	\$144B	146B	144B	\$150B	\$148B	150B	148B	0"	2¼"	30°
\$147A	\$145A	147A	145A	\$151A	\$149A	151A	149A	0"	0"	35°
\$146A	\$144A	146A	144A	\$150A	\$148A	150A	148A	0"	2¼"	35°
\$147B	\$145B	147B	145B	\$151B	\$149B	151B	149B	0"	0"	40°
\$146	\$144	146	144	\$150	\$148	150	148	0"	2¼"	40°
FXR OR TOURING 5-SPEED TRANSMISSION WITH CHAIN OR BELT FINAL DRIVE										
\$147-5	\$145-5	147-5	145-5	\$151-5	\$149-5	151-5	149-5	0"	0"	30°
\$146-5B	\$144-5B	146-5B	144-5B	\$150-5B	\$148-5B	150-5B	148-5B	0"	2¼"	30°
\$147-5A	\$145-5A	147-5A	145-5A	\$151-5A	\$149-5A	151-5A	149-5A	0"	0"	35°
\$146-5A	\$144-5A	146-5A	144-5A	\$150-5A	\$148-5A	150-5A	148-5A	0"	2¼"	35°
\$147-5B	\$145-5B	147-5B	145-5B	\$151-5B	\$149-5B	151-5B	149-5B	0"	0"	40°
\$146-5	\$144-5	146-5	144-5	\$150-5	\$148-5	150-5	148-5	0"	2¼"	40°
SOFTAIL 5-SPEED TRANSMISSION WITH BELT FINAL DRIVE										
\$147S5	\$145S5	147S5	145S5	\$151S5	\$149S5	151S5	149S5	0"	0"	30°
\$146S5B	\$144S5B	146S5B	144S5B	\$150S5B	\$148S5B	150S5B	148S5B	0"	2¼"	30°
\$147S5A	\$145S5A	147S5A	145S5A	\$151S5A	\$149S5A	151S5A	149S5A	0"	0"	35°
\$146S5A	\$144S5A	146S5A	144S5A	\$150S5A	\$148S5A	150S5A	148S5A	0"	2¼"	35°
\$147S5B	\$145S5B	147S5B	145S5B	\$151S5B	\$149S5B	151S5B	149S5B	0"	0"	40°
\$146S5	\$144S5	146S5	144S5	\$150S5	\$148S5	150S5	148S5	0"	2¼"	40°

**TO ORDER THESE PARTS, CALL US AT 775-246-5738
OR TOLL FREE AT 800-423-2621**



TRIKE KITS

SPRINGERS & FORKS

HANDLEBARS & RISERS

LIGHTING

FRAMES & ACCESSORIES

WHEELS & BRAKES

GAS & OIL TANKS

SHEET METAL

ENGINE & ELECTRICAL

PRIMARY & DRIVETRAIN

FOOT CONTROLS

TRANSMISSION

EXHAUST

TOOLS & GENERAL

STOCK-STYLE SWINGARM FRAMES & SWINGARMS



STOCK-STYLE SWINGARM FRAMES FOR 1965-1984 FL MODELS

These frames closely follow the dimensions of those found on 4-speed FL models from 1965-1984. They accept OEM or aftermarket oil tanks and battery boxes, and can be used with chain or belt final drive 4-speed transmissions. They're available with OEM or Chopper style necks, and with or without tank mounts for pre-1984 Fat Bob gas tanks or 1986-1999 'flatside' Softail gas tanks.

Refer To Instructions On Page 72 Before Ordering.

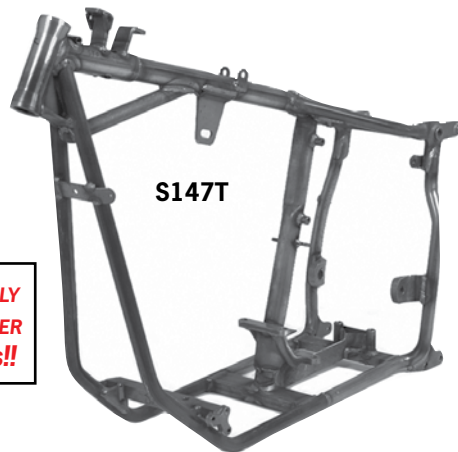

CHECK OUT THE UNBELIEVABLY LOW PRICES ON OUR CHOPPER NECK STRAIGHT LEG FRAMES!!

STRAIGHT LEG FRAMES				WISHBONE FRAMES				OUT	UP	RAKE
OEM STYLE NECK		CHOPPER STYLE NECK		OEM STYLE NECK		CHOPPER STYLE NECK				
WITH FAT BOB MOUNTS	WITHOUT FAT BOB MOUNTS	WITH FAT BOB MOUNTS	WITHOUT FAT BOB MOUNTS	WITH FAT BOB MOUNTS	WITHOUT FAT BOB MOUNTS	WITH FAT BOB MOUNTS	WITHOUT FAT BOB MOUNTS			
S147T	S145T	147T	145T	S151T	S149T	151T	149T	0"	0"	30°
S147AT	S145AT	147AT	145AT	S151AT	S149AT	151AT	149AT	0"	0"	35°
S147BT	S145BT	147BT	145BT	S151BT	S149BT	151BT	149BT	0"	0"	40°

SPECIAL NOTES:

- 1) ALL SWINGARMS ON THIS PAGE COME CHROMED, BUT MAY BE ORDERED WITH A RAW STEEL FINISH.
- 2) THESE SWINGARMS HAVE THE BEARING RACES ALREADY INSTALLED.

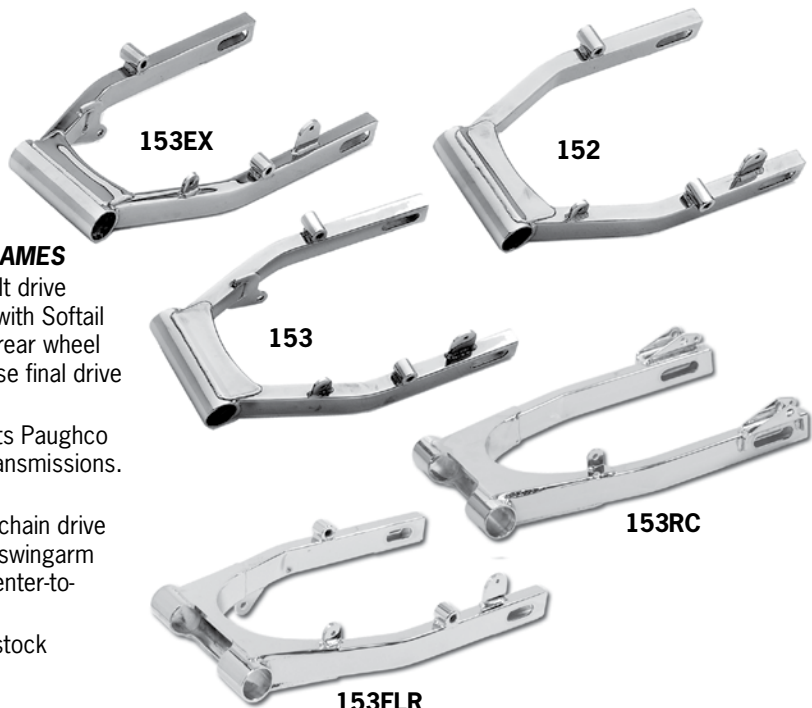

STOCK REPLACEMENT AND CUSTOM SWINGARMS FOR HD AND PAUGHCO FRAMES

- 153EX** 2" extended swingarm for all 4-speed belt drive frames, and Paughco swingarm frames with Softail 5-speed transmissions. Permits smaller rear wheel pulley to be run with stock belt to increase final drive ratio. 17¾" center-to-center
- 153** Fits all 4-speed belt drive frames. Also fits Paughco swingarm frames with Softail 5-speed transmissions. 15¾" center-to-center (OEM 47446-79)
- 152** Replacement swingarm for 1972-1983 chain drive 4-speed Big Twins. Also fits all Paughco swingarm frames when using disc brakes. 15¾" center-to-center (OEM 45700-73)
- 153RC** Fits Paughco rubber mount frames and stock FXR applications (OEM 47820-81A)
- 153FLR** Fits Paughco '60s-style FL rubber mount frames

WIDE WISHBONE & STRAIGHT LEG RIGID FRAMES

TRIKE
KITS

SPRINGERS
& FORKS

HANDLEBARS
& RISERS

LIGHTING

FRAMES &
ACCESSORIES

WHEELS
& BRAKES

GAS & OIL
TANKS

SHEET
METAL

ENGINE &
ELECTRICAL

PRIMARY &
DRIVETRAIN

FOOT
CONTROLS

TRANSMISSION

EXHAUST

TOOLS &
GENERAL



131S5BW



S131S5BW

CALL FOR PRICES

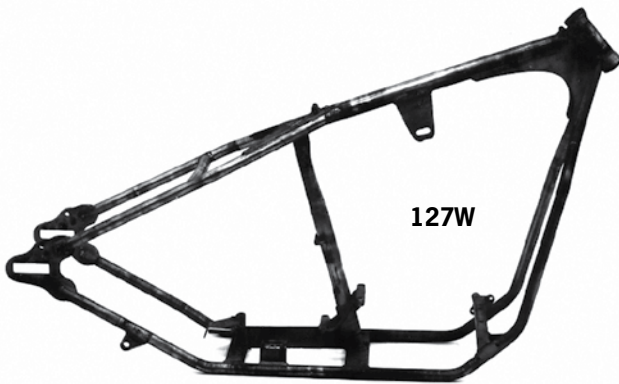

127W



S129W

WIDE RIGID WISHBONE FRAMES				WIDE RIGID STRAIGHT LEG FRAMES				OUT	UP	RAKE
OEM STYLE NECK		CHOPPER STYLE NECK		OEM STYLE NECK		CHOPPER STYLE NECK				
WITH FAT BOB MOUNTS	WITHOUT FAT BOB MOUNTS	WITH FAT BOB MOUNTS	WITHOUT FAT BOB MOUNTS	WITH FAT BOB MOUNTS	WITHOUT FAT BOB MOUNTS	WITH FAT BOB MOUNTS	WITHOUT FAT BOB MOUNTS			
4-SPEED TRANSMISSION										
S130W	S128W	130W	128W	S131W	S139W	131W	139W	0"	0"	30°
S129BW	S127BW	129BW	127BW	S132BW	S140BW	132BW	140BW	0"	2¼"	30°
S130AW	S128AW	130AW	128AW	S131AW	S139AW	131AW	139AW	0"	0"	35°
S129AW	S127AW	129AW	127AW	S132AW	S140AW	132AW	140AW	0"	2¼"	35°
S130BW	S128BW	130BW	128BW	S131BW	S139BW	131BW	139BW	0"	0"	40°
S129W	S127W	129W	127W	S132W	S140W	132W	140W	0"	2¼"	40°
SOFTAIL 5-SPEED TRANSMISSION										
S130S5W	S128S5W	130S5W	128S5W	S131S5W	S139S5W	131S5W	139S5W	0"	0"	30°
S129S5BW	S127S5BW	129S5BW	127S5BW	S132S5BW	S140S5BW	132S5BW	140S5BW	0"	2¼"	30°
S130S5AW	S128S5AW	130S5AW	128S5AW	S131S5AW	S139S5AW	131S5AW	139S5AW	0"	0"	35°
S129S5AW	S127S5AW	129S5AW	127S5AW	S132S5AW	S140S5AW	132S5AW	140S5AW	0"	2¼"	35°
S130S5BW	S128S5BW	130S5BW	128S5BW	S131S5BW	S139S5BW	131S5BW	139S5BW	0"	0"	40°
S129S5W	S127S5W	129S5W	127S5W	S132S5W	S140S5W	132S5W	140S5W	0"	2¼"	40°

TO ORDER THESE PARTS, CALL US AT 775-246-5738
OR TOLL FREE AT 800-423-2621



85

WISHBONE & STRAIGHT LEG RIGID FRAMES



WISHBONE AND STRAIGHT LEG RIGID FRAMES

The widest selection of 'standard' width rigid frames in the industry! They can be combined with a variety of drivetrains, including Shovelhead and Evolution engines, and most transmission and final drive combinations. Choose from Straight Leg or the timeless Wishbone frame styles with OEM or Chopper-style necks, with or without tank mounts for pre-1984 Fat Bob gas tanks or 1986-1999 'flatside' Softail gas tanks.

Refer To Instructions On Page 72 Before Ordering.

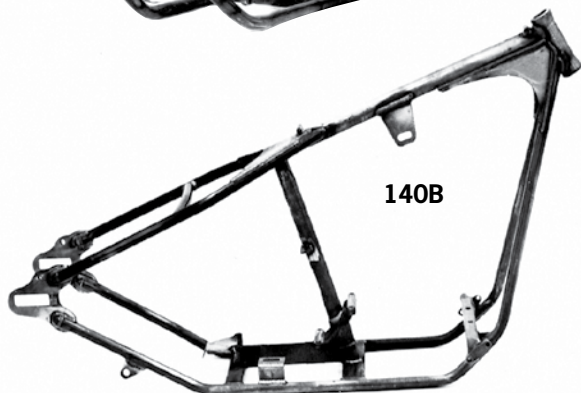
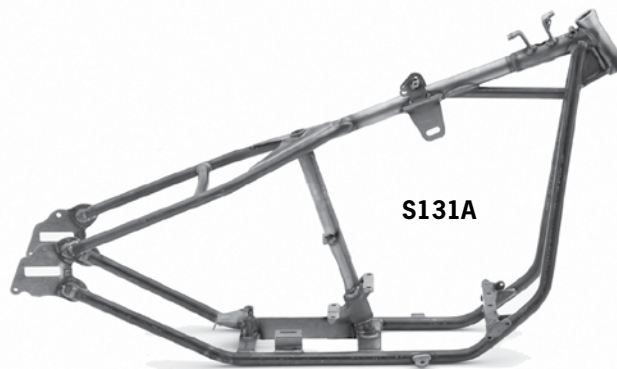
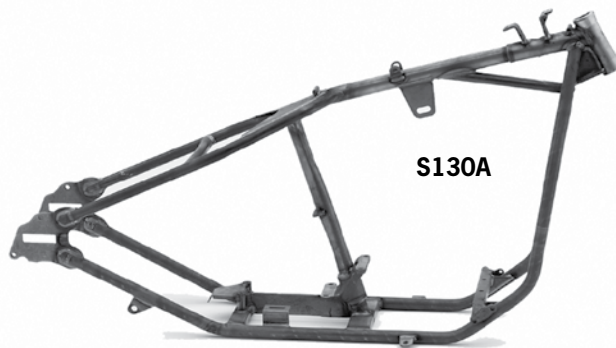
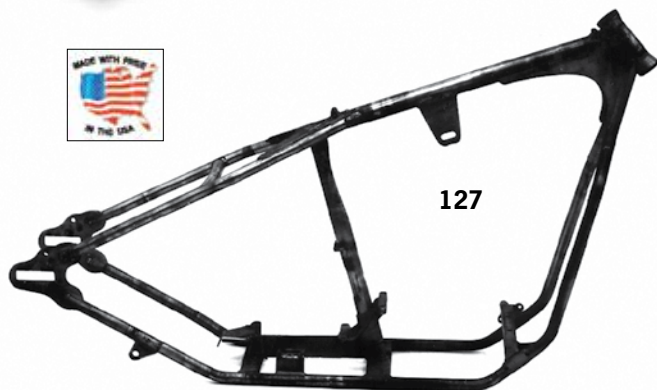

WISHBONE & STRAIGHT LEG RIGID FRAMES

TRIKE
KITS

SPRINGERS
& FORKS

HANDLEBARS
& RISERS

LIGHTING

FRAMES &
ACCESSORIES

WHEELS
& BRAKES

GAS & OIL
TANKS

SHEET
METAL

ENGINE &
ELECTRICAL

PRIMARY &
DRIVETRAIN

FOOT
CONTROLS

TRANSMISSION

EXHAUST

TOOLS &
GENERAL

TOOLS &
GENERAL

CALL FOR PRICES

SPECIAL NOTE:
FRAMES FOR 5-SPEED SOFTAIL TRANSMISSIONS INCLUDE
A PAUGHCO #218A TRANSMISSION MOUNTING PLATE.



RIGID STRAIGHT LEG FRAMES				RIGID WISHBONE FRAMES				OUT	UP	RAKE
OEM STYLE NECK		CHOPPER STYLE NECK		OEM STYLE NECK		CHOPPER STYLE NECK				
WITH FAT BOB MOUNTS	WITHOUT FAT BOB MOUNTS	WITH FAT BOB MOUNTS	WITHOUT FAT BOB MOUNTS	WITH FAT BOB MOUNTS	WITHOUT FAT BOB MOUNTS	WITH FAT BOB MOUNTS	WITHOUT FAT BOB MOUNTS			
4-SPEED TRANSMISSION WITH CHAIN FINAL DRIVE										
S131	S139	131	139	S130	S128	130	128	0"	0"	30°
S132B	S140B	132B	140B	S129B	S127B	129B	127B	0"	2¼"	30°
S131A	S139A	131A	139A	S130A	S128A	130A	128A	0"	0"	35°
S132A	S140A	132A	140A	S129A	S127A	129A	127A	0"	2¼"	35°
S131B	S139B	131B	139B	S130B	S128B	130B	128B	0"	0"	40°
S132	S140	132	140	S129	S127	129	127	0"	2¼"	40°
4-SPEED TRANSMISSION WITH BELT FINAL DRIVE										
S131RB	S139RB	131RB	139RB	S130RB	S128RB	130RB	128RB	0"	0"	30°
S132BRB	S140BRB	132BRB	140BRB	S129BRB	S127BRB	129BRB	127BRB	0"	2¼"	30°
S131ARB	S139ARB	131ARB	139ARB	S130ARB	S128ARB	130ARB	128ARB	0"	0"	35°
S132ARB	S140ARB	132ARB	140ARB	S129ARB	S127ARB	129ARB	127ARB	0"	2¼"	35°
S131BRB	S139BRB	131BRB	139BRB	S130BRB	S128BRB	130BRB	128BRB	0"	0"	40°
S132RB	S140RB	132RB	140RB	S129RB	S127RB	129RB	127RB	0"	2¼"	40°
FXR OR TOURING 5-SPEED TRANSMISSION WITH CHAIN FINAL DRIVE										
S131-5	S139-5	131-5	139-5	S130-5	S128-5	130-5	128-5	0"	0"	30°
S132-5B	S140-5B	132-5B	140-5B	S129-5B	S127-5B	129-5B	127-5B	0"	2¼"	30°
S131-5A	S139-5A	131-5A	139-5A	S130-5A	S128-5A	130-5A	128-5A	0"	0"	35°
S132-5A	S140-5A	132-5A	140-5A	S129-5A	S127-5A	129-5A	127-5A	0"	2¼"	35°
S131-5B	S139-5B	131-5B	139-5B	S130-5B	S128-5B	130-5B	128-5B	0"	0"	40°
S132-5	S140-5	132-5	140-5	S129-5	S127-5	129-5	127-5	0"	2¼"	40°
FXR OR TOURING 5-SPEED TRANSMISSION WITH BELT FINAL DRIVE										
S131-5RB	S139-5RB	131-5RB	139-5RB	S130-5RB	S128-5RB	130-5RB	128-5RB	0"	0"	30°
S132-5BRB	S140-5BRB	132-5BRB	140-5BRB	S129-5BRB	S127-5BRB	129-5BRB	127-5BRB	0"	2¼"	30°
S131-5ARB	S139-5ARB	131-5ARB	139-5ARB	S130-5ARB	S128-5ARB	130-5ARB	128-5ARB	0"	0"	35°
S132-5ARB	S140-5ARB	132-5ARB	140-5ARB	S129-5ARB	S127-5ARB	129-5ARB	127-5ARB	0"	2¼"	35°
S131-5BRB	S139-5BRB	131-5BRB	139-5BRB	S130-5BRB	S128-5BRB	130-5BRB	128-5BRB	0"	0"	40°
S132-5RB	S140-5RB	132-5RB	140-5RB	S129-5RB	S127-5RB	129-5RB	127-5RB	0"	2¼"	40°
SOFTAIL 5-SPEED TRANSMISSION WITH BELT FINAL DRIVE										
S131S5	S139S5	131S5	139S5	S130S5	S128S5	130S5	128S5	0"	0"	30°
S132S5B	S140S5B	132S5B	140S5B	S129S5B	S127S5B	129S5B	127S5B	0"	2¼"	30°
S131S5A	S139S5A	131S5A	139S5A	S130S5A	S128S5A	130S5A	128S5A	0"	0"	35°
S132S5A	S140S5A	132S5A	140S5A	S129S5A	S127S5A	129S5A	127S5A	0"	2¼"	35°
S131S5B	S139S5B	131S5B	139S5B	S130S5B	S128S5B	130S5B	128S5B	0"	0"	40°
S132S5	S140S5	132S5	140S5	S129S5	S127S5	129S5	127S5	0"	2¼"	40°

TO ORDER THESE PARTS, CALL US AT 775-246-5738
OR TOLL FREE AT 800-423-2621



'SWEDISH-STYLE' STRAIGHT LEG RIGID FRAMES



'SWEDISH-STYLE' STRAIGHT LEG RIGID FRAMES

These frames can be combined with a variety of drivetrains, including Shovelhead and Evolution engines with traditional 4-speed or 5-speed Softail transmissions. They feature a 'Chopper' style neck, and come in three different widths including our 'Extra-Wide' versions that will accept 240-series tires with a conventional 1½"-wide belt, or 250-series tires with a chain. The 'Standard' frames can accept a 130-series tire with a belt final drive, or a 150-series tire with a chain, and include a Paughco #218A Transmission Mounting Plate. And our 'Wide' frames can accept a 180-series tire with a belt or a 200-series tire with a chain.

Refer To Instructions On Page 72 Before Ordering.

SPECIAL NOTE:

STANDARD-WIDTH FRAMES FOR 5-SPEED SOFTAIL TRANSMISSIONS INCLUDE A PAUGHCO #218A TRANSMISSION MOUNTING PLATE.

'SWEDISH-STYLE' STRAIGHT LEG RIGID FRAMES

'STANDARD' FRAMES	'WIDE' FRAMES	'EXTRA-WIDE' FRAMES	OUT	UP	RAKE
-------------------	---------------	---------------------	-----	----	------

4-SPEED TRANSMISSION WITH CHAIN OR BELT DRIVE

140-24	140-24W	140-24X	2"	4"	30°
140-36	140-36W	140-36X	3"	6"	30°
140-48	140-48W	140-48X	4"	8"	30°
140-51	140-51W	140-51X	5"	10"	30°
140-24A	140-24AW	140-24AX	2"	4"	35°
140-36A	140-36AW	140-36AX	3"	6"	35°
140-48A	140-48AW	140-48AX	4"	8"	35°
140-51A	140-51AW	140-51AX	5"	10"	35°
140-24B	140-24BW	140-24BX	2"	4"	40°
140-36B	140-36BW	140-36BX	3"	6"	40°
140-48B	140-48BW	140-48BX	4"	8"	40°
140-51B	140-51BW	140-51BX	5"	10"	40°
140-24C	140-24CW	140-24CX	2"	4"	45°
140-36C	140-36CW	140-36CX	3"	6"	45°
140-48C	140-48CW	140-48CX	4"	8"	45°
140-51C	140-51CW	140-51CX	5"	10"	45°

5-SPEED TRANSMISSION WITH CHAIN OR BELT DRIVE

140S5-24	140S5-24W	140S5-24X	2"	4"	30°
140S5-36	140S5-36W	140S5-36X	3"	6"	30°
140S5-48	140S5-48W	140S5-48X	4"	8"	30°
140S5-51	140S5-51W	140S5-51X	5"	10"	30°
140S5-24A	140S5-24AW	140S5-24AX	2"	4"	35°
140S5-36A	140S5-36AW	140S5-36AX	3"	6"	35°
140S5-48A	140S5-48AW	140S5-48AX	4"	8"	35°
140S5-51A	140S5-51AW	140S5-51AX	5"	10"	35°
140S5-24B	140S5-24BW	140S5-24BX	2"	4"	40°
140S5-36B	140S5-36BW	140S5-36BX	3"	6"	40°
140S5-48B	140S5-48BW	140S5-48BX	4"	8"	40°
140S5-51B	140S5-51BW	140S5-51BX	5"	10"	40°
140S5-24C	140S5-24CW	140S5-24CX	2"	4"	45°
140S5-36C	140S5-36CW	140S5-36CX	3"	6"	45°
140S5-48C	140S5-48CW	140S5-48CX	4"	8"	45°
140S5-51C	140S5-51CW	140S5-51CX	5"	10"	45°

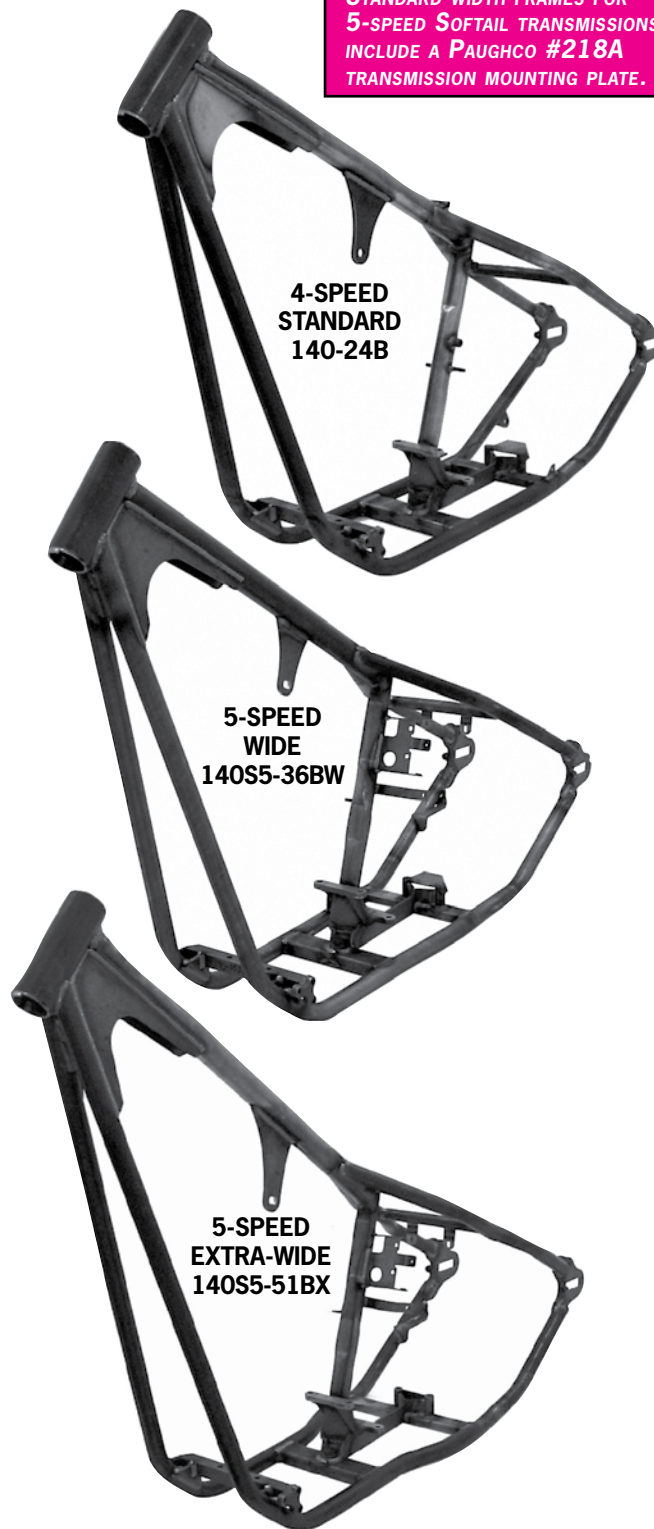

'SWEDISH-STYLE' STRAIGHT LEG 'EASYRIDE' FRAMES

'SWEDISH-STYLE' STRAIGHT LEG 'EASYRIDE' FRAMES

These frames can be combined with a variety of drivetrains, including Shovelhead and Evolution engines with traditional 4-speed or 5-speed Softail transmissions. They come in three different widths including our 'Extra-Wide' versions that will accept 240-series tires with a conventional 1½"-wide belt, or 250-series tires with a chain. The 'Standard' frames can accept a 130-series tire with a belt final drive, or a 150-series tire with a chain. And our 'Wide' frames can accept a 180-series tire with a belt or a 200-series tire with a chain.

Refer To Instructions On Page 72 Before Ordering.



SPECIAL NOTE:
EXTRA-WIDE FRAMES DO NOT HAVE INTEGRAL FRAME HORNS. BOLT-ON RAW STEEL STRUTS ARE AVAILABLE ON PAGE 98.

'SWEDISH-STYLE' STRAIGHT LEG 'EASYRIDE' FRAMES					
'STANDARD' FRAMES	'WIDE' FRAMES	'EXTRA-WIDE' FRAMES	OUT	UP	RAKE
4-SPEED TRANSMISSION WITH CHAIN OR BELT FINAL DRIVE					
E144-24	E144-24W	E144-24X	2"	4"	30°
E144-36	E144-36W	E144-36X	3"	6"	30°
E144-48	E144-48W	E144-48X	4"	8"	30°
E144-51	E144-51W	E144-51X	5"	10"	30°
E144-24A	E144-24AW	E144-24AX	2"	4"	35°
E144-36A	E144-36AW	E144-36AX	3"	6"	35°
E144-48A	E144-48AW	E144-48AX	4"	8"	35°
E144-51A	E144-51AW	E144-51AX	5"	10"	35°
E144-24B	E144-24BW	E144-24BX	2"	4"	40°
E144-36B	E144-36BW	E144-36BX	3"	6"	40°
E144-48B	E144-48BW	E144-48BX	4"	8"	40°
E144-51B	E144-51BW	E144-51BX	5"	10"	40°
E144-24C	E144-24CW	E144-24CX	2"	4"	45°
E144-36C	E144-36CW	E144-36CX	3"	6"	45°
E144-48C	E144-48CW	E144-48CX	4"	8"	45°
E144-51C	E144-51CW	E144-51CX	5"	10"	45°
5-SPEED TRANSMISSION WITH CHAIN OR BELT FINAL DRIVE					
E144S5-24	E144S5-24W	E144S5-24X	2"	4"	30°
E144S5-36	E144S5-36W	E144S5-36X	3"	6"	30°
E144S5-48	E144S5-48W	E144S5-48X	4"	8"	30°
E144S5-51	E144S5-51W	E144S5-51X	5"	10"	30°
E144S5-24A	E144S5-24AW	E144S5-24AX	2"	4"	35°
E144S5-36A	E144S5-36AW	E144S5-36AX	3"	6"	35°
E144S5-48A	E144S5-48AW	E144S5-48AX	4"	8"	35°
E144S5-51A	E144S5-51AW	E144S5-51AX	5"	10"	35°
E144S5-24B	E144S5-24BW	E144S5-24BX	2"	4"	40°
E144S5-36B	E144S5-36BW	E144S5-36BX	3"	6"	40°
E144S5-48B	E144S5-48BW	E144S5-48BX	4"	8"	40°
E144S5-51B	E144S5-51BW	E144S5-51BX	5"	10"	40°
E144S5-24C	E144S5-24CW	E144S5-24CX	2"	4"	45°
E144S5-36C	E144S5-36CW	E144S5-36CX	3"	6"	45°
E144S5-48C	E144S5-48CW	E144S5-48CX	4"	8"	45°
E144S5-51C	E144S5-51CW	E144S5-51CX	5"	10"	45°

TO ORDER THESE PARTS, CALL US AT 775-246-5738 OR TOLL FREE AT 800-423-2621



TRIKE KITS

SPRINGERS & FORKS

HANDLEBARS & RISERS

LIGHTING

FRAMES & ACCESSORIES

WHEELS & BRAKES

GAS & OIL TANKS

SHEET METAL

ENGINE & ELECTRICAL

PRIMARY & DRIVETRAIN

FOOT CONTROLS

TRANSMISSION

EXHAUST

TOOLS & GENERAL

STRAIGHT LEG 'EASYRIDE' SWINGARM FRAMES



1986-UP 'EASYRIDE' STRAIGHT LEG SWINGARM FRAMES

These frames can be combined with a variety of drivetrains, including Shovelhead and Evolution engines, with traditional 4-speed or 5-speed Softail transmissions. Choose from a 'Chopper' style or an OEM-style neck in standard and wide versions. Refer To Instructions On Page 72 Before Ordering.



E147S5



E147S5W FRAME WITH E153W SWINGARM (WHEEL, AXLE, PULLEY AND STRUTS NOT INCLUDED)



CUSTOM BIKE WITH E147S5B FRAME & E153 SWINGARM

CALL FOR PRICES

SPECIAL NOTES:
 1) STOCK HARLEY SHOCKS WILL NOT WORK WITH 4-SPEED TRANSMISSIONS. SMALLER-DIAMETER AFTERMARKET SHOCKS MUST BE USED.
 2) BOLT-ON STRUTS ARE AVAILABLE FOR FRAMES THAT DO NOT HAVE INTEGRAL FRAME HORNS FOR OEM-STYLE STRUTS (SEE PAGE 98).

STRAIGHT LEG 'EASYRIDE' FRAMES				WIDE STRAIGHT LEG 'EASYRIDE' FRAMES				OUT	UP	RAKE
OEM STYLE NECK		CHOPPER STYLE NECK		OEM STYLE NECK		CHOPPER STYLE NECK				
WITH FAT BOB MOUNTS	WITHOUT FAT BOB MOUNTS	WITH FAT BOB MOUNTS	WITHOUT FAT BOB MOUNTS	WITH FAT BOB MOUNTS	WITHOUT FAT BOB MOUNTS	WITH FAT BOB MOUNTS	WITHOUT FAT BOB MOUNTS			
4-SPEED TRANSMISSION WITH CHAIN OR BELT FINAL DRIVE										
E147	E145	EC147	EC145	E147W	E145W	EC147W	EC145W	0"	0"	30°
E146B	E144B	EC146B	EC144B	E146BW	E144BW	EC146BW	EC144BW	0"	2¼"	30°
E147A	E145A	EC147A	EC145A	E147AW	E145AW	EC147AW	EC145AW	0"	0"	35°
E146A	E144A	EC146A	EC144A	E146AW	E144AW	EC146AW	EC144AW	0"	2¼"	35°
E147B	E145B	EC147B	EC145B	E147BW	E145BW	EC147BW	EC145BW	0"	0"	40°
E146	E144	EC146	EC144	E146W	E144W	EC146W	EC144W	0"	2¼"	40°
SOFTAIL 5-SPEED TRANSMISSION WITH CHAIN OR BELT FINAL DRIVE										
E147S5	E145S5	EC147S5	EC145S5	E147S5W	E145S5W	EC147S5W	EC145S5W	0"	0"	30°
E146S5B	E144S5B	EC146S5B	EC144S5B	E146S5BW	E144S5BW	EC146S5BW	EC144S5BW	0"	2¼"	30°
E147S5A	E145S5A	EC147S5A	EC145S5A	E147S5AW	E145S5AW	EC147S5AW	EC145S5AW	0"	0"	35°
E146S5A	E144S5A	EC146S5A	EC144S5A	E146S5AW	E144S5AW	EC146S5AW	EC144S5AW	0"	2¼"	35°
E147S5B	E145S5B	EC147S5B	EC145S5B	E147S5BW	E145S5BW	EC147S5BW	EC145S5BW	0"	0"	40°
E146S5	E144S5	EC146S5	EC144S5	E146S5W	E144S5W	EC146S5W	EC144S5W	0"	2¼"	40°



'SWEDISH-STYLE' FRAMES FOR TWIN CAM ENGINES

'SWEDISH-STYLE' RIGID AND 'EASYRIDE' FRAMES FOR TWIN CAM 'B' ENGINES

Choose from our rigid or 'Easyride' swingarm frames designed specifically for use with counterbalanced Twin Cam 'B' engines and transmissions for Softails. The 'Standard' frames can accept a 130-series tire with a conventional 1½"-wide belt final drive, or a 150-series tire with a chain. The 'Wide' frames can accept a 180-series tire with a conventional rear belt drive, or a 200-series tire with a chain. These frames do not include mounts for any gas tanks, but may be special-ordered if desired.

Refer To Instructions On Page 72 Before Ordering.



B139S5-36BW

SPECIAL NOTES:

1) SWINGARMS FOR 'EASYRIDE' SOFTAIL FRAMES ARE SOLD SEPARATELY (SEE PAGE 94).

RIGID FRAMES FOR TWIN CAM 'B' SOFTAIL ENGINES				
STANDARD FRAMES	WIDE FRAMES	OUT	UP	RAKE
B139S5-24	B139S5-24W	2"	4"	30°
B139S5-36	B139S5-36W	3"	6"	30°
B139S5-48	B139S5-48W	4"	8"	30°
B139S5-51	B139S5-51W	5"	10"	30°
B139S5-24A	B139S5-24AW	2"	4"	35°
B139S5-36A	B139S5-36AW	3"	6"	35°
B139S5-48A	B139S5-48AW	4"	8"	35°
B139S5-51A	B139S5-51AW	5"	10"	35°
B139S5-24B	B139S5-24BW	2"	4"	40°
B139S5-36B	B139S5-36BW	3"	6"	40°
B139S5-48B	B139S5-48BW	4"	8"	40°
B139S5-51B	B139S5-51BW	5"	10"	40°
B139S5-24C	B139S5-24CW	2"	4"	45°
B139S5-36C	B139S5-36CW	3"	6"	45°
B139S5-48C	B139S5-48CW	4"	8"	45°
B139S5-51C	B139S5-51CW	5"	10"	45°

'EASYRIDE' FRAMES FOR TWIN CAM 'B' SOFTAIL ENGINES				
STANDARD FRAMES	WIDE FRAMES	OUT	UP	RAKE
B144S5-24	B144S5-24W	2"	4"	30°
B144S5-36	B144S5-36W	3"	6"	30°
B144S5-48	B144S5-48W	4"	8"	30°
B144S5-51	B144S5-51W	5"	10"	30°
B144S5-24A	B144S5-24AW	2"	4"	35°
B144S5-36A	B144S5-36AW	3"	6"	35°
B144S5-48A	B144S5-48AW	4"	8"	35°
B144S5-51A	B144S5-51AW	5"	10"	35°
B144S5-24B	B144S5-24BW	2"	4"	40°
B144S5-36B	B144S5-36BW	3"	6"	40°
B144S5-48B	B144S5-48BW	4"	8"	40°
B144S5-51B	B144S5-51BW	5"	10"	40°
B144S5-24C	B144S5-24CW	2"	4"	45°
B144S5-36C	B144S5-36CW	3"	6"	45°
B144S5-48C	B144S5-48CW	4"	8"	45°
B144S5-51C	B144S5-51CW	5"	10"	45°

TO ORDER THESE PARTS, CALL US AT 775-246-5738
OR TOLL FREE AT 800-423-2621



TRIKE
KITS

SPRINGERS
& FORKS

HANDLEBARS
& RISERS

LIGHTING

FRAMES &
ACCESSORIES

WHEELS
& BRAKES

GAS & OIL
TANKS

SHEET
METAL

ENGINE &
ELECTRICAL

PRIMARY &
DRIVETRAIN

FOOT
CONTROLS

TRANSMISSION

EXHAUST

TOOLS &
GENERAL

FRAMES FOR TWIN CAM ENGINES



OPTIONAL CENTER POST
AND COIL MOUNT BRACKET
767-88B

RIGID AND 'EASYRIDE' FRAMES FOR TWIN CAM 'B' ENGINES

Choose from Straight Leg or Wishbone rigid frames, or Straight Leg 'Easyride' swing-arm frames, designed specifically for use with counterbalanced Twin Cam 'B' engines and transmissions for Softails. They differ from the Paughco frames on the facing page by their lack of gas tank mounts, and their round-tube backbones instead of the boxed-style. The 'Standard' frames can accept a 130-series tire with a belt final drive, and a 150-series tire with a chain. The 'Wide' frames can accept a 180-series tire with a conventional 1½"-wide belt, or a 200-series tire with a chain. Don't forget to also order the optional center post and coil mounting bracket (sold separately).

767-88B Center post and coil mount bracket for 2000–2006 Softail models or Paughco Rigid and Easyride frames

Refer To Instructions On Page 72 Before Ordering.

SPECIAL NOTES:

1) SWINGARMS FOR 'EASYRIDE'
SOFTAIL FRAMES ARE SOLD
SEPARATELY (SEE PAGE 94).

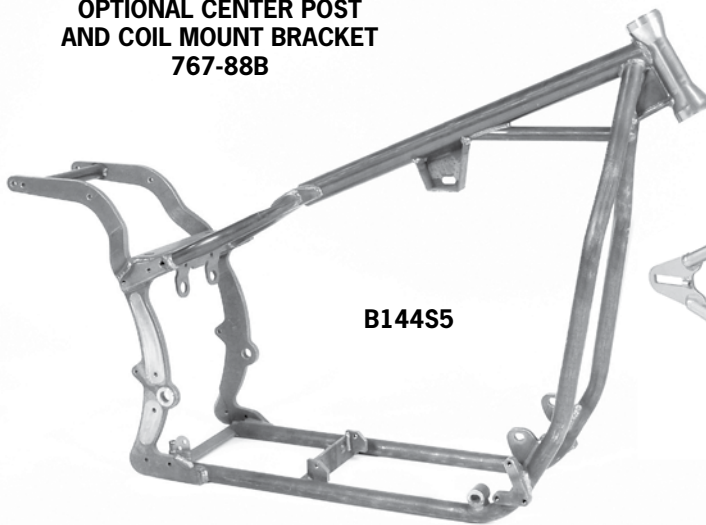

B144S5



B127S5B

STRAIGHT LEG 'EASYRIDE' AND RIGID FRAMES FOR TWIN CAM 'B' SOFTAIL ENGINES

'STANDARD' EASYRIDE	'WIDE' EASYRIDE	'STANDARD' RIGID	'WIDE' RIGID	OUT	UP	RAKE
B144S5	B144S5W	B140S5B	B140S5BW	0"	2¼"	30°
B144S5A	B144S5AW	B140S5A	B140S5AW	0"	2¼"	35°
B144S5B	B144S5BW	B140S5	B140S5W	0"	2¼"	40°

WISHBONE RIGID FRAMES FOR TWIN CAM 'B' SOFTAIL ENGINES

'STANDARD' RIGID	'WIDE' RIGID	OUT	UP	RAKE
B128S5	B128S5W	0"	0"	30°
B127S5B	B127S5BW	0"	2¼"	30°
B128S5A	B128S5AW	0"	0"	35°
B127S5A	B127S5AW	0"	2¼"	35°
B128S5B	B128S5BW	0"	0"	40°
B127S5	B127S5W	0"	2¼"	40°



FRAMES FOR TWIN CAM ENGINES

RIGID AND 'EASYRIDE' FRAMES FOR TWIN CAM 'B' ENGINES

Choose from our rigid or 'Easyride' swingarm frames designed specifically for use with counterbalanced Twin Cam 'B' engines and transmissions for Softails. The 'Standard' frames can accept a 130-series tire with a belt final drive, and a 150-series tire with a chain. The 'Wide' frames can accept a 180-series tire with a conventional 1½"-wide belt, or a 200-series tire with a chain. All frames include tank mounts for the stock-style one-piece Fat Bob gas tank. Don't forget to also order the optional center post and coil mounting bracket (sold separately).



767-88B Center post and coil mount bracket for 2000–2006 Softail models or Paughco Rigid and Easyride frames

Refer To Instructions On Page 72 Before Ordering.

SPECIAL NOTES:
1) SWINGARMS FOR 'EASYRIDE' SOFTAIL FRAMES ARE SOLD SEPARATELY (SEE PAGE 94).



B139S5



B145S5

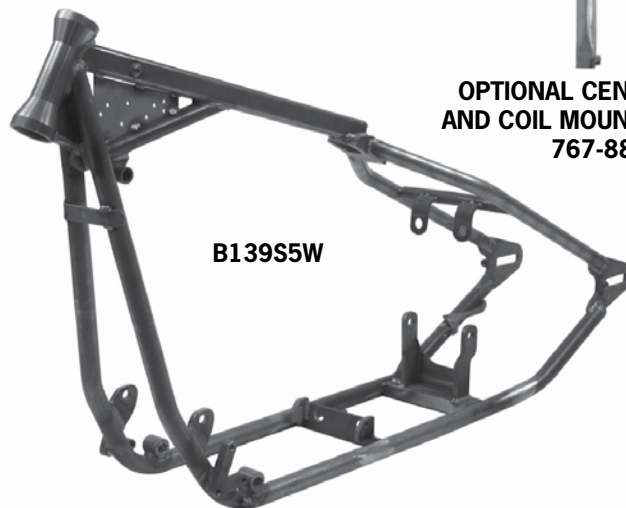

B139S5W

OPTIONAL CENTER POST AND COIL MOUNT BRACKET 767-88B



B145S5W

RIGID FRAMES FOR TWIN CAM 'B' SOFTAIL ENGINES				
'STANDARD' RIGID FRAMES	'WIDE' RIGID FRAMES	OUT	UP	RAKE
B139S5	B139S5W	0"	0"	30°
B139S5-2S	B139S5-2SW	2"	0"	30°
B139S5A	B139S5AW	0"	0"	35°
B139S5-2SA	B139S5-2SAW	2"	0"	35°
B139S5B	B139S5BW	0"	0"	40°
B139S5-2SB	B139S5-2SBW	2"	0"	40°

'EASYRIDE' FRAMES FOR TWIN CAM 'B' SOFTAIL ENGINES				
'STANDARD' EASYRIDE FRAMES	'WIDE' EASYRIDE FRAMES	OUT	UP	RAKE
B145S5	B145S5W	0"	0"	30°
B145S5-2S	B145S5-2SW	2"	0"	30°
B145S5A	B145S5AW	0"	0"	35°
B145S5-2SA	B145S5-2SAW	2"	0"	35°
B145S5B	B145S5BW	0"	0"	40°
B145S5-2SB	B145S5-2SBW	2"	0"	40°

TO ORDER THESE PARTS, CALL US AT 775-246-5738
OR TOLL FREE AT 800-423-2621



SWINGARMS & PARTS



FOR PAUGHCO TWIN CAM AND STANDARD 'EASYRIDE' SWINGARM FRAMES

Choose from two different swingarm styles, and then mount it with the available hardware. Most of the mounting kits and hardware will also fit stock HD swingarms.

SWINGARMS ONLY FOR 3/4" AXLES

- E153** Easyride swingarm (OEM 47573-89)
- E153-1** Easyride tube-style swingarm
- B153** Same as Paughco #E153, but only for Twin Cam Easyride frames (not shown)
- B153-1** Same as Paughco #E153-1, but only for Twin Cam Easyride frames (not shown)

MOUNTING KITS AND REPLACEMENT PARTS

- E154** Swingarm pivot tube (OEM 48031-89A)
- E154D** Pivot bearings and snap rings for 1986-1999 (sold in pairs) OEM 11158 and 9076
- E154D-1** Pivot bearings and snap rings for 2000-2007 (sold in pairs) OEM 11282 and 9270
- E154C** Swingarm pivot tube bolts and star washers (sold in pairs) OEM 4961 and 7142
- E154E** Shock bolts and washers for 1984-1999 style shocks (set of 4) OEM 4074 and 6724
- BE154E-2** Shock bolts and washers for 2000-up shocks (set of 2) OEM 4074 and 6724 (not shown)
- E154F** Spacers for swingarm pivot bolts (sold in pairs) OEM 43283-86
- E154K** Mounting kit for Paughco #'s E153 and E153-1 swingarms (includes #'s E154, E154C, E154D, E154E and E154F)
- B154K** Mounting kit for Paughco #'s B153 and B153-1 swingarms (includes all hardware)
- B154E** Pivot shaft ONLY for #'s B153 and B153-1
- 24K** Axle kit for Paughco #'s E153 and E153-1 swingarms (includes #'s 24, 33D8, 33D4, 39, 40 and 32) see page 121
- B24K** Axle kit for Paughco #'s B153 and B153-1 swingarms (includes hardware) see page 121
- E157** Aluminum rock guard

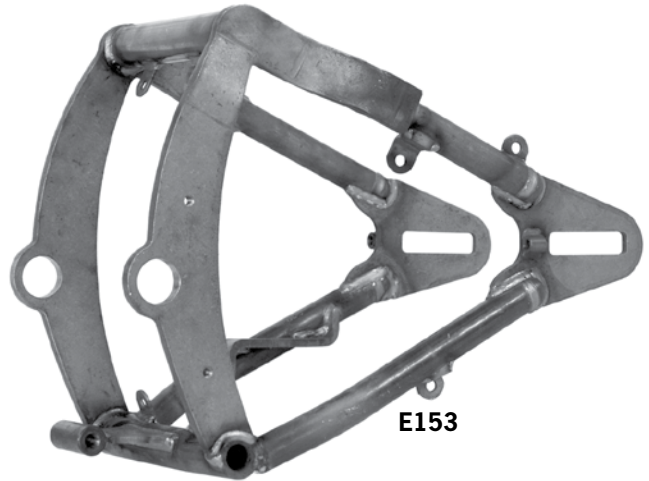

E153

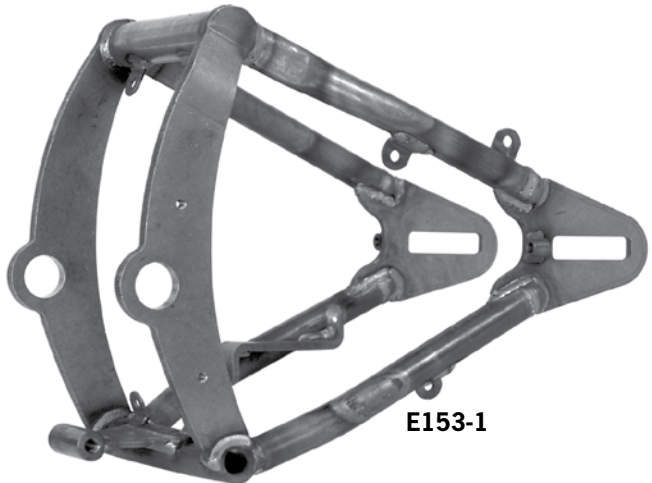

E153-1

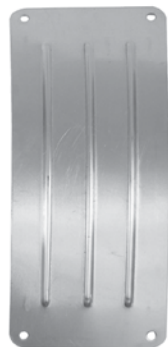

E157



24K AXLE KIT



B24K AXLE KIT



E154



E154E



E154C

E154F

E154D

E154D

E154F

E154C



**B154K
PIVOT KIT**

B154E SHAFT



WIDE SWINGARMS & PARTS

FOR PAUGHCO WIDE TWIN CAM AND WIDE 'EASYRIDE' SWINGARM FRAMES

Choose from two different swingarm styles, and then mount it with the available hardware. Some of the hardware will also fit stock HD swingarms.



TRIKE KITS

SPRINGERS & FORKS

HANDLEBARS & RISERS

LIGHTING

FRAMES & ACCESSORIES

WHEELS & BRAKES

GAS & OIL TANKS

SHEET METAL

ENGINE & ELECTRICAL

PRIMARY & DRIVETRAIN

FOOT CONTROLS

TRANSMISSION

EXHAUST

TOOLS & GENERAL

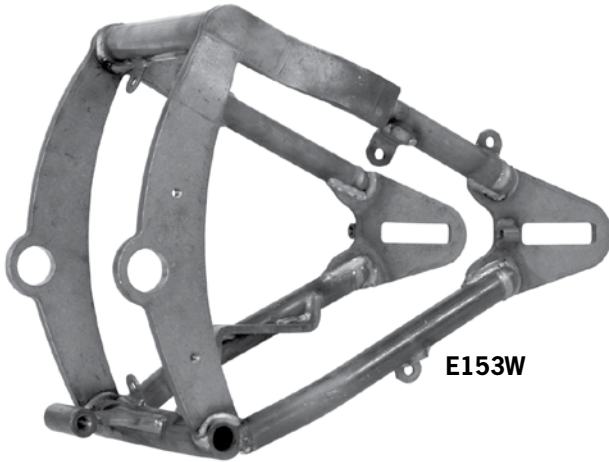

E153W



E153-1W

SWINGARMS ONLY FOR 3/4" AXLES

- E153W** Wide Easyride swingarm
- E153-1W** Wide Easyride tube-style swingarm
- B153W** Same as Paughco #E153W, but only for Twin Cam Wide Easyride frames (not shown)
- B153-1W** Same as Paughco #E153-1W, but only for Twin Cam Wide Easyride frames (not shown)

MOUNTING KITS AND REPLACEMENT PARTS

- E154W** Wide swingarm pivot tube
- E154D** Pivot bearings and snap rings for 1986-1999 (sold in pairs) OEM 11158 and 9076
- E154D-1** Pivot bearings and snap rings for 2000-2007 (sold in pairs) OEM 11282 and 9270
- E154C** Swingarm pivot tube bolts and star washers (sold in pairs) OEM 4961 and 7142
- E154E** Shock bolts and washers for 1984-1999 style shocks (set of 4) OEM 4074 and 6724
- BE154E-2** Shock bolts and washers for 2000-up shocks (set of 2) OEM 4074 and 6724 (not shown)
- E154F** Spacers for swingarm pivot bolts (sold in pairs) OEM 43283-86
- E154WK** Mounting kit for Paughco #'s E153W and E153-1W swingarms (includes #'s E154W, E154C, E154D, E154E and E154F)
- B154WK** Mounting kit for Paughco #'s B153W and B153-1W swingarms (includes all hardware)
- B154WE 24WK** Wide pivot shaft ONLY
- B24WK** Axle kit for Paughco #'s E153W and E153-1W swingarms (includes #'s 24W, 33D8, 33D5, 39, 40 and 32) see page 121
- B24WK** Axle kit for Paughco #'s B153W and B153-1W swingarms (includes all hardware) see page 121
- E157W** Wide aluminum rock guard



E154W



E154E



B24WK AXLE KIT

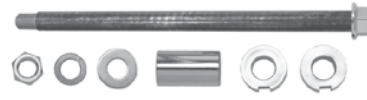

24WK AXLE KIT



B154WK PIVOT KIT

B154WE



E154D

E154F

E154C



E157W

TO ORDER THESE PARTS, CALL US AT 775-246-5738
OR TOLL FREE AT 800-423-2621



EXTRA-WIDE SWINGARMS & PARTS



FOR PAUGHCO EXTRA-WIDE 'EASYSIDE' SWINGARM FRAMES

Choose from two different swingarm styles, and then mount it with the available hardware. Some of the hardware will also fit stock HD swingarms.

SWINGARMS ONLY FOR 3/4" AXLES

- E153X** Extra-wide Easyride swingarm
- E153-1X** Extra-wide tube-style Easyride swingarm

MOUNTING KITS AND REPLACEMENT PARTS

- E154X** Extra-wide swingarm pivot tube
- E154D** Pivot bearings and snap rings for 1986-1999 (sold in pairs) OEM 11158 and 9076
- E154C** Swingarm pivot tube bolts and star washers (sold in pairs) OEM 4961 and 7142
- E154E** Shock bolts and washers for 1984-1999 style shocks (set of 4) OEM 4074 and 6724
- E154F** Spacers for swingarm pivot bolts (sold in pairs) OEM 43283-86
- E154XK** Mounting kit for Paughco #'s E153X and E153-1X swingarms (includes #'s E154X, E154C, E154D, E154E and E154F)
- 24XK** Axle kit for Paughco #'s E153X and E153-1X swingarms (includes #'s 24X, 33D8, 39, 40 and 32) see page 121

Note: Left-side axle spacer length will need to be determined with Paughco Kit #24XK to properly space the hub on custom wheels.

- E157X** Extra-wide aluminum rock guard

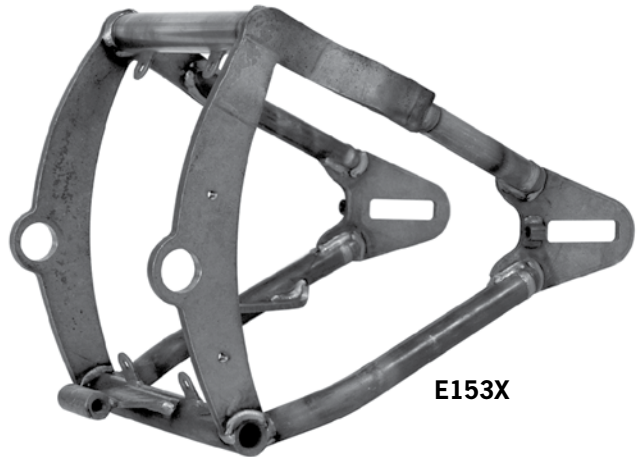

E153X

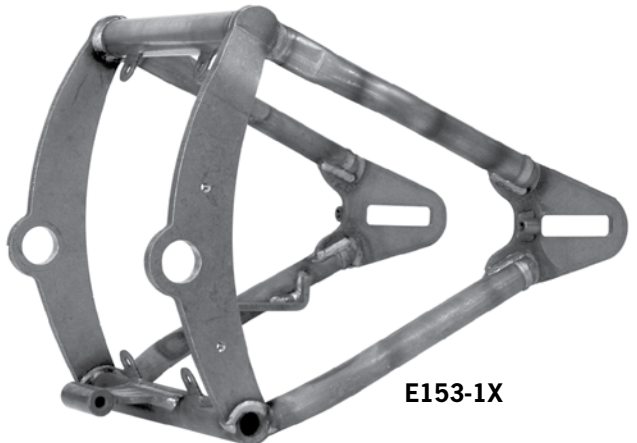

E153-1X

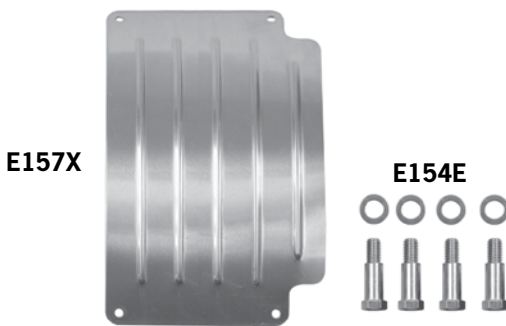

E157X

E154E



E154X



24XK AXLE KIT



E154C

E154F

E154D



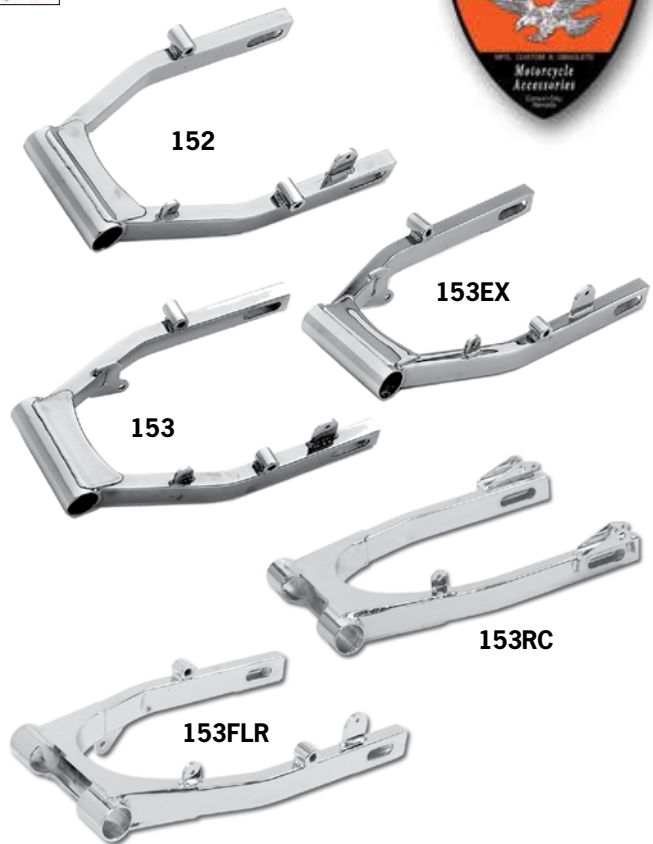
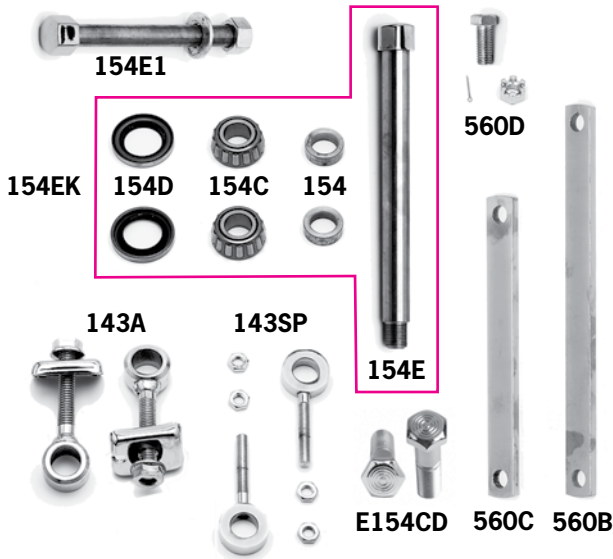

REPLACEMENT SWINGARM PARTS FOR HD AND PAUGHCO FRAMES

A nice selection of swingarm accessories and replacement parts for late 4-speed and 5-speed Big Twin models and early Sportsters can be found here.

- E154CD** Decorative chrome swingarm pivot tube bolts (sold in pairs)
- 560B** Chrome anchor arm (mounting holes are 11" center-to-center)
- 560C** Chrome anchor arm (mounting holes are 8" center-to-center)
- 560D** Anchor arm mounting kit (includes 1/2" bolt, castle nut and cotter pin) OEM 41734-73 (sold in pairs)
- 154EK** Swingarm pivot bolt kit for 4-speed Big Twins from 1958-1984 (includes items in red box)
- 154E** Chrome swingarm pivot bolt ONLY for 4-speed Big Twins from 1958-1984
- 154D** Swingarm bearing seals (sold in pairs) OEM 47519-58
- 154C** Replacement bearings for 4-speed Big Twin swingarms from 1958-1984 (sold in pairs)
- 154** Swingarm bearing spacers (sold in pairs)
- 154E1** Rear bolt for FXR and Touring model transmissions installed in Paughco 5-speed frames
- 741FXRBR** Isolator mount for 1980-up Touring and FXR models (2 required) not shown
- R154S** Pivot shaft for 1980-2001 Touring and FXR models (OEM 47492-89A) not shown
- 143A** Stock replacement wheel adjusters for 1973 thru 2001 Big Twins (except Dyna Glides and 1987-up Softails) and 1979-2003 Sportsters (sold in pairs) OEM 41570-77
- 143SP** Stock replacement wheel adjusters for 1954-1978 Sportster and K-model rigid and swingarm frames (OEM 39985-52)

CUSTOM AND STOCK REPLACEMENT CHROME SWINGARMS FOR HD AND PAUGHCO FRAMES

- 152** Replacement swingarm for 1972-1983 chain drive 4-speed Big Twins. Also fits all Paughco swingarm frames when using disc brakes. 15³/₄" center-to-center (OEM 45700-73)
- 153EX** 2" extended swingarm for all 4-speed belt drive frames, and Paughco swingarm frames with Softail 5-speed transmissions. Permits smaller rear wheel pulley to be run with stock belt to increase final drive ratio. 17³/₄" center-to-center
- 153** Fits all 4-speed belt drive frames. Also fits Paughco swingarm frames with Softail 5-speed transmissions. 15³/₄" center-to-center (OEM 47446-79). Use Paughco #25AK axle with this swingarm
- 153RC** Fits Paughco rubber mount frames and stock FXR applications (OEM 47820-81A). Use Paughco #25AK axle with this swingarm
- 153FLR** Fits Paughco '60s-style FL rubber mount frames

SPECIAL NOTES:

- 1) ALL SWINGARMS ON THIS PAGE COME CHROMED, BUT MAY BE ORDERED WITH A RAW STEEL FINISH.
- 2) SWINGARMS HAVE THEIR BEARING RACES ALREADY INSTALLED.

TO ORDER THESE PARTS, CALL US AT 775-246-5738
OR TOLL FREE AT 800-423-2621



TRIKE
KITS

SPRINGS
& FORKS

HANDLEBARS
& RISERS

LIGHTING

FRAMES &
ACCESSORIES

WHEELS
& BRAKES

GAS & OIL
TANKS

SHEET
METAL

ENGINE &
ELECTRICAL

PRIMARY &
DRIVETRAIN

FOOT
CONTROLS

TRANSMISSION

EXHAUST

TOOLS &
GENERAL

BELT GUARDS & 'EASYRIDE' FRAME ACCESSORIES



BELT GUARDS AND 'EASYRIDE' FRAME ACCESSORIES

Choose from a wide selection of belt and rock guards, fender struts, inner primary adapters, and a host of other engine components.

- E514T** Custom top belt guard for 65-tooth pulley
- E514B** Custom bottom belt guard for 65-tooth pulley
- E514-1T** Custom top belt guard for 70-tooth pulley
- E514-1B** Custom bottom belt guard for 70-tooth pulley
- E157** Aluminum swingarm rock guard
- E157W** Wide aluminum swingarm rock guard
- E157X** Extra-wide aluminum swingarm rock guard
- E155** 1/2"-thick inner primary spacer for Paughco wide frames
- E155W** 1"-thick inner primary spacer for Paughco wide frames (not shown)
- E155X** 1 1/2"-thick inner primary spacer for Paughco extra-wide frames
- 741TC** Adapter plate for Twin Cam engines (does not work with counterbalanced Twin Cam 'B' Softtail engines)



BOLT-ON RAW STEEL FENDER STRUTS FOR STANDARD 'EASYRIDE' FRAMES WITHOUT WELD-ON STRUTS

E159 For 6"-wide fenders

BOLT-ON RAW STEEL FENDER STRUTS FOR PAUGHCO WIDE FRAMES

- E159W** For 7 1/2"-wide fenders
- E160W** For 8 1/2"-wide fenders
- E161W** For 9"-wide fenders



'SWEDISH-STYLE' SPORTSTER RIGID FRAMES



120EB36



120EB24



'SWEDISH-STYLE' RIGID FRAMES FOR SPORTSTER ENGINES

Available to fit engines from 1957 thru 2003, these frames come in your choice of a standard width rear section, or a wide one for oversized tires. The standard frames can accept a 130-series tire with a conventional 1 1/8" wide rear belt drive assembly or a chain, and the wide frames can be fitted with a 180-series tire when using a stock belt, or a 200-series tire when using a chain. All of these frames have Chopper-style necks, but they do not include gas tank mounts.

Refer To Instructions On Page 72 Before Ordering.

'SWEDISH-STYLE' SPORTSTER RIGID FRAMES

STANDARD FRAME	WIDE FRAME	OUT	UP	RAKE
FOR 1986-2003 ENGINES				
120E24	120E24W	2"	4"	30°
120E36	120E36W	3"	6"	30°
120EA24	120EA24W	2"	4"	35°
120EA36	120EA36W	3"	6"	35°
120EB24	120EB24W	2"	4"	40°
120EB36	120EB36W	3"	6"	40°
FOR 1977-1985 ENGINES				
120X24	120X24W	2"	4"	30°
120X36	120X36W	3"	6"	30°
120XA24	120XA24W	2"	4"	35°
120XA36	120XA36W	3"	6"	35°
120XB24	120XB24W	2"	4"	40°
120XB36	120XB36W	3"	6"	40°
FOR 1957-1976 ENGINES				
120-24		2"	4"	30°
120-36		3"	6"	30°
120-24A		2"	4"	35°
120-36A		3"	6"	35°
120-24B		2"	4"	40°
120-36B		3"	6"	40°

**TO ORDER THESE PARTS, CALL US AT 775-246-5738
OR TOLL FREE AT 800-423-2621**



SPORTSTER SWINGARM & WIDE TIRE RIGID FRAMES



WIDE TIRE RIGID FRAMES FOR 1977 THRU 2003 SPORTSTER ENGINES

1986-2003 ENGINES		1977-1985 ENGINES	OUT	UP	RAKE
WITHOUT TANK MOUNTS	WITH FAT BOB TANK MOUNTS	WITHOUT TANK MOUNTS			
120EW	120EFW	120XW	0"	0"	30°
120ECW	120EFCW	120XCW	0"	2¼"	30°
120EAW	120EFAW	120XAW	0"	0"	35°
120ECAW	120EFCAW	120XCAW	0"	2¼"	35°
120EBW	120EFBW	120XBW	0"	0"	40°
120ECBW	120EFCBW	120XCBW	0"	2¼"	40°



WIDE TIRE RIGID FRAMES FOR 1977 THRU 2003 SPORTSTER ENGINES

All frames have the Chopper neck, and use 1" neck bearings. They're available with or without pre-1985 Fat Bob tank mounts to fit engines from 1977 thru 2003. They will accept up to a 180-series tire with a belt, and up to a 200-series tire with a chain.

Refer To Instructions On Page 72 Before Ordering.



1986-1990
SA120E-24A



1991-2003
SAL120E

SWINGARM FRAMES FOR 1986 THRU 2003 EVOLUTION SPORTSTERS

These frames are a practical solution for adding a classic 'Chopper' look by taking your stock XL and adding more stretch and neck rake. All stock component parts bolt right back onto the frame. Simply choose a new tank and a longer Paughco Springer front end, or extend your stock forks if desired. Create your own unique bike to your own personal taste, quickly and easily. All mounting tabs are included (except for the tank mounts on frames that have any stretch in the backbone). The stock swingarm, fenders, struts, oil tank and controls bolt right back in their original positions.

SWINGARM FRAMES FOR 1986 THRU 2003 EVOLUTION SPORTSTER ENGINES

1991-2003 ENGINES	1986-1990 ENGINES	OUT	UP	RAKE
SAL120E	SA120E	0"	0"	30°
SAL120E-24	SA120E-24	2"	4"	30°
SAL120E-36	SA120E-36	3"	6"	30°
SAL120EA	SA120EA	0"	0"	35°
SAL120E-24A	SA120E-24A	2"	4"	35°
SAL120E-36A	SA120E-36A	3"	6"	35°
SAL120EB	SA120EB	0"	0"	40°
SAL120E-24B	SA120E-24B	2"	4"	40°
SAL120E-36B	SA120E-36B	3"	6"	40°



SPORTSTER RIGID FRAMES

TRIKE
KITS

SPRINGERS
& FORKS

HANDLEBARS
& RISERS

LIGHTING

FRAMES &
ACCESSORIES

WHEELS
& BRAKES

GAS & OIL
TANKS

SHEET
METAL

ENGINE &
ELECTRICAL

PRIMARY &
DRIVETRAIN

FOOT
CONTROLS

TRANSMISSION

EXHAUST

TOOLS &
GENERAL



1957-1976
120A



1957-1976
S120A

RIGID FRAMES FOR 1957 THRU 2003 SPORTSTERS

For engines from 1957 thru 2003, these frames have standard width rear sections that accept a 130-series tire with a conventional 1 1/8" wide rear belt drive or a chain. Choose from OEM or Chopper-style necks, with or without tank mounts for pre-1985 Fat Bob gas tanks or 1984-1999 'flatside' Softail gas tanks.

Refer To Instructions On
Page 72 Before Ordering.

CALL FOR PRICES

RIGID FRAMES FOR 1957-2003 SPORTSTER ENGINES				OUT	UP	RAKE
OEM STYLE NECK		CHOPPER STYLE NECK				
WITH FAT BOB MOUNTS	WITHOUT FAT BOB MOUNTS	WITH FAT BOB MOUNTS	WITHOUT FAT BOB MOUNTS			
FOR 1986-2003 ENGINES						
S120EF	S120E	120EF	120E	0"	0"	30°
S120EFC	S120EC	120EFC	120EC	0"	2 1/4"	30°
S120EFA	S120EA	120EFA	120EA	0"	0"	35°
S120EFCA	S120ECA	120EFCA	120ECA	0"	2 1/4"	35°
S120EFB	S120EB	120EFB	120EB	0"	0"	40°
S120EFCB	S120ECB	120EFCB	120ECB	0"	2 1/4"	40°
FOR 1977-1985 ENGINES						
S120XF	S120X	120XF	120X	0"	0"	30°
S120XFC	S120XC	120XFC	120XC	0"	2 1/4"	30°
S120XFA	S120XA	120XFA	120XA	0"	0"	35°
S120XFCA	S120XCA	120XFCA	120XCA	0"	2 1/4"	35°
S120XFB	S120XB	120XFB	120XB	0"	0"	40°
S120XFCB	S120XCB	120XFCB	120XCB	0"	2 1/4"	40°
FOR 1957-1976 ENGINES						
S120F	S120	120F	120	0"	0"	30°
S120FA	S120A	120FA	120A	0"	0"	35°
S120FB	S120B	120FB	120B	0"	1 1/2"	40°



1977-1985
S120XC



1986-2003
S120E

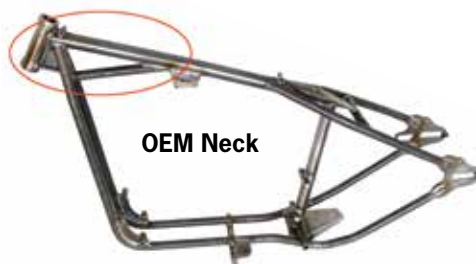

OEM Neck



Chopper Neck

TO ORDER THESE PARTS, CALL US AT 775-246-5738
OR TOLL FREE AT 800-423-2621



SPORTSTER RIGID FRAMES



SINGLE LOOP RIGID BOBBER FRAMES FOR 1986-2003 EVOLUTION SPORTSTER ENGINES

These all-new frames feature a distinctive 1½"-diameter single loop front downtube and 1⅛"-diameter lower frame rails. These frames build great looking small, low and cool-styled "Bobbers" as well as long, lean "Choppers." You pick the size and style and Paughco will custom build it to suit your tastes. Add a Paughco Springer and you can have a very special one-of-a-kind ride! See chart below for part numbers.

SINGLE LOOP BOBBER FRAMES FOR 1986-2003 SPORTSTER ENGINES	OUT	UP	RAKE
SLP120	0"	0"	30°
SLP120-24	2"	4"	30°
SLP120-36	3"	6"	30°
SLP120A	0"	0"	35°
SLP120-24A	2"	4"	35°
SLP120-36A	3"	6"	35°
SLP120B	0"	0"	40°
SLP120-24B	2"	4"	40°
SLP120-36B	3"	6"	40°

RIGID FRAMES FOR 2004-UP SPORTSTER RUBBER-MOUNTED ENGINES

All-new "rubber mount" rigid frames for 2004 and later Sportster model drivelines. All of the OEM engine mounts simply transfer over to the frame, permitting a quick and easy build of a great-looking custom. Available in all the popular stretches and rakes. Frames feature a 1½"-diameter backbone with 1¼"-diameter downtubes, and require a special round oil tank and rear axle kit that are sold separately. See chart below for part numbers.

- 746RDXML** Round oil tank for 2004-up frames
- 26RK** Chrome axle kit for 2004-up frames

RIGID FRAMES FOR 2004-UP RUBBER-MOUNTED SPORTSTER ENGINES	OUT	UP	RAKE
RS120E	0"	0"	30°
RS120E-24	2"	4"	30°
RS120E-36	3"	6"	30°
RS120EA	0"	0"	35°
RS120E-24A	2"	4"	35°
RS120E-36A	3"	6"	35°
RS120EB	0"	0"	40°
RS120E-24B	2"	4"	40°
RS120E-36B	3"	6"	40°

RUBBER MOTOR MOUNT BUSHINGS FOR 2004-UP SPORTSTERS

Perfect reproductions of the factory rubber mounts. Sold each.

741XLBF Front mount (OEM 48463-04)

741XLBR Rear mount (OEM 48492-04)

741XLBF



741XLBR

ROLLING CHASSIS KITS



THE LTC CHOPPER (LONG TIME COMING!!)

This Sportster kit was specially-constructed from all of our best selling parts to create this jaw dropping custom Chopper. An industry first, this rolling chassis kit features a wide tire frame with 3" out and 6" up, and a 40° neck rake. A beautiful 18" over tapered leg Springer with shock and brake mounts is included, as well as the wheels, tires, front brake and rotor, headlight, handlebars, risers, oil tank, rear fender, seat and sissy bar.

LTC-KIT LTC Chopper roller

THE LB BOBBER ('LOW BUDGE')

This rolling chassis kit can be powered with a 1986 thru 2003 Evolution Sportster engine. It was designed to provide the builder a platform to assemble a bike without breaking the bank. This kit includes one of Paughco's Sportster frames, a flawlessly chromed, stock length Springer. Additionally, you get the front fender kit, rotor, front and rear axle kits, wheels, tires, headlight, handlebars, risers, oil tank and battery box, gas tank, rear fender, seat and sissy bar.

LB-KIT LB Bobber rolling chassis kit

45" FLATHEAD ROLLING CHASSIS KIT SHOWN WITH ADDITIONAL COMPONENTS FOR ILLUSTRATION PURPOSES ONLY



THE 45" FLATHEAD BOBBER

This rolling chassis kit is meant to be powered by a 45" Flathead engine mated to an early 4-speed Big Twin transmission. It will provide the builder a platform to assemble a bike that separates himself from the crowd, without breaking the bank. The kit includes one of Paughco's 45" frames and a flawlessly chromed, 2" under stock length Wide Springer. Additionally, you get a 3-quart barrel-style oil tank, front and rear axle kits, 16" rear and 21" front wheels, headlight with mount, Mini-Z handlebars, 3"-tall dogbone risers, gas tank, flat rear fender, seat and sissy bar.

FH-KIT 45" Bobber rolling chassis kit

TO ORDER THESE PARTS, CALL US AT 775-246-5738 OR TOLL FREE AT 800-423-2621



TRIKE KITS

SPRINGERS & FORKS

HANDLEBARS & RISERS

LIGHTING

FRAMES & ACCESSORIES

WHEELS & BRAKES

GAS & OIL TANKS

SHEET METAL

ENGINE & ELECTRICAL

PRIMARY & DRIVETRAIN

FOOT CONTROLS

TRANSMISSION

EXHAUST

TOOLS & GENERAL

'CAPTAIN AMERICA' PARTS BY PAUGHCO



'CAPTAIN AMERICA' REPRODUCTION PARTS

Paughco has been making many of the parts found on the famous 'Captain America' bike seen in the 'Easy Rider' movie for years. Now we've put them all together in one location for you to pick and choose the ones you want to build your own version of the famous bike. From the impossible to build chrome wishbone frame to the iconic U.S. flag gas tank and unique King/Queen seat, Paughco has all the parts you need to build your own Captain. We have an original 4-speed frame for a perfect copy or even a 5-speed frame for updating to a Softtail driveline with an electric start.

ORIGINAL BIKE 4-SPEED PARTS

S127CC Chrome 4-speed Wishbone frame (3" front downtube stretch, 0" backbone stretch, 37° rake)

S127C Raw 4-speed Wishbone frame (3" front downtube stretch, 0" backbone stretch, 37° rake)

26BK Rear axle kit

218 4-speed transmission mounting plate

119CA Captain America sissy bar (chain drive)

748 Chrome oil tank

526D Chrome side-mount headlight bracket

539CA Chrome taillight mounting brackets (pair)

357 5"-tall Dog Bone risers

CTCA Chrome cross tube for risers

H31CA Special Captain America handlebars

715B Chrome upsweep headpipe set (Panheads)

606 Chrome Fishtail mufflers (sold each)

725C Exhaust clamp with tail (sold each)

753E Chrome tin inner primary

751 Chrome tin outer primary

757A Chrome derby cover with bird

758 Chrome tin inspection cover

515 Chrome chain guard



'CAPTAIN AMERICA' PARTS BY PAUGHCO

TRIKE
KITS

SPRINGERS
& FORKS

HANDLEBARS
& RISERS

LIGHTING

FRAMES &
ACCESSORIES

WHEELS
& BRAKES

GAS & OIL
TANKS

SHEET
METAL

ENGINE &
ELECTRICAL

PRIMARY &
DRIVETRAIN

FOOT
CONTROLS

TRANSMISSION

EXHAUST

TOOLS &
GENERAL



SPECIAL NOTE:

1) THE PARTS LISTED ON PAGES 104 & 105 ARE THE ONLY PARTS AVAILABLE FROM PAUGHCO TO BUILD A REPLICA OF THE CAPTAIN AMERICA MOTORCYCLE.

'MODERN UPDATED 5-SPEED' PARTS

S127S5CC Chrome 5-speed Wishbone frame (3" front downtube stretch, 0" backbone stretch, 37° rake)

S127S5C Raw 5-speed Wishbone frame (3" front downtube stretch, 0" backbone stretch, 37° rake)

26AK Rear axle kit

119TCA Captain America sissy bar (belt drive)

746ST-SPEC Chrome oil tank

218A 5-speed transmission plate

02-322 Triple clamps with 6° rake (1" stem)

142-1FS Internal fork stop kit

1310 Chrome 5¾" headlight

I31 13"-tall Apehanger handlebars

716BCA Chr. upsweep headpipe set (Shovelheads)

715BSTDCA Chrome upsweep headpipe set (STD heads)

606SCAT Chrome upper Fishtail muffler (sold each)

606SCAB Chrome lower Fishtail muffler (sold each)

CAMHB Chrome exhaust hanger bracket (sold each)

514L Chrome 5-speed belt guard

COMMON PARTS FOR ALL CAPTAIN BIKES

806CFP Gas tank - painted with flag design

806CF Gas tank - raw steel

800 Gas cap

800AR Petcock

550CA Captain America King/Queen seat

134CA Chrome rear fender

350 Chrome 4-inch tall risers

359D Riser bolts

406 Chrome ignition switch bracket

741A Chrome top motor mount

360A Chrome skid plate



TO ORDER THESE PARTS, CALL US AT 775-246-5738
OR TOLL FREE AT 800-423-2621



105

FRAME ACCESSORIES



AXLE ADJUSTERS FOR HD AND PAUGHCO FRAMES

Stock replacement wheel adjusting screws for HD or Paughco frames. Set of 2 with locknuts.

143 1936-1972 HD frames and all Paughco frames



2001



1103B



1103C

SEAT POST BUSHINGS

1103B For 1936-1957 Big Twins (OEM 47583-36)

1103C For 1929-1973 45" models and Servi-Cars (OEM 47581-29)

VIBRATOR BAR

Ever wonder what those loops on your frame were for? Besides a side car, this is it. It helps keep the early HD frames from falling apart.

2001 Sold each



WELD-ON VIBRATOR BAR KIT

Easy-to-install weld-on kit to add the OEM style lower frame loops and Vibrator Bar back onto stock frames or add them to custom frames. Chrome kit comes with five-piece bar assembly and two raw steel round collars to weld onto frame.

2001W Complete kit



540B

540D

540C

SEAT T-BAR HARDWARE FOR EARLY POGO SEATS

540B Bushing and bolt (OEM 4044, 51925-37)

540C Seat post clevis pin (OEM 51918-29)

540D Clevis pin spring clip (OEM 51920-29)



E165



E166

STOCK REPLACEMENT FENDER STRUTS FOR SOFTAILS

Triple chrome-plated for 5-speed Softails from 1986-1999. They also fit all Paughco 'Easyride' frames with integral frame horns.

E165 Four hole struts for Heritage Softails and Fat Boys. Replaces OEM 59964-86 (right side) and OEM 59969-86 (left side)

E166 Six hole struts for FXST, FXSTC, FXSTS and Bad Boy. Replaces OEM 59955-86 (right side) and OEM 59954-86 (left side)



BOLT-ON RAW STEEL FENDER STRUTS

Paint, powercoat or chrome these struts. They're intended for use with Paughco frames that don't have integral frame horns for OEM-style struts.

FOR STANDARD 'EASYRIDE' FRAMES

E159 For 6"-wide fenders

FOR PAUGHCO WIDE FRAMES

E159W For 7½"-wide fenders

E160W For 8½"-wide fenders

E161W For 9"-wide fenders

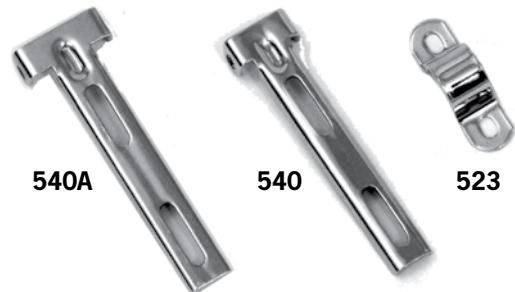

540A

540

523

FENDER CLAMPS AND SEAT BRACKETS

523 Fender clamp for rigid frames (sold each) OEM 59800-36

B523 Same as Paughco #523 but gloss black (not shown)

540 Universal 1¾"-wide seat bracket

540A Universal 2¼"-wide seat bracket



CHAIN GUARDS

TRIKE
KITS

SPRINGERS
& FORKS

HANDLEBARS
& RISERS

LIGHTING

FRAMES &
ACCESSORIES

WHEELS
& BRAKES

GAS & OIL
TANKS

SHEET
METAL

ENGINE &
ELECTRICAL

PRIMARY &
DRIVETRAIN

FOOT
CONTROLS

TRANSMISSION

EXHAUST

TOOLS &
GENERAL

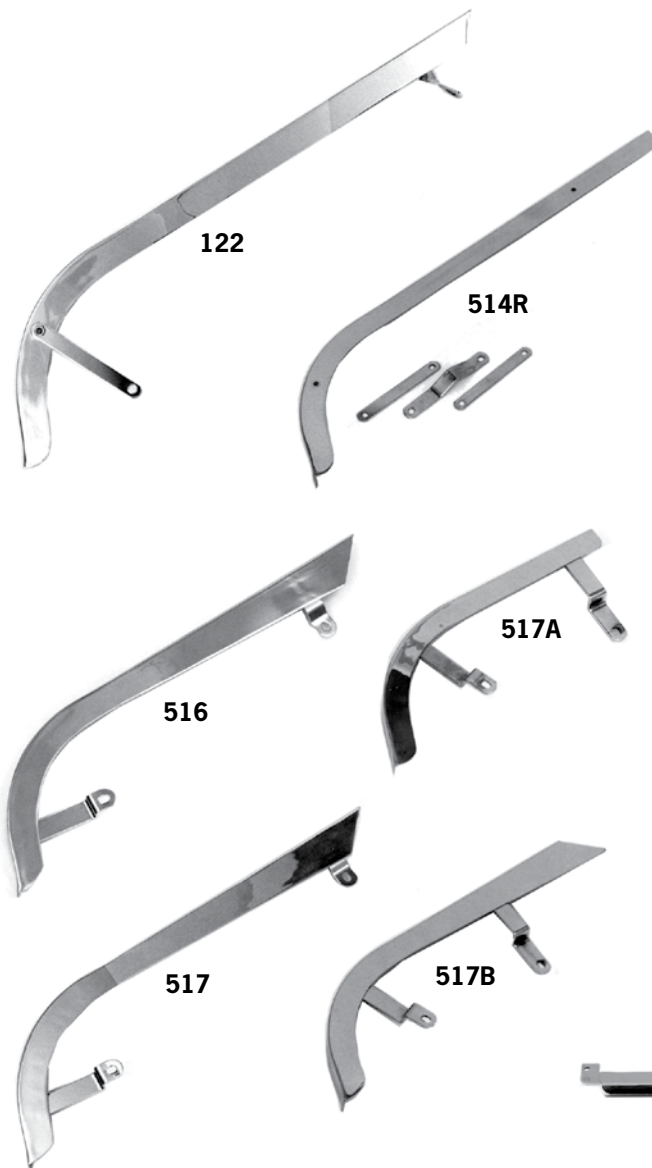

SPORTSTER CHAIN GUARDS FOR RIGID AND SWINGARM FRAMES

- 122** Fits Paughco #120 rigid Sportster frames
- 514R** Right-side universal chain guard with brackets (32½"-long)
- 516** Fits 1956–1971 kickstart XLCH (OEM's 60308-70, 60303-56)
- 517** Fits 1967–1971 electric start XLH models (OEM 60308-67)
- 517A** Fits 1967–1978 XLH and 1970–1978 XLCH electric start models (OEM 60344-72)
- 517B** Fits all 1979–1981 kickstart XL, XLCH and XLS models (OEM 60375-79)

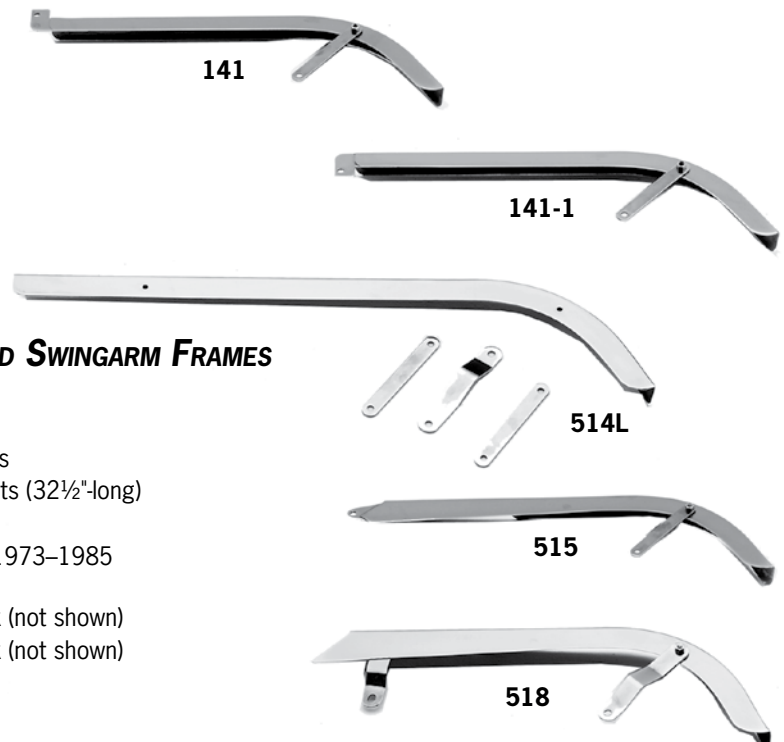

CHAIN GUARDS FOR BIG TWIN RIGID AND SWINGARM FRAMES AND PAUGHCO 'EASYRIDE' FRAMES

- 141** Fits rigid frames with aluminum primaries
- 141-1** Fits 'Easyride' frames with chain final drives
- 514L** Left-side universal chain guard with brackets (32½"-long)
- 515** Fits Paughco or early HD rigid frames
- 518** Fits all 4-speed swingarm Big Twins from 1973–1985 (except Softails)
- B515** Same as Paughco #515 but in gloss black (not shown)
- B518** Same as Paughco #518 but in gloss black (not shown)

TO ORDER THESE PARTS, CALL US AT 775-246-5738
OR TOLL FREE AT 800-423-2621



SHOCK STUDS & FRAME STRUTS



315



319



316



320



317



321



318



323



322



324

SHOCK STUDS FOR BIG TWINS AND SPORTSTERS

Cadmium-plated and sold in pairs.

UPPER SHOCK STUDS

- 322** Fits 1958–1966 Big Twins (OEM 54515-58A)
- 315** Fits 1967–1972 Big Twins (OEM 54515-67)
- 317** Fits 1973–1986 Big Twins (OEM 54515-73)
- 316** Fits 1956–1974 Sportsters (OEM 54515-56B)
- 318** Fits 1975–1978 Sportsters (OEM 54515-75)
- 319-1** Fits 1975–1978 Sportsters. Special studs for use with 1/2" hole replacement struts (Paughco #'s 313A, 313C, and 313D). Will not work with shocks

LOWER SHOCK STUDS

- 321** Fits 1958–1965 Big Twins (OEM 54517-58)
- 323** Fits 1965–1967 Big Twins (OEM 54517-65)
- 324** Fits 1967–1972 Big Twins (OEM 54517-67)
- 320** Fits 1956–1974 Sportsters (OEM 54516-72)
- 319** Fits 1975–1978 Sportsters (OEM 54516-75)



313

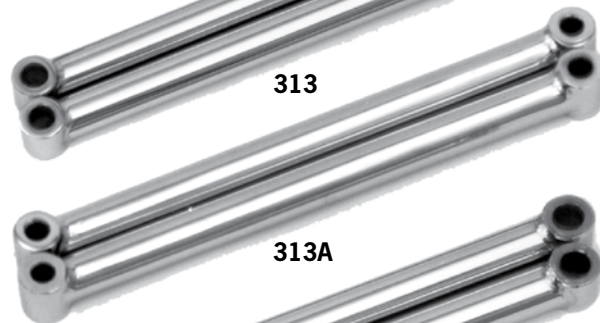

313A

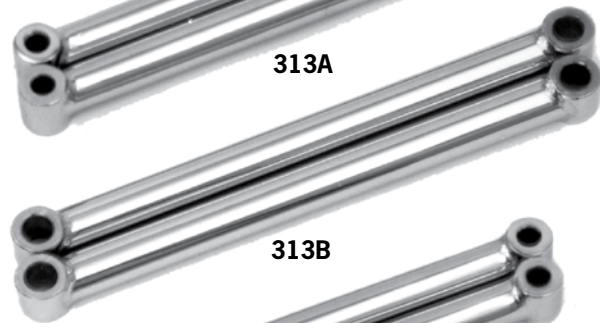

313B

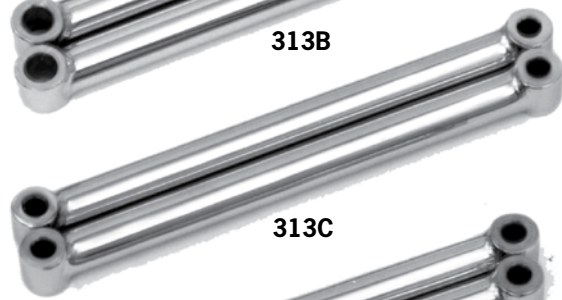

313C

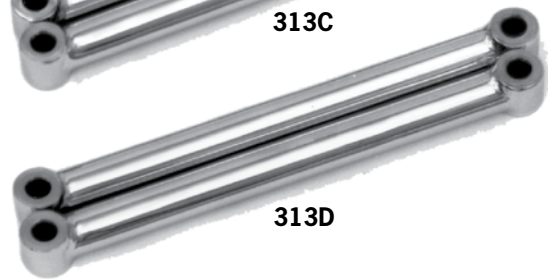

313D

CHROME REPLACEMENT STRUTS FOR BIG TWIN AND SPORTSTER SWINGARM FRAMES

Replaces the shocks on swingarm Big Twin and Sportster frames. They are required to provide the necessary clearance for the rear pipe on some swingarm Sportster exhaust sets (Paughco #'s 719B2, 719B2AS, 719B2FS and 719B2SS).

REPLACEMENT STRUTS FOR EARLY MODELS

Replaces shocks on early model Big Twins and stock 1957–1974 swingarm Sportster frames. Use with shock studs #316 and #320 to install (see elsewhere on this page).

- 313** 12" eye-to-eye with 5/8" hole diameters
- 313B** 13" eye-to-eye with 5/8" hole diameters

REPLACEMENT STRUTS FOR LATE MODELS

Replaces shocks on late model Big Twins and stock 1975–1978 swingarm Sportster frames. On Big Twins, mount these struts with the year-appropriate studs (see elsewhere on this page). On Sportsters, mount these struts with one pair of Paughco #319 lower shock studs and one pair of Paughco #319-1 upper shock studs (see elsewhere on this page).

- 313A** 13" eye-to-eye with 1/2" hole diameters
- 313C** 12" eye-to-eye with 1/2" hole diameters
- 313D** 11" eye-to-eye with 1/2" hole diameters

