

VISION Island Freezer

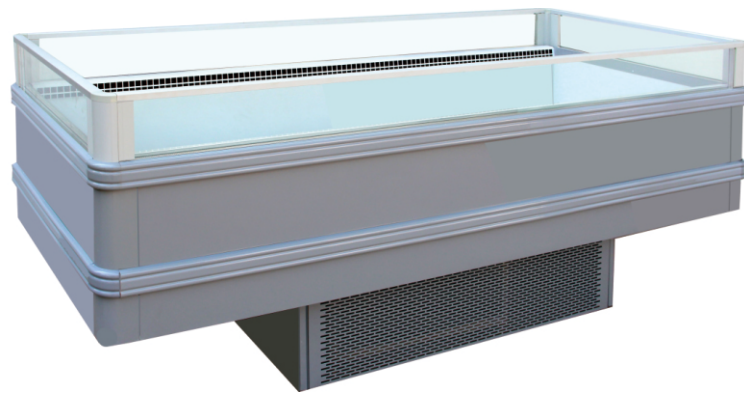

Standard features

- Freezer and Fridge interchangeable with switch
- Ventilated cooling system
- Self-contained Secop compressor with R290 gas, plug in for use
- Carel digital thermostat for accurate control of cabinet temperature
- Auto defrosting and with self-evaporation water tray
- Top sliding glass door optional
- Custom color

Specifications:

Model	VISION 150	VISION 200	VISION 250
Exterior Dimensions	1613*1078*980 mm	2113*1078*980 mm	2613*1078*980 mm
Display Area	1.03 m ²	1.4 m ²	1.78 m ²
Temperature	-1 / +5 or -18 / -22°C		
Climate Class	3	3	3
Net Volume	260 L	350 L	440 L
Cooling System	Ventilated	Ventilated	Ventilated
Refrigerant	R290	R290	R290
Voltage/Frequency	220-240V, 60Hz	220-240V, 60Hz	220-240V, 60Hz
Input Power	1236 W	1661 W	2156 W
Rated Current	7.2 A	8.6 A	10.5 A
Power Consumption	12.1 KWH/24H	15.3 KWH/24H	18.7 KWH/24H
Compressor	SECOP SCE15CNLX X2	SECOP SC18CNLX.2 X2	SECOP SC21CNLX.2 X2
Thermostat	Carel	Carel	Carel
Condenser Fan Motor	EBM	EBM	EBM
Body Material	Powder Coated Galvanized Steel		
Net Weight	150 KGS	190 KGS	250 KGS
Gross Weight	170 KGS	215 KGS	280 KGS

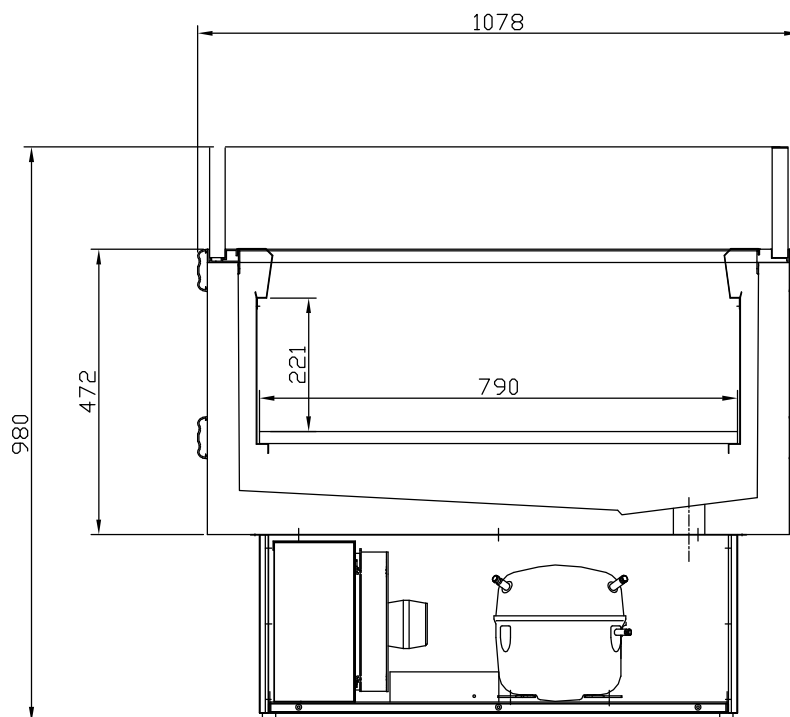

Electric diagram

