

CHEST FREEZER



BD-550A



BD-550SS



Features

- European super low energy consumption A+
- 75mm thickness insulation
- Suitable for wide climate, SN/T
- Adjustable thermostat
- Main power indicator
- Defrost water drain hole
- External handle with lock
- Adjustable feet
- Environmentally friendly

Options

- Interior LED light/outside Condensor/ Caster wheels/ full baskets/digital thermometer/top SS lid

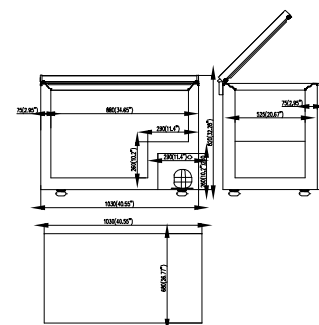

BD-350

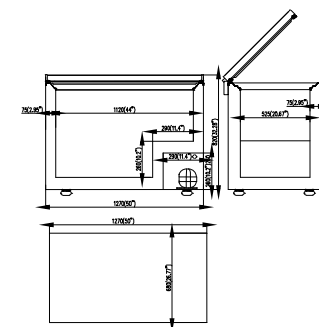

BD-450

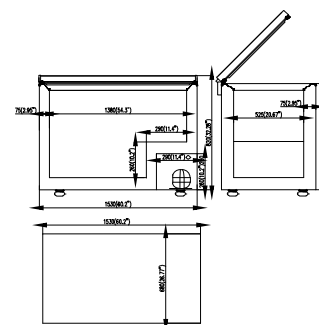

BD-550

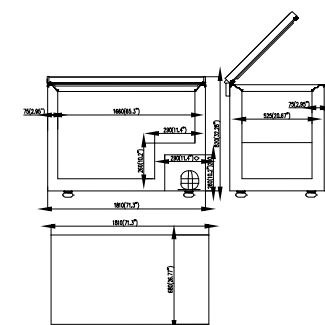

BD-650

| Product Model | BD-350 | BD-450 | BD-550 | BD-650 |
|------------------------------|--------------|--------------|--------------|--------------|
| Unit Dimension (W/D/H mm) | 1030*755*840 | 1270*755*840 | 1530*755*840 | 1810*755*840 |
| Packing Dimension (W/D/H mm) | 1080*780*890 | 1320*780*890 | 1580*780*890 | 1860*780*890 |
| Net capacity (L) | 272 | 358 | 450 | 550 |
| Cooling system | Static | Static | Static | Static |
| Foaming thickness (mm) | 75 | 75 | 75 | 75 |
| Climate | SN/T | SN/T | SN/T | SN/T |
| Energy class | A+ | A+ | A+ | A+ |
| Temperature (°C) | ≤-18 | ≤-18 | ≤-18 | ≤-18 |
| Basket No. | 1 | 1 | 2 | 2 |
| Kind of coolant | R600a | R600a | R600a | R600a |