

# 72" CHEF Combined Island Freezer with Sliding Glass Top CQS-18D



CQS-18D

## Features

- Super size straight line Island freezer
- Exterior material: white pre-coated steel, Interior white pre-painted aluminium sheet
- Top curved sliding glass lid with low-E film
- Automatic hot gas defrost
- Condensing with fan
- High quality danfoss compressor
- Italian brand Eliwell/Dixell digital thermostat
- Interior LED light
- Full Basket with dividers
- Front side protection pole
- Adjustable feet
- Caster wheels

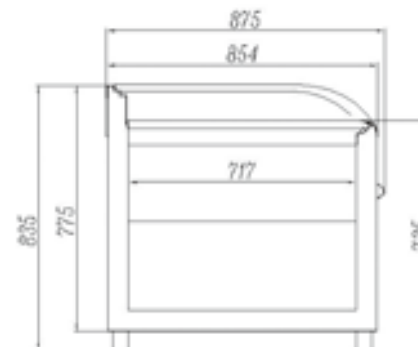

Product Model	CQS-18D		
Unit Dimensions (W/D/H mm)	1860*854*835		
Pack Dimensions (W / D/ H mm)	1940*1040*870		
Net capacity (L)	400		
Defrost system	Automatic		
Temperature (°C)	3L1		
Baskets divider	3+1		
Interior light	LED Light		
Compressor	Embraco/Secop		
Digital thermostat	Eliwell/Dixell		
Kind of coolant	R404A/R290		
Power	220V/1Ph/60hz/13Amp		