



Equipment for the Foodservice Industry

value + quality + service

Work Top Refrigeration

CWDR3-72VC



CWDR3-72VC

Features

Features:

- Exterior & interior stainless steel construction
- Environmentally friendly R290 refrigerant
- Heavy duty Embraco compressor
- Self-closing and stay open door
- Efficient refrigeration system
- Recessed door handle
- Removable gasket that is easy to clean and replace
- Casters for easy movement
- Pre-installed shelves

Warranty:

- Two year parts and labour; Five years on compressor. *For full warranty details visit <https://www.efifoodequip.com/warranty-info.php>*



CWDR3-72VC Specifications

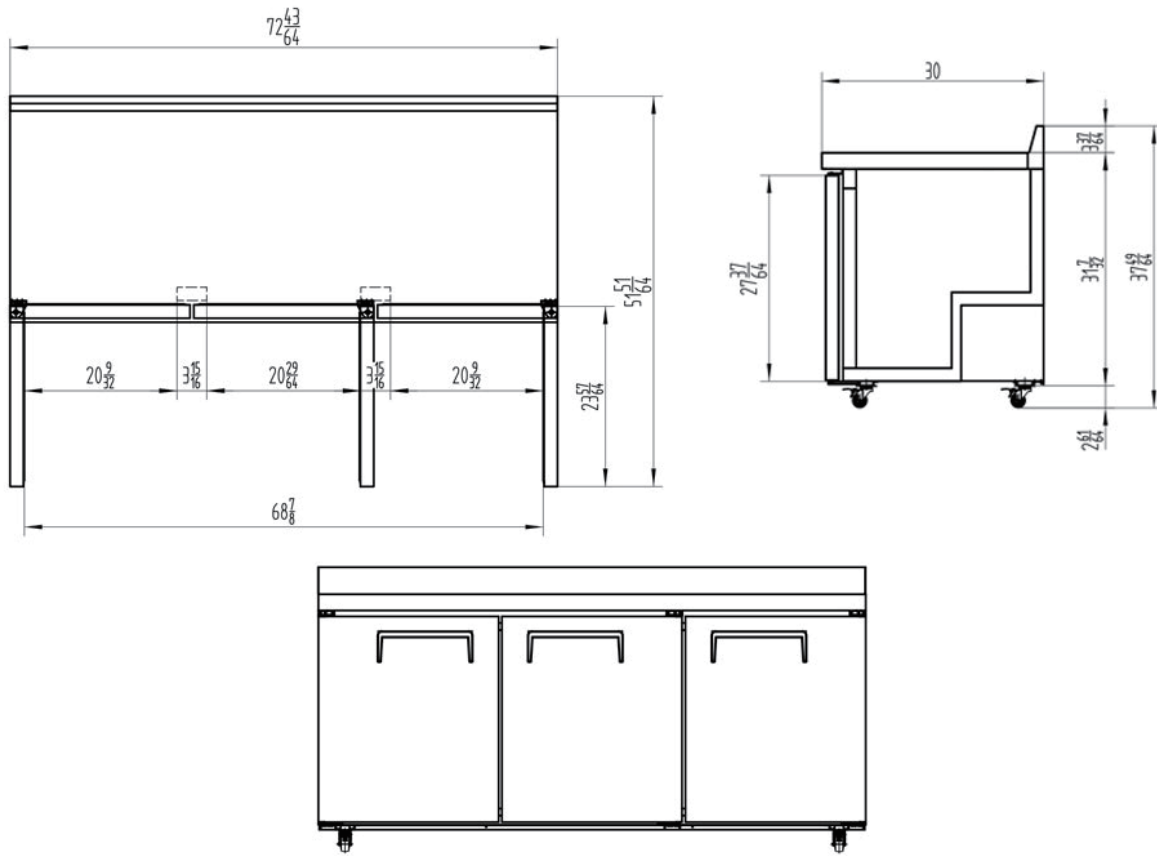

Model	Refrigerant	Doors	Shelves	Dimension (mm) (inch)			HP	Voltage	Amps	Capacity (L) (Cu Ft.)	Net Weight (KG) (LBS)	Temperature Range
				L	D	H						
CWDR3-72VC	R290	3	3	1846	762	995	1/5	115/60	2.8	598	118	1 ~ 8°C
				72.7	30.0	39.2						21.1

Equipped with one NEMA 5-15P plug

Shipping Information

Crate Dimensions (mm) (inch)			Net Weight (KG) (LBS)	Gross Weight (KG) (LBS)
L	D	H		
1900	831	1077	123	150
74.8	32.7	42.4	254	330

Specifications subject to change without notice.