

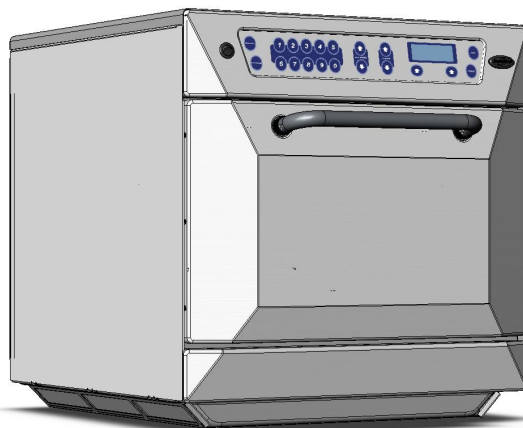

Version 3.0



Version 2.0

 **Merrychef**

402s

US Models including WAWA

SERVICE & PARTS MANUAL

This manual covers US models manufactured from:

Version 2.0 Serial No. 000745 –001199

Version 3.0 Serial No. 001200 onwards

ISSUE 6

18.03.2008

CAUTION MICROWAVE EMISSIONS

**DO NOT BECOME EXPOSED TO EMISSIONS FROM THE MICROWAVE
GENERATOR OR PARTS CONDUCTING MICROWAVE ENERGY**

SERVICE MANUAL

TABLE OF CONTENTS

Microwave safety precautions	3
Safety code	4
Product specifications	5
Installation instructions	6
Main features	7- 9
Principal components: RHS	10
Principal components: LHS	11
Principal components: Top	12
Principal components: Back View.....	13
Principal components: Power Supply	14
Principal components: Cavity Parts	15
Principal components: External Panels	16
Principal components: Control Panel.....	17
Parts Matrix.....	18-19
Procedure for Microwave Emission test	20-21
Procedure for Power output measurement.....	22
Procedures for Principal Component tests	23-24
Procedure for door interlock adjustment.....	25-26
Hot Air Motor and controller.....	27-28
Wiring Diagrams	29
Trouble Shooting Guide.....	30-34
Appendix 1: Temperature Probe.....	35
Appendix 2: MenuKey Procedures	36-37
Appendix 3: Cleaning Procedure	38-40
Appendix 4: Recommended Spares List	41-42
Appendix 5: PCB connection Points.....	43-44
Appendix 6: Engineering Test Settings.....	45
Appendix 7: Firmware revision guide.....	46-51

Merrychef USA
1111 North Hadley RD
Fort Wayne
IN 46804

Phone: 800/678 - 9511 Fax: 800/285 - 9511
e-mail: info@merrychefusa.com

MICROWAVE SAFETY PRECAUTIONS

CAUTION WARNING TO SERVICE TECHNICIANS PRECAUTIONS TO BE OBSERVED BEFORE AND DURING SERVICING TO AVOID POSSIBLE EXPOSURE TO EXCESSIVE MICROWAVE ENERGY

- (a) Do not operate or allow the oven to be operated with the door open.
- (b) Make the following safety checks on all ovens to be serviced before activating the magnetron or other microwave source, and make repairs as necessary:
 - 1) interlock operation.
 - 2) proper door closing.
 - 3) seal and sealing surfaces (arcing, wear, and other damage).
 - 4) damage to or loosening of hinges and latches.
 - 5) evidence of dropping or abuse.
- (c) Before turning on microwave power for any service test or inspection within the microwave generating compartments, check the magnetron, wave guide or transmission line, and cavity for proper alignment, integrity and connections.
- (d) Any defective or misadjusted components in the interlock, monitor, door seal, and microwave generation and transmission systems shall be repaired, replaced, or adjusted by procedures described in this manual before the oven is released to the owner.
- (e)(i) For U.S.A.
A microwave leakage check to verify compliance with the Federal Performance Standard should be performed on each oven prior to release to the owner.
- (e)(ii) For CANADA.
A microwave leakage check to verify compliance with the Canadian Regulation, HEALTH AND WELFARE, SOR/79 920 should be performed on each oven prior to release to the owner.

SAFETY CODE

This manual is designed to assist engineers who have been on a recognised product familiarisation and training course run by Merrychef. It has been prepared to offer technical guidance for the 402s range of Ovens.

Please remember that it is wiser **not** to attempt a service task if you are unsure of being able to complete it competently, quickly, and above all **safely**.

To avoid injury to yourself, and to protect the appliance from possible damage, please follow this Safety Code when servicing these ovens.

Before attempting to repair the oven, check it for microwave emission using a calibrated emission detector.

Check that the oven is not emitting microwaves, even when supposedly not in operation.

Check that the oven is not operating continuously, whether the display indicates cooking or not.

Always discharge the HT capacitors before working on the oven using a suitably insulated 10 M Ω Resistor.

When testing the oven with covers off run for short periods of time only or magnetrons will overheat and the display will show Error condition.

Before removing any covers from the oven, do all of the following.

- Switch off the mains supply and remove the plug from the wall socket.
or
- If the oven is hard wired, ensure that the power is turned off at the isolator switch.

Note:

The On/Off switch on the oven is **not** adequate protection against electric shock, as it does not isolate all of the internal wiring from the mains.

Upon completion of a service the oven, or before reconnecting the appliance to the electrical supply for testing, check all of the following points:

- All internal electrical connections are correct (see wiring diagrams).
- All wiring insulation is correct and is not touching a sharp edge.
- All grounding connections are electrically and mechanically secure.
- All door safety interlocks are secure and mechanically sound.
- The door operation is smooth, and the arms run freely in the slots.
- The door activates all four of the door interlock switches and **in the correct order**
- The temperature sensor is correctly connected to the Power PCB.

Before finishing a service call, recheck the following points:

- All of the electronics are functioning correctly and all of the touch pads are working.
- Microwave emissions are below permissible limit of 4 mW/cm².
- The power output of the oven is checked in accordance with the procedure page.
- Oven has correct 2 inch (50mm) air gap all round and 2 inches (50mm) above. Air flow should not be restricted.

PRODUCT SPECIFICATIONS

Model Number: 402S VVV F P C R TT ZZ

Example 402S2086DK3GMUS

Model No. EC402s

208V, 60Hz, 2P + GND supply, MenuKey Revision 3, General Market, USA

Supply Voltage	Freq. Hz	Phase/Supply	Control Type	Rev	Type	Country /Region
VVV	F	P	C	R	TT	ZZ
Voltage (ac) 208 = 208V 220 = 220-230V 240 = 230-240V	5 = 50Hz 6 = 60Hz	Phase Arrangement A = L + N + E (30 Amp) B = L1 + L2 + N + E C = 2 P + Gnd (20 Amps) D = 2 P + Gnd (30 Amps)	K = Electronic MenuKey	1 2 3	GM = General Market	US = USA

Power Requirements	208Volts 240Volts	208V ac 60Hz 30Amp 2P & G 240V ac 60Hz 40Amp 2P & G
Power Output	Microwave 100% Convection	1500watts 3250watts
External Dimensions	Height Width Depth	23.0 inches 23.0 inches 27.5 inches
Weight	Nett	198lb.s (90kg)
Construction	Cavity Casework	304 Stainless Steel

INSTALLATION INSTRUCTIONS

Installation Instructions for Mealstream Combination Ovens

Power Supply Requirements

The Mealstream Series should be connected to a suitable electricity supply, which can cope with the switching-on surge that occurs with certain types of catering equipment, including microwaves. Because of this requirement, we strongly recommend that a separate, suitably rated supply is installed for the oven.

The supply for the oven should be fitted with a **Type "C"** or **Time Delay circuit breaker**.

If the oven is hard-wired to the supply, a double-pole isolator switch with a contact gap of at least 1/8 inch (3 mm) should be fitted.

Grounding requirement

This appliance must be connected to a grounded, metallic, permanent wiring system, or an equipment grounding conductor should be run with the circuit conductors and connected to the equipment grounding terminal or lead on the appliance.

Positioning the Oven

In order to maintain adequate ventilation for air intake and exhaust, and to allow access for cleaning filters, you must allow a minimum of 2 inches (50 mm) clearance at the sides and rear of the oven.

Air intake temperature should not exceed 110°F/45°C excessive temperature will lead to reduced operating duty cycle, or premature ageing of internal components. Failure to comply with these conditions will invalidate the warranty.

NEVER Install an oven above fryers, grills, griddles or any other major heat source.

ALWAYS Place containers in the cavity carefully - impact damage may chip the vitreous enamel coating on the runners and baffle plate.

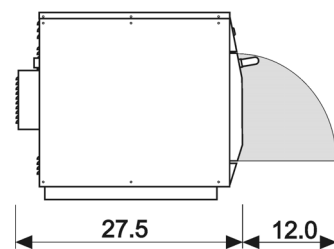
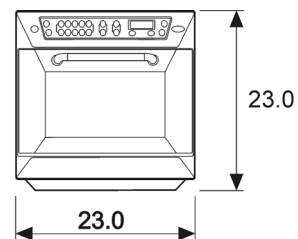

Note:
The minimum recommended clearance required for air flow

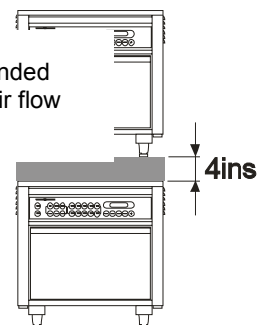

MAIN FEATURES

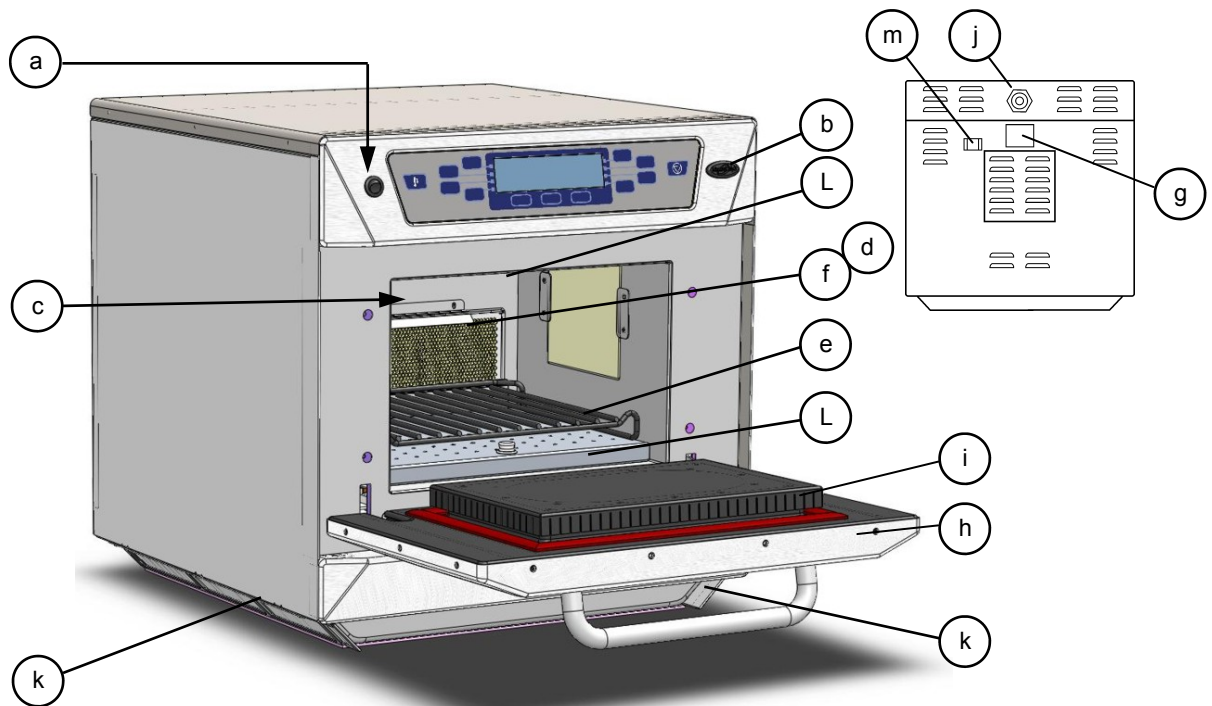

a On/Off SWITCH

This is used to turn the oven On or Off.

IT DOES NOT ISOLATE INTERNAL WIRING FROM THE MAINS SUPPLY.

b MenuKey

The MenuKey System automatically changes all the cooking programs with an electronic key and allows program names to be identified.

c OVEN CAVITY

The oven cavity is mainly constructed from stainless steel panels. It must be kept clean.

d GREASE FILTER

The grease filter must be cleaned on a regular basis, and kept free of debris.

e RACK

The cooking rack should be removed daily and cleaned

f HOT AIR FAN

Situated behind the grease filter and circulates the hot air through the cavity.

g RATING PLATE

The rating plate is situated on the rear of the oven, and states the Model, Serial Number, Electrical Ratings and Manufacturers telephone number.

h DOOR

The door consists of a thermally insulated inner section, and an additional air gap provided by a twin skinned door front to lower the surface temperature.

i DOOR SEAL

These ensure a tight seal around the door. They should be kept clean and checked regularly for signs of damage. Replace if worn or damaged.

j ELECTRICAL SUPPLY CORD

Electrical supply cord is situated on the rear of the oven,

k AIR FILTERS

Main intake for cooling air for internal components. Must be clear of obstructions.

L IMPINGER PLATES (Upper & Lower)

Direct the air in the cavity. They must be cleaned on a regular basis, and kept free of debris

m STEAM VENT PIPE

Vents steam from the oven cavity

MAIN FEATURES

Electronic control panel: Version 2.0

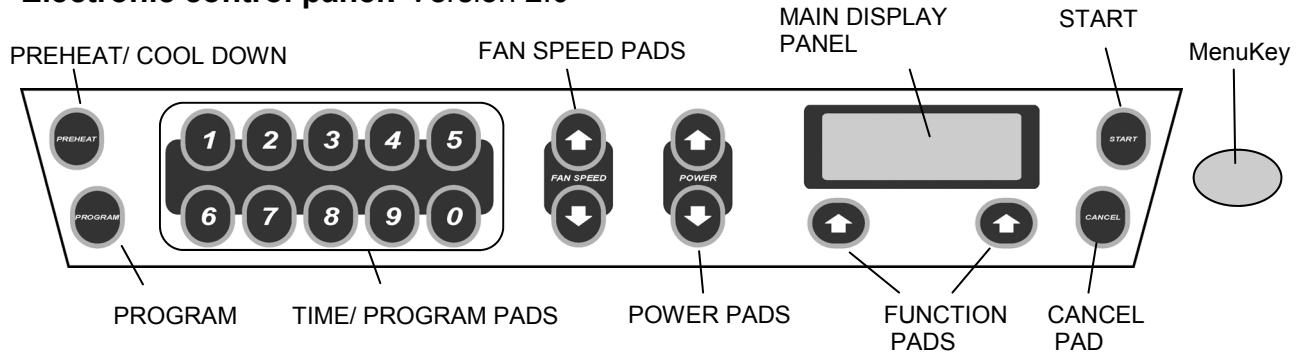

CANCEL PAD

Cancels all timed cooking cycles, pre-programmed operations and stops the microwave energy. It does not alter the oven temperature. If the oven is hot, food will continue to cook and should be removed from the oven immediately. This pad will also cancel any incorrect operations. It will not erase programs.

FAN SPEED PADS

The Fan speed can be increased and decreased in 5% steps (10% to 100%)

FUNCTION PADS

Move through control functions in the Main Display

MAIN DISPLAY PANEL

Shows the principal functions of the oven.
When cooking, the time remaining counts down.
Also displays error messages and oven temperature.
(See TROUBLESHOOTING)
When storing and recalling a program the display indicates the program number and details

MenuKey

The MenuKey System automatically changes all the cooking programs with an electronic key and allows program names to be identified.

POWER PADS

The microwave power can be increased or decreased adjusted in 10% steps. (0% to 100%)
The default setting is 50% microwave power.

PREHEAT/ COOL DOWN

Commences main oven heating cycle to a preset temperature. Press and hold for 5 seconds to commence cool down procedure (See CLEANING)

PROGRAM

Activates program mode for storing programs in memory START PAD Commences a program

TIME/ PROGRAM PADS

These pads are used for setting the cooking time in 1 second steps to a maximum of 10 minutes.
They are also used for storing and recalling programs from 0-499

Display Panel error messages

Message	Condition	Possible cause
ERROR MAGNETRON 1	Magnetron 1 has overheated	Blocked Air filter(s) Oven located near hot air sources Oven being used empty Cooling fan failure Magnetron failure
ERROR MAGNETRON 2	Magnetron 2 has overheated	
ERROR MAGNETRON 1 & 2	Magnetron 1 and 2 have overheated	
CAVITY SENSOR ERROR	Cavity temperature exceeds more than 90°F above PREHEAT temperature setting during cook cycle	Indicates combustion (fire) in oven cavity Note: In service operations when PREHEAT is set to 0°F this message can appear when the oven is operated

MAIN FEATURES

Electronic control panel: Version 3.0

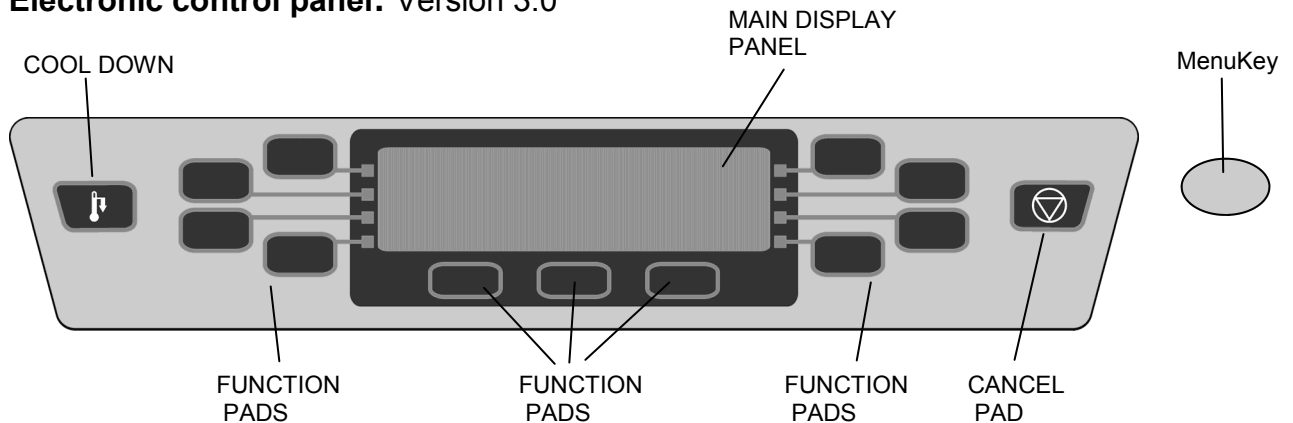

MenuKey 2

The MenuKey System automatically changes all the cooking programs with an electronic key and allows program names to be identified

CANCEL PAD

Cancels all timed cooking cycles, pre-programmed operations and stops the microwave energy. It does not alter the oven temperature. If the oven is hot, food will continue to cook and should be removed from the oven immediately. This pad will also cancel any incorrect operations. It will not erase programs.

DISPLAY PANEL

Shows the principal functions of the oven. When cooking, the time remaining counts down. Also displays error messages and oven temperature. When storing and recalling a program the display indicates the program number and details.

FUNCTION PADS

The function pads select options shown in the DISPLAY PANEL.

COOL DOWN PAD

Puts the oven into Cool Down Mode prior to cleaning

Error Message	Condition	Possible Cause
Magnetron 1 Overheat	Magnetron 1 has overheated	Blocked air filters Ensure air filters are clean Oven located near hot air source Oven being used empty Cooling fan failure Magnetron failure Allow oven to cool
Magnetron 2 Overheat	Magnetron 2 has overheated	
Magnetron 1 & 2 Overheat	Magnetron 1 & 2 have overheated	
Magnetron 1 FAILED	Magnetron 1 failed	No microwave output check power supply
Magnetron 2 FAILED	Magnetron 2 failed	No microwave output check power supply
Ambient Overheat	Temperature inside casing has exceeded limit	Blocked air filters Restricted airflow to air filters Oven located near hot air source Circulation fan failure Combustion (fire) in cavity
Cavity Overheat	Cavity temperature has exceeded more than 565°F	Blocked air filters Restricted airflow to air filters Combustion (fire) in cavity
Heater Failure	Cavity has not reached a temperature of 100°F in 10 minutes	One or more heater elements have failed and need to be replaced

PRINCIPAL COMPONENTS: Right Side

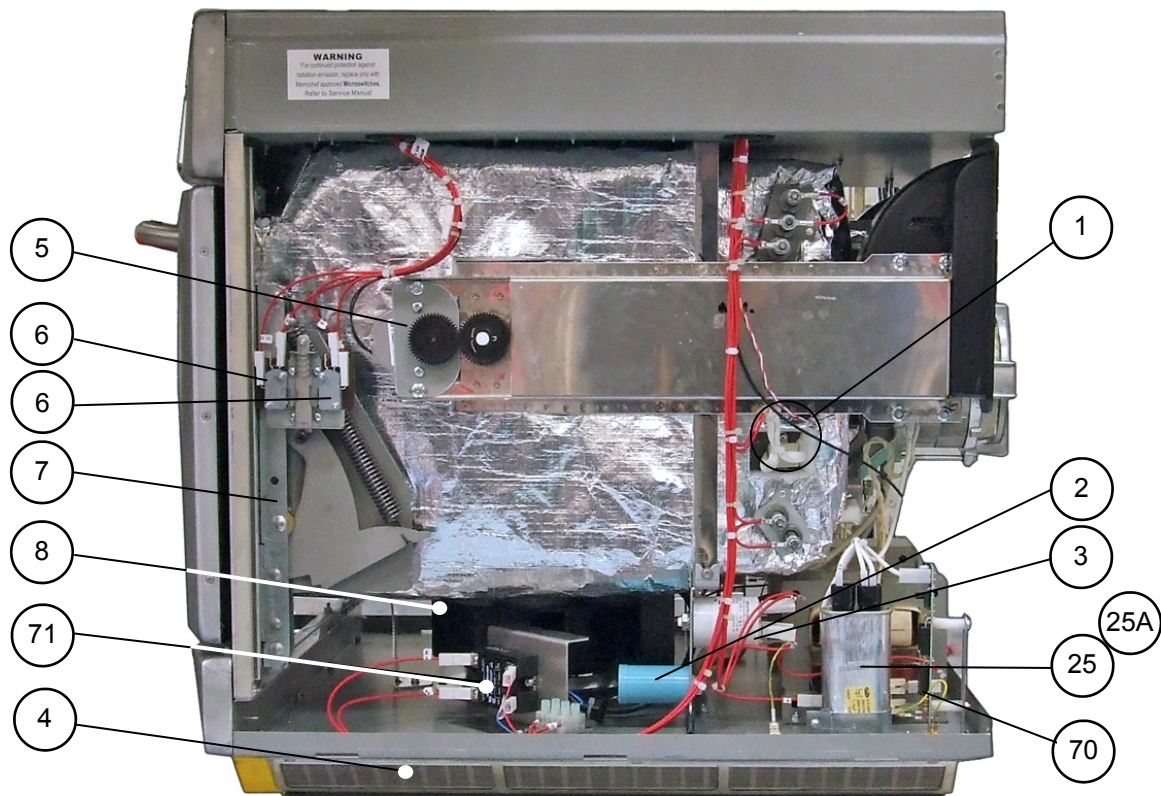

No.	Description	Part No.
1	Cavity High limit Stat	30Z1024
2	Motor Start Capacitor 2 μ F (Blue)	30Z1298
3	Filter 16A	30Z1340
4	Air filter	SA276
5	Stirrer motor Assembly	SA288
5A	Stirrer (inside cavity)	SA291
5B	Stirrer Gear	DV0552
6	Microswitch SW1 Microswitch SW2	30Z1294
6A	Microswitch Assembly	SA212
7	Door Hinge Assembly RH	SA202
8	Magnetron Cooling Fan	30Z1295
25	HV Capacitor 2500V 0.88 μ F (60HZ models)	30Z1251
25A	HV Capacitor clip	31Z1261
70	Fibre Optic Diode Board	11M0364
71	Solid State Relay	30Z1362

PRINCIPAL COMPONENTS: Left Side

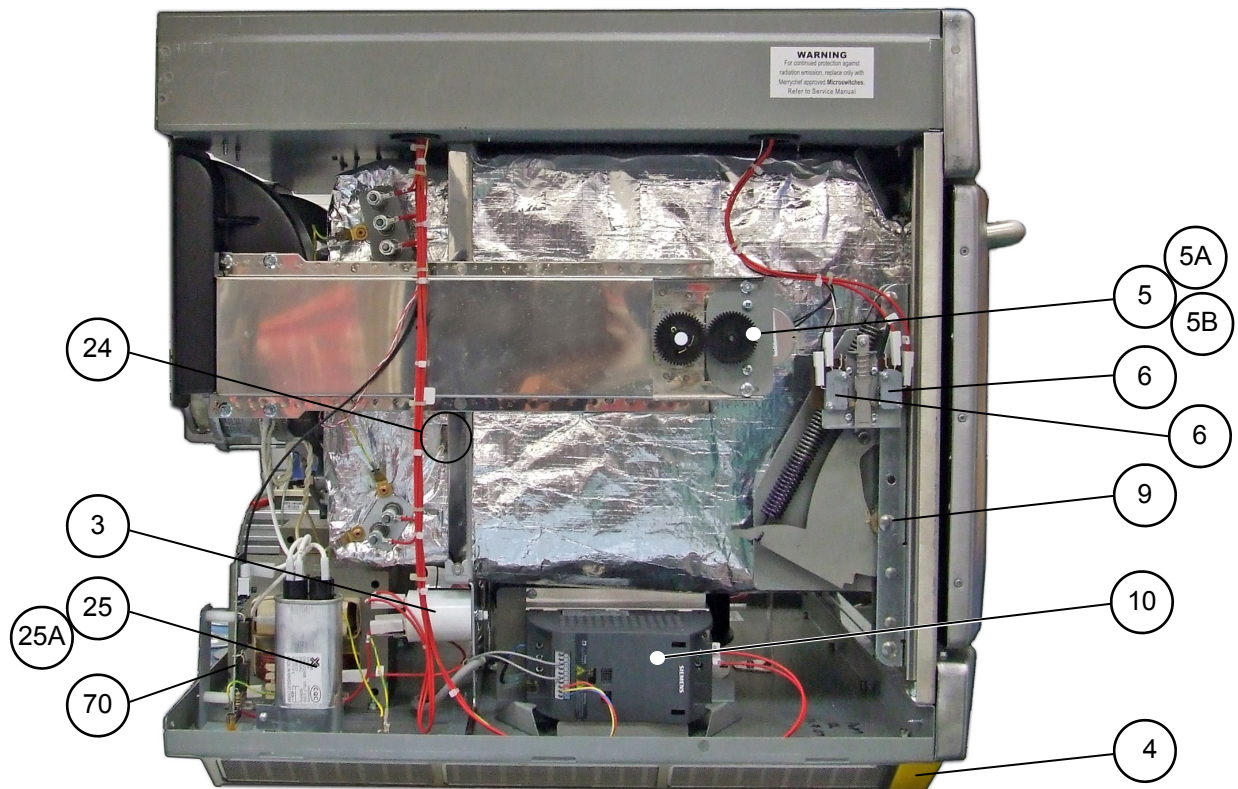

No.	Description	Part No.
3	Filter 16A	30Z1340
4	Air filter	SA276
5	Stirrer motor Assembly	SA288
5A	Stirrer (inside cavity)	SA291
5B	Stirrer Gear	DV0552
6	Microswitch SW3 Microswitch SW4	30Z1294
6A	Microswitch Assembly	SA212
9	Door Hinge Assembly LH	SA203
10	Motor Controller	30Z1293
25	HV Capacitor 2500V 0.88 μ F (60Hz models)	30Z1251
25A	HV Capacitor clip	31Z1261
70	Fibre Optic Diode Board	11M0364

PRINCIPAL COMPONENTS: Control Box

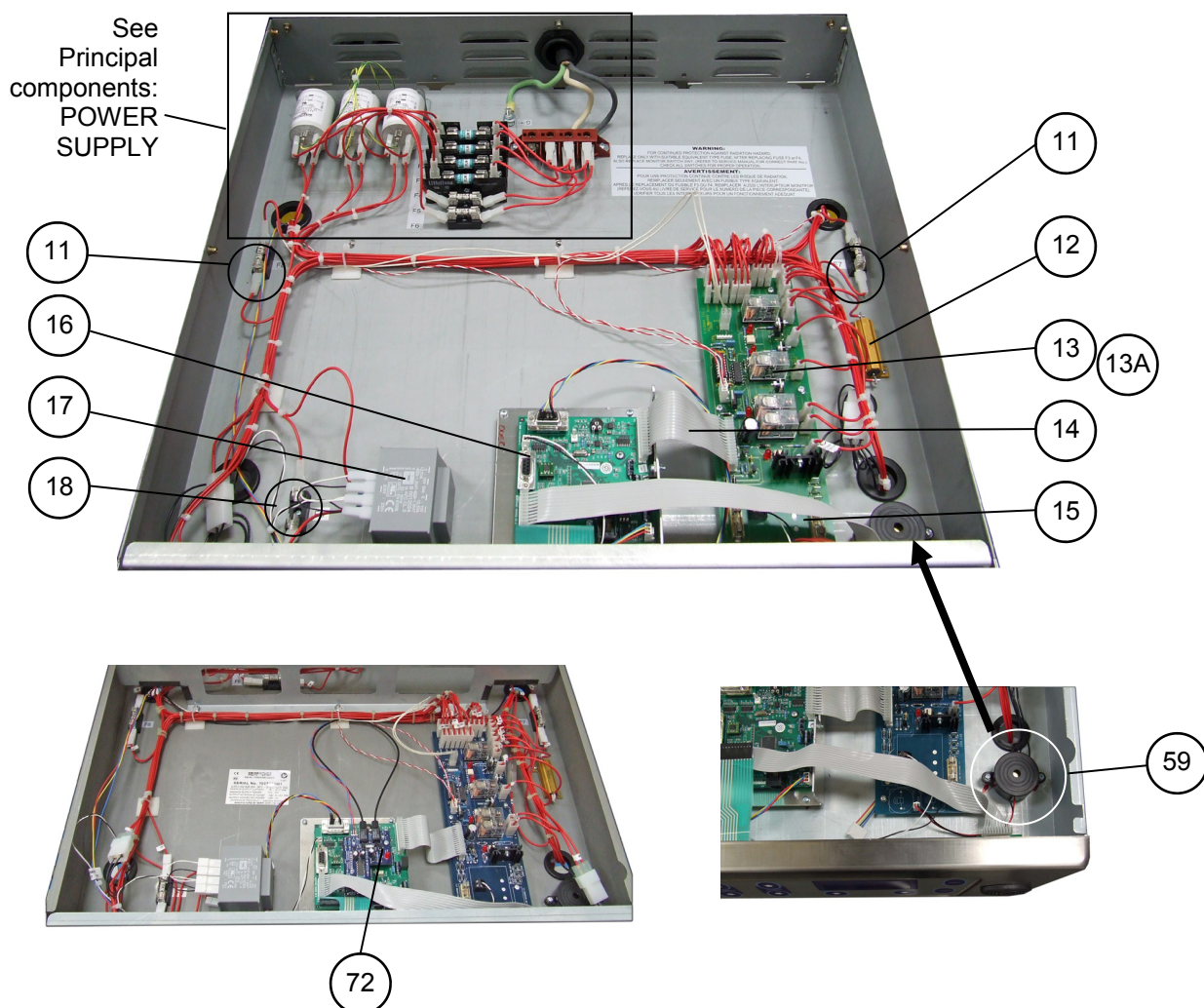

No.	Description	Part No.
11	Fuse 10A HRC	30Z0217
12	Gold resistor (220R)	30Z0235
13	Relay PCB Assembly	11K0004
14	Ribbon Cable 15way	11Z0298
15	Ribbon Cable 10way MenuKey	11M0117
16	Logic PCB Assembly Version 2.0	SA231
16	Logic PCB Assembly Version 3.0	SA260
17	Transformer LT (Low voltage)	30Z1155
18	Fuse 1A	30Z0957
59	Sounder	SA257
72	Fibre Optic Logic PCB	11K0013
75	Relay PCB Fuse	30Z0470

PRINCIPAL COMPONENTS: Back view

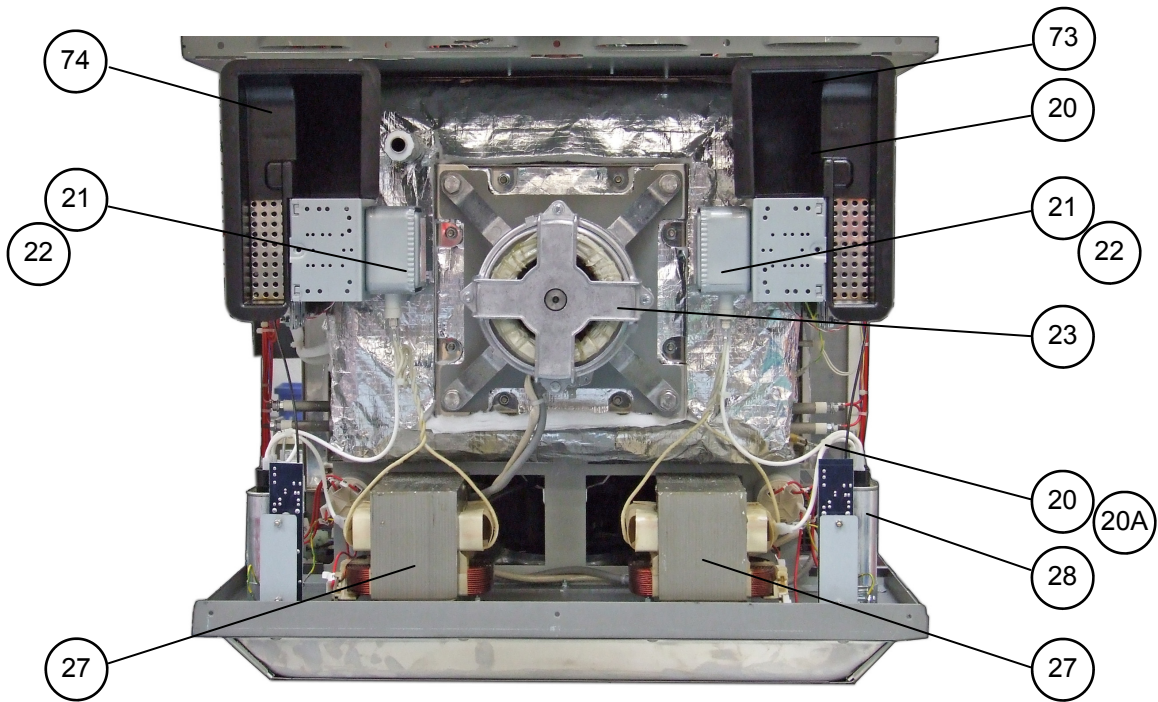

No.	Description	Part No.
20	Heater Element 208V 650W 68Ω	DV0328
20	Heater Element 240V 650W 88Ω	DV0337
20A	Heater Element Collar	DV0058
21	Magnetron	30Z1349
22	Magnetron Thermistor Assembly (Each magnetron)	SA234
23	Convection (Hot Air) Motor Assembly	SA208
24	Thermistor Cavity	30Z1315
27	Transformer 208/220/240V 60Hz	30Z1230
28	HT Rectifier (No Fibre Optic)	11H0010
73	Magnetron Cooling Duct LH	DV0039
74	Magnetron Cooling Duct RH	DV0040

PRINCIPAL COMPONENTS: Power Supply

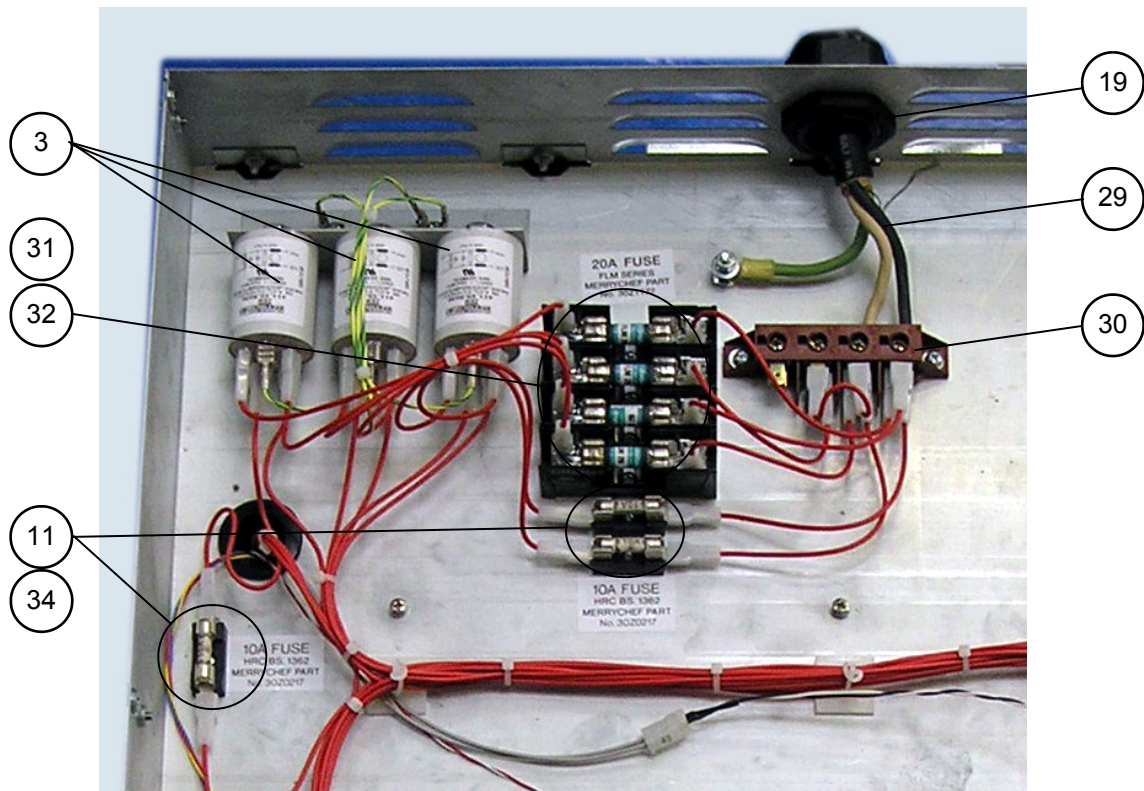

No.	Description	Part No.
3	Filter 16A	30Z1340
11	Fuse 10A HRC	30Z0217
19	Cable Gland	31Z0500
19	Cable Gland Nut	31Z0499
29	Electrical Supply Lead Assembly	SA217
30	Terminal Block	31Z0447
31	Fuse 20A FLM	30Z1177
32	Fuse Holder 30A	30Z1178
34	Fuse Holder 10A	30Z0231

PRINCIPAL COMPONENTS

Cavity parts

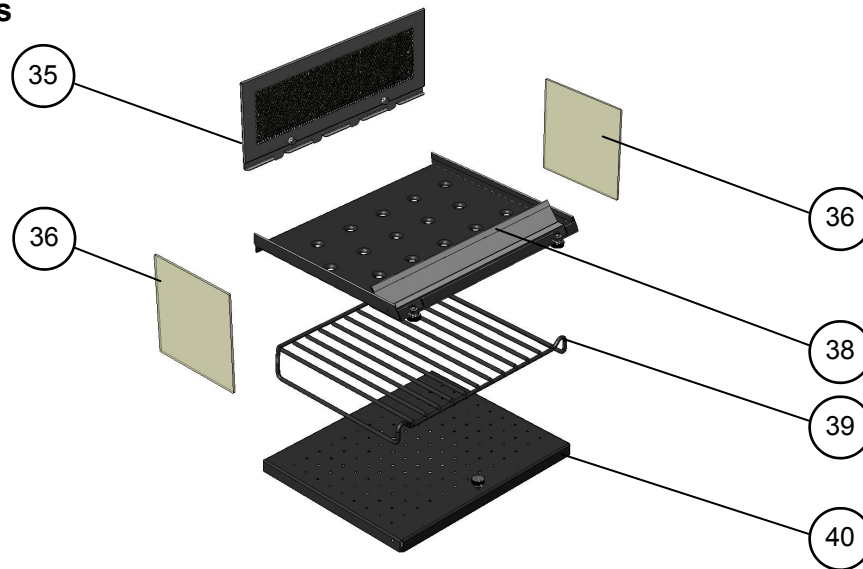

No.	Description	Part No.
35*	Grease Filter Cartridge Filter Housing	SA340 SA339
36	Stirrer Glass	DV0492
37*	Rack Support V2.5 (Not shown)	DV0114
38	Upper Impinger plate	SA211
39	Rack V3.0 Rack V2.5	DV0275 DV0158
40	Lower Impinger plate	SA266

* Parts 35 & 37 Contact Service Department

KFC Accessories

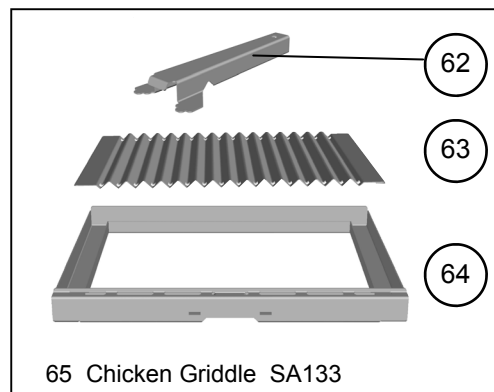

No.	Description	Part No.
60	Cool-down pan	32Z4028
61	Oven tray	MC3175
62	Handle	SA267
63	Griddle	DV0221
64	Griddle carrier	SA350
65	Chicken Griddle (SA350 + DV0221 + DV0267)	SA133

PRINCIPAL COMPONENTS

External Parts

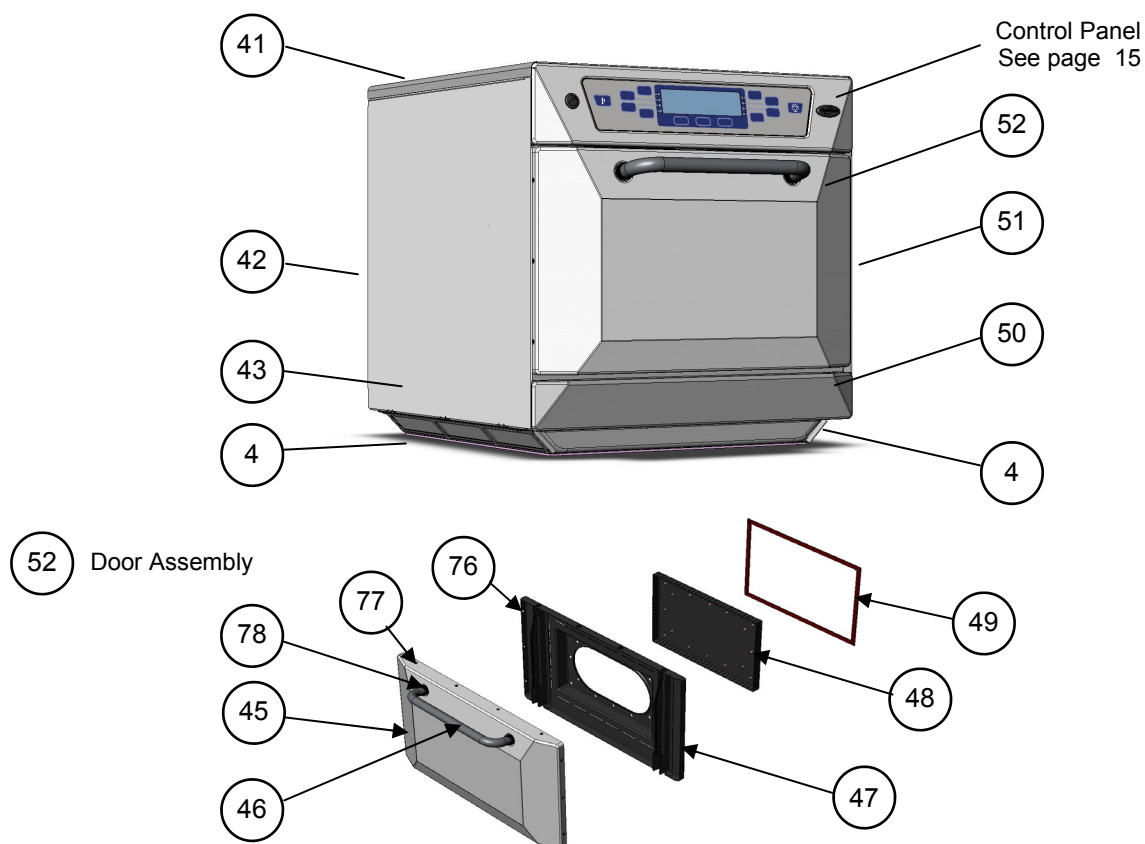

No.	Description	Part No.
4	Air Filter	SA276
41*	Top Trim	DV0187
42*	Rear Panel	SA329
43*	Side Panel LH	DV0091
45	Door Skin	DV0501
46	Door Handle	32Z1066
47*	Door Inner	SA331
48*	Door Choke	DV0168
49	Door Seal	DV0305
50*	Bottom Trim	DV0037
51*	Side Panel RH	DV0092
52*	Door Assembly	SA111
76	Cage Nut (Door Choke Plate)	105005
77	Screw M3 CsunK (Doorskin)	31Z3094
78	Door Handle spacer	DV0309

***Note:**

On Ovens with Serial No.s before 000745 (WAWA Models)

External Panels Items 41,42, 43, 45, 47,48, 50, 51, 52 are only available to special order.

PRINCIPAL COMPONENTS

Electronic Control Panel Assembly

Version 2.0/2.5 & WAWA

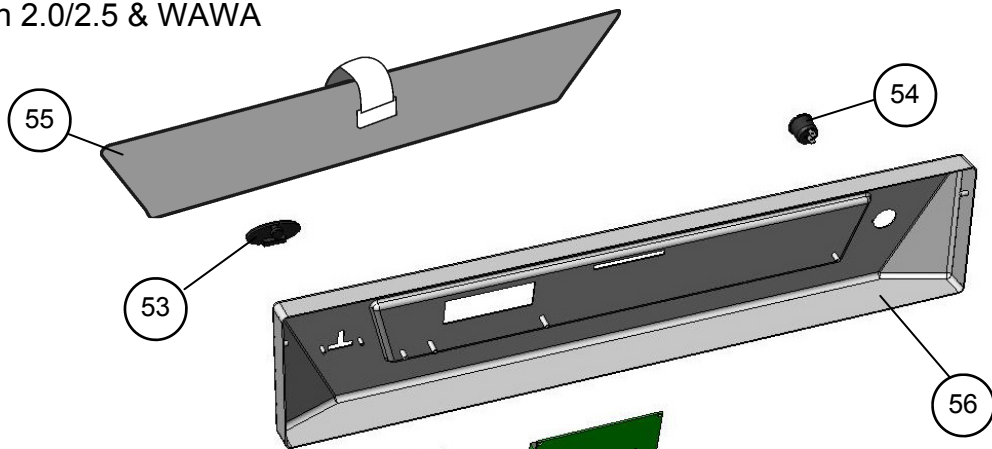

Version 3.0

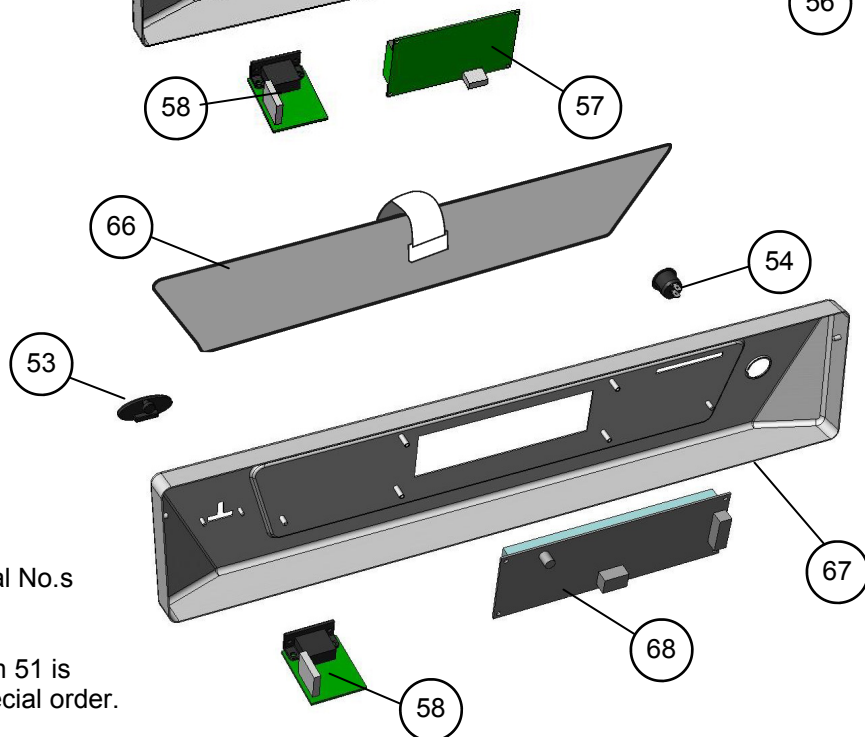

*Note:
On Ovens with Serial No.s
before 000745
(WAWA Models)
External Panels Item 51 is
only available to special order.

No.	Description	Part No.
53	MenuKey Dust Cover	DV0052
54	Power switch (On/Off)	30Z1318
55	GM Membrane Version 2.0 & 2.5	DV0055
	Membrane WAWA version	DV0192
56*	Front Panel Version 2.0	DV0036
57	Display Assembly & Header Version 2.0	30Z1299
58	MenuKey Socket	11K0005
66	GM Membrane Version 3.0	DV0254
67	Front Panel Version 3.0	DV0249
68	Display Assembly & Header Version 3.0	30Z1324

Part number identification chart 1

Ref. No.	Description	Part No.
1	Cavity High limit Stat	30Z1024
2	Motor Start Capacitor 2 μ F (Blue)	30Z1298
3	Filter 16A	30Z1340
4	Air filter	SA276
5	Stirrer motor Assembly	SA288
5A	Stirrer (inside cavity)	SA291
5B	Stirrer Gear	DV0552
6	Microswitch SW1, SW2, SW3, SW4	30Z1294
6A	Microswitch Assembly	SA212
7	Door Hinge Assembly RH	SA202
8	Magnetron Cooling Fan	30Z1295
9	Door Hinge Assembly LH	SA203
10	Motor Controller	30Z1293
11	Fuse 10A HRC	30Z0217
12	Gold resistor (220R)	30Z0235
13	Relay PCB Assembly	11K0004
14	Ribbon Cable 15way	11Z0298
15	Ribbon Cable 10way MenuKey	11M0117
16	Logic PCB Assembly Version 2.0	SA231
16	Logic PCB Assembly Version 3.0	SA260
17	Transformer LT (Low voltage)	30Z1155
18	Fuse 1A	30Z0957
19	Cable Gland	31Z0500
	Cable Gland Nut	31Z0499
20	Heater Element 208V 650W	DV0576
	Heater Element 220V 650W	DV0606
	Heater Element 240V 650W	DV0607
20A	Heater Element Collar	DV0058
21	Magnetron	30Z1349
22	Magnetron Thermistor Assembly	SA234
23	Convection (Hot Air) Motor Assembly	SA208
24	Thermistor Cavity	30Z1315
25	HV Capacitor 2500V 0.88 μ F (60Hz Models)	30Z1251
25A	HV Capacitor clip	31Z1261
27	Transformer 208/220/240V 60Hz	30Z1230
28	HT Rectifier	11H0010
29	Electrical Supply Lead Assembly	SA217
30	Terminal Block	31Z0447
31	Fuse 20A FLM	30Z1177
32	Fuse Holder 30A	30Z1178
34	Fuse Holder 10A	30Z0231
35*	Grease Filter (2 parts)	SA339
		SA340

Part number identification chart 2

Ref. No.	Description	Part No.
36	Stirrer Glass	DV0492
37	Rack Support	DV0114
38	Upper Impinger plate	SA211
39	Rack	DV0275
40	Lower Impinger plate	SA266
41*	Top Trim	DV0187
42*	Rear Panel	SA329
43*	Side Panel LH	DV0091
45*	Door Skin	DV0501
46	Door Handle	32Z1066
47*	Door Inner	SA331
48*	Door Choke	DV0168
49	Door Seal	DV0305
50*	Bottom Trim	DV0037
51*	Side Panel RH	DV0092
52*	Door Assembly	SA111
53	MenuKey Dust Cover	DV0052
54	Power switch (On/Off)	30Z1318
55	Membrane WAWA version	DV0192
55	Membrane GM Version Version 2.0	DV0055
56	Front Panel Version Version 2.0	DV0036
57	Display Assembly & Header Version 2.0	30Z1299
58	MenuKey Socket	11K0005
59	Sounder	SA257
60	Cool-down pan	32Z4028
61	Oven tray	MC3175
62	Handle	SA267
63	Griddle	DV0221
64	Griddle carrier	SA350
65	Chicken Griddle (SA350+DV0221+ DV0267)	SA133
66	GM Membrane Version 3.0	DV0254
67	Front Panel Version 3.0	DV0249
68	Display Assembly & Header Version 3.0	30Z1324
70	Fibre Optic Diode Board	11M0364
71	Solid State Relay	30Z1362
72	Fibre Optic Logic PCB	11K0013
73	Magnetron Cooling Duct LH	DV0039
74	Magnetron Cooling Duct RH	DV0040
75	Relay PCB Fuse	30Z0470
76	Cage Nut (Door Choke Plate)	105005
77	Screw M3 CsunK (Doorskin)	31Z3094
78	Door Handle spacer	DV0309
—	Stirrer cover sealant (tube)	31Z0527
—	Grease Filter Cartridge	SA340
—	Microswitch interlock spring	31Z1247

*Note:
 On Ovens with
 Serial No.s before 000745
 (WAWA Models)
 Grease Filter 35, Rack 39
 External Panel Parts
 41,42, 43, 45, 47, 48,
 50, 51, 52
 are only available
 to special order.

PROCEDURE FOR MICROWAVE EMISSION TEST (1)

Warning

Check for radiation emission after servicing. Should the emission be more than 4mW/cm² Inform Merrychef service centre immediately. After repairing or replacing any radiation safety device, keep a written record for future reference, as required by D.H.H.S. and Health and Welfare Canada regulation.

This requirement must be strictly observed. In addition, the emission reading must be recorded on the service repair documentation while in the customer's premises.

Please Note

DO NOT attempt to carry out the following procedure unless you have the following tools.

Tools required for microwave leakage test

1.0 Pint (600ml) glass beaker
Supply of cold water
Microwave leakage meter

Changing the Oven Profile

In order to carry out the test the oven **PREHEAT** must be set to **OFF**[V3.0] or **0°F**[V2.0] to switch off the convection heaters and the **Manual** controls must be set to **ON** [V3.0] or **PROGRAM/MANUAL**[V2.0].

When the test is completed the oven must be returned to its original settings or the appropriate MenuKey can be used to reset the oven automatically.

See Appendix 6 for changing the Oven Profile

Read and understand all of these notes and procedure before carrying out this operation.

Note before measuring.

- Make sure that the survey meter you are using has been calibrated and is suitable for measuring frequencies of 2,450 MHz.
- Do not exceed meter full scale deflection, leakage meter should initially be set to the highest scale, then adjusted down as necessary to ensure that low readings are measured on the most sensitive range.
- To prevent false readings, hold the probe on the grip provided and move along the areas indicated on the following page.
The probe should be moved at 1 inch/second (2.5cm/second)).
- With any casework removed the leakage should not exceed 4mW/cm².
- When measuring the leakage, always hold the probe at 2inches (50mm) from the test area using the probe supplied with the instrument.
- Always hold the probe at right angles to the oven and point of measurement

Procedure:

1. Place 0.5 pint (275ml) of cold water in the 1.0 Pint (600ml) glass beaker.
2. Place the 1.0 Pint (600ml) glass beaker in the centre of oven.
3. Set the leakage meter to the appropriate scale/range.
4. Set a time of 30 seconds with Fan speed at 10% and Power at 100%.
5. Press Start and move the survey meter probe along the areas indicated on page 21. Open the door at 30 seconds and taking care change the water. If the water boils the meter readings will be inaccurate.

Manual Mode

If the manual mode screen does not appear it must be changed in the OVEN PROFILE see Appendix 6

On completing the test remember to return the Oven Profile and PREHEAT temperature to the original settings.

PROCEDURE FOR MICROWAVE EMISSION TEST (2)

- Readings must be **below** 4mW/cm². If a level greater than 4mW/cm² is observed, this should be reported to Merrychef Service Division immediately.
- In any case, notes should be kept of the leakage that is observed. In terms of level and position on the oven. This should be kept with the service documentation.

Test for microwave leakage at all points marked with a 

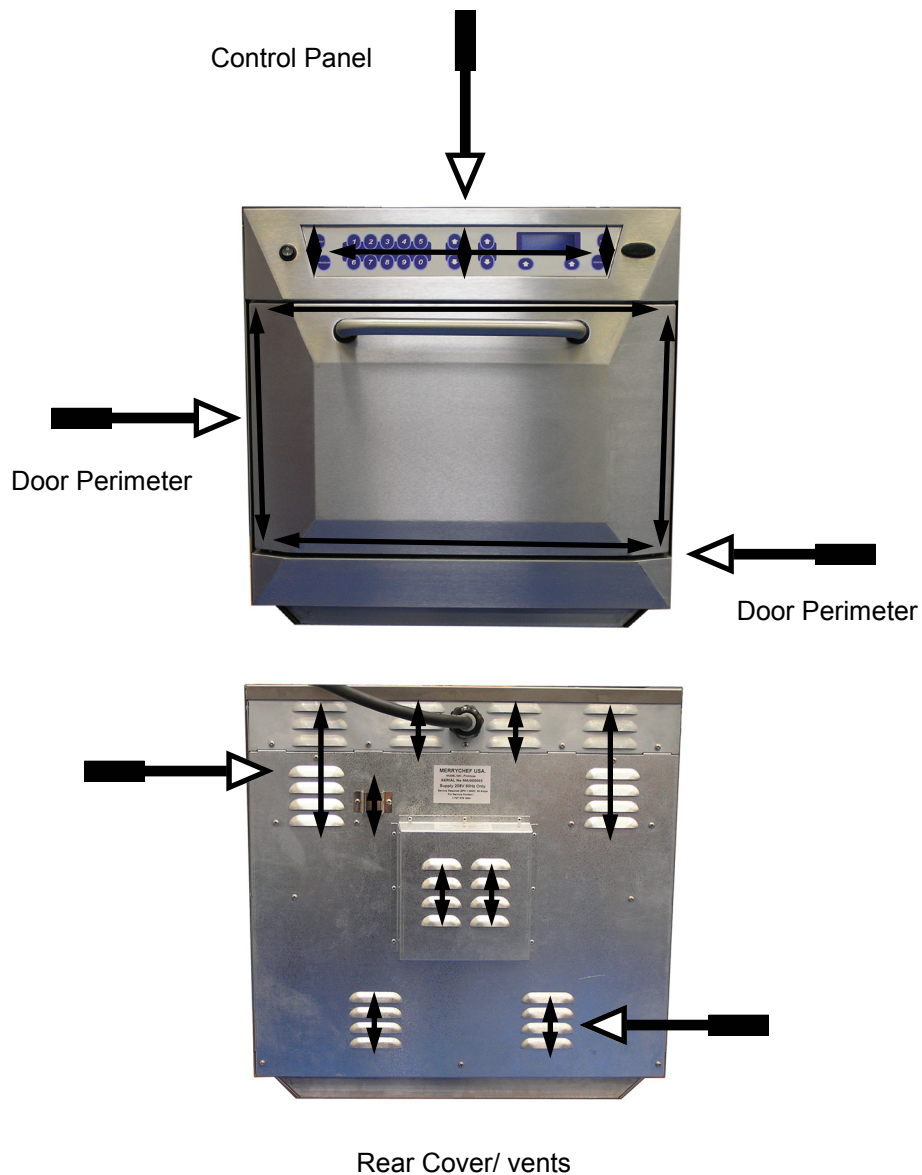

PROCEDURE FOR POWER OUTPUT MEASUREMENT

The power output specification 1500W on this model is established under IEC 705 standard method. This method is only workable in Laboratory controlled conditions.

An approximate method is as follows:

Ensure the oven is cold before commencing the test

Changing the Oven Profile

In order to carry out the test the oven **PREHEAT** must be set to **OFF**[V3.0] or **0°F**[V2.0] to switch off the convection heaters and the **Manual** controls must be set to **ON** [V3.0] or **PROGRAM/MANUAL**[V2.0]

When the test is completed the oven must be returned to its original settings or the appropriate MenuKey can be used to reset the oven automatically.

See Appendix 6 for changing the Oven Profile

Test procedure:

1. Fill one beaker (glass or plastic) with 2.11 pints (one litre) of tap water at about 68°F (20°C) and measure the water temperature.
(Use a thermometer with a $\frac{1}{10}$, 0.1 degree gauge).
2. Place the beaker in the centre of the cold cavity.
3. Version 2.0 Press the Manual Function Pad to enter **Manual Mode**
Version 3.0 Press the lower RH function pad below the display to enter **Manual Mode**
Set **Time** to 1 minute 3 seconds, Power to 100% and Fan to 0%.
Press the **Start** pad and wait until the counter reaches zero.
4. Take the beaker out immediately stir the water with a plastic implement and measure the water temperature.

Manual Mode

If the manual mode screen does not appear it must be changed in the OVEN PROFILE see Appendix 6

Calculate the temperature rise of water in the beaker.

The temperature rise of the water should be within the following range:

Temperature Rise

27°F (15°C) Minimum

36°F (20°C) Maximum

Note:

Power Output is affected by the line voltage under load.

For correct Power Output measurement the line voltage under load must be correct.

PROCEDURES FOR PRINCIPAL COMPONENTS TEST (1)

1. Power Transformer Test

You will need:

- A Digital Multi-meter (D.M.M.)
- A Megger or similar resistance meter using 500V d.c.

WARNING: High voltages and large currents are present at the High Voltage Capacitor. It is very dangerous to work near this part when the oven is on. **NEVER** make any voltage measurements at the High Voltage circuits, including the magnetron filament.

WARNING: Even when the oven is not cooking, the High Voltage Capacitor has High Voltages present because of the Soft Start circuit. Isolate the oven before testing.

See Safety Code (Page 4)

- 1 Isolate the oven from the mains supply.
- 2 Ensure that the High Voltage Capacitor is discharged before commencing work.
- 3 Remove all connections from the Power Transformer.
- 4 Using a D.M.M., check the resistance of the windings. Results should be as follows:

a	Mains winding between tags	Approx. 1.1 Ω
b	High Voltage winding	Approx. 60 Ω
c	Filament winding between terminals	Less than 1 Ω

- 5 Using a Megger, test the insulation resistance between:

Primary winding and chassis	Pass if over 10 M Ω
Filament winding and chassis	Pass if over 10 M Ω

One end of the High Voltage winding is connected to the chassis, so this is not tested.

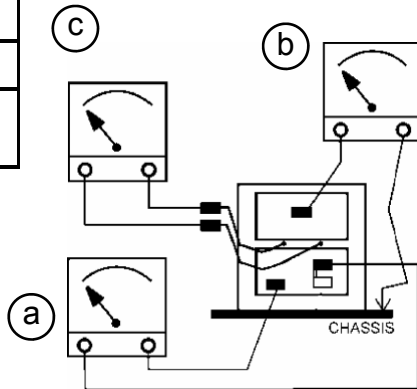

2. High Voltage Capacitor Test

You will need:

- A Digital Multi-meter (D.M.M.)
- A Megger or similar resistance meter using 500V d.c.

WARNING: High voltages and large currents are present at the High Voltage Capacitor. It is very dangerous to work near this part when the oven is on. **NEVER** make any voltage measurements at the High Voltage circuits, including the magnetron filament.

WARNING: Even when the oven is not cooking, the High Voltage Capacitor has High Voltages present because of the Soft Start circuit. Isolate the oven before testing.

See Safety Code (Page 4)

1. Isolate the oven from the mains supply.
2. Ensure that the High Voltage Capacitor is discharged before commencing work.
3. Remove all connections from the High Voltage Capacitor.
4. Using a D.M.M., check for continuity between the terminals & compare results with table on next page.

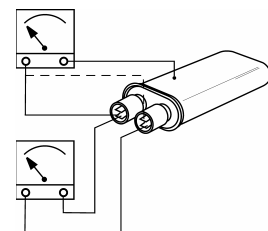

PROCEDURES FOR PRINCIPAL COMPONENTS TEST (2)

(High Voltage Capacitor Test continued, ensure steps 1-4 on previous page have been completed)

Between Terminals	Pass if approximately 10 MΩ
Between Terminals and Case	Pass if open circuit

5. Using a Megger, test the insulation resistance between the terminals and the case.

Between Terminals and Case	Pass if over 100 MΩ
----------------------------	---------------------

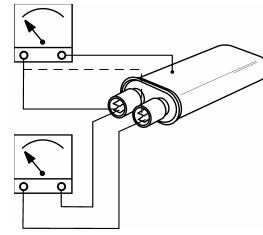

3. High Voltage Rectifier Test

You will need:

A Megger or similar resistance meter using 500V d.c.

WARNING: High voltages and large currents are present at the High Voltage Capacitor. It is very dangerous to work near this part when the oven is on. **NEVER** make any voltage measurements at the High Voltage circuits, including the magnetron filament.

WARNING: Even when the oven is not cooking, the High Voltage Capacitor has High Voltages present because of the Soft Start circuit. Isolate the oven before testing.

See Safety Code (Page 4)

1. Isolate the oven from the mains supply.
2. Ensure that the High Voltage Capacitor is discharged before commencing work.
3. Remove all connections from the High Voltage Rectifier.
4. Using the Megger, test for continuity in both directions. Compare results with the table.

Open Circuit both ways	FAIL
Conducts one way only	PASS
Short Circuit both ways	FAIL
Conducts one way, leaks the other	FAIL

4. Magnetron Test

You will need:

A Megger or similar resistance meter using 500V d.c.

A Magnetron can be tested for an open filament or a short circuit by carrying out a continuity check.

WARNING: High voltages and large currents are present at the High Voltage Capacitor. It is very dangerous to work near this part when the oven is on. **NEVER** make any voltage measurements at the High Voltage circuits, including the magnetron filament.

WARNING: Even when the oven is not cooking, the High Voltage Capacitor has High Voltages present because of the Soft Start circuit. Isolate the oven before testing.

See Safety Code (Page 4)

1. Isolate the oven from the mains supply.
2. Ensure that the High Voltage Capacitor is discharged before commencing work.
3. Remove all connections from the Magnetron.
4. A continuity check across the Filament terminals should be 1ohm or less
5. A continuity check between each filament terminal and the metal outer should read open.

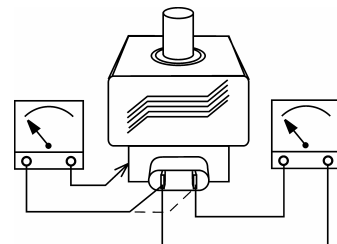

PROCEDURE FOR DOOR INTERLOCK ADJUSTMENT AND TEST 1

The door on the 402s oven is monitored by four microswitches. Three are used in the conventional "Primary, Secondary and Monitor" switch arrangement shown below and the fourth sends a signal to the Logic PCB. The switches operate as follows:

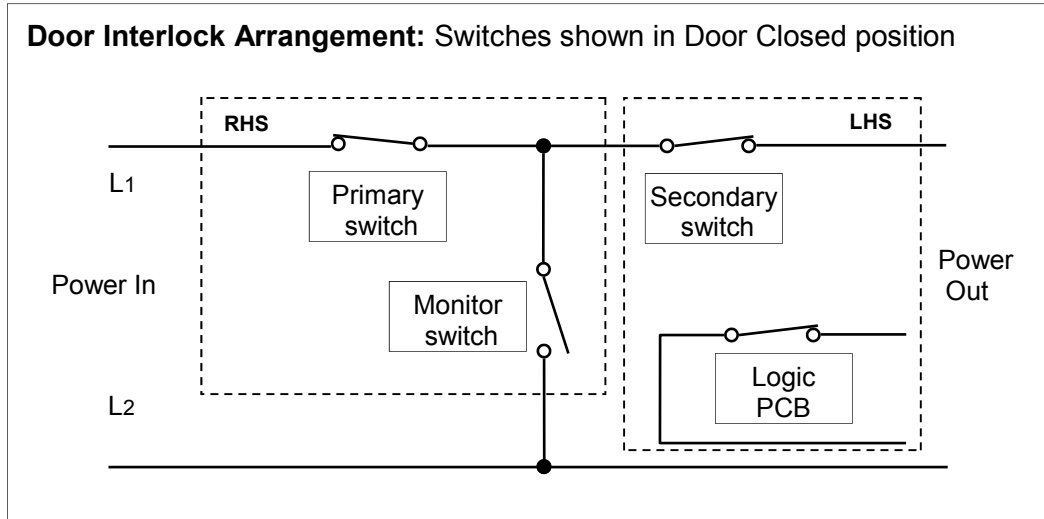

1. Monitor switch

The Monitor switch will produce a short circuit across the mains supply when the door is opened if the Primary interlock switch is faulty, thus blowing the microwave fuse and rendering the oven inoperative.

2. Primary Interlock and Secondary Interlock

The Primary switch will cut off the microwave emissions from the oven when the door is opened by breaking the electrical supply circuit to the transformers. The Secondary interlock switch will cut off the microwave emission if the Primary switch has failed.

Note:

If operation of the Monitor switch has caused the Microwave Fuse to blow, the Primary and Monitor microswitches must be changed as they may have been damaged by the high short-circuit currents involved.

Right Side

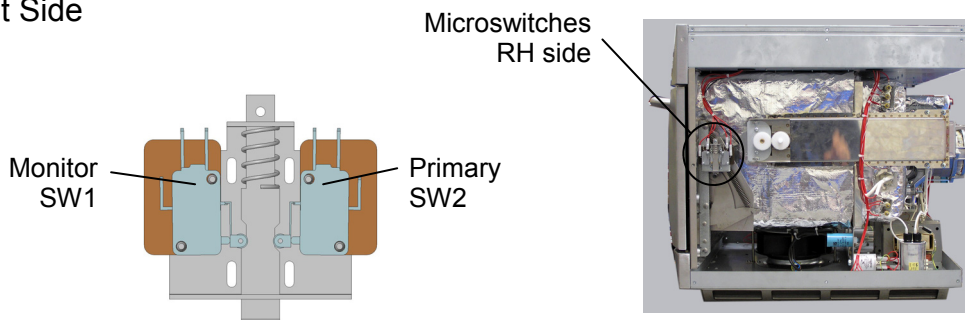

Left Side

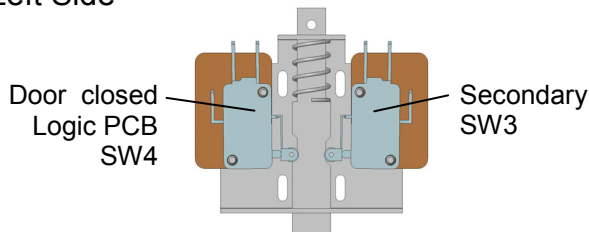

PROCEDURE FOR DOOR INTERLOCK ADJUSTMENT AND TEST 2

It is vital that the microswitches are adjusted to the correct position. There are two sets of switch assemblies located either side of the oven.

The interlocks ensure that the oven will not operate microwave with the door open.

WARNING

Before adjusting the microswitch assemblies ensure that the oven has been isolated from the electrical supply.

Please note the terminals on the microswitches remain live when the oven is switched off, so complete isolation is essential.

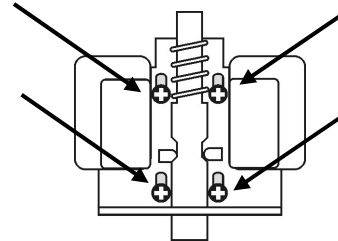

Objective

With a 1mm spacer located as shown, both switches on both sides should be activated/ closed position.

With a 5mm spacer located as shown SW2 and SW3 should be open.

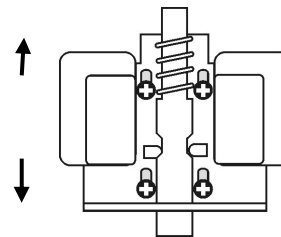

Method of adjustment.

By loosening the four screws on each mounting bracket the microswitch assembly can be raised or lowered and thereby the switches can be made to operate at different door positions.

Procedure.

1. **Isolate the oven from the Electrical supply.**
2. Place a 1mm spacer between the cavity face and the door seal as shown.
3. Working on the right hand side, adjust the bracket so the SW2 'just' operates.
4. Working on the left hand side, adjust the bracket so that SW3 'just' operates.
5. Remove the 1mm spacer and then place a 5mm spacer in the same position. Check that SW2 and SW3 are open circuit and not operated.
6. Repeat the steps above to ensure the setup is correct.
7. Ensure that all the screws are tightened.
8. Reconnect the electrical supply.

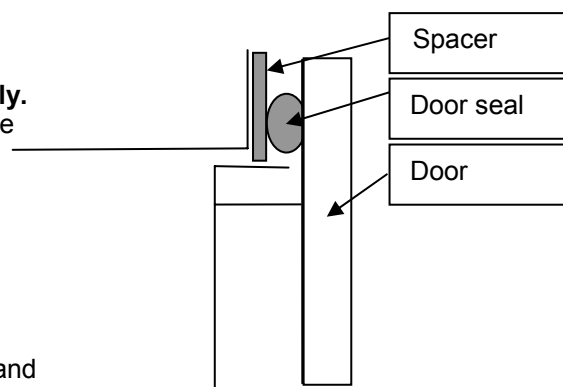

PRINCIPAL COMPONENTS: Hot Air Motor & Controller 1

Convection and Fan Speed Control

The convection heat is provided by 5 elements located in the hot box at the rear of the oven cavity. The hot air from the hot box passes over catalytic converters and is circulated into the bottom and top of the cavity through the impinger plates. It returns through the removable grease filter at the back of the cavity and into the fan.

Convection motor

The convection motor is a 3-phase AC motor having a maximum speed of 7200 rpm controlled by a motor speed controller.

The windings are thermally protected and in the event of a thermal fault a trip will operate and shut down the motor speed controller.

Step	Motor/ controller fault finding
1	208V/240V, 60Hz Electrical supply into motor controller
2	Three phase connections to motor
3	Speed Controller connections to logic board
4	Motor thermal cut-out (short circuit)
5	Motor rotates freely/ not seized
6	Motor winding resistances: Blue-Black 3 Ohms—4 Ohms Black-Brown 3 Ohms—4 Ohms Brown-Blue 3 Ohms—4 Ohms Black or Brown or Blue to Earth (Open circuit)

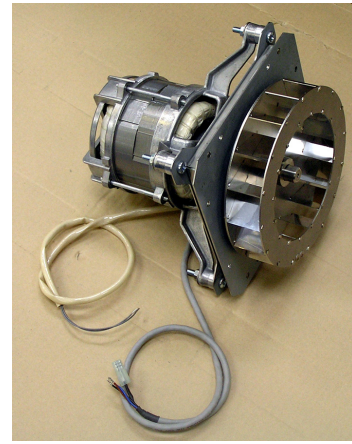

No.	Description	Part No.
20	Heater Element 208V 650W 68Ω	DV0328
20	Heater Element 240V 650W 88Ω	DV0337
20A	Heater Element Collar	DV0058
23	Convection (Hot Air) Motor Assembly	SA208
	Gasket Set	SA332

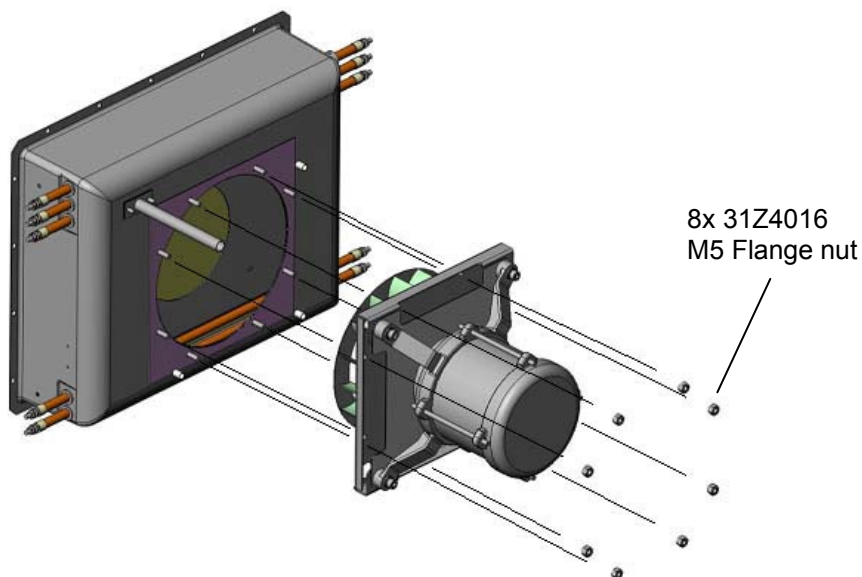

PRINCIPAL COMPONENTS: Hot Air Motor & Controller 2

Motor Controller

Provides an AC, 3-phase switched mode drive to the convection motor and is controlled by a 0 - 10 Volt signal from the logic board. This allows the motor to be adjusted from approximately 1500 rpm to 7000 rpm in steps of 5%.

- Door Open = 1500 RPM
- Door Closed (not cooking) = 3500 RPM
- Door Closed (cooking) = as specified by program or setting

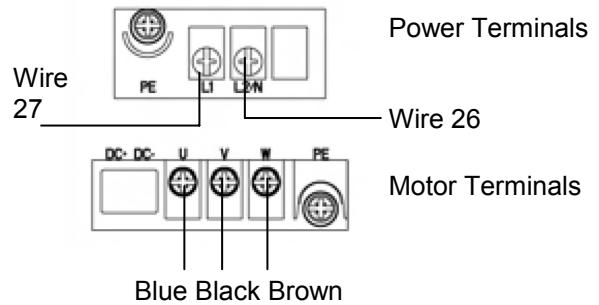
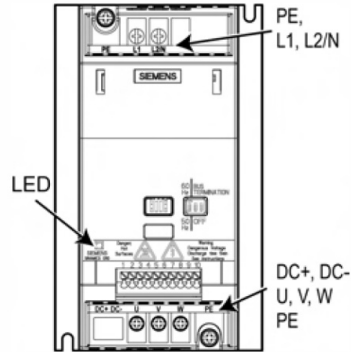

Motor Speed and Logic board voltage table

Fan speed %	Voltage dc	RPM	Condition
100%	10V	7000	Full Speed
50%	5V	3000	Door Closed
20%	2V	1500	Door Open



Grey wire to Motor

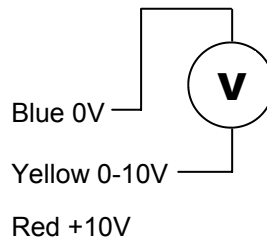

Displays and messages: LED status display

LED	Meaning	Position
LED Off	Inverter Off / No supply	
Long On & Off (1sec)	Power On / Ready	
LED On steadily	Inverter Running	
Long On (0.5 sec)/ short Off	General Warning	
Very Short On & Off (0.1sec)	Fault Condition	

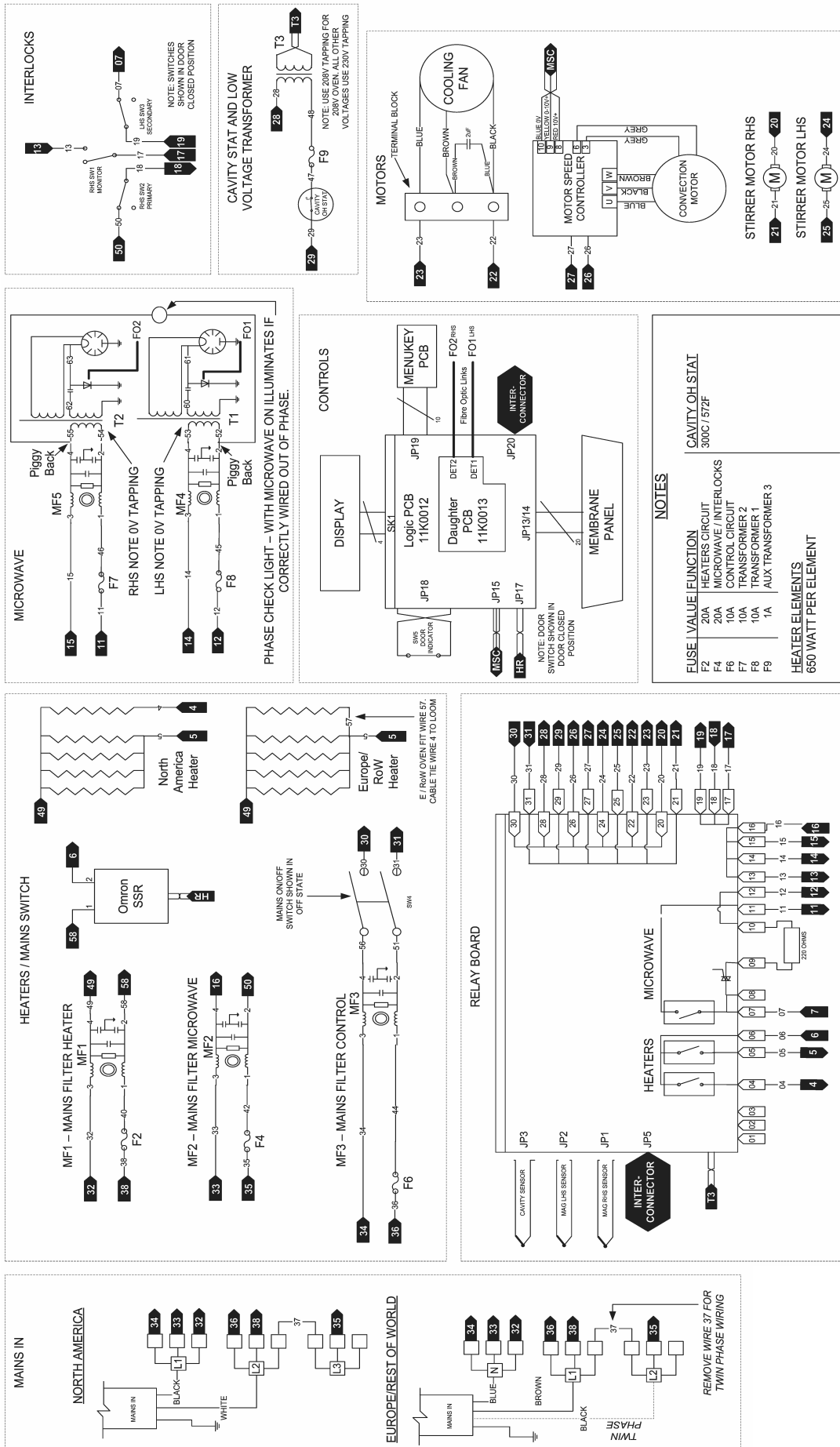

CIRCUIT DIAGRAM: Issue 16

Trouble-Shooting Guide

Is the problem Food Quality or Fundamental Operational Issue?

Food Quality



Standard Food Quality Checks

- Check that the PREHEAT temperature is set correctly.
See User Manual.
- Check that the food being cooked has been stored at the correct temperature.
- Check that the correct program is being used.

Still Have a problem:
Select a Category.

- **Cold Food Page 32**
- **Core TemperaturesLow Page 32**

Fundamental



Standard Electrical Checks

- Check that oven is connected to an Electrical Power supply and that any trip that supplies the unit is not switched off.
- Check that the oven is switched on.
- Check the Electrical Power supply voltage at the input terminal block.
- Check that all fuses are intact.
- Check that the overheat stat has not tripped this can be checked by measuring the voltage across the Auxiliary transformer.

Still Have a problem:
Select a Category.

- **No Display Page 31**
- **Cavity Sensor Error Page 33**
- **Magnetron / Over heat errors Page 34**

Note : The following Diagnosis procedures may not expose all possible errors but have been included for general guidance.

No Display

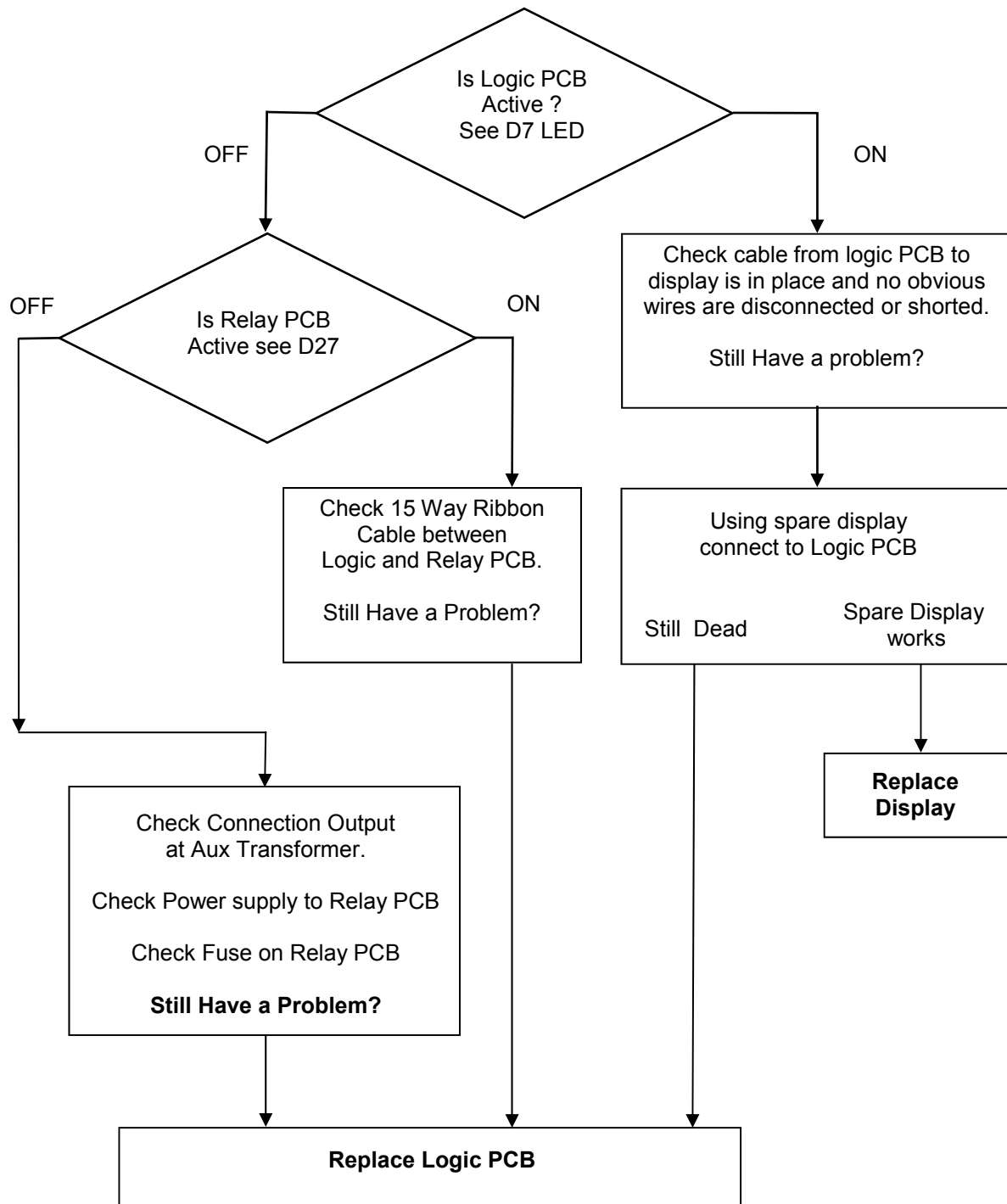

Cold Food

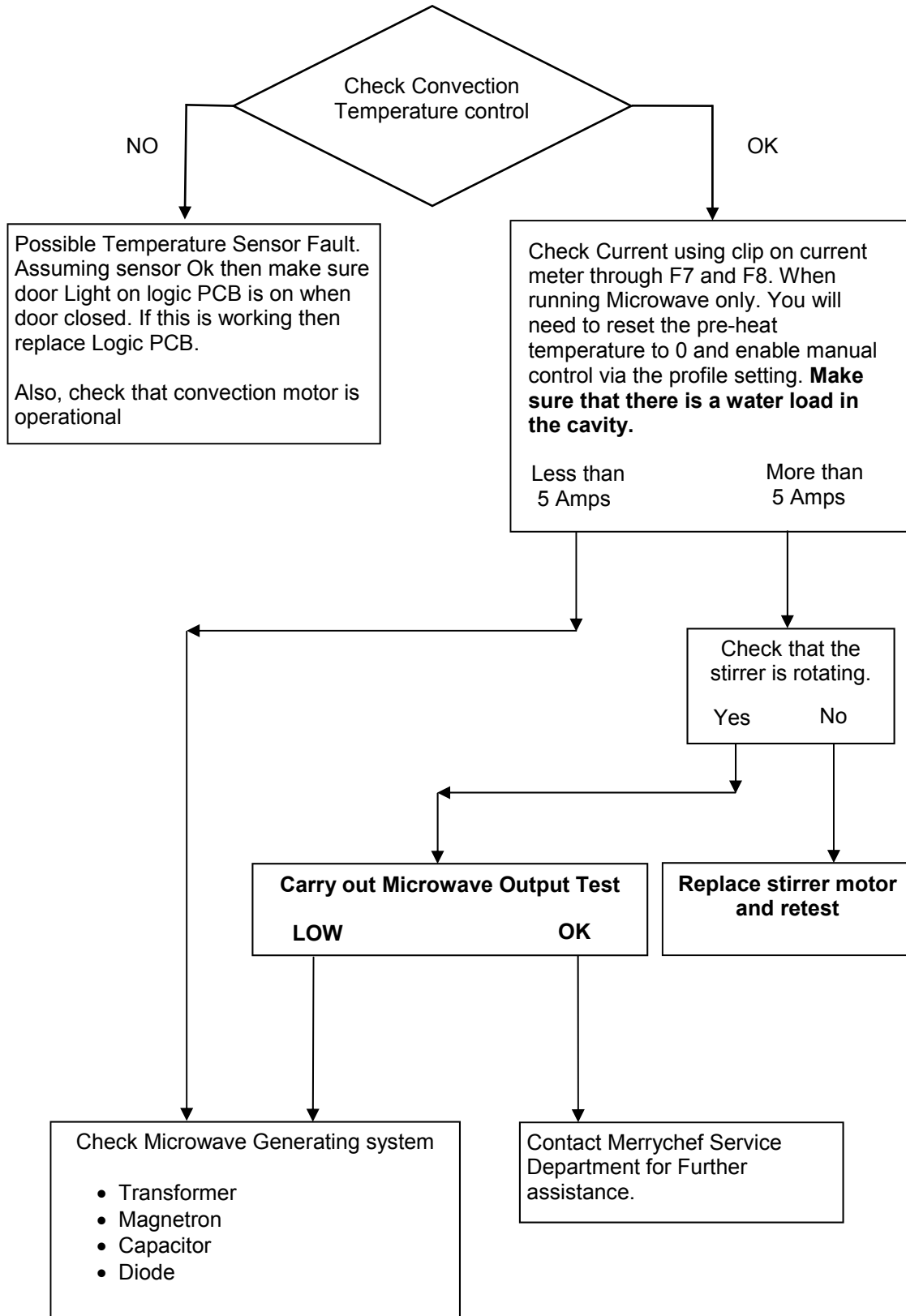

Cavity Sensor Error

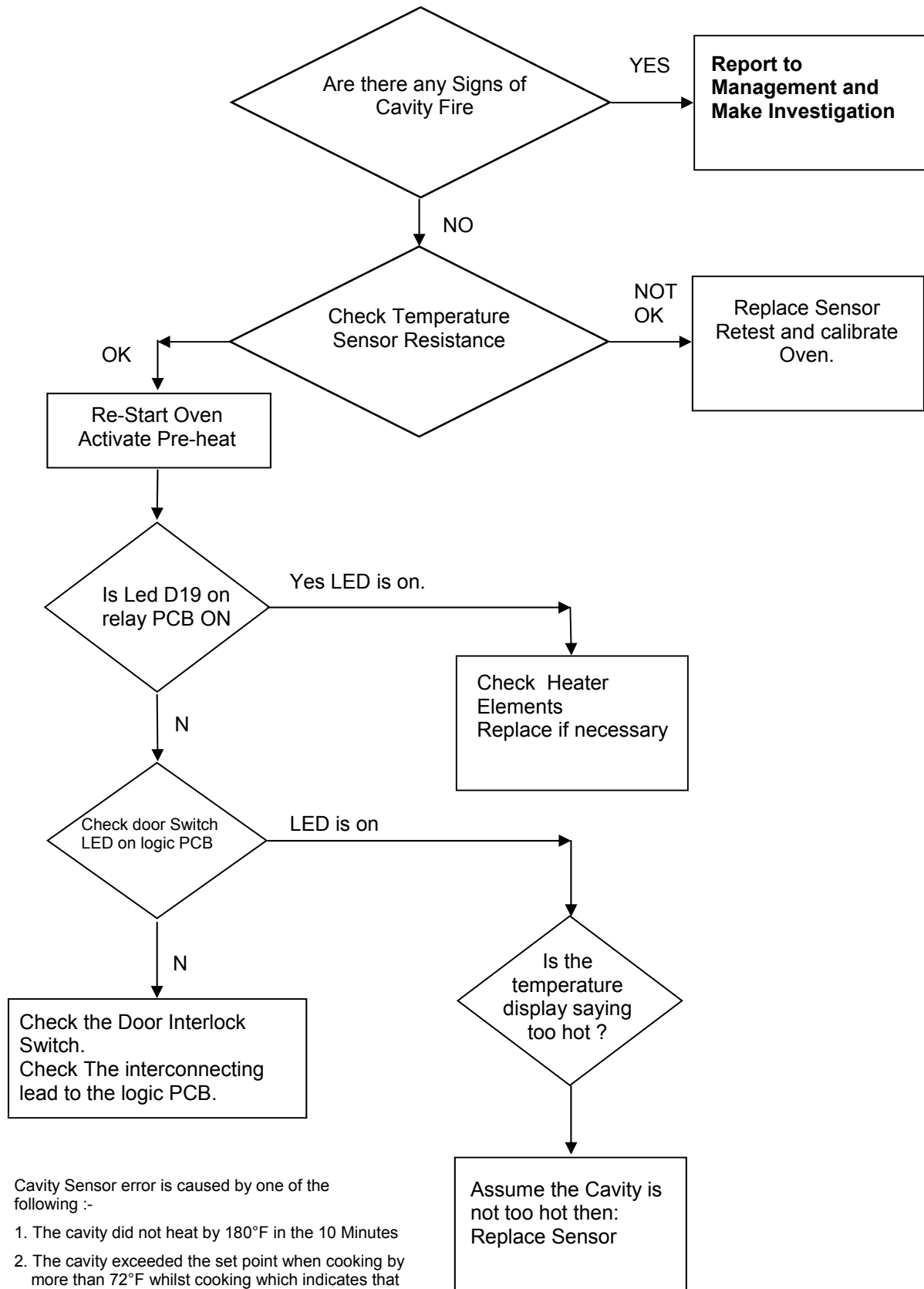

Magnetron / Overheat issues

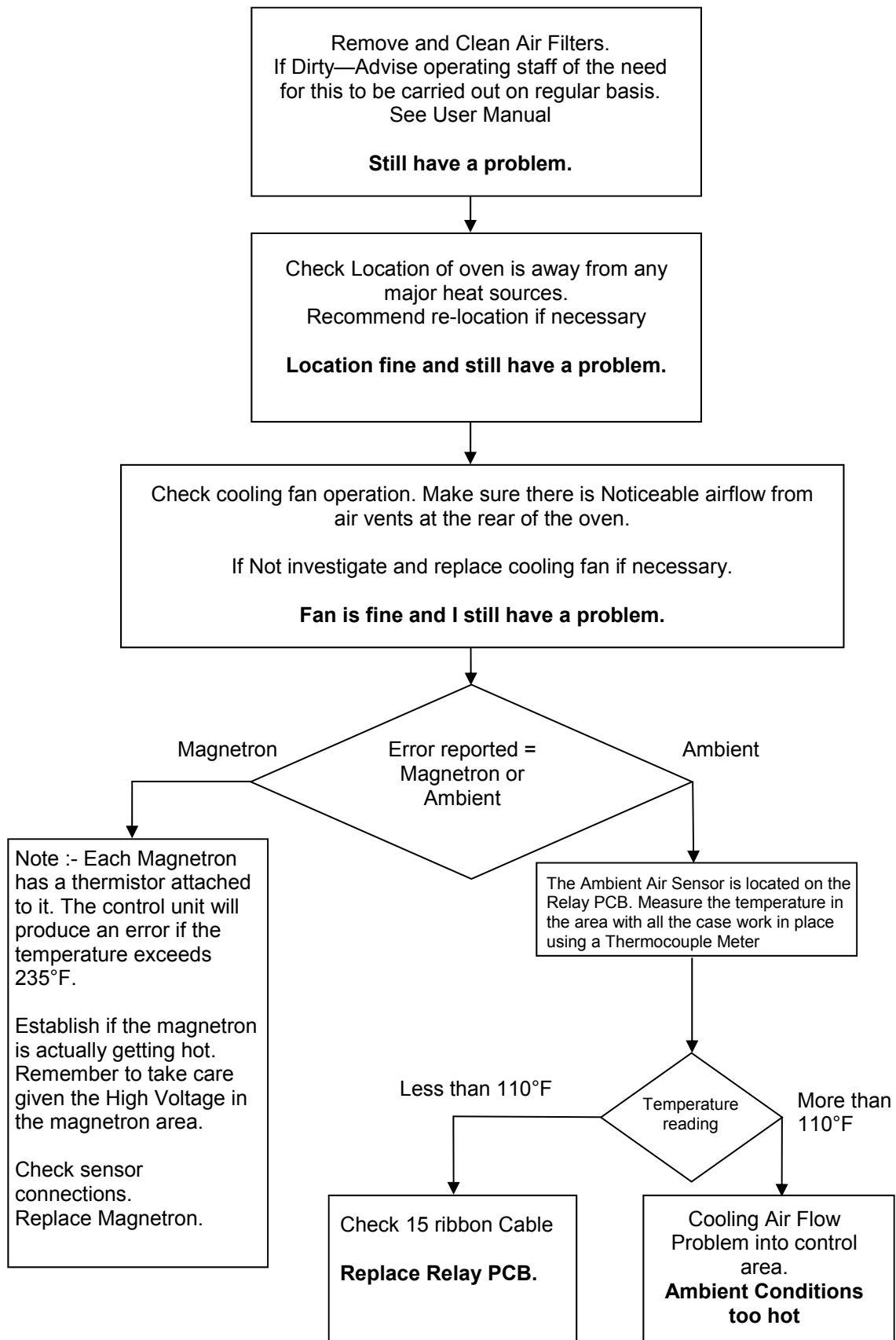

APPENDIX 1: TEMPERATURE SENSOR RESISTANCE DATA

Temperature Sensor Resistance

Temp °F	Temp °C	Min. Rate kΩ	Standard Rate kΩ	Max. Rate kΩ
212	100	11.490	13.060	14.810
302	150	2.803	3.161	3.434
392	200	0.950	1.000	1.050
482	250	0.3572	0.3865	0.4171

$$R(200)^{\circ}\text{C} = 1 \text{ k}\Omega \pm 5\%$$

Note:

These resistances will only be apparent in a stable cavity temperature as the sensor has a slow response time.

APPENDIX 2: MenuKey Version 2.0 models

The MenuKey System automatically changes all the cooking programs on the oven from a pre-programmed electronic key.

To change the menus on the oven:

- 1 Ensure the power switch is **OFF**.
- 2 Lift the **MenuKey** cover in the top front panel of the oven and put the key in the slot.

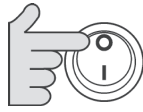

Do not remove the key during download sequence as this could corrupt the data on the key

MENUKEY2



- 3 With the key still in place switch the power switch **ON**. The oven will now go through the program download sequence by displaying the following:



The MenuKey Code. e.g. 555

The MenuKey CS e.g. 0A06

MenuKey CS (checksum) confirms the menus on this key are valid for the MenuKey Code.

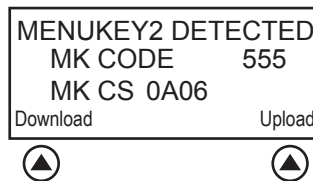

- 4 Confirm that the MenuKey Code and MenuKey CS are correct and press **Download** Function key to load the programs into the Oven memory.

Download

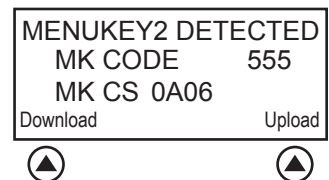

Note: Downloading from a MenuKey will clear all the existing programs

Continue

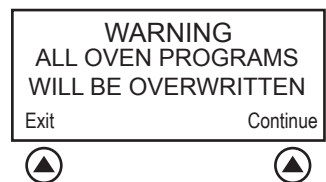

Check that the key is correct then press the **Continue** function key to proceed with the Download

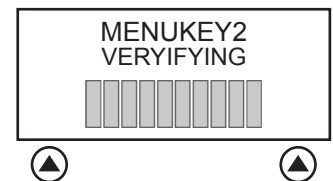
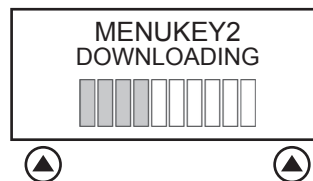

On completion of the download press the **Exit** function key to return the oven to standby mode. The display briefly will show the following:

Exit

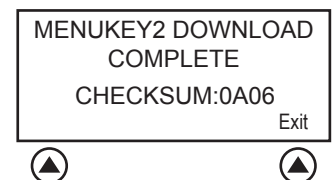

Oven Model No. Software & MenuKey serial No.

The standby screen will then display

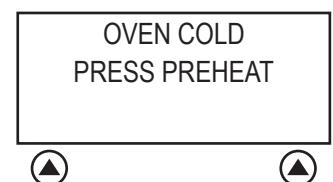
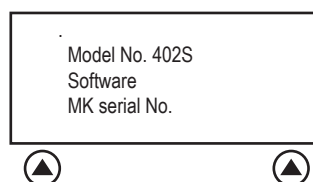

Remove the MenuKey and keep in a safe place.

APPENDIX 2: MenuKey Version 3.0 models

The MenuKey System automatically changes all the cooking programs on the oven from a pre-programmed electronic key.

To change the menus on the oven:

WARNING

Downloading from a MenuKey will clear all the existing programs

Do not remove the key during download sequence as this could corrupt the data on the key

MENUKEY2

Check that the key has the correct number/code for the programs you want to load into the oven memory

- 1 Ensure the power switch is **OFF**.
- 2 Lift the **MenuKey** cover in the top front panel of the oven and put the key in the slot.
- 3 With the key still in place switch the power switch **ON**. The oven will now go through the program download sequence by displaying the following:

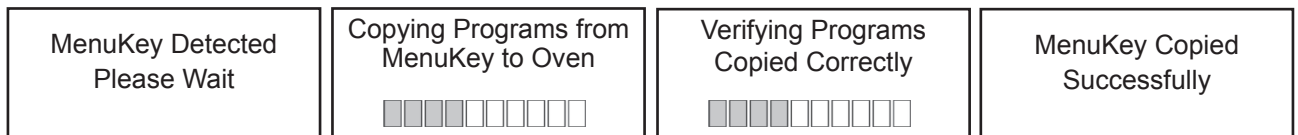
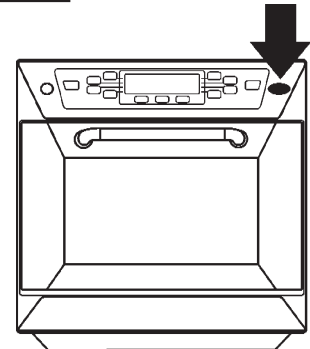
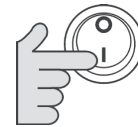
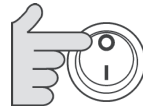

The display briefly will show the following : Oven Model No., Software & MenuKey serial No. The Oven will then commence heating up to the PREHEAT temperature ready to cook.

- 4 Remove the MenuKey and keep in a safe place.

Saving Programs to a MenuKey

In the **CATEGORIES** screen select **EDIT SCREEN** (Pad name hidden) then select **CREATE MENUKEY**

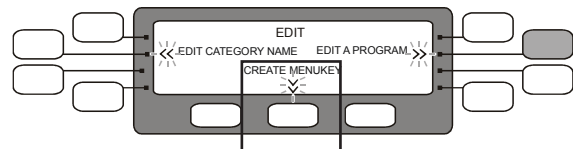
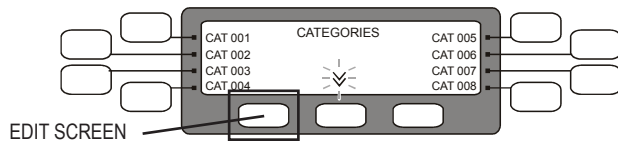

- 1 Enter a number for the MenuKey Code to identify the new MenuKey, use the +/- Function Pads.

For an explanation of the following features see Setting the Oven Profile Page 11

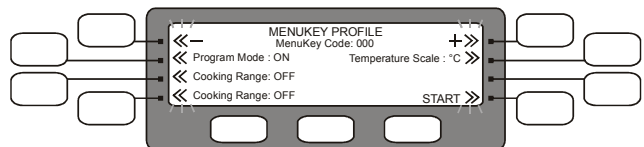

- 2 Set the Program Mode to **ON** or **OFF**,
- 3 Set Manual Mode to **ON** or **OFF**:
- 4 Enter the Lower Band temperature setting **15-75°C**
- 5 Set the oven Temperature Scale **°C**

Insert a MenuKey and press START to copy the programs. The display shows the following:



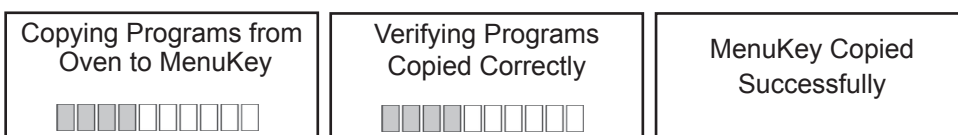

WARNING
Any programs already on the key will be deleted



The Display returns to the CATEGORIES screen and the Oven will heat up to the PREHEAT temperature ready to cook.

APPENDIX 3: Cool Down Procedure

To cool down and clean a hot oven

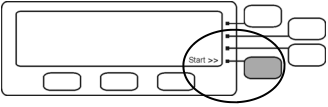
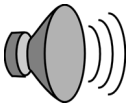
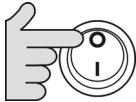
Action	EC402s V2.0	EC 402s V3.0
To commence Cool Down procedure Press		
Place Ice in cavity 	COOL DOWN MODE PLACE ICE IN CAVITY	COOL DOWN MODE PLACE LOAD IN CAVITY AND PRESS START
Press	Continue 	 Start
The oven cools down for approximately 30 minutes	COOL DOWN MODE OVEN HOT PLEASE WAIT (Also in Spanish)	COOL DOWN MODE OVEN HOT PLEASE WAIT
Cycle ends 	COOL DOWN COMPLETE READY FOR CLEANING	Turn oven off and ensure Air Filters are clean
Switch oven off ready for cleaning		

APPENDIX 3: CLEANING: 1

For the oven to operate at peak efficiency, the cavity, door and air filters and grease filter must be kept clean.

A daily cleaning routine will ensure that you comply with the required hygiene standards and will help to maintain and prolong the efficiency of your oven.

Follow the SAFETY INSTRUCTIONS at the beginning of this manual.



WARNING: DO NOT use caustic cleaners on any part of the oven or oven cavity as it will cause permanent damage to the Catalytic Convertors

- **ALWAYS switch off at the electrical supply before cleaning**
- **Complete COOL DOWN procedure and allow the oven and accessories to cool before commencing cleaning**
- **As required wipe out spillages with disposable paper wipes**
- **NEVER use steel wool, knives or harsh abrasives on any part of the oven**



As with all electrical appliances, it is wise to have the electrical connections inspected periodically.

Faults arising from neglect or misuse including use without clean filters in place are not covered by the guarantee. Service visits as a result of such faults will be chargeable.



DO NOT use the oven without clean air filters and cavity grease filter in place

START UP: OVEN COATING PROCEDURE (clean, cold oven)

1. With the oven clean and cold, spray Merrychef Oven Protector onto the sponge



2. Spread Oven Protector lightly onto all internal surfaces of the oven



3. Spread Oven Protector lightly onto the internal surface of the oven door



4. Switch the oven ON when the oven has reached operating temperature it will take 30 minutes to cure the Oven Protector.

Note: oven protector turns light brown when cured

APPENDIX 3: CLEANING: 2

- **ALWAYS** switch off at the electrical supply and allow oven to cool before cleaning
- **CAUTION:** Allow the oven and accessories to cool before commencing cleaning



WARNING: DO NOT use caustic cleaners on any part of the oven or oven cavity as it will cause permanent damage to the Catalytic Convertors

Equipment: Merrychef oven cleaner, Merrychef Oven Protector, heat proof gloves, protective rubber gloves, non-abrasive nylon scrub pad, cleaning towel and cloths, eye protection and dust mask (optional)

COLD OVEN: CLEANING INSTRUCTIONS (following cool down)

CAUTION: Wear protective rubber gloves when cleaning the oven

Oven Parts and filters & Oven Cavity

Wash all parts in warm soapy water. Wash off using a clean cloth and plenty of clean, warm water. Dry using a fresh, clean cloth.

Remove air filters both sides



Remove the rack and lift out bottom impinger plate

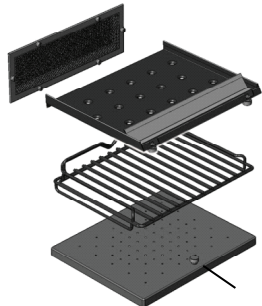

Remove top impinger plate

Undo fasteners

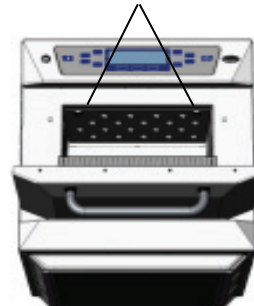

To remove grease filter push down and lift out

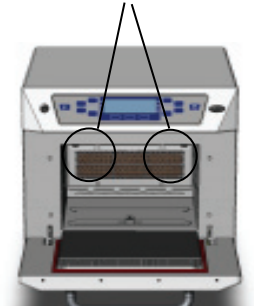

If the door seals are damaged, the oven must be repaired by an approved Servicer.

DO NOT spray directly into the fan opening at the rear of the oven

1.

Wear protective rubber gloves and protective glasses carefully spray Merrychef Oven Cleaner onto the internal surfaces of the oven except door seals. **DO NOT** spray directly into the fan opening at the rear of the oven



2.

For difficult areas leave to soak for 10 minutes. Leave the oven door open during cleaning. Use a non-abrasive nylon scrub pad/sponge to clean all internal surfaces and the inside of the door.



3.

Wash off using a clean cloth and plenty of clean warm water to rinse top, sides and back of oven. Dry using a fresh clean cloth or paper towel. Wipe the outside of the oven with a damp cloth.



4.

Replace clean oven parts

Grease Filter*
Top plate*
Bottom plate*
Air filters x2



DO NOT USE TOOLS

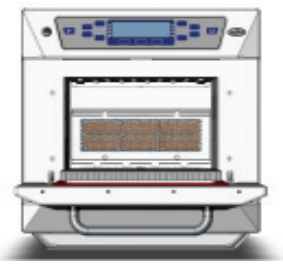

DO NOT use the oven without clean air filters and cavity grease filter in place



*When replacing impinger plates and the cavity grease filter use firm finger pressure to tighten fasteners **DO NOT USE TOOLS**

APPENDIX 4: Recommended spares lists USA

Part Number	Description	Qty	Unit	First Aid Kit	Service Kit	1-5 Ovens	5-50 Ovens	50-100 Ovens	Piece Qty for 600 Ovens
11H0010	HT DIODE ASSY	2	EA	2	2	2	6	12	72
11K0002	LOGIC BOARD MAIN ASSY (V2 & V2.5)	1	EA		1	1	3	6	36
11K0004	MAI RELAY PCB	1	EA		1	1	3	6	36
11K0005	MENU KEY SOCKET ASSY	1	EA			1	3	6	36
11K0012	402s LD LOGIC PCB ASSY (V3)	1	EA		1	1	3	6	36
11K0013	402s FIBRE OPTIC BOARD ASSY	1	EA		1	1	3	6	36
11M0117	DC VOLTAGE CONNECTOR 10 WAY	1	EA	1	1	1	3	6	36
11M0367	VCK HT DIODE ASSEMBLY	2	EA	2	2	2	6	12	72
11Z0298	15 WAY 0.1 RIBBON CABLE ASSY	1	EA	1	1	1	3	6	36
30Z0217	FUSE 1in 10A HRC	5	EA	5	5	5	15	30	180
30Z0231	FUSE HOLDER 1IN (13A)	3	EA	3	3	3	9	18	108
30Z0235	GOLD RESISTOR (220R)	1	EA		1	1	3	6	36
30Z0957	FUSE 1x1/4in 1A HBC (MAINS)	1	EA	1	1	1	3	6	36
30Z1024	OVERHEAT SAFETY STAT	1	EA		1	1	3	6	36
30Z1155	BLOCK TRANSFORMER B0012024	1	EA		1	1	3	6	36
30Z1177	20 AMP LITTELFUSE FLM020	4	EA	4	4	4	12	24	144
30Z1178	30A FUSE HOLDER	4	EA	2	4	4	12	24	144
30Z1230	60HZ TRANS MULTI 208 220 240	2	EA	1	2	2	6	12	72
30Z1251	0.88uF 2500V CAPACITOR	2	EA	1	2	2	6	12	72
30Z1293	MOTOR SPEED CONTROLLER - US	1	EA		1	1	3	6	36
30Z1294	MICROSWITCH WITH ROLLER	2	EA	2	2	2	6	12	72
30Z1295	MAGNETRON COOLING FAN	1	EA		1	1	3	6	36
30Z1298	CAPACITOR - MOTOR START - 2uF	1	EA		1	1	3	6	36
30Z1299	DISPLAY ASSY + HEADER V2 - V2.5	1	EA		1	1	3	6	36
30Z1315	THERMISTOR 150MM + LEAD 900MM	1	EA	1	1	1	3	6	36
30Z1318	2 POLE ROUND ROCKER SWITCH	1	EA	1	1	1	3	6	36
30Z1324	DISPLAY ASSY + HEADER V3	1	EA		1	1	3	6	36
30Z1340	FILTER 16A SCREW MOUNT	2	EA	2	2	2	6	12	72
30Z1349	MAGNETRON 2M248H-B	2	EA	2	2	2	6	12	72
30Z1375	CRYDON SOLID STATE RELAY	1	EA			2	6	12	72
31Z0186	DOOR SEAL SEALANT - 1 TUBE	1	TUBE	1	1	2	6	12	72
31Z0477	4 WAY MAINS TERMINAL BLOCK	1	EA			2	6	12	72
31Z0499	CABLE GLAND NUT	1	EA			2	6	12	72
31Z0500	CABLE GLAND LARGE	1	EA			2	6	12	72
31Z0527	STIRRER COVER - SEALANT 1 TUBE	1	TUBE	1	1	2	6	12	72
31Z1247	MICROSWITCH SPRING INTERLOCK	1	EA	1	1	1	3	6	36
32Z1066	DOOR HANDLE	1	EA			1	3	6	36
DV0037	BOTTOM TRIM	1	EA			1	1	2	12
DV0052	MENUKEY DUST COVER	1	EA			1	3	6	36
DV0055	MEMBRANE PANEL - V2 - 2.5	1	EA			1	3	6	36
DV0091	SIDE PANEL L/H	1	EA			1	1	2	12
DV0092	SIDE PANEL RH	1	EA			1	1	2	12
DV0094	TOP TRIM - V1	1	EA			1	1	2	12
DV0168	DOOR CHOKE (PRESSED)	1	EA			1	3	6	36
DV0187	TOP PANEL (PRESSED)	1	EA			1	3	6	36
DV0192	WAWA MEMBRANE	1	EA		1	1	3	6	36
DV0203	SEAL - CERAMIC COVER	2	EA	2	2	2	6	12	72
DV0254	402s MEMBRANE V3	1	EA		1	1	3	6	36
DV0275	RACK V3	1	EA			1	3	6	36
DV0305	DOOR SEAL 402S	1	EA	1	1	2	6	12	72

APPENDIX 4: Recommended spares lists USA CONT.

Part Number	Description	Qty	Unit	First Aid Kit	Service Kit	1-5 Ovens	5-50 Ovens	50-100 Ovens	Piece Qty for 600 Ovens
DV0328	HEATER ELT 208V 650W WATLOW	5	EA	5	5	5	15	30	180
DV0337	HEATER ELT 240V 650W WATLOW	5	EA	5	5	5	15	30	180
DV0492	STIRRER COVER - CERAMIC	2	EA	2	2	2	6	12	72
DV0501	DOOR SKIN	1	EA			1	3	6	36
DV0504	DOOR CHOKE V1	1	EA			1	3	6	36
SA104	DOOR ASSEMBLY V1	1	EA			1	1	2	12
SA111	DOOR ASSEMBLY V2 - V3	1	EA			1	3	6	36
SA183	402s HOT AIR MOTOR SERVICE KIT	1	EA		1	1	3	6	36
SA202	DOOR HINGE ASSEMBLY RH	1	EA			1	3	6	36
SA203	DOOR HINGE ASSEMBLY LH	1	EA			1	3	6	36
SA211	IMPINGER PLATE UPPER ASSY	1	EA			1	3	6	36
SA212	M/SWITCH BRACKET ASSY	2	EA			2	6	12	72
SA213	STIRRER ASSEMBLY	2	EA			2	6	12	72
SA217	MAINS LEAD ASSY (US)	1	EA		1	1	2	4	24
SA234	THERMISTOR SENSOR 50K NTC	2	EA	2	2	2	6	12	72
SA250	402s GREASE FILTER UPGRADE KIT	1	EA			1	3	6	36
SA251	402s CERAMIC COVER UPGRADE KIT	1	EA			1	3	6	36
SA252	TOOL KIT FOR SA251	1	EA			1	3	6	36
SA253	402s IMPINGER UPGRADE KIT	1	EA			1	3	6	36
SA254	402s WHISTLE STOP UPGRADE KIT	1	EA			1	3	6	36
SA257	EC402s SOUNDER ASSY	1	EA			1	3	6	36
SA266	IMPINGER PLATE LOWER ASSY	1	EA			1	3	6	36
SA276	AIR FILTER ASSY	2	EA	2	2	2	6	12	72
SA288	STIRRER MOTOR ASSY (PINNED)	1	EA		1	1	3	6	36
SA311	IMPELLER - HOT AIR MOTOR	1	EA			1	3	6	36
SA314	CATALYST ASSY UPPER (V1 - V2.5)	1	EA			1	1	2	12
SA315	CATALYST ASSY LOWER V1 - V2.5)	1	EA			1	1	2	12
SA329	REAR PANEL	1	EA			1	1	2	12
SA332	GASKET SET	1	EA			1	3	6	36
SA339	GREASE FILTER HOUSING	1	EA			1	1	2	12
SA340	GREASE FILTER CARTRIDGE	1	EA		1	1	2	4	24
SA351	CATALYST ASSY UPPER (V3)	1	EA			1	1	2	12
SA353	CATALYST ASSY LOWER (V3)	1	EA			1	1	2	12

APPENDIX 5: LOGIC PCB Connection Points and key features.

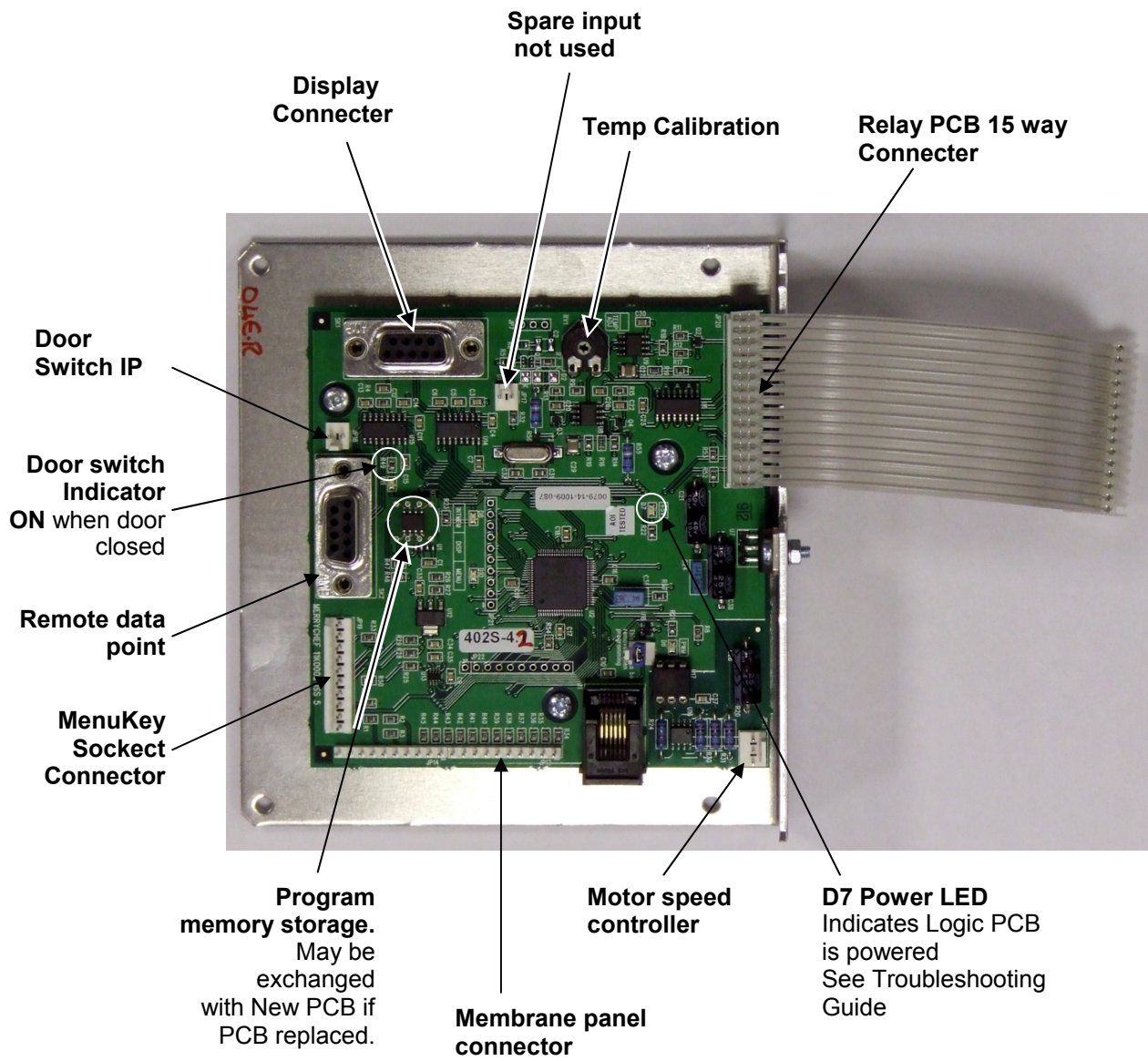

APPENDIX 5: Relay PCB Connection Points and key features.

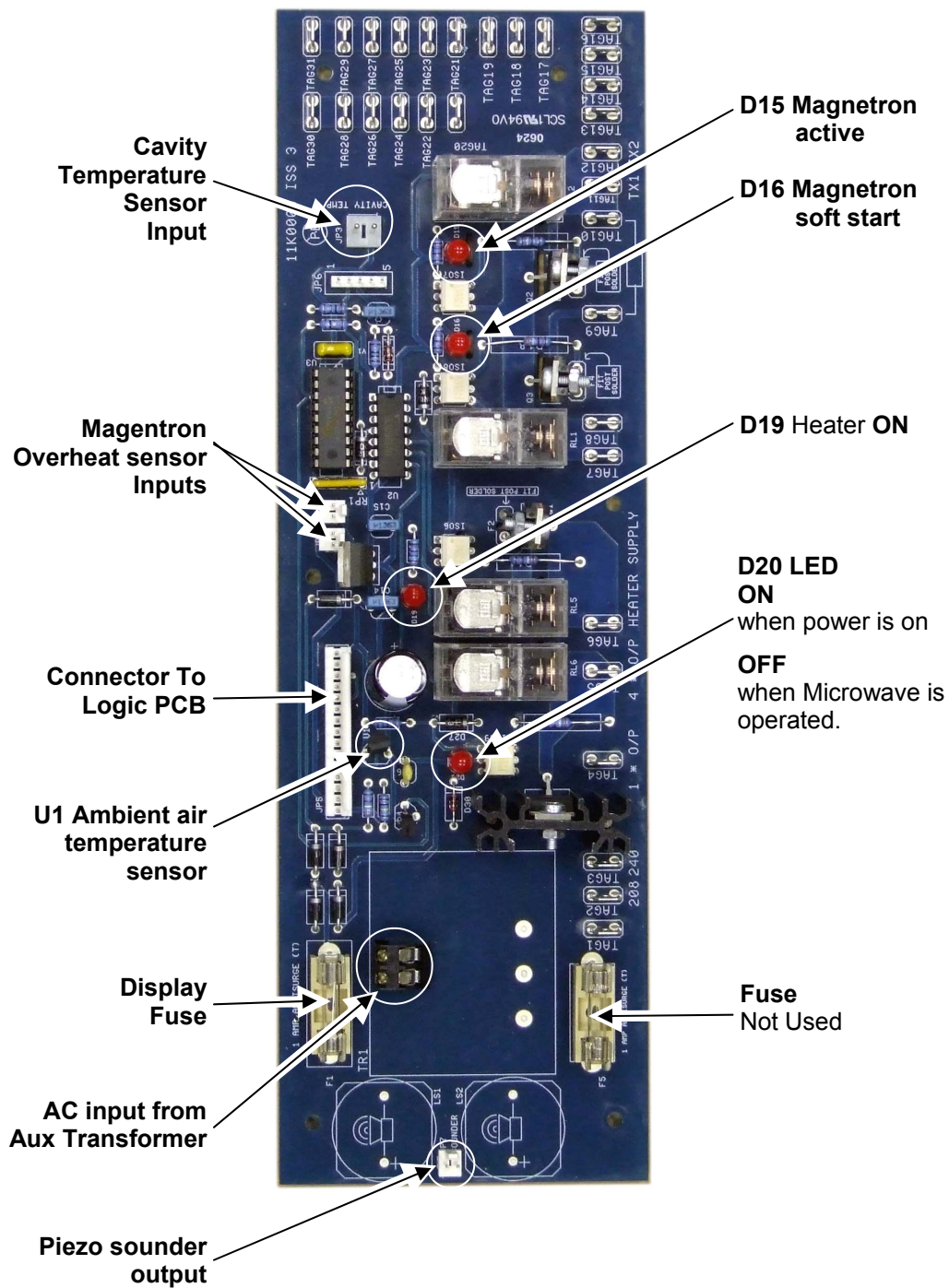

APPENDIX 6: Engineering Test Settings

Engineering Test Settings - Changing the Oven Profile

In order to carry out an oven test procedure the oven PREHEAT must be set to 0°F/OFF to switch off the convection heaters and the Manual controls must be enabled.

When the test is completed the oven must be returned to its original settings or the appropriate MenuKey can be used to reset the oven automatically.

To set the PREHEAT temperature to 0°F/OFF

402s Version 3.0 models

1. Switch the oven **OFF**
2. Switch **ON** and immediately press **Edit Preheat Temp.**

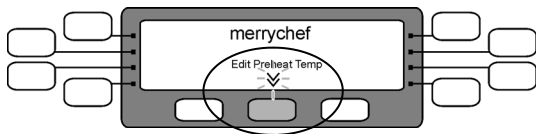

3. Make a note of the Preheat temperature in the display.

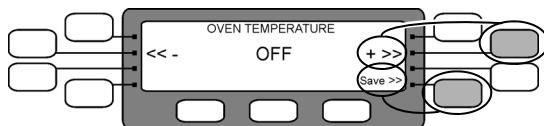

Press **+>>** for **OFF**
(note pressing either **+>>** or **<<-** will cycle through all the available temperatures)
Then Press **Save** to store this setting

402s Version 2.0/ 2.5

1. Switch the oven **OFF**
2. Switch **ON** and immediately press **Edit Preheat** to show the **ENTER PREHEAT TEMP** screen.

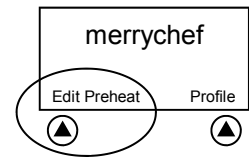

3. Make a note of the Preheat temperature in the display.

4. Press **0, 0, 0** to overwrite the current temperature setting.

Then press **Save** to store this setting

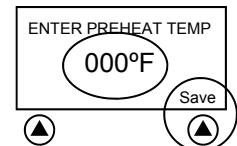

To set the Oven controls to allow Manual operation

1. Switch the oven **OFF** then
2. Switch **ON** and immediately press the lower right pad to display the **OVEN PROFILE** screen.

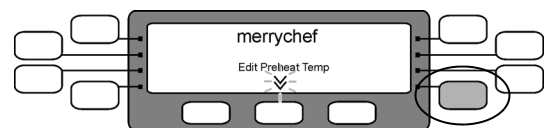

3. Press to set Manual Mode to **ON** Then Press **Save**

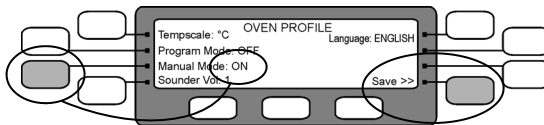

To use Manual Mode: from the **CATEGORIES** standby screen press the lower centre right pad To display the Manual mode screen.

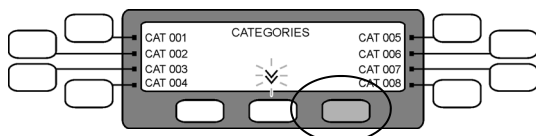

1. Switch the oven **OFF**
2. Switch **ON** and immediately press **Profile** to edit the oven operating profile

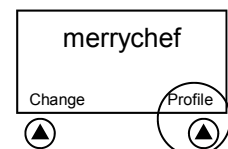

3. Press **Change** to set **OVEN MODE** to **PROGRAM/MANUAL**

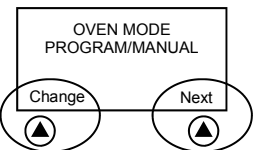

Then press **Next** five times to return to the **OVEN COLD** standby screen.

To use **MANUAL MODE**: from the **OVEN COLD/PRESS PREHEAT** standby screen press the **PREHEAT/COOL DOWN** pad on the control panel and then press **Manual**.

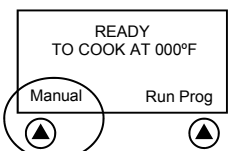

APPENDIX 7: Firmware revision guide.

As a result of on-going changes / upgrades to the 402s Oven, this Appendix has been produced stating the following:

- 1.0 An overview of the control system for a 402s.
- 2.0 How to check your Firmware version
- 3.0 How to check your hardware fitted
- 4.0 CODEKEY firmware upgrade
- 5.0 MenuKey2 download

CODEKEY Reference (See Table 1 for abbreviations description)

Version 3

- Part No. 31Z7066 3.0LD 402s Large Display UK/EU (FO / EMD)
- Part No. 31Z7068 3.0LD 402s Large Display French (FO / EMD)
- Part No. 31Z7071 4.3LD 402s Large Display UK/EU (FO / SSR / EMD)
- Part No. 31Z7072 4.3LD 402s Large Display French (FO / SSR / EMD)
- Part No. 31Z7073 4.4LD 402s Large Display US/EU
(FO / SSR / EMD / NSS / NPM / NEPT / NEP)
For QSR restaurants

Version 2.5

- Part No. 31Z7067 4.4SD 402s Small Display UK/EU (FO / EMD)

1.0 The 402s Control System

The control system of the 402s is based upon the following fundamentals:

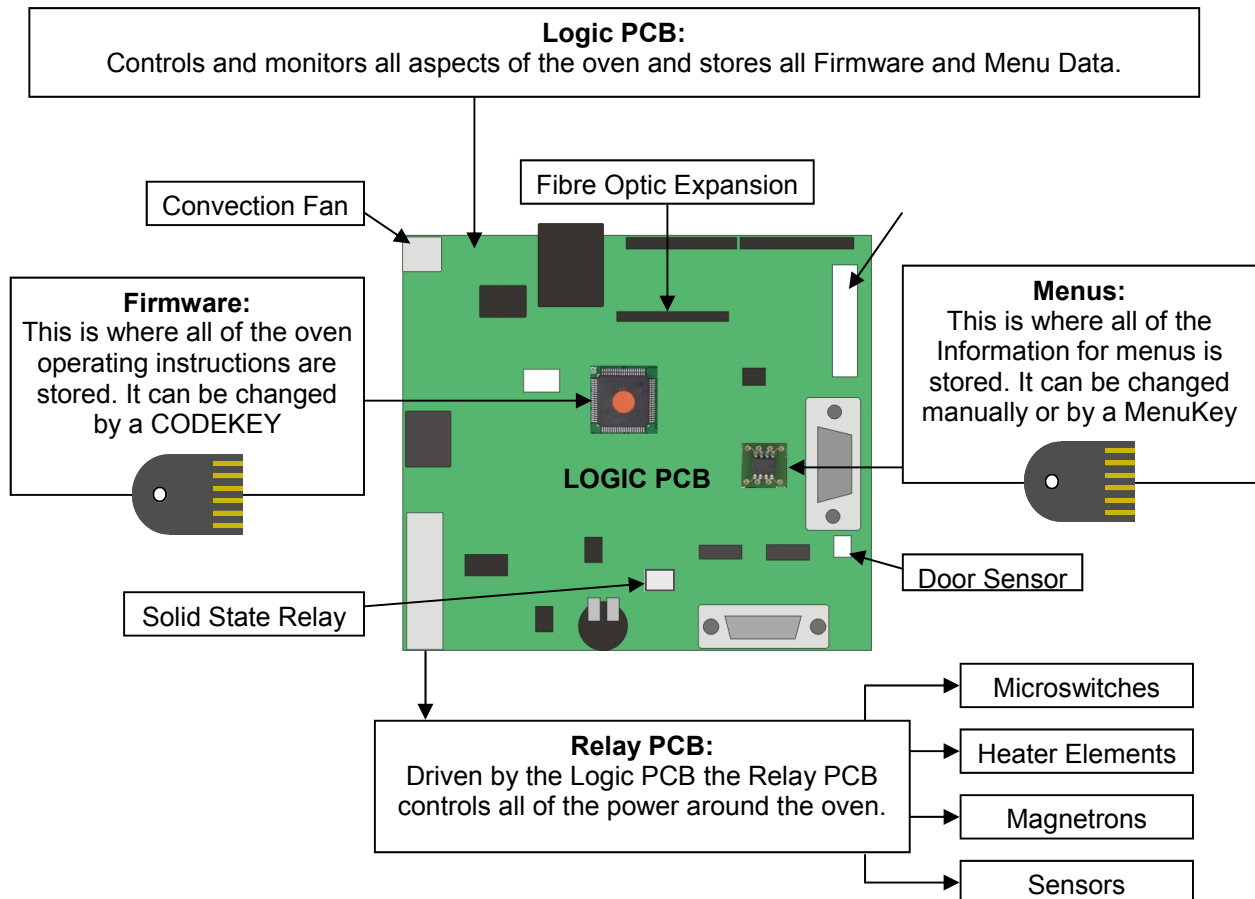

2.0 How to check your Firmware Version:

2.1 Power up the oven and verify the Firmware version that is loaded into the oven.

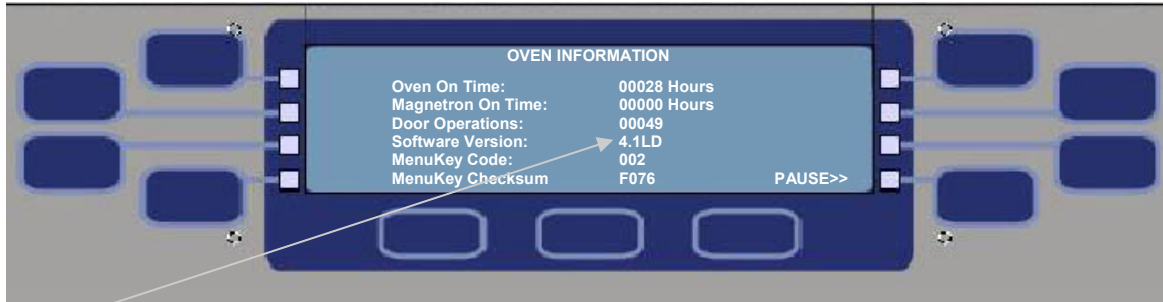

Check the Software Version on the Oven Start Up screen and refer to Table 1 below

Firmware Verification: Table 1								
Abbreviation Code	Firmware Features Supported	Firmware Version for 402s V3 ovens						
		2.8LD or lower	3.0LD	4.0LD	4.1LD	4.2LD	4.3LD GM	4.4LD QSR
-	Screen Saver	✓	✓	✓	✓	✓	✓	✗
NSS	No Screen Saver	✗	✗	✗	✗	✗	✗	✓
-	Edit Pre-Heat	✓	✓	✓	✓	✓	✓	✗
NEPT	Hidden Edit Pre-Heat	✗	✗	✗	✗	✗	✓	✗
-	Edit Profile	✓	✓	✓	✓	✓	✓	✗
NEP	Hidden Edit Profile	✗	✗	✗	✗	✗	✓	✗
-	Edit Programs	✓	✓	✓	✓	✓	✓	✗
NPM	Hidden Edit Programs	✗	✗	✗	✗	✗	✓	✗
FO	Magnetron Detect	✗	✓*	✓	✓	✓	✓	✓
EMD	Extended Mag Detect	✗	✓	✗	✗	✗	✓	✓
SSR	Solid State Relay	✗	✗	✓	✓	✓	✓	✓

Note: this Table excludes KFC France ovens.

*If Fibre Optic hardware is fitted.

Please also be aware of the store you are visiting as this would dictate what version of Firmware they would require. See below for clarification.	
CODEKEY Version 4.3LD or lower (GM ovens)	CODEKEY Version 4.4LD (QSR ovens)
All ovens except 'Quick Service Restaurants' Subway and KFC	'Quick Service Restaurants' only including Subway and KFC

Note: ALL ovens that are lower than 3.0LD Firmware should be up-lifted to version 3.0LD or higher depending on what hardware is fitted. (Refer to Table 2a & Table 2b)

3.0 How to check your hardware fitted:

3.1 Remove the oven lid to reveal the Logic PCB. See Table 2a below

TABLE 2A PCB Visual Check		Hardware fitted against PCB visual		Supports Oven Upgrade to V3	Allowable Version / Firmware
		SSR	Mag Detect		
Revision 1	 <p>No pin strip</p>	✘	✘	✘	ONLY ON V2 ovens 4.4SD
Revision 2	 <p>Pin strip fitted but no optics board</p>	✘	✘	✓	ON V2.5 ovens 4.4SD or higher ON V3 Ovens 3.0LD or higher

TABLE 2B Hardware Upgrade			
	Technical Bulletin Required		
	V2 oven	V2.5 oven	V3 oven
Adding Magnetron Detect	✘	TB114	TB114
Adding Solid State Relay	✘	TB122	TB122

Revision 3

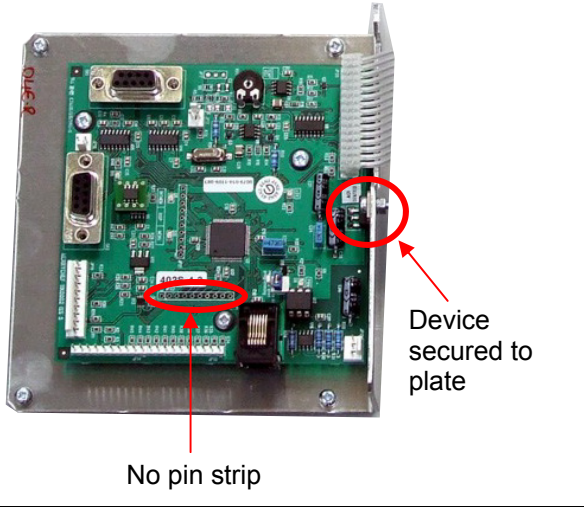
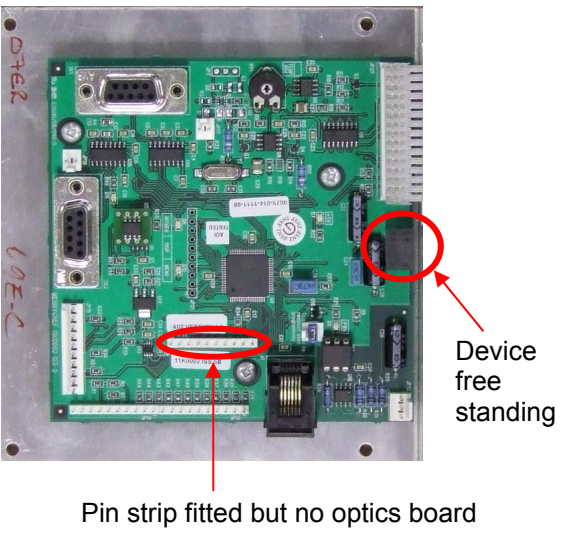
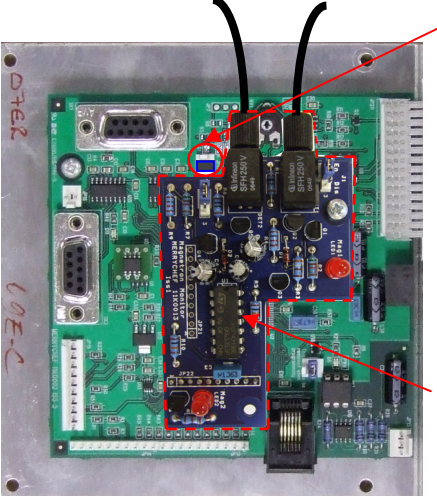
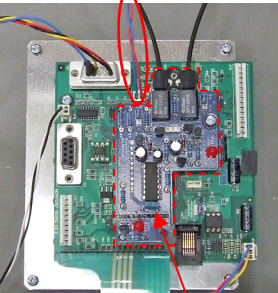

TABLE 2A		Hardware fitted against PCB visual		Supports Oven Upgrade to V3	Allowable Version / Firmware
		SSR	Mag Detect		
<p>PCB Visual Check</p>  <p>Blue jumper fitted</p> <p>Optics board fitted</p>		✗	✓	✓	<p>ON V2.5 ovens 4.4SD</p> <p>ON V3 ovens 3.0LD or higher</p>
<p>SSR lead</p>  <p>Fibre Optics Board + leads fitted</p> <p>SSR would be fitted if lead is present on PCB</p> 		✓	✓	✓	<p>ONLY ON V3 ovens 3.0LD or higher</p>

TABLE 2b: Hardware Upgrade			
Hardware Upgrade	Technical Bulletin Required		
	V2 oven	V2.5 oven	V3 oven
Adding Magnetron Detect	✗	TB114	TB114
Adding Solid State Relay	✗	TB122	TB122

4.0 CODEKEY Firmware upgrade

Procedure:

Before commencing an oven Firmware upgrade ensure the oven is switched off

- 4.1 Insert the appropriate CODEKEY (see Matrix 01 on page 2) into the Menukey receptacle on the control panel.

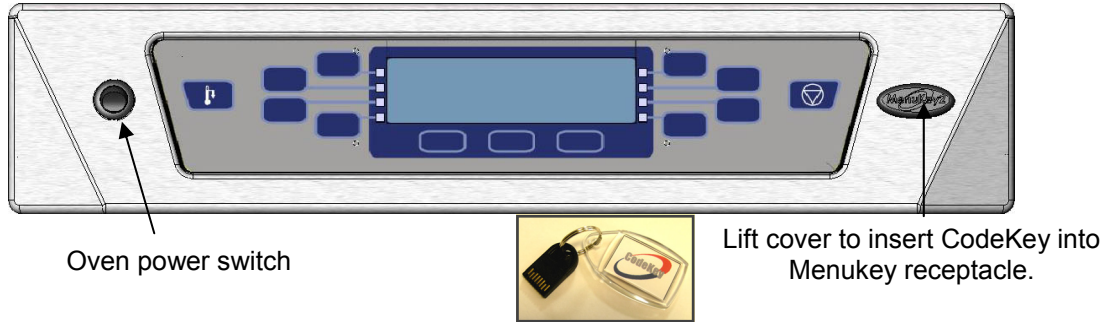

- 4.2 **Warning:**
During the next step the display will be blank for approximately 1 minute.
DO NOT REMOVE THE CODEKEY/ DO NOT TURN THE OVEN OFF
this will damage the logic board.

Switch the oven **ON** to activate the CodeKey, the screen will remain blank for approximately 1 minute before the startup screen displays.

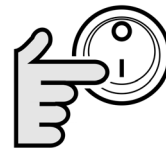

After 1 minute the Oven will boot-up immediately press the PAUSE pad to hold the oven information screen.

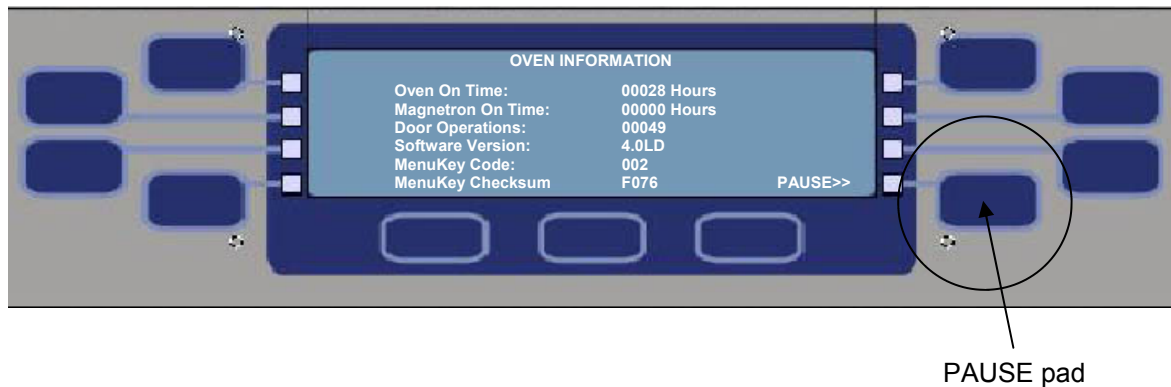

4.3 To confirm a successful download check that the Software Version on the oven and the CODEKEY fob Label are the same.

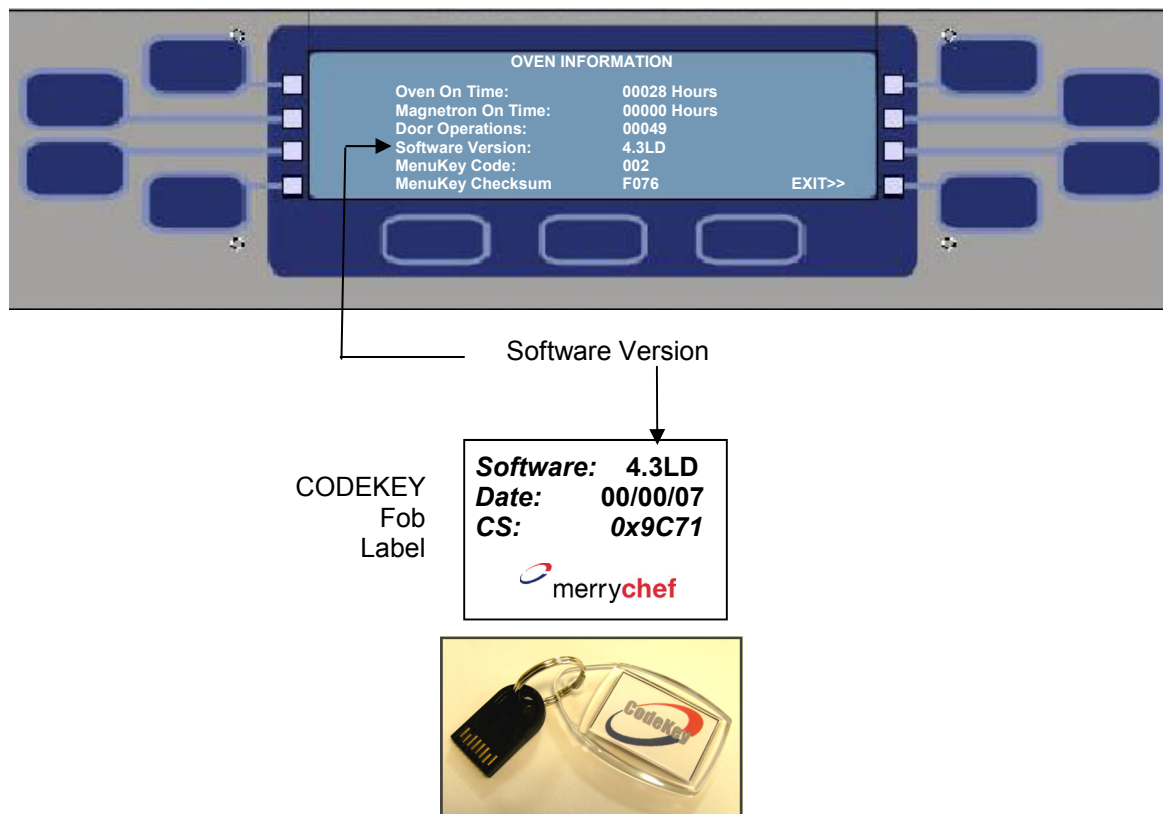

4.4 Press exit and remove and retain the CODEKEY.



5.0 MenuKey2 download

Procedure:

Before commencing a MenuKey download ensure the oven is switched OFF

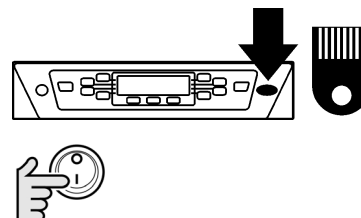
1. Insert the appropriate MenuKey into the control panel socket.
2. Switch the Oven **ON**
[DO NOT REMOVE the MenuKey as this will corrupt the data on the key]
3. The display will show the following:



MenuKey Detected Please Wait	Copying Programs from MenuKey to Oven 	Verifying Programs Copied successfully 	MenuKey Copied Successfully
---------------------------------	---	---	--------------------------------

4. The display will show the start up sequence and the Oven will begin heating up.
5. Remove the MENUKEY