



CDH HIGH TEMPERATURE Door-Type Dish Machine



SPECIFIER STATEMENT

Specified unit will be NSF rated, Centerline™ by Hobart high temperature door-type dishwasher. Features recirculating design, two selectable cycles, pumped rinse, pumped drain, 18" door opening, .73 gallons per rack, LED temperature and operator display, service diagnostics, interchangeable tri-prong wash and rinse arms. Constructed of stainless steel, rated at 51 racks per hour. 208-240/60/3/1 field convertible standard voltage.

1 year parts and labor warranty.

Project _____
AIA # _____ SIS # _____
Item # _____ Quantity _____ C.S.I. Section 114000

MODEL

CDH High temperature

STANDARD FEATURES

- + 51 racks per hour
- + .73 gallons of water per rack
- + High temperature sanitizing
- + Recirculating design
- + Top-mounted user interface with digital temperature display
- + Single point electrical connection standard
- + 3 phase standard, field convertible to single phase
- + 4-sided door
- + 1 standard cycle with optional extended cycle
- + 18" pillarless door opening
- + Tri-prong snap-in, revolving upper and lower anti-clogging wash & rinse arm; low-profile design
- + Removable, stainless steel scrap screen
- + Soft start
- + Automatic pumped drain
- + Pumped rinse
- + Automatic fill
- + Service diagnostics with error notifications
- + Delime notification and cycle
- + Electric tank heat
- + Straight through or corner installation

OPTIONS & ACCESSORIES (Available at extra cost)

- Chemical pumps
- Chemical sensing indicators (low chemical alert)
- Corner splash kit
- Water hammer arrestor kit
- Drain water tempering kit
- Pumped drain air gap kit
- Peg rack
- Combination rack
- Flanged feet

CDH HIGH TEMPERATURE

Approved by _____ Date _____ Approved by _____ Date _____

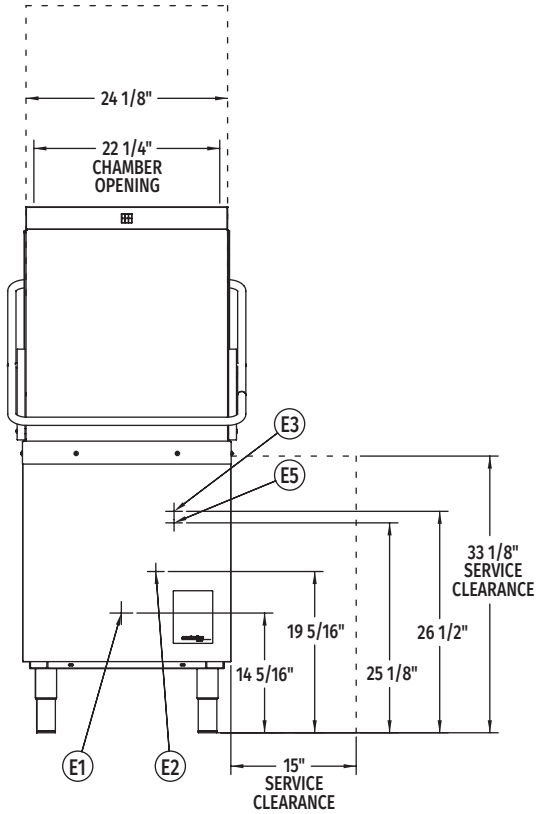

Front View

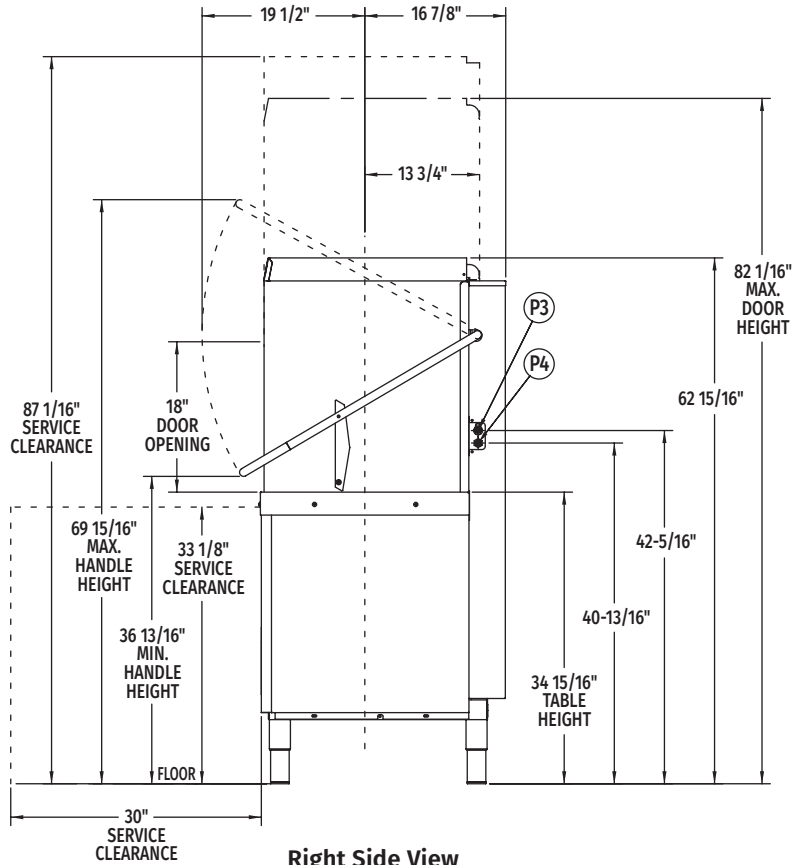

Right Side View

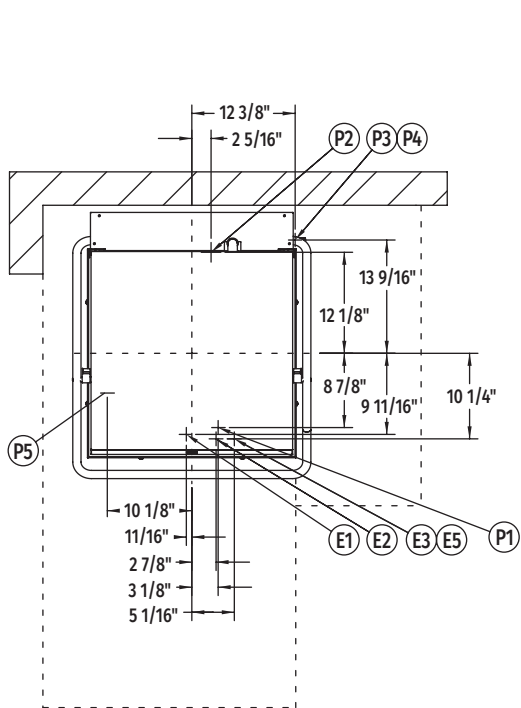

Top View

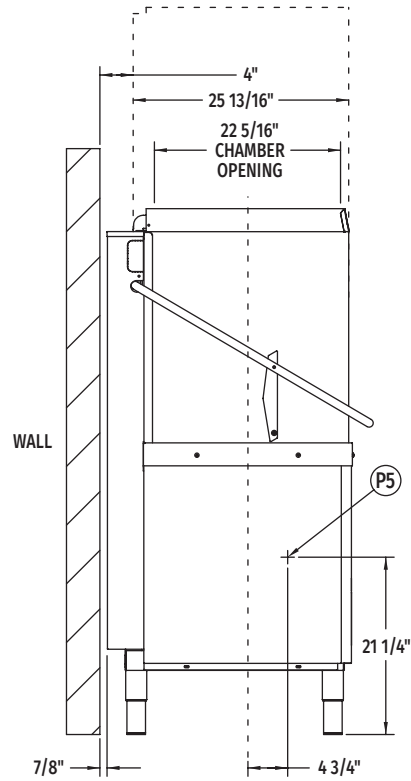

Left Side View

LEGEND

Electrical Connections	
E1	Electrical connection: 1-1/8" dia. hole for 1" trade size conduit; 8-3/4" AFF.
E2	Electrical connection: Detergent & rinse aid feeders, (DET1 & DET2) 1.5 amps @ 120V supply voltage, (RNS1 & RNS2) 1.5 amps @120V supply voltage; 19-5/16" AFF.
E3	Electrical connection: Vent fan control (VFC1 & VFC2) switching circuit only 1.5 amps @ nameplate supply voltage; 26-1/2" AFF.
E4	Electrical connection: Detergent & rinse aid sensor (optional); approximately 8-3/4" AFF.
E5	Electrical connection: Drain water tempering (optional), (DWT1 & DWT2) switching circuit only 1.5 amps @ nameplate supply voltage; 25-1/8" AFF.
Plumbing Connections	
P1	Single fill and rinse connection: 3/4" female garden hose fitting on 9' long hose supplied with machine; 120° F water minimum.
P2	Drain connection: 19mm barb fitting with 9' long hose supplied with machine.
P3	Chemical supply: Detergent. Approximately 42-5/16" AFF. 15mm barb fitting.
P4	Rinse agent feeder: Remove 1/8" NPT pipe plug to access 1/8" NPT tapped hole; 40-13/16" AFF.
P5	Detergent probe sensor: Remove cap and stud assembly to access 7/8" hole; 21-1/4" AFF.

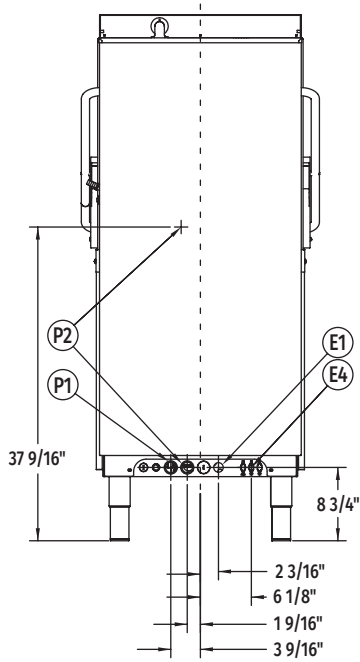

Back View

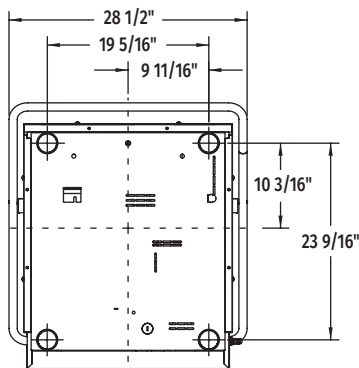

Bottom View

SPECIFICATIONS

Capacities

Racks per Hour (maximum)	51
Dishes per Hour (average 25 per rack)	1,275
Glasses per Hour (average 45 per rack)	2,295
Wash Tank (U.S. gallons)	7.9

Motor Horsepower

Rinse Pump	0.25
Wash Pump	0.80
Drain Pump	0.04

Rinse

Gallons per Rack	0.73
Gallons per Hour (maximum consumption)	37.2

Peak Rate of Drain Flow

Gallons per Minute (initial rate with full tank)	15
--------------------------------------------------	----

Heating

Electric Booster (kW)	6.5
Electric Heating Unit (kW)	5

Exhaust Requirements 450 CFM

Shipping Weight (approximate) 232 lbs.

Crated Dimensions 90.0"H x 30.0"W x 33.0"L

WARNING: Electrical and grounding connections must comply with the applicable portion of the National Electrical Code and/or other local electrical codes.

Plumbing connections must comply with applicable sanitary, safety, and plumbing codes.

CDH Single Point Electrical Service Connection as Shown Below

Elec. Specs	Rated Amps	Minimum Supply Circuit Ampacity	Maximum Protective Device
208/60/1	31.7	40	40
208/60/3	35.0	40	40
240/60/1	31.7	40	40
240/60/3	35.0	40	40

Plumbing Notes:

1. Water hammer arrestor (meeting ASSE-1010 standard or equivalent) to be supplied (by others) in common water supply line at service connection.
2. Recommended water hardness to be 3 grains or less for best results.
3. Recommended building flowing water pressure to the dishwasher at or above 20 PSI. Pressures lower than 20 PSI may affect machine fill/start-up times.
4. This is a pumped rinse machine. Pressure regulating valve is not necessary unless incoming flowing water pressure is greater than 65 PSI.
5. For convenience when cleaning, water tap should be installed near machine with heavy duty hose and squeeze valve.

Miscellaneous Notes:

1. All vertical dimensions taken from floor line may increase or decrease 1-1/4" depending on leg adjustment.
2. Vent hood (if required) to provide a minimum of 450 CFM exhaust (ref installation instructions).
3. Net weight of machine including booster: 210 lbs. Domestic shipping weight including booster: 232 lbs.
4. Size of racks – 19³/₄" x 19³/₄".

Approximate Heat Gain to Space without Vent Hood		
Type	Latent (BTU/Hr.)	Sensible (BTU/Hr.)
208/60/1	9,300	4,000
208/60/3	16,100	6,900
240/60/1	12,000	5,200
240/60/3	20,400	8,700

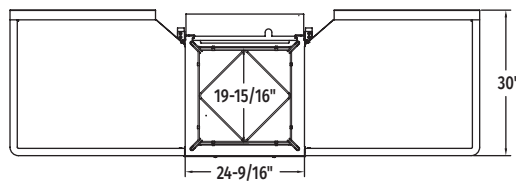

**PASS THRU
INSTALLATION**

TOP INSIDE VIEW OF MACHINE

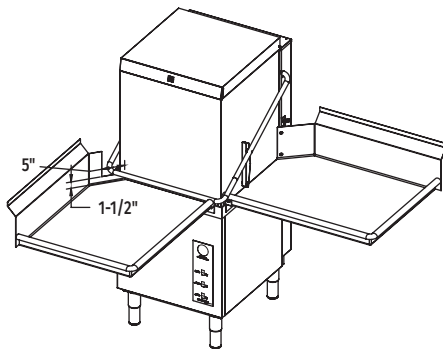

**CORNER
INSTALLATION**

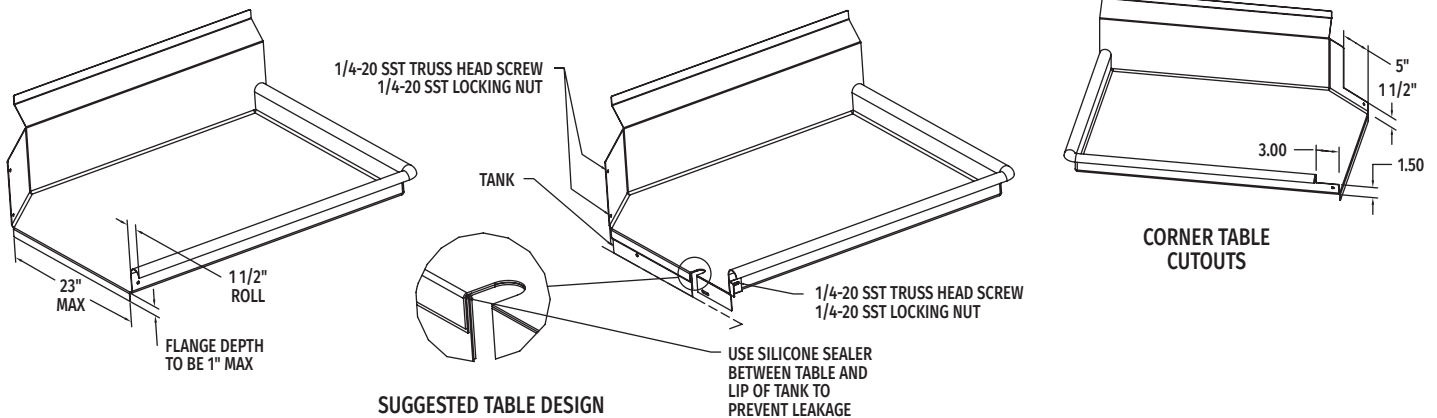
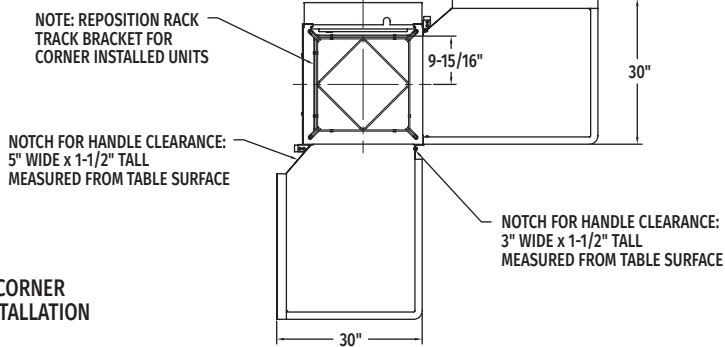

SUGGESTED TABLE DESIGN

**CORNER TABLE
CUTOUTS**