

ZAXIS160



HYDRAULIC EXCAVATOR

Model Code : ZX160LC-5B

Engine Rated Power : 90.2 kW

Operating Weight ZX160LC-5B : 16 600 - 18 500 kg

Backhoe Bucket ISO Heaped : 0.52 - 0.82 m³



WALK AROUND

CONTENTS

4-5 Performance

Enhanced power, torque and speed ensure the optimum performance of every Hitachi machine.

6-7 Productivity

The new ZAXIS have a high impact on efficiency but a low impact on the environment.

8-9 Comfort

The cab of the new ZAXIS provides a safer and comfortable work space.

10-11 Durability

Hitachi is renowned for manufacturing high-quality machines that can meet the demands of the toughest job sites.

12-13 Maintenance

Easily accessible features for cleaning and routine maintenance maximise the availability of the ZAXIS 160.

14-15 Hitachi Support Chain

A wide range of after-sales services and support options is available to all our customers.

16-21 Specifications

Higher productivity

The HIOS III hydraulic system achieves higher productivity with better fuel consumption than the conventional ZAXIS model, which helps to reduce costs.

Added durability

The strengthened brackets on the boom end and foot are equipped with bushings to withstand rugged environments.

Faster movement

The arm recirculation cancel and hydraulic boosting systems increase the arm speed during operation.

Enhanced versatility

The attachment support system allows for the easy installation of attachments.



ZAXIS Empower your Vision.

The design of the new Hitachi ZAXIS 160 medium excavator is inspired by one aim – empower your vision. It delivers on five key levels: performance, productivity, comfort, durability and reliability. We recognise that fleet owners require high-quality, efficient machines that can work effectively, even in challenging conditions. We also realise that operators need a safer, user-friendly work space, and a machine that can respond to their skills with speed and precision. And to achieve a satisfying result, on time, on budget and to a high standard, we have aimed to maximise availability of the new ZAXIS 160 with easy maintenance features and the Hitachi Support Chain after-sales programme.

Expanded leg room

The seat and console can slide further back on the new ZAXIS, providing a more comfortable working environment for the operator. The right side console has been ergonomically re-designed.

Ultimate comfort

The heated air suspension seat is ideal in cold climates and absorbs vibration during operation minimising operator fatigue.

Easily accessible information

The large multi-function LCD monitor screen is easy to view in bright sunlight or darkness and provides technical data.

Quick and easy service access

The air conditioning condenser can be easily opened for cleaning the condenser and radiator. Inspection parts are conveniently located.



NOTE : The photo in this brochure show excavators with optional equipment.



PERFORMANCE

The powerful ZAXIS 160 has been designed to deliver an outstanding level of performance, but with lower fuel consumption than its predecessor. Its enhanced hydraulics ensure a smooth, fast and precise operation on any earth-moving or construction site, helping you to increase production and meet targets successfully. Reduced fuel consumption will have a direct impact on your running costs and overall profitability, allowing you to make a quick return on your initial investment.



Enhanced power and speed set a new standard on the job site



Lower fuel with high productivity

Winning tenders and meeting production targets are highly competitive processes for you to develop your business. The choice of construction machinery is of paramount importance and your success relies on the productivity and efficiency of your equipment.

The latest advanced hydraulic and electronic technologies are central to our goal of delivering a significant saving on fuel costs with the new low-emission engine. We are delighted that HIOS III hydraulics allow you to achieve 14% less fuel consumption in PWR mode – than the previous ZAXIS P-mode – while maintaining a high level of productivity at the same time*.

Furthermore, a reduction of 37% in fuel consumption is also possible in ECO mode*. This still delivers a relatively high level of productivity using the same amount of fuel.

Higher level of performance

The success of your business is influenced by the productivity and efficiency of your equipment. Ultimately, your investment in Hitachi construction machinery can help you to meet production targets and compete successfully to win tenders within your market.

The hydraulic boosting system and other hydraulic systems enable the arm roll-in speed to increase when the load is relatively low. Our tried-and-tested power-boost feature has also increased by 10% to deliver an enhanced level of excavating performance and lifting power.

The versatility of the ZAXIS 160 may be evidenced by the attachment support system, with 11 modes that can be registered on the monitor for the easy fitment of different attachments.

** Based upon typical work pattern collected via Global e-Service*

Key features

■ 14% reduction in fuel consumption (PWR mode vs ZX-3 P-mode)*

■ 37% reduction in fuel consumption (ECO mode vs ZX-3 P-mode)*

■ HIOS III hydraulic system – high productivity and lower fuel consumption

■ Attachment support system

■ Power-boost



PRODUCTIVITY

The new ZAXIS medium excavators may have a smaller impact on the environment, but they also have a greater impact on productivity levels. Designed with a variety of powerful and innovative features, the new ZAXIS 160 can help to increase production on any job site in an efficient and sustainable way. This results in a cleaner, quieter working environment and a healthier profit for your business.



Striking a balance between powerful and sustainable efficiency



Sustainable efficiency

We are dedicated to the sustainable development of the Hitachi product range, particularly for use on urban job sites. Therefore, the new ZAXIS 160 is a sign of our commitment to minimising the impact of construction machinery on the environment in compliance with EU emission control Stage IIIB.

The ZAXIS 160 has been fitted with a muffler filter to capture air pollutants, which is automatically burnt thanks to an oxidation catalyst and exhaust temperature control. The variable geometry turbocharger and high volume-cooled EGR (Exhaust Gas Recirculation) also help to reduce nitrous oxide levels.

As well as reducing emissions, the ZAXIS 160's Auto Shut-down helps to prevent fuel wastage and lowers the level of noise in the cab.

In addition, all resin parts on the new ZAXIS medium excavator range are suitable for recycling and clearly marked for ease of use in this process.

Powerful efficiency

We are also focusing on finding the right balance between people, planet and profit. So, we have assessed the total cost of ownership for the new ZAXIS 160 to ensure that your new machine contributes to the profitability of your business.

The powerful new-generation Stage IIIB-compliant engine in the ZAXIS 160 delivers higher productivity, with greater fuel efficiency and is fitted with state-of-the-art controls throughout all of the components.

Hitachi medium excavators are renowned for their powerful and reliable performance, especially when there are daily targets and ultimate deadlines to meet on busy job sites. The latest range of ZAXIS models have been designed for increased productivity without burdening the environment through sustainable operations.

Key features

- Powerful and sustainable
- Stage IIIB-compliant engine
- Muffler filter that captures particulate matter
- Variable geometry turbocharger
- High volume-cooled EGR system
- Environmentally friendly design
- Auto Shut-down – fuel saving for carbon dioxide reduction



COMFORT

A comfortable working environment is a top priority for owners and operators, so we aimed to design a cab for the new ZAXIS medium excavator range that would reflect their requirements and exceed their expectations. With excellent all-round visibility, ample leg room and a range of user-friendly features, the cab of the ZAXIS 160 is safe and spacious, helping you to feel in complete control.



Inside and out, the new ZAXIS medium excavators lead the way



From the comfort of the cab

After a long shift on a road construction site or in the quarry, you need to feel ready to enjoy the rest of your day. Hitachi has taken the lead in operator comfort with the new ZAXIS 160, so that you can do just that.

The adjustable air-suspension seat features a new sliding mechanism with the capacity to be moved back further than ever before. The space underneath the monitor has also been expanded to allow for more leg room. The pressurized cab keeps dust and particles from entering.

All-round visibility

Busy construction sites demand your full attention to avoid unnecessary damage or health and safety issues. The enhanced visibility – especially down the right-hand side of the new ZAXIS – will also save you time (and money), thanks to the latest innovations from Hitachi.

The repositioning of the monitor and door enhances your view, as well as making access to and from the cab much easier. The latest rear-view camera offers a closer view of the counterweight to reduce the blind spot.

User-friendly functionality

Hitachi has invested heavily in the advanced technology inherent within the new ZAXIS. The power remains firmly at your fingertips thanks to the functionality of the colour monitor and ergonomic controls.

The new multi-function LCD monitor has a large seven-inch screen that is easy to view. It provides a wide range of useful technical information, including a clear indication of the machine's status and settings with multi-lingual support in up to 32 languages. The monitor and ergonomically designed switches have been grouped together within easy reach of your right hand. The proportional switch in the new, optional, auxiliary function lever allows easy control of the front attachment.

Enjoy your work

Time flies when you're having fun, but we also realise that a happy operator is also a more productive one. That's why we have renewed our focus on providing a relaxed and enjoyable working environment within the cab.

The controls for the AM/FM stereo radio are now adjustable from the colour monitor. An auxiliary terminal has also been added to the sound system, so that you can work efficiently and smoothly to your favourite music via devices such as MP3 players and the inclusion of storage for an MP3 player.

Key features

- High-spec ROPS pressurised cab
- Enhanced visibility
- New colour LCD monitor
- Easily accessible real-time information

- Expansive leg room
- Ergonomically designed control panel
- Auxiliary terminal and storage for an MP3 player



DURABILITY

Several decades of manufacturing high-quality construction equipment has given Hitachi unrivalled expertise in developing machines that can cope with the toughest job sites and most challenging projects. The new ZAXIS medium excavator range is a perfect example and incorporates the latest advancements in technology. So you can be assured of its reliability and durability for even the most difficult working conditions.



Build to conquer tough working environments



Durable parts

The new ZAXIS 160 has been designed to operate in the most challenging of working conditions. Tough job sites require reliable machines, which deliver increased levels of availability and productivity. The bottom line is that you will enjoy a lower cost of ownership thanks to the durability of our medium excavators.

The strengthened boom end and foot on each new ZAXIS 160 are good examples. The brackets on the boom end and foot have been equipped with bushings to enhance their durable characteristics and withstand the rigours of long hours in rugged environments.

A filter-type high-performance water separator is provided standard. It captures moisture in fuel, even from fuel which contains a large amount of moisture.

Reinforced undercarriage

The front idler and adjuster cylinder have been reinforced on the ZAXIS 160 for added durability. In addition, mud no longer sticks to the adjuster cylinder.

Reliability has been further addressed with increase in the welded section parts that comprise the X-beam. The travel motor brackets' upper and lower plates have been extended, which has delivered a 40% reduction in stress.

ROPS-compliant cab

The pressurised and ROPS-compliant CRES V (Center pillar reinforced structure) cab prevents the penetration of dust and protects you from the potential risks of the job site. The Roll-over Protective Structure (ROPS) is designed to protect the operator in the unlikely event of the machine tipping or rolling over.

Key features

- Proven Hitachi quality
- More than 40 years of expertise
- Strengthened front attachment
- Reinforced undercarriage



MAINTENANCE

The new ZAXIS 160 has been designed to enable you to carry out quick and convenient maintenance and service checks, guaranteeing higher availability and greater reliability of your machine. Many features are easily accessible from ground level and some have been repositioned, making it simpler and less time-consuming to perform routine maintenance and cleaning procedures. This means you can spend more time doing the work you really enjoy.



Keep working for longer thanks to user-friendly accessible features



Easy access

We have made life easier for you by introducing a range of convenient features integrated within the new ZAXIS range of medium excavators. Our engineers have assessed your requirements and integrated a number of time-saving factors for routine maintenance.

Using the technology within the multi-function LCD monitor you can check engine oil volumes and see the warning light that appears when the hydraulic oil and fuel filters are due for replacement. In addition, you can set the routine service schedule to help prevent breakdowns each time the ignition switch is turned on.

On the exterior of the ZAXIS 160, the air conditioning condenser can be easily opened for cleaning the condenser and radiator. Severe blockages can also be cleared by blowing air through the convenient one-touch openable upper cover above the radiator.

From ground level, you can replace the fuel filters, engine oil filter and air cleaner, and other work is aided by non-slip steps for easy access to the upper structure of the machine.

Easy cleaning

We believe that easy routine maintenance enhances the levels of productivity and availability for your machine. That's why we have designed the ZAXIS 160 with a series of convenient and quick solutions, so that you can enjoy long, trouble-free days on the job site.

The interior anti-dust filter is a good example of these initiatives. It has been placed on the outside of the air conditioning condenser and fuel cooler, and away from the fan so that dust and particles can be caught evenly without them collecting in one place.

The cooling package has been placed in parallel and the slanted side frame also aids the cleaning process.

Key features

- Global e-Service monitors muffler filter
- Daily checks from ground level
- Oil volumes checked from the operator's seat
- Quick and easy service access



SUPPORT CHAIN

As soon as you become a Hitachi customer, you can rely on first-class after-sales service from your authorised dealer. Hitachi provides extensive support to each of the dealers within the Australian network, so that they can ensure your ZAXIS 160 continues to meet your requirements and exceed expectations. To further protect your investment in Hitachi construction machinery, we have introduced the Hitachi Support Chain after-sales programme. This gives you the flexibility to create a tailor-made service plan from the following key-areas, "links" in the chain of service available from Hitachi via your local dealer.



A flexible after-sales programme created to protect your investment

Global e-Service

The new ZAXIS excavator is equipped with a GPRS communication system*. This sends a wide range of machine data to the Hitachi main server. Via the Global e-Service database, you will have remote access to all of this data. All you need is an internet connection and your Global e-Service log-in details.

Global e-Service enables you and your dealer to download and share this data, helping you to remotely manage your fleet. The online facility also helps your dealer to proactively advise you on preventive maintenance and related special offers.

The latest information on the ZAXIS excavator is available 24/7 and includes operational data, such as the number of working hours, fuel consumption figures, working modes and location. This helps you to reduce running costs, plan jobs efficiently and keep up to date with machine maintenance – to ensure optimum performance and minimal downtime.

Technical support

The professional and highly trained Hitachi service team combines the global expertise and knowledge of Hitachi Construction Machinery with your local language and culture. We take a proactive approach towards customer service by continuously training our dealer personnel, so that the available global knowledge is passed on to each individual technician in our dealer network.

Extended warranty and service contracts

Every new Hitachi model is covered by a full manufacturer's warranty. However, your ZAXIS excavator may require extra protection due to severe working conditions or to reduce equipment repair costs. To meet these demands, our dealers offer the option of a unique extended warranty programme (HELP – Hitachi Extended Life Program) and comprehensive service contracts – the most effective way to optimise the performance of your new ZAXIS excavator.

Parts and remanufactured components

Hitachi offers different lines of parts and components to suit your specific needs. In addition to our range of genuine parts, there are other options available:

- If your machines have been working for several years, Hitachi can offer a second line of genuine parts as an attractively priced solution.
- For that highly demanding application or climate, Hitachi provides a line of parts with extra performance.
- When you are looking for an economical solution for preventive replacements, remanufactured components are the best option.

Whatever choice you make, you can be assured of the renowned Hitachi quality and warranty to give you added peace of mind.

Your Hitachi dealer can supply you with more details on each of the above parts lines.



* The GPRS communication system is standard equipment for new ZAXIS excavators, however, the availability of the communication system depends on licensing regulations in your country. Please contact your Hitachi dealer for more information or to apply for a Global e-Service account.

Key features

- Check each of your machines from your office – 24/7
- Have a remote insight into fuel consumption
- Check the current and previous locations and movements of your machine(s)

- See maintenance status and items due for renewal on each of your machines
- Receive e-mail notifications for any machine alerts, unexpected movements and so on

SPECIFICATIONS

ENGINE

Model	Isuzu AM-4JJ1X
Type	4-cycle water-cooled, common rail direct injection
Aspiration	Variable geometry turbocharged, intercooled, cooled EGR
After treatment	Muffler filter
No. of cylinders	4
Rated power	
ISO 14396	95.0 kW at 2 200 min ⁻¹
ISO 9249, net	90.2 kW at 2 200 min ⁻¹
EEC 80/1269, net	90.2 kW at 2 200 min ⁻¹
SAE J1349, net	90.2 kW at 2 200 min ⁻¹
Maximum torque	406 Nm at 1 800 min ⁻¹
Piston displacement	2.999 L
Bore and stroke	95.4 mm x 104.9 mm
Batteries	2 x 12 V / 74 Ah

HYDRAULIC SYSTEM

Hydraulic Pumps

Main pumps	2 variable displacement axial piston pumps
Maximum oil flow	2 x 191 L/min
Pilot pump	1 gear pump
Maximum oil flow	33.6 L/min

Hydraulic Motors

Travel	2 variable displacement axial piston motors
Swing	1 axial piston motor

Relief Valve Settings

Implement circuit	34.3 MPa
Swing circuit	29.3 MPa
Travel circuit	34.3 MPa
Pilot circuit	3.90 MPa
Power boost	38.0 MPa

Hydraulic Cylinders

	Quantity	Bore	Rod diameter
Boom	2	110 mm	80 mm
Arm	1	120 mm	90 mm
Bucket	1	105 mm	75 mm

UPPERSTRUCTURE

Revolving Frame

D-section frame for resistance to deformation.

Swing Device

Axial piston motor with planetary reduction gear is bathed in oil. Swing circle is single-row. Swing parking brake is spring-set/hydraulic-released disc type.

Swing speed	13.3 min ⁻¹
Swing torque	44 kNm

Operator's Cab

Independent spacious cab, 1 005 mm wide by 1 675 mm high, conforming to ISO* Standards.

* International Organization for Standardization

UNDERCARRIAGE

Tracks

Heat-treated connecting pins with dirt seals. Hydraulic (grease) track adjusters with shock-absorbing recoil springs.

Numbers of Rollers and Shoes on Each Side

Upper rollers	2
Lower rollers	7
Track shoes	43
Track guard	1

Travel Device

Each track driven by 2-speed axial piston motor. Parking brake is spring-set/hydraulic-released disc type. Automatic transmission system: High-Low.

Travel speeds	High : 0 to 5.3 km/h
	Low : 0 to 3.4 km/h

Maximum traction force ... 169 kN

Gradeability

70% (35 degree) continuous

SOUND LEVEL

Sound level in cab according to ISO 6396	LpA 70 dB(A)
External sound level according to ISO 6395 and EU Directive 2000/14/EC	LwA 100 dB(A)

SERVICE REFILL CAPACITIES

Fuel tank	320 L
Engine coolant	22.0 L
Engine oil	17.0 L
Swing device	6.20 L
Travel device (each side)	6.80 L
Hydraulic system	210 L
Hydraulic oil tank	125 L

WEIGHTS AND GROUND PRESSURE

Operating Weight and Ground Pressure

Shoe type	Shoe width	Arm length	ZAXIS 160LC		ZAXIS 160LC with blade (optional)	
			kg	kPa	kg	kPa
Triple grouser	500 mm	2.22 m	16 600	48	18 500	54
		2.58 m	16 600	48	18 500	54
	600 mm	2.22 m	16 800	40	–	–
		2.58 m	16 800	40	–	–
	700 mm	2.22 m	17 000	35	–	–
		2.58 m	17 100	35	–	–

Including 0.60 m³ (ISO heaped), bucket weight (500 kg) and counterweight (3 200 kg).

Basic Machine Weight and Overall Width

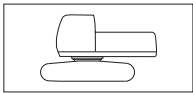

Excluding front end attachment, fuel, hydraulic oil and coolant etc. Including counterweight.

Shoe width	ZAXIS 160LC		ZAXIS 160LC with blade (optional)	
	Weight	Overall width	Weight	Overall width
500 mm	13 100 kg	2 500 mm	15 000 kg	2 500 mm
600 mm	13 400 kg	2 590 mm	–	–
700 mm	13 600 kg	2 690 mm	–	–

Components Weight

	Weight
Counterweight	3 200 kg
Boom 5.10 m (with arm cylinder and boom cylinder)	1 620 kg
Arm 2.22 m (with bucket cylinder)	770 kg
Arm 2.58 m (with bucket cylinder)	800 kg
Bucket 0.60 m ³	500 kg

BUCKET AND ARM DIGGING FORCE

Arm length	ZAXIS 160LC	
	2.22 m	2.58 m
Bucket digging force* ISO	112 kN	
Bucket digging force* SAE	99 kN	
Arm crowd force* ISO	115 kN	91 kN
Arm crowd force* SAE	110 kN	88 kN

* At power boost

BACKHOE ATTACHMENTS

Boom and arms are of welded, box-section design. 5.10 m boom, and 2.22 m, 2.58 m arms are available. Bucket is of welded steel structure. Side clearance adjust mechanism provided on the bucket joint bracket.

Buckets

Capacity	Width		No. Of teeth	Weight	Recommendation	
					ZAXIS 160LC	
	Without side cutters	With side cutters			Arm 2.22 m	Arm 2.58 m
0.52 m ³	790 mm	910 mm	4	470 kg	⊙	⊙
0.60 m ³	925 mm	1 050 mm	5	500 kg	⊙	⊙
0.70 m ³	1 010 mm	1 130 mm	5	535 kg	⊙	○
0.82 m ³	1 140 mm	1 260 mm	5	580 kg	○	□

⊙ Suitable for materials with density of 2 000 kg/m³ or less

○ Suitable for materials with density of 1 600 kg/m³ or less

□ Suitable for materials with density of 1 100 kg/m³ or less

– Not applicable

SPECIFICATIONS

WORKING RANGES

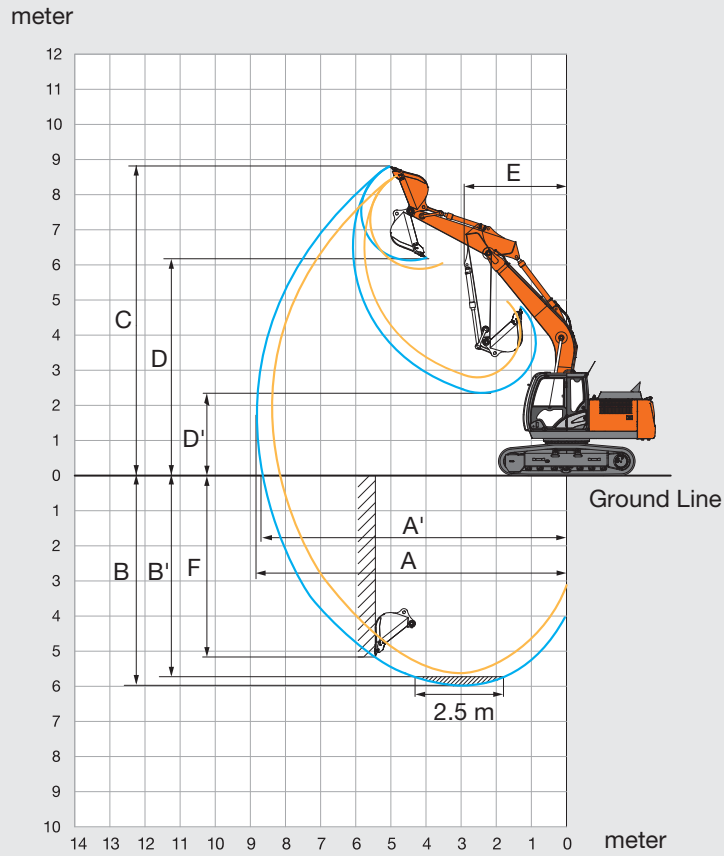

Unit: mm

	ZAXIS 160LC	
Arm length	2.22 m	2.58 m
A Max. digging reach	8 520	8 870
A' Max. digging reach (on ground)	8 340	8 700
B Max. digging depth	5 620	5 980
B' Max. digging depth (2.5 m level)	5 340	5 740
C Max. cutting height	8 620	8 880
D Max. dumping height	5 940	6 170
D' Min. dumping height	2 750	2 380
E Min. swing radius	3 290	2 910
F Max. vertical wall digging depth	4 510	5 160

Excluding track shoe lug

DIMENSIONS

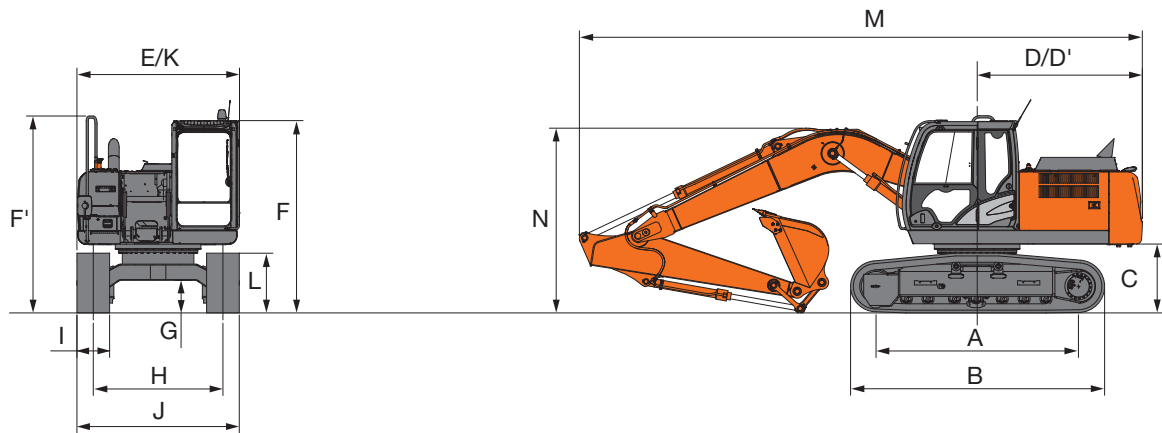

BLADE (OPTIONAL)

Unit: mm

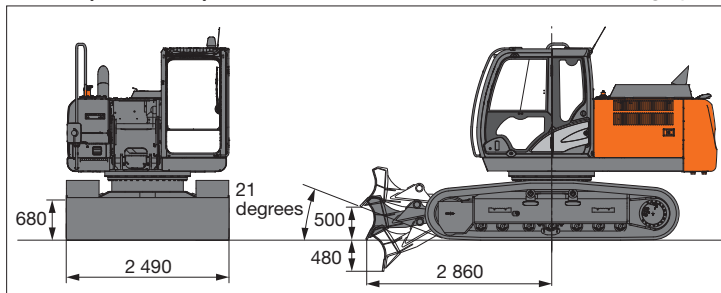

Unit: mm

	ZAXIS 160LC	ZAXIS 160LC with blade (optional)
A Distance between tumblers	3 100	
B Undercarriage length	3 920	
* C Counterweight clearance	1 030	
D Rear-end swing radius	2 550	
D' Rear-end length	2 530	
E Overall width of upperstructure	2 480	
F Overall height of cab	2 950	
F' Over height of upperstructure	3 010	
* G Min. ground clearance	470	
H Track gauge	1 990	
I Track shoe width	G 500	
J Undercarriage width	2 490	
K Overall width	2 500	
* L Track height with triple grouser shoes	920	
M Overall length		
With arm 2.22 m	8 720	9 050
With arm 2.58 m	8 620	8 950
N Overall height of boom		
With arm 2.22 m	3 190	
With arm 2.58 m	2 870	

* Excluding track shoe lug G: Triple grouser shoe

LIFTING CAPACITIES

- Notes: 1. Ratings are based on ISO 10567.
 2. Lifting capacity does not exceed 75% of tipping load with the machine on firm, level ground or 87% full hydraulic capacity.
 3. The load point is the center-line of the bucket pivot mounting pin on the arm.
 4. *Indicates load limited by hydraulic capacity.
 5. 0 m = Ground.

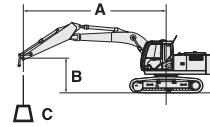

A: Load radius
 B: Load point height
 C: Lifting capacity

For lifting capacities, subtract bucket and quick hitch weight from lifting capacities without bucket.

ZAXIS 160LC

Rating over-front Rating over-side or 360 degrees Unit : kg

Conditions	Load point height m	Load radius								At max. reach		
		1.5 m		3.0 m		4.5 m		6.0 m		meter		
Boom 5.10 m	4.5					*4 980	*4 980	*4 600	3 270	4 340	2 870	6.51
Arm 2.22 m	3.0					*6 270	4 770	4 810	3 150	3 830	2 520	6.97
Counterweight	1.5					7 170	4 460	4 660	3 020	3 660	2 390	7.08
3 200 kg	0 (Ground)					6 990	4 300	4 560	2 920	3 770	2 450	6.87
Shoe 500 mm	-1.5			*11 720	7 890	6 960	4 270	4 550	2 910	4 260	2 740	6.30
	-3.0			*10 440	8 060	7 070	4 370			5 620	3 570	5.25
Boom 5.10 m	6.0							*3 300	*3 300	*3 150	*3 150	6.05
Arm 2.58 m	4.5					*4 560	*4 560	*4 290	3 300	*3 080	2 630	6.89
Counterweight	3.0			*8 860	*8 860	*5 870	4 830	4 840	3 170	*3 190	2 330	7.33
3 200 kg	1.5					7 230	4 510	4 680	3 020	3 410	2 220	7.44
Shoe 500 mm	0 (Ground)			*6 270	*6 270	7 000	4 310	4 560	2 920	3 490	2 260	7.23
	-1.5	*5 740	*5 740	*10 420	7 830	6 940	4 250	4 520	2 880	3 880	2 500	6.69
	-3.0	*10 310	*10 310	*11 030	7 980	7 010	4 310			4 910	3 140	5.72
	-4.5									*6 100	5 410	3.98

ZAXIS 160LC BLADE (ABOVE GROUND) MONOBLOCK BOOM

Rating over-front Rating over-side or 360 degrees Unit : kg

Conditions	Load point height m	Load radius								At max. reach		
		1.5 m		3.0 m		4.5 m		6.0 m		meter		
Boom 5.10 m	4.5					*4 980	*4 980	*4 600	3 630	4 350	3 200	6.51
Arm 2.22 m	3.0					*6 270	5 280	4 820	3 510	3 840	2 820	6.97
Counterweight	1.5					7 180	4 970	4 670	3 370	3 670	2 680	7.08
3 200 kg	0 (Ground)					7 000	4 810	4 570	3 280	3 780	2 750	6.87
Shoe 500 mm	-1.5			*11 720	8 790	6 970	4 780	4 560	3 270	4 270	3 070	6.30
	-3.0			*10 440	8 970	7 080	4 880			5 630	3 980	5.25
Boom 5.10 m	6.0							*3 300	*3 300	*3 150	*3 150	6.05
Arm 2.58 m	4.5					*4 560	*4 560	*4 290	3 650	*3 080	2 930	6.89
Counterweight	3.0			*8 860	*8 860	*5 870	5 340	4 830	3 520	*3 190	2 610	7.33
3 200 kg	1.5					7 220	5 010	4 670	3 380	3 400	2 490	7.44
Shoe 500 mm	0 (Ground)			*6 270	*6 270	7 000	4 820	4 550	3 270	3 490	2 550	7.23
	-1.5	*5 740	*5 740	*10 420	8 740	6 930	4 760	4 510	3 230	3 880	2 810	6.69
	-3.0	*10 310	*10 310	*11 030	8 890	7 000	4 820			4 910	3 510	5.72
	-4.5									*6 100	6 000	3.98

ZAXIS 160LC BLADE (ON GROUND) MONOBLOCK BOOM

Rating over-front Rating over-side or 360 degrees Unit : kg

Conditions	Load point height m	Load radius								At max. reach		
		1.5 m		3.0 m		4.5 m		6.0 m		meter		
Boom 5.10 m	4.5					*4 980	*4 980	*4 600	3 630	*4 600	3 200	6.51
Arm 2.22 m	3.0					*6 270	5 280	*5 090	3 510	*4 780	2 820	6.97
Counterweight	1.5					*7 540	4 970	*5 680	3 370	*5 020	2 680	7.08
3 200 kg	0 (Ground)					*8 230	4 810	*6 070	3 280	*5 310	2 750	6.87
Shoe 500 mm	-1.5			*11 720	8 790	*8 200	4 780	*6 020	3 270	*5 670	3 070	6.30
	-3.0			*10 440	8 970	*7 290	4 880			*6 070	3 980	5.25
Boom 5.10 m	6.0							*3 300	*3 300	*3 150	*3 150	6.05
Arm 2.58 m	4.5					*4 560	*4 560	*4 290	3 650	*3 080	2 930	6.89
Counterweight	3.0			*8 860	*8 860	*5 870	5 340	*4 840	3 520	*3 190	2 610	7.33
3 200 kg	1.5					*7 260	5 010	*5 500	3 380	*3 460	2 490	7.44
Shoe 500 mm	0 (Ground)			*6 270	*6 270	*8 120	4 820	*5 980	3 270	*3 990	2 550	7.23
	-1.5	*5 740	*5 740	*10 420	8 740	*8 270	4 760	*6 080	3 230	*5 040	2 810	6.69
	-3.0	*10 310	*10 310	*11 030	8 890	*7 620	4 820			*5 740	3 510	5.72
	-4.5									*6 100	6 000	3.98

EQUIPMENT

● : Standard equipment

○ : Optional equipment

ENGINE

Alternator 50 A	●
Air cleaner double filters	●
Auto idle system	●
Auto shut-down control	●
Cartridge-type engine oil filter	●
Cartridge-type fuel main filter	●
Cartridge-type fuel pre-filter	●
Dust-proof indoor net	●
Dry-type air filter with evacuator valve (with air filter restriction indicator)	●
ECO/PWR mode control	●
Electrical fuel feed pump	●
Engine oil drain coupler	●
Engine warm-up device	●
Fan guard	●
Fuel cooler	●
High performance water separator	●
Isolation-mounted engine	●
Maintenance free pre-cleaner	●
Muffler filter	●
Radiator, oil cooler and intercooler	●
Radiator reserve tank	●

HYDRAULIC SYSTEM

Auto power lift	●
Control valve with main relief valve	●
Extra port for control valve	●
Full-flow filter	●
High mesh full flow filter with restriction indicator	○
Hose rupture valve	●
Pilot filter	●
Power boost	●
Suction filter	●
Swing dampener valve	●
Variable relief valve for breaker & crusher	●
Work mode selector	●

CAB

All-weather sound suppressed steel cab	●
AM-FM radio	●
Ashtray	●
Auto control air conditioner	●
Auxiliary function lever (breaker or assist)	○
AUX. terminal and storage	●
Cigarette lighter 24 V	●
CRES V (center pillar reinforced structure) cab	●
Drink holder with hot & cool function	●
Electric double horn	●
Engine shut-off switch	●
Equipped with reinforced, tinted (green colour) glass windows	●
Evacuation hammer	●
Fire extinguisher bracket	○
Floor mat	●
Footrest	●
Front guard (lower mesh type)	○
Front guard (upper mesh type)	○
Front window washer	●
Glove compartment	●
Hot & cool box	●
Intermittent windshield wipers	●
Key cylinder light	●
Laminated round glass window	●
LED room light with door courtesy	●
Mesh guard (cab top)	○
OPG front guard Level II (ISO10262) compliant cab	○
OPG top guard Level II (ISO10262) compliant cab	○
Pilot control shut-off lever	●
Power outlet 12 V	●
Rear tray	●
Retractable seat belt	●
ROPS (ISO12117-2) compliant cab	●
Rubber radio antenna	●
Seat adjustment part : backrest, armrest, height and angle, slide forward / back	●
Seat : air suspension seat with heater	●
Short wrist control levers	●
Sun visor (front window/side window)	○
Transparent roof with slide curtain	●
Windows on front, upper, lower and left side can be opened	●
2 speakers	●
4 fluid-filled elastic mounts	●

MONITOR SYSTEM

Alarm buzzers: overheat, engine oil pressure, overload	●
Alarms: overheat, engine warning, engine oil pressure, alternator, minimum fuel level, hydraulic filter restriction, air filter restriction, work mode, overload, etc	●
Display of meters: water temperature, hour, fuel rate, clock	●
Other displays: work mode, auto-idle, glow, rearview monitor, operating conditions, etc	●
32 languages selection	●

LIGHTS

Additional boom light with cover	○
Additional cab roof front 2 lights	●
Additional cab roof rear 1 light	●
2 working lights	●

UPPER STRUCTURE

Batteries 2 x 74 Ah	●
Counterweight 3 200 kg	●
Electric fuel refilling pump with auto stop and filter	○
Fuel level float	●
Hydraulic oil level gauge	●
Rear view camera	●
Rear view mirror (right & left side)	●
Swing parking brake	●
Tool box	●
Undercover	●
Undercover 6.0 mm reinforced	○
Utility space	●

UNDERCARRIAGE

Bolt-on sprocket	●
Reinforced track links with pin seals	●
Shoe : 500 mm triple grouser	●
Travel motor covers	●
Travel parking brake	●
Track undercover	●
Upper and lower rollers	●
1 track guards (each side) and hydraulic track adjuster	●
4 tie down brackets	●

FRONT ATTACHMENTS

Arm (lower reinforced)	●
Casted bucket link A	●
Centralized lubrication system	●
Dirt seal on all bucket pins	●
Flanged pin	●
HN bushing	●
Reinforced link B	○
Reinforced resin thrust plate	●
WC (tungsten-carbide) thermal spraying	●
Welded bucket link A with welded hook	○

ATTACHMENTS

Accessories for 2 speed selector	○
Additional pump (30 L/min)	○
Assist piping	○
Attachment basic piping	●
Breaker and crusher piping	●
Pilot accumulator	●

MISCELLANEOUS

Battery disconnect switch	●
Global e-Service	●
Level indicator	●
Lockable fuel refilling cap	●
Lockable machine covers	●
Onboard information controller	●
Satellite communication system unit	●
Skid-resistant tapes, plates and handrails	●
Standard tool kit	●
Swing alarm	○
Travel alarm	●
Travel direction mark on track frame	●

Standard and optional equipment may vary by country, so please consult your Hitachi dealer for details.

