

↗ DOMETIC

AIR CONDITIONER

COOLAIR

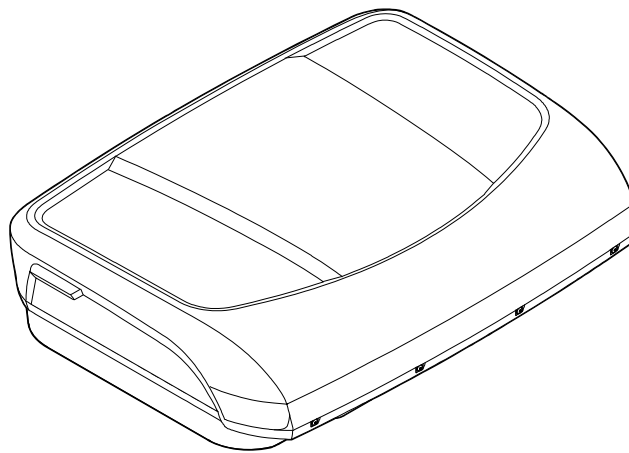

RTX 1000 and RTX 2000

EN	Parking Cooler Installation and Operation Manual	2
FR	Climatiseur de stationnement Manuel d'installation et d'utilisation	24
ES	Equipo de aire acondicionado a motor parado Manual de instalación y uso	46

 WARNING
Cancer and Reproductive Harm www.P65Warnings.ca.gov



Service Center & Dealer Locations

Visit: www.dometic.com

Read these instructions carefully. These instructions **MUST** stay with this product.

Contents

1 Explanation of Symbols and Safety Instructions 2

1.1 Recognize Safety Information 2

1.2 Understand Signal Words 3

1.3 Supplemental Directives 3

1.4 General Safety Messages 3

2 Intended Use 3

3 General Information 4

3.1 Tools and Materials 4

3.2 Model Identification 5

3.3 Component Locations 5

3.4 External Dimensions 6

3.5 Internal Dimensions 6

3.6 Unit Placement Requirements 6

4 Specifications 7

4.1 Product Specifications 7

5 Wiring Diagram 8

6 Pre-Installation 9

6.1 Preparing the Roof Opening 9

6.2 Preparing the Unit 10

6.3 Attaching the Seal to the Roof Opening . . . 10

7 Installation 11

7.1 Positioning the Unit on the Roof 11

7.2 Securing the Unit to the Mounting Brackets 11

7.3 Routing the Wiring 12

7.4 Installing the Cover 13

8 Configuring the System Software 13

8.1 Entering and Exiting Configuration Mode 13

8.2 Setting the Low Voltage Shut-Down Voltage - P.01 13

8.3 Setting the Unit For Temperature Display - P.02 14

9 Operation 14

9.1 Understanding the Controls 14

9.2 Available Menus 17

9.3 Menu Mode 17

10 Using the Parking Cooler 17

10.1 Turning the Parking Cooler On 18

10.2 Switching the Parking Cooler to Standby Mode 18

10.3 Turning the Parking Cooler Off 18

10.4 Using Menus 18

10.5 Using the Air Conditioner 19

10.6 Setting the Temperature 19

10.7 Setting the Mode 19

10.8 Setting the Timer 20

11 Display Messages 20

11.1 Control Panel Warnings 20

11.2 Control Panel Fault Messages 21

12 System Specifications 22

13 Cleaning and Maintenance 22

14 Disposal 23

Limited One-Year Warranty 23

1 Explanation of Symbols and Safety Instructions

This manual has safety information and instructions to help you eliminate or reduce the risk of accidents and injuries.

1.1 Recognize Safety Information

 **This is the safety alert symbol.** It is used to alert you to potential physical injury hazards. Obey all safety messages that follow this symbol to avoid possible injury or death.

1.2 Understand Signal Words

A signal word will identify safety messages and property damage messages, and also will indicate the degree or level of hazard seriousness.

DANGER!

Indicates a hazardous situation that, if **not** avoided, will result in death or serious injury.

WARNING

Indicates a hazardous situation that, if **not** avoided, could result in death or serious injury.

CAUTION

Indicates a hazardous situation that, if **not** avoided, could result in minor or moderate injury.

NOTICE: Used to address practices **not** related to physical injury.

 Indicates additional information that is **not** related to physical injury.

1.3 Supplemental Directives

To reduce the risk of accidents and injuries, please observe the following directives before proceeding to install or operate this unit:

- Read and follow all safety information and instructions.
- Read and understand these instructions before installing or operating this product.
- The unit shall be installed in accordance with national wiring regulations.
- For an all-pole disconnection device that has at least 0.12 in. (3 mm) clearances in all poles and has a leakage current that may exceed 10 mA, the residual current device (RCD) with a rated residual operating current not exceeding 30 mA and disconnection must be incorporated in the fixed wiring in accordance with the wiring rules.

- The installation must comply with all applicable local or national codes.

1.4 General Safety Messages

WARNING: ELECTRICAL SHOCK, FIRE, AND/OR EXPLOSION HAZARD. Failure to obey the following warnings could result in death or serious injury:

- Use only Dometic replacement parts and components that are specifically approved for use with the unit.
- Avoid improper installation, adjustment, alterations, service, or maintenance of the unit. Service and maintenance **must** be done by a qualified service person only.
- Do **not** modify this product in any way. Modification can be extremely hazardous.
- This unit is **not** intended for use by persons (including children) with reduced physical, sensory or mental capabilities, or lack of experience and knowledge, unless they have been given supervision or instruction concerning the use of the unit by a person responsible for their safety.
- Children should be supervised to ensure that they do **not** play with the unit.
- If the supply lead is damaged, it **must** be replaced by the manufacturer, its service agent, or similarly qualified persons in order to avoid a hazard.
- Use care when diagnosing and/or adjusting components on a powered unit.

2 Intended Use

The parking cooler (also referred to as the “product” or “unit”) is used to supply the interior of the driver’s cab with cool and dehumidified air. The system is designed for stationary use or can be used while driving. The parking cooler is not suitable for use in agricultural or construction vehicles. The parking cooler is suitable for ambient temperatures of 41 °F to 126 °F (5 °C to 52 °C).

Dometic accepts no liability for damage in the following cases:

- Faulty assembly or connection
- Damage to the product resulting from mechanical influences and excess voltage
- Alterations to the product without express permission from Dometic
- Use for purposes other than those described in the operating manual

Dometic Corporation reserves the right to modify appearances and specifications without notice.

3 General Information

This section provides information regarding the tools and materials, component locations, model identification, external and internal dimensions, and unit placement.

 The images used in this document are for reference purposes only. Components and component locations may vary according to specific product models. Measurements may vary ± 0.38 in. (10 mm).

3.1 Tools and Materials

Dometic recommends that the following tools and materials be used:

Included Parts	Quantity
Cover Frame Universal CoolAir 3rd Generation	1
Seal 0.4 in. x 0.8 in. (10 mm x 20 mm)	1 x 2.7 mm
Support Bracket	2
Hex Bolt M8 x 100	4
Threaded Insert With Flange M8	4
Threaded Insert With Flange M6	4
Washer 8.5 x 20 x 1.25	4
Spring Washer M8	4
Nut M8	4
Allen Screw With Cylinder Head M6 x 110	4
Spacer 6.2 x 10 x 48	8

Included Parts	Quantity
Washer M6	4
Power Cable External Short RTX 12V	1
Cable Ties	1
1/4 in. Hex Bit	1
80 A Fuse	1
200 A Fuse Holder	1
2 A Fuse	1
Cable Terminals for Battery Cable AWG 4 3/8 in.	2
Cable Terminal for Fuse Holder 1/4 in.	2
Ring Terminal 0.02 in. (0.5 mm)	2
Joint Connector 0.02 in. (0.5 mm)	1
2 A Fuse Holder	1
Loom Tubing 9.8 ft (3 m)	1
Opening Template 18.9 in. x 15.3 in. (480 mm x 390 mm)	1
Seal 35 x 20 x 3000	1

Recommended Tools

Angle Grinder	Impact Gun
Cutting Disc for Metal	Screwdriver Bit Set
Extension Cord	Hole Saw Set
Drill	Self Tapping Screws
Automotive Staple Remover	Flat Head Screwdriver
Phillips Screwdriver	Pliers
Side Cutters	

3.2 Model Identification

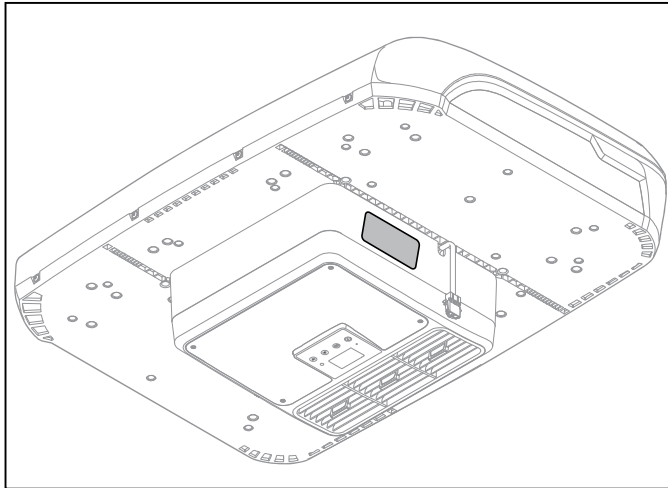

1 Data Plate Location

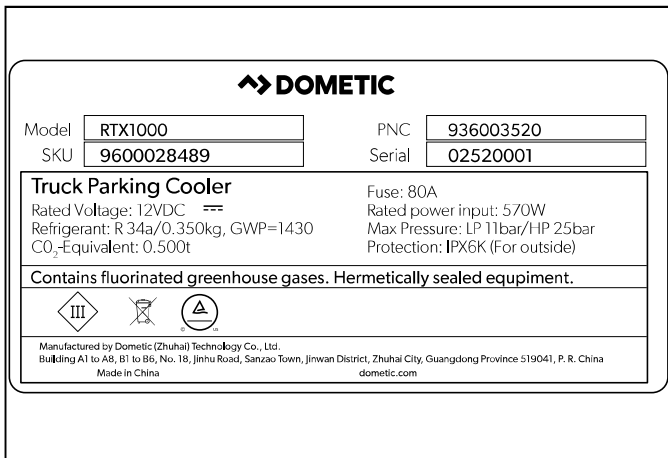

2 Data Plate RTX 1000

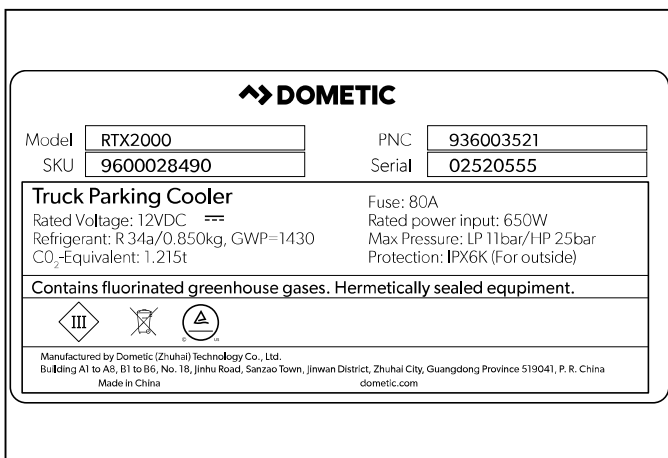

3 Data Plate RTX 2000

3.3 Component Locations

This section identifies the unit's main components.

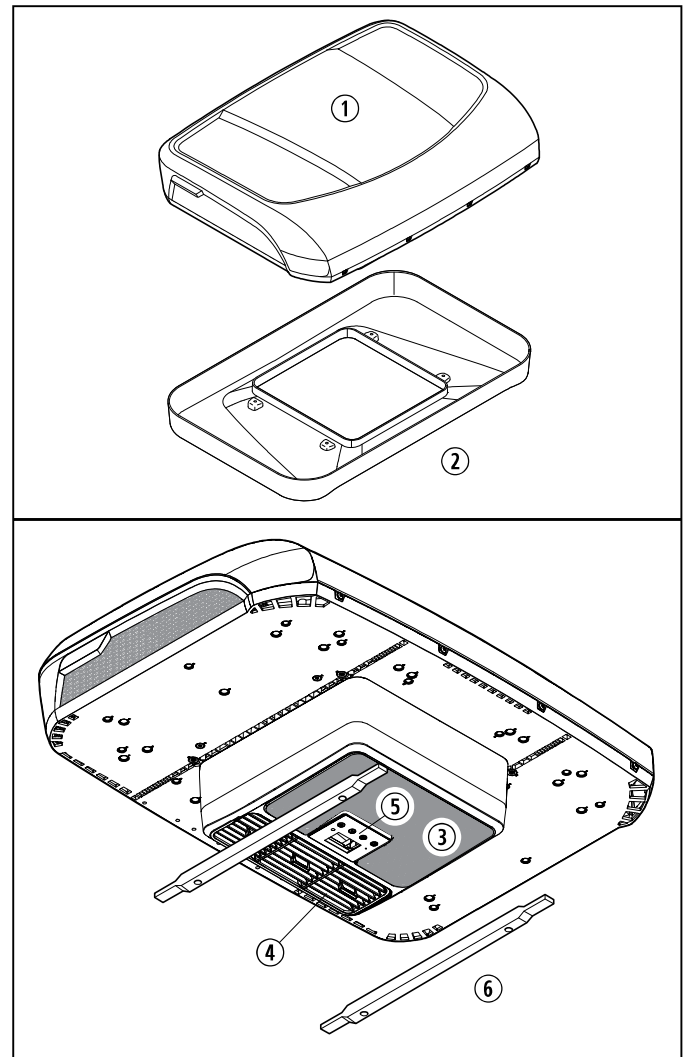

4 RTX Component Locations

- ① External Cover
- ② Cover Frame
- ③ Intake Grille
- ④ Blower Nozzle
- ⑤ Control Panel
- ⑥ Mounting Bracket

3.4 External Dimensions

This section provides the external dimensions of the unit.

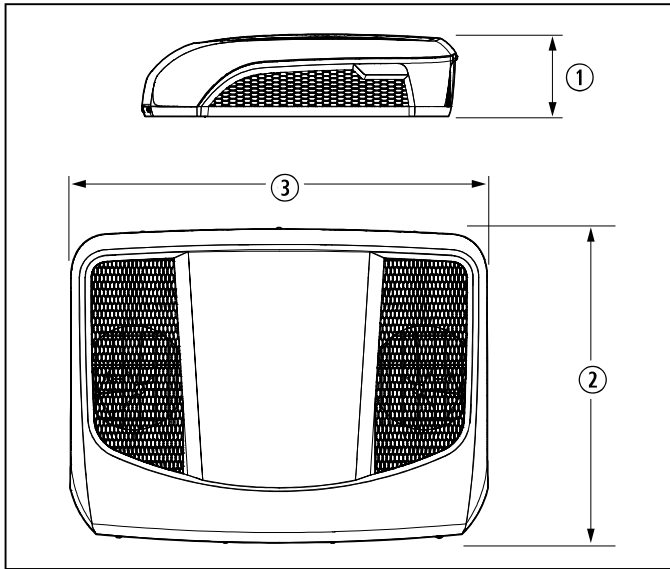

5 RTX External Dimensions

① Height	② Length	③ Width
6.6 in. (169 mm)	25.4 in. (645 mm)	33.9 in. (860 mm)

3.5 Internal Dimensions

This section provides the internal dimensions of the unit.

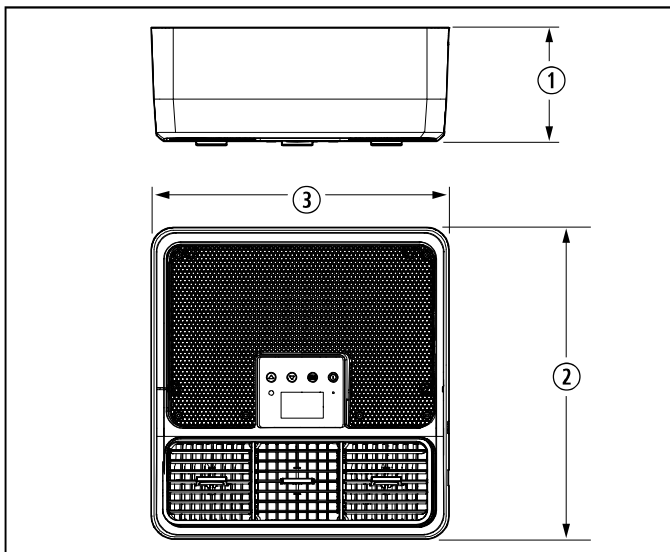

6 RTX Internal Dimensions

① Height	② Length	③ Width
5 in. (127 mm)	15 in. (381 mm)	14 in. (356 mm)

3.6 Unit Placement Requirements

The RTX is specifically designed for installation on the roof of a vehicle. To determine where to place the unit, consider the following items:

- A 18.9 in. x 15.3 in. (480 mm x 390 mm) opening, hereinafter referred to as "roof opening", is required. The roof opening is part of the return air system of the unit.
- The joist support frames must be spaced no greater than 16 in. (406 mm) on center. The unit is designed to fit over an existing roof vent opening or a new roof opening created by the installer.
- When no roof vent is available or when another location is desired, an opening must be cut through the roof and ceiling of the vehicle. This opening must be located between the roof reinforcement beams.
- Mount the unit slightly forward of the vehicles center (front to back) and centered from side to side.

3.6.1 Tilt Requirements

When measuring for placement, consider the following tilt requirements:

1. Make all measurements while the vehicle is parked on a level surface.
2. Install the unit on a flat and level roof section.
3. Use the tilt allowance table to determine the maximum acceptable roof tilt.

Tilt Allowance	
Model Number	Maximum Allowance (in all directions)
RTX 1000	8°
RTX 2000	20°

3.6.2 Air Flow Requirements

This section identifies the areas that should remain free from obstruction to allow for proper air flow to the unit.

- i** Check inside the vehicle for obstructions, such as door openings, room dividers, curtains, and ceiling fixtures.

i When considering the unit's placement, avoid any structures that would obstruct air flow to the unit. Restricted air flow will affect the unit's performance.

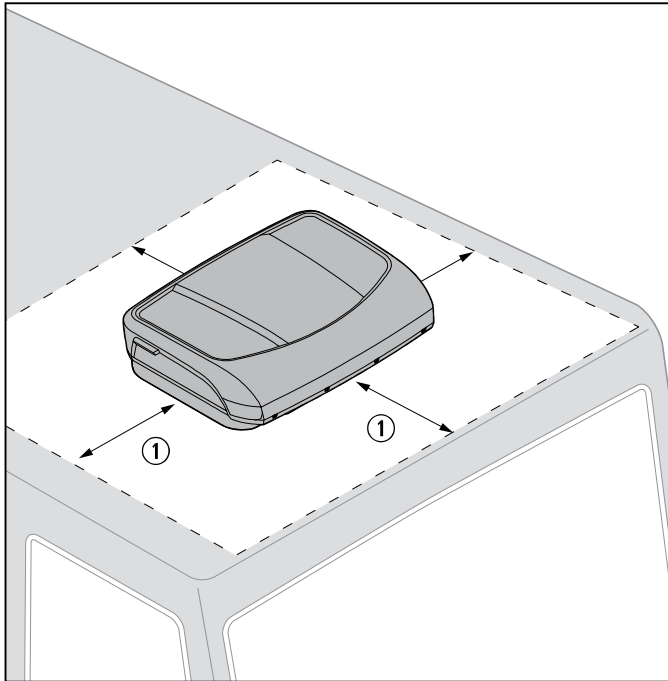

7 Clearance Requirements

① 12 in.–20 in. (305 mm–508 mm)

The ventilation openings must not be covered. A minimum distance of 3.8 in. (98 mm) must be maintained from other external attachments.

4 Specifications

This section provides the product specifications and the electrical specifications for the RTX 1000 and the RTX 2000.

4.1 Product Specifications

Weight	RTX 1000: 52.8 lbs (24 kg)
	RTX 2000: 72.6 lbs (33 kg)
Battery Capacity	180 Ah or greater
Roof Thickness With a 0.39 in. x 0.78 in. (10 mm x 20 mm) Seal	1.9 in.–3.3 in. (49 mm–84 mm)
Roof Thickness With a 1.3 in. x 0.78 in. (35 mm x 20 mm) Seal	1.1 in.–2.4 in. (28 mm–61 mm)
Input Voltage	10 VDC–15 VDC
Overall Height When installed	Not to exceed 13.1 ft (4 m)

5 Wiring Diagram

This section provides the wiring diagram for the RTX 1000 and the RTX 2000 models.

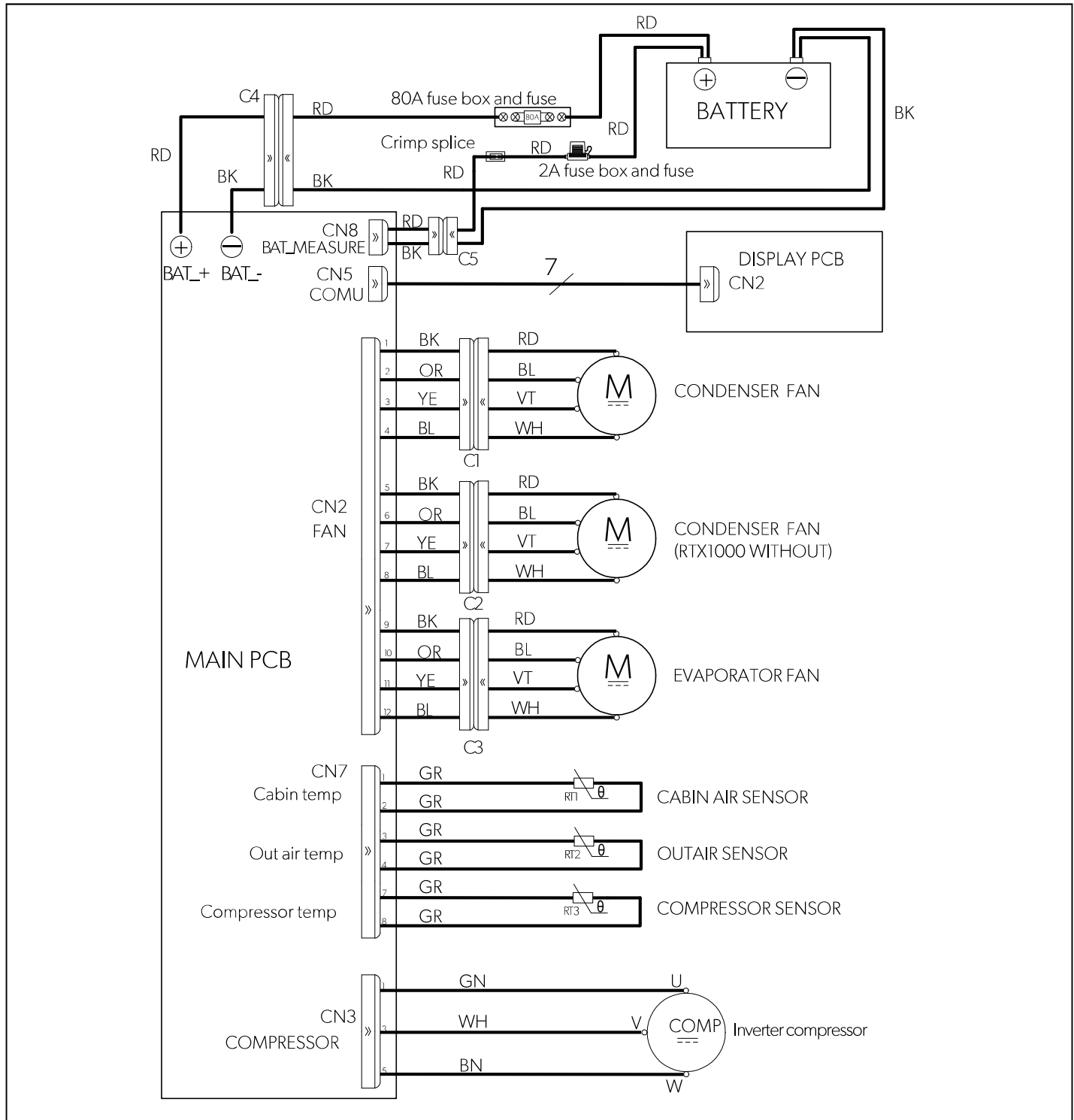

8 RTX Wiring Diagram

6 Pre-Installation

Before installation, check with the vehicle manufacturer to ensure that the vehicle body is designed for the static weight of the parking cooler and the dynamic loads created when the vehicle is in motion. Dometic accepts no liability whatsoever in that regard.

The external cover of the parking cooler can be painted. Dometic recommends that the painting be done by a professional paint shop.

6.1 Preparing the Roof Opening

There are two options for preparing the roof opening. Refer to “Creating a New Roof Opening” on page 9, if you must create a new roof opening or refer to “Using an Existing Roof Opening” on page 9, if you are using an existing roof opening.

6.1.1 Creating a New Roof Opening

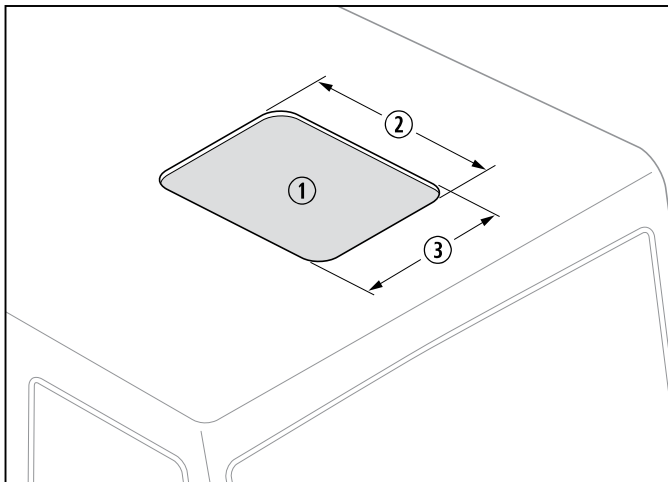

9 Roof Opening Dimensions

- ① Roof Opening
- ② 18.9 in. (480 mm)
- ③ 15.3 in. (390 mm)

1. Check the dimensions of the system to be installed.
2. Drill a 1/4 in. (6 mm) hole in the center of the vehicle’s roof.

i To simplify the task of creating the opening, there is a template integrated in the packaging of the installation kit.

3. Center the cutting template on the 1/4 in. (6 mm) hole to ensure the unit will not interfere with any lamps or accessories inside of the vehicle.
4. Use a 2 in. (51 mm) hole saw to drill holes into the vehicles roof on each of the four corners of the cutting template. This creates rounded edges when the cutting is complete.
5. Use an angle grinder to cut the remaining vehicle roof area around the cutting template.

6.1.2 Using an Existing Roof Opening

1. Remove the hardware securing the roof vent to the roof of the vehicle.

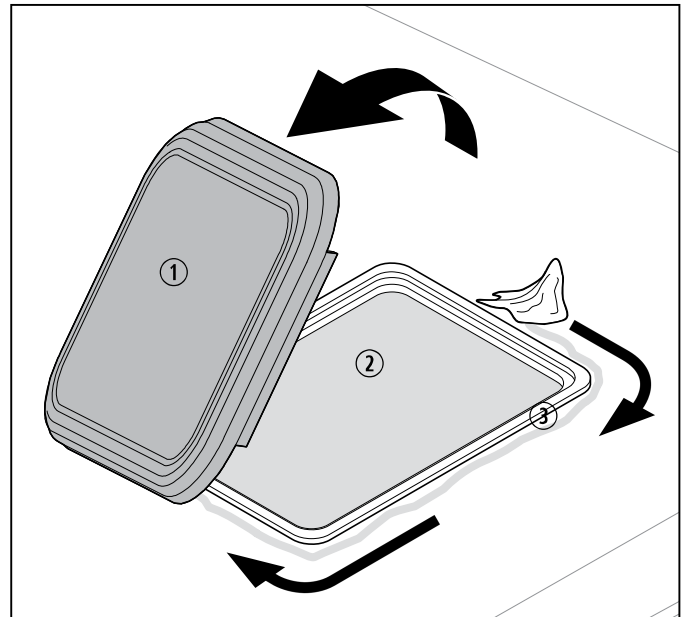

10 Preparing the Existing Opening

- ① Roof Vent
- ② Opening
- ③ Residual Sealant

2. Pull the roof vent away from the roof of the vehicle.
3. Remove any residual sealant and grease from around the roof opening.
 - i** Dispose of all waste material, glue, silicon and seals separately. When doing so, follow the waste disposal requirements applicable in your local area.
4. Measure the existing eight hardware hole diameters.
5. If necessary, drill the hardware holes to a diameter of 0.33 in. (8.5 mm).

- If more space is required between the unit and the roof of the vehicle, use a 1.37 in. x 0.78 in. (35 mm x 20 mm).
4. Apply a flexible, non-hardening butyl sealant to the area between where the ends of the seal join and the top edge of the seal.

7 Installation

⚠ WARNING: ELECTRICAL SHOCK HAZARD.
Failure to follow these warnings could result in death or serious injury.

- Before carrying out any work on electrically operated components, make sure that they are disconnected from the power supply.
- Before installing the parking cooler, disconnect all connections to the vehicle battery.
- All electrical connections **must** be made by a trained technician.

⚠ CAUTION: PERSONAL INJURY HAZARD.

Incorrect installation of the parking cooler may place the safety of the user at risk. Failure to obey this caution could result in minor or moderate injury.

NOTICE: The parking cooler may only be installed by a qualified technician.

NOTICE: The connection to the vehicle's electrical system should be protected by a 80 A fuse for the power supply and a 2 A fuse for the voltage monitor.

NOTICE: The battery **must** be capable of supplying the required current and voltage.

Refer to the sections below to position and install the unit onto the roof of the vehicle.

7.1 Positioning the Unit on the Roof

1. Remove the unit from the carton and discard the carton.
2. Move the unit to the roof.

i Do not slide the unit along a surface. Otherwise, damage to the gasket on the bottom of the unit could occur and cause a leak.

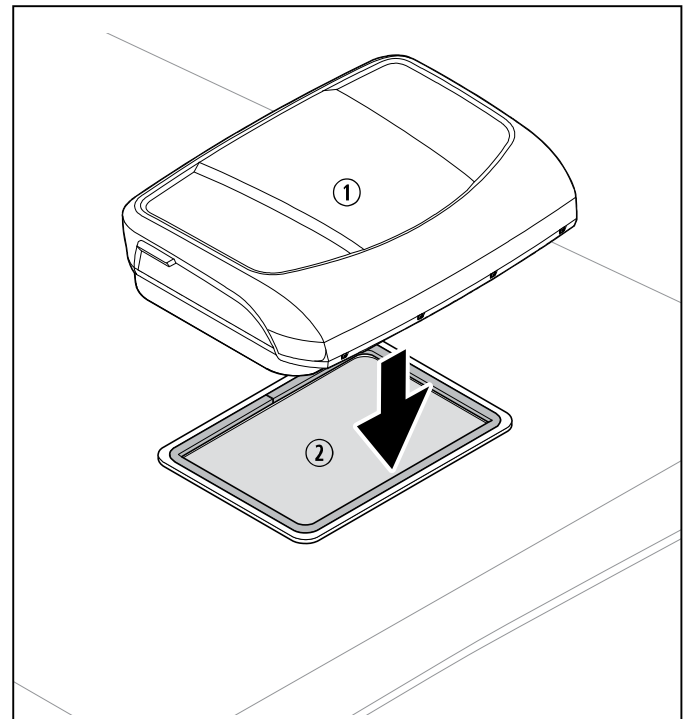

14 Positioning the Unit

- ① RTX Unit ② Opening

3. Lift and place the unit over the prepared roof opening.

i Once the unit is in position on the roof of the vehicle, the seal should make contact all the way around the underside of the unit.

7.2 Securing the Unit to the Mounting Brackets

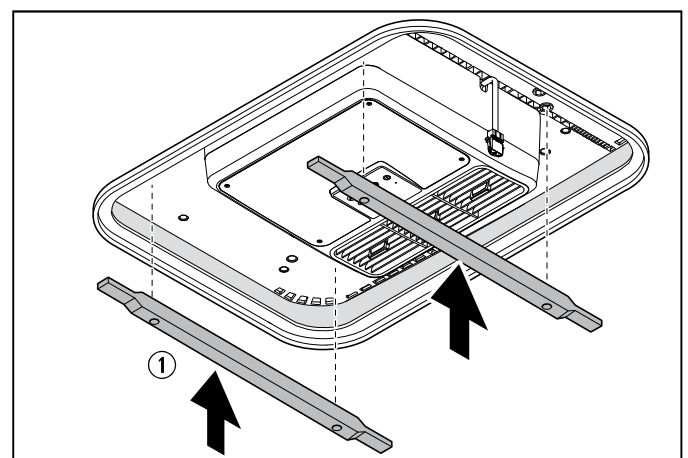

15 Positioning the Mounting Brackets

- ① Mounting Bracket

- From the inside of the cab, position the mounting brackets so they are within the roof opening and are spaced 16 in. (406 mm) apart.

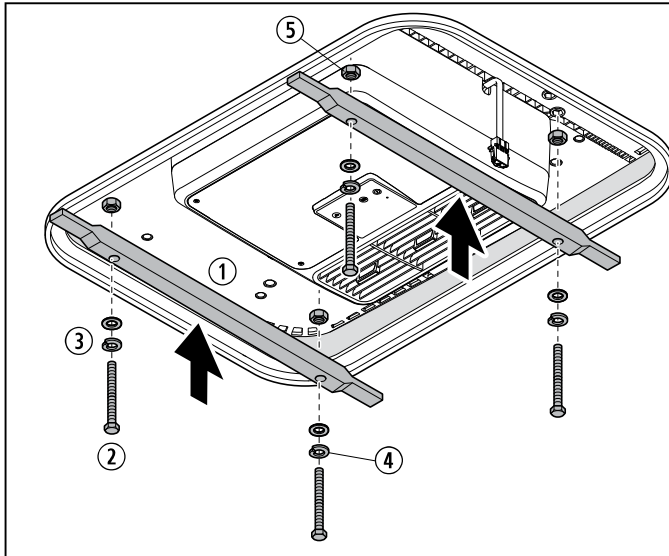

16 Securing the Mounting Bracket

- | | |
|--------------------|------------------------|
| ① Mounting Bracket | ④ 8.5 x 20 Lock Washer |
| ② M8 x 100 Screw | |
| ③ M8 Washer | ⑤ M8 Nut |

- Insert the four M8 x 100 screws, M8 washers, and 8.5 x 20 lock washers into the mounting brackets.
- Screw the four M8 nuts onto the four M8 x 100 screws protruding from the top of the mounting brackets.
- Torque the four M8 x 100 screws to 44 in. lbs (5 N·m).

7.3 Routing the Wiring

- Connect the unit directly to the main power distribution box.
- i** Ask your vehicle manufacturer for the specifications of the main power distribution box.

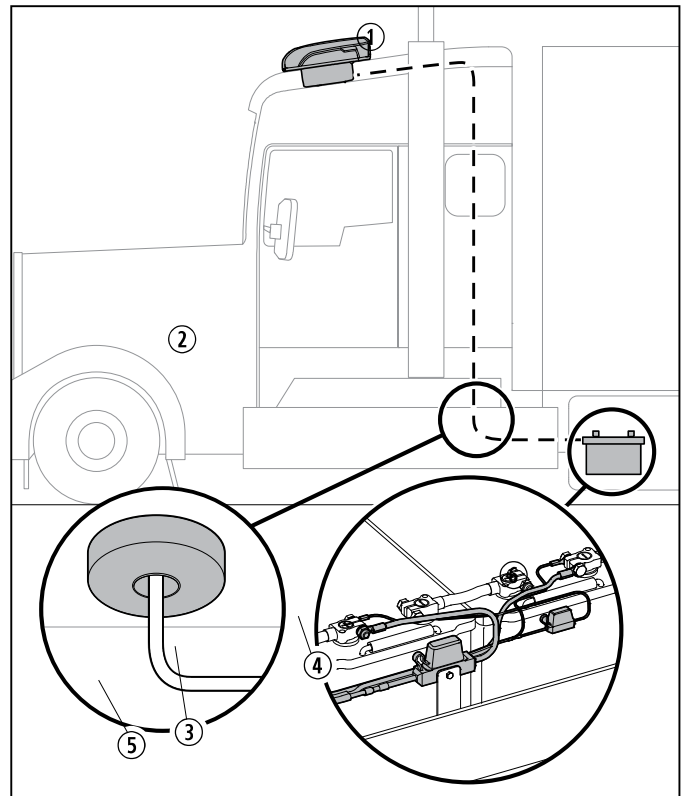

17 Routing the Power Supply Lead

- | | |
|------------------|------------------------|
| ① Unit | ④ Blade Fuse 2 A |
| ② Power Supply | ⑤ Joint Connector |
| ③ Maxi Fuse 80 A | ⑥ 2 in. Wiring Grommet |

- Use a hole saw to drill a 2 in. (51 mm) hole in the floor of the vehicle.
- Install a 2 in. (51 mm) grommet into the hole that was drilled in the floor of the vehicle.
- Route the cables through the lining of the vehicle to the floor of the vehicle (Fig. 17).
- Connect the red positive lead for the power supply via an 80 A fuse.
- Connect the red positive lead for the voltage signal via a 2 A fuse.

7.4 Installing the Cover

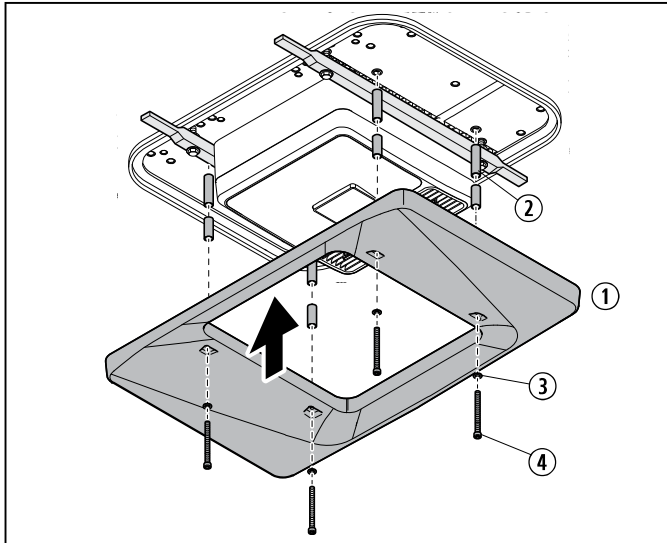

18 Installing the Cover

- ① Cover
- ② 10 x 48 Spacer
- ③ M6 Washer
- ④ M6 x 100 Screw

1. From inside the vehicle, place the eight 10 x 48 spacers into the four cover mounting locations.
2. Place the cover over the mounting brackets and the roof opening.
3. Insert the four M6 x 100 screws and the four M6 washers into the four mounting locations in the cover and tighten the screws. The maximum allowable torque for M6 x 100 screw is 35 in. lbs (4 Nm).

i The cover should be flush with the roof of the vehicle when installed.

8 Configuring the System Software

Before the system is first operated, the system settings can be adjusted to suit the various installation conditions. These adjustments must be made by the installer.

Display	Indication Parameter	Meaning	Factory Setting
P.01	Low voltage Shut-Down	The battery monitor shuts Down the system at the factory setting voltage.	11.4 V
P.02	Unit for temperature display	The temperature can be displayed in °C or °F.	°F

i Configuration mode can still be activated if the low voltage cut-out has switched off the system and only the residual voltage is available.

8.1 Entering and Exiting Configuration Mode

1. Refer to “Understanding the Controls” on page 14 for a list of buttons and button functions.
2. Press and hold the **List** button.
3. Press and hold the **On/Off** button for longer than three seconds.
4. The parking cooler switches to CONFIGURATION mode. The display shows “P.01” and the battery symbol flashes.
5. Press the **Up** or **Down** button to scroll through the menu to select the desired menu item.
6. Press the **List** button to open the desired menu item.
7. Press and hold the **On/Off** button for longer than three seconds to exit CONFIGURATION mode.

8.2 Setting the Low Voltage Shut-Down Voltage - P.01

The battery monitor protects the battery against discharging excessively.

NOTICE: If the unit is switched off by the battery monitor, it means the battery charge level is low. Avoid repeatedly starting or using the electrical equipment. Make sure that the battery is recharged. As soon as the required voltage is available, the system can be operated again.

If only the power supply voltage is available to the parking cooler, the system switches off.

1. Enter configuration mode. Refer to “Entering and Exiting Configuration Mode” on page 13. The display shows “P.01” and the battery symbol flashes.
2. Press the **List** button to change the setting. The current setting displays.
3. Use the **Up** or **Down** button to select the voltage level for low voltage shutdown. The low voltage shutdown setting can be adjusted in 0.1 V increments from 10 V to 12.5 V.

i The level for the low voltage shut-down should not be set any lower than the minimum battery voltage required to be able to start the engine under any conditions. As a rule that should be no less than 11 V.

4. Press the **List** button to save the setting. The set value is saved and then applied when the system is restarted. The menu appears and you can select another menu item by pressing the **Up** or **Down** button.

8.3 Setting the Unit For Temperature Display - P.02

The system can display the room temperature in °C or °F. This parameter can be configured by performing the following:

1. Enter configuration mode. Refer to “Entering and Exiting Configuration Mode” on page 13. The display shows “P.01” and the symbol flashes.
2. Press the **Up** or **Down** button to select the menu item P.02. The display shows “P.02” and the symbol is illuminated.

3. Press the **List** button to change the setting. The code for the current setting is displayed:

- 0 = °C
- 1 = °F

4. Press the **Up** or **Down** button to select the desired temperature unit.

5. Press the **List** button to save the setting. The set value is saved and then applied when the system is restarted. The menu appears and you can select another menu item by pressing the **Up** or **Down** buttons.

9 Operation

This section describes the RTX 1000’s and the RTX 2000’s operating controls and settings.

9.1 Understanding the Controls

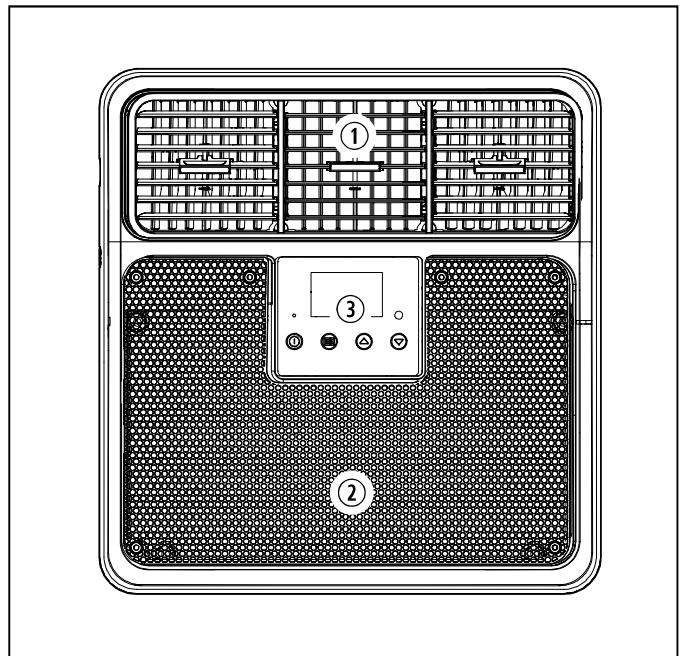

19 Device Elements

- ① Blower Nozzles
- ② Intake Grill
- ③ Control Panel

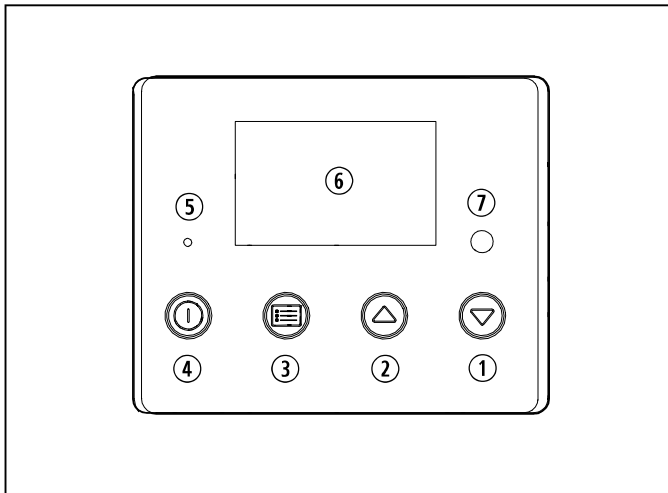

20 Control Panel

Ref.	Description	Function
①	Down Button	Scrolls through the menu items.
②	Up Button	Scrolls through the menu items.
③	List Button	Opens the settings sub-menus or confirm the value of the selected parameter.
④	On/Off Button	Switches the parking cooler: <ul style="list-style-type: none"> • On • Off (press button for at least 3 seconds) • To standby mode (press button briefly)
⑤	LED Power (Blue)	Only lights up when the system is switched on or in standby.
⑥	Display	Displays all unit information.
⑦	Infrared Receiver	Receives the signal from the remote control.

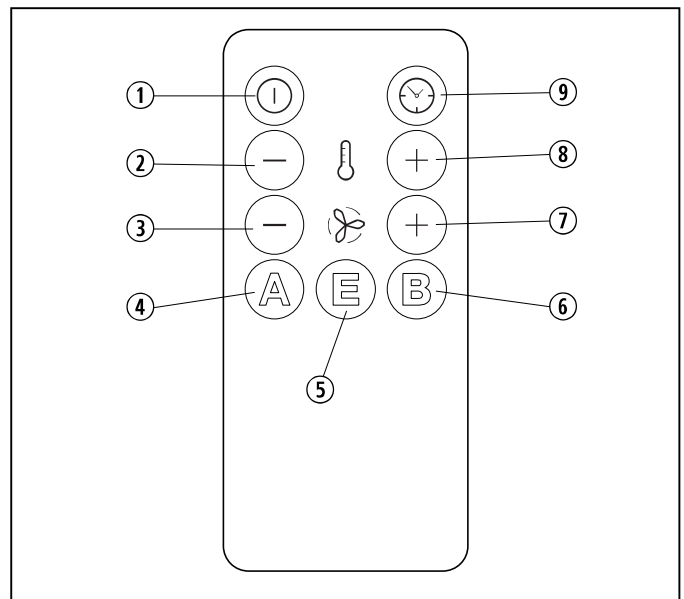

21 Remote Control



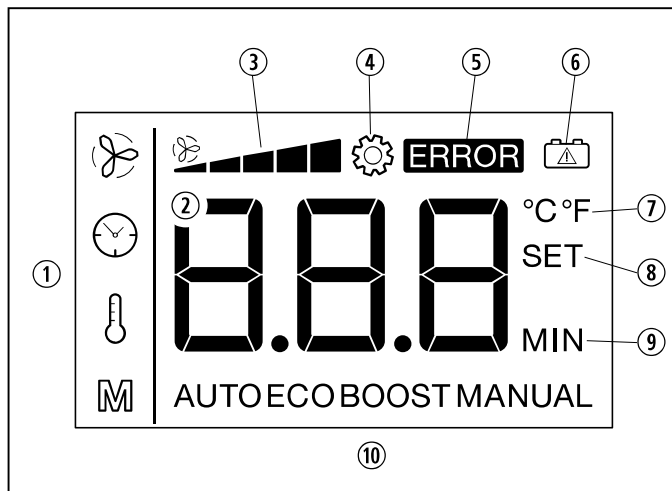

Ref.	Description	Function
①	On/Off Button	Press this button briefly to switch the parking cooler to standby mode or on again, if it is in standby mode. The parking cooler can only be switched on at the control panel.
②	Decrease Temperature Button	Reduces the set point by 1 °C/2 °F.
③	Decrease Fan Speed Button	Switches the parking cooler to MANUAL mode and reduces the speed of the fan.
④	A Button	Switches the parking cooler to AUTO mode.
⑤	E Button	Switches the parking cooler to ECO mode.
⑥	B Button	Switches the parking cooler to BOOST mode.
⑦	Increase Fan Speed Button	Switches the parking cooler to MANUAL mode and increases the speed of the fan.
⑧	Increase Temperature Button	Increases the set point by 1 °C/2 °F.
⑨	Clock Button	Increases the timer running time by 10 minutes.



22 Display

Ref.	Description	Function
①	Mode Panel	The symbol shows the current menu selected.
②	Display Panel	Depending on the current menu, shows: <ul style="list-style-type: none"> • The required temperature • The current fan speed • The remaining running time of the timer
③	Fan Speed Display	Shows the current fan speed.
④	Setting	Lights up when the setting menu has been activated.
⑤	Error	Lights up when the supply voltage falls below a set value. Additionally, the display flashes.
⑥	Battery	Indicates a problem with the supply voltage.
⑦	Degree Setting Display	°C: Lights Up when the temperature is shown in °C. °F: Lights Up when the temperature is shown in °F.
⑧	Temperature Display	Indicates that the set temperature is being shown.
⑨	Min	Lights up when the timer has been set.
⑩	Mode Display	Shows the current mode.

9.2 Available Menus

Menu	Description	Change in Value
	Sets the temperature from 62 °F to 86 °F (17 °C to 30 °C).	2 °F or 1 °C
	Sets the mode.	—
	MANUAL mode: Set the fan speed manually (level 1–5).	1
	Sets the running time of the timer (10–600 minutes).	10 minutes

9.3 Menu Mode



In menu mode, you can select the following sub-menus:

Sub-Menu	Purpose
AUTO	AUTO mode: The fan and the compressor are controlled automatically.
ECO	ENERGY-SAVING mode: The fan and the compressor are controlled automatically. The speed of the compressor is limited electronically.
BOOST	BOOST mode: The system runs at full-power. The system switches to automatic mode after 20 minutes or once the set temperature has been reached.
MANUAL	MANUAL mode: You can set the fan speed manually. The compressor is controlled automatically.

10 Using the Parking Cooler

NOTICE: Do **not** insert foreign objects into the system.

NOTICE: Never close all of the air nozzles of the parking cooler simultaneously. The system will form ice inside.

-  The first time the parking cooler is used, there may be a slight smell. This odor ends after the system has been operating for a short time.
-  In some vehicles, the parking cooler can be shut off via a battery master switch in case of emergency. Check with the vehicle manufacturer.

 The CoolAir parking coolers are designed as air conditioners that can be used while driving however they do not replace the engine-powered vehicle air conditioning system.

Always observe the following:

- If you would like the parking cooler to match the color of your vehicle, only paint the Upper casing of the parking cooler. Only paint the Upper casing when it has been removed. Use light colors when possible.
- Wash your vehicle regularly, as dirty vehicle cabs heat up more quickly.
- Make sure the performance of the parking cooler is not affected by other sources of heat such as heat from cold machines.

It is recommended that you:

- Park your vehicle in the shade when possible.
- If you do not have a vehicle air conditioning system, air out your vehicle well before using the parking cooler. You should always cool Down the vehicle interior before a rest period using the vehicle air conditioning system.
- Keep doors and windows closed.
- Avoid any heat sources in the vehicle.
- Reduce the power consumed by other products to ensure the maximum possible operating time of the parking cooler.
- Select a suitable temperature and operating mode.
- Make sure the blower nozzles and intake grille are not covered by cloths, paper, or other objects.
- The best cooling capacity is achieved when the blower nozzles are not directed towards the intake grille.

10.1 Turning the Parking Cooler On

With the system switched off, press the **On/Off** button. The following occurs upon system startup:

- The fan starts.
- The Power LED illuminates.
- The digital display shows the current status of the parking cooler.

i Depending on the system status, the system compressor is switched on with a delay of up to 180 seconds.

10.2 Switching the Parking Cooler to Standby Mode

Briefly press the **On/Off** button to switch the parking cooler to standby mode. The following occurs upon switching to standby mode:

- The parking cooler saves the current settings.
- The power LED continues to stay illuminated.

i When the parking cooler is in BOOST mode and switched to standby mode, it will start the next time in AUTO mode. A running timer is set to 0 by switching the parking cooler in standby mode. The parking cooler switches completely off after 12 hours in standby mode to save power.

10.3 Turning the Parking Cooler Off

Press the **On/Off** button for at least 3 seconds to switch off the parking cooler. The following occurs upon system shutdown.

- The parking cooler saves the current settings.
- The power LED is no longer illuminated.

i When the parking cooler is in BOOST mode and switched off, it will start the next time in AUTO mode. A timer is set to 0 by switching the parking cooler off. If the parking cooler is switched off while the compressor is still operating, the fan will continue to run for 20 seconds to dry the evaporator.

10.4 Using Menus

You can set the parking cooler to suit your requirements using the menus.

1. Press the **List** button to browse through the menus.
2. Press the **Up** or **Down** button to navigate to the appropriate sub-menu or to change the selected value.
3. Press the **Down** button to reduce the selected value.
4. Press the **Up** button to increase the selected value.

i The parking cooler switches off completely after 12 hours in standby mode to save power.

10.5 Using the Air Conditioner

1. Set the required temperature. Refer to “Setting the Temperature” on page 19.
2. Set the required mode. Refer to “Setting the Mode” on page 19.

i If the required temperature is not reached in the energy-saving mode or at a low fan speed, increase the fan speed or switch to BOOST mode or to AUTO mode.

3. Set the timer if you want the parking cooler to switch off automatically after the required time.

10.6 Setting the Temperature

i Depending on the set unit for the temperature, the temperature is changed in steps of either 2 °F or 1 °C.

10.6.1 Setting the Temperature Using the Control Panel

1. Press the **List** button until the thermometer symbol is displayed.
2. Press the **Up** or **Down** button to set the desired temperature.
3. Press the **List** button to save the value.

10.6.2 Setting the Temperature Using the Remote Control

1. Press the **Temperature Increase** button to increase the temperature.
2. Press the **Temperature Decrease** button to decrease the temperature.
3. To save the value, do not press any button for more than 5 seconds.

10.7 Setting the Mode

Use this section to set the mode on the control panel or the remote control.

10.7.1 Setting the Mode Using the Control Panel

To set the mode from the control panel:

1. Press the **List** button until the M symbol is displayed.
2. Press the **Up** or **Down** button to set the AUTO, ECO or BOOST mode.
3. To set the MANUAL mode see below.
4. Press the **List** button to start the selected mode.

If you want to set the fan speed manually (MANUAL mode) do the following:

1. Press the **List** button until the fan symbol is displayed.
2. Press the **Up** or **Down** button to set the desired fan speed. At the same time the MANUAL mode is started.
3. Press the **List** button to save the value.

If you want to leave the MANUAL mode:

1. Press the **List** button until the M symbol is displayed.
2. Press the **Up** button to leave the MANUAL mode. The BOOST mode is started.
3. Press the **Up** button once to set the ECO mode.
4. Press the **Up** button twice to set the AUTO mode.

10.7.2 Setting the Mode Using the Remote Control

To set the mode using the remote control:

- Press the **A** button to set the AUTO mode.
- Press the **E** button to set the ECO mode.
- Press the **B** button to set the BOOST mode.
- Press the **Fan Speed Increase** button to increase the fan speed manually and to start the MANUAL mode.
- Press the **Fan Speed Decrease** button to decrease the fan speed manually and to start the MANUAL mode.
- To start the selected mode, do not press any button for more than 5 seconds.

10.8 Setting the Timer

The parking cooler is equipped with a timer. Once the set time has elapsed on the timer, the parking cooler automatically switches off.

If the timer is activated, the display alternates between the set temperature and the duration.

10.8.1 Setting the Timer Using the Control Panel

To set the timer using the control panel:

1. Press the **List** button until the clock symbol appears.
2. Press the **Up** or **Down** button to set the timer in 10 minute intervals.
3. Press the **List** button to save the setting.

10.8.2 Setting the Timer Using the Remote Control

To set the timer using the remote control:

1. Press the **Clock** button to increase the required running time of the timer in ten minute intervals. The maximum run time is 600 minutes.
2. To save the value, do not press any button for more than 5 seconds.

To reset the timer to zero minutes:



1. Press the **Clock** button until the timer shows 600 minutes.
2. Press the **Clock** button again.
3. To save the value, do not press any button for more than five seconds.

11 Display Messages

 When you start the vehicle or switch on several devices at once, the display text "LO" may briefly appear.

11.1 Control Panel Warnings

Refer to this section for any questions regarding warning messages that are observed on the control panel.

Display Indication	Description	Cause	Remedy
LO 	The battery monitor has detected low voltage.	Connection voltage is too low. The battery capacity is not sufficient to operate the system.	<ul style="list-style-type: none"> • Charge your vehicle battery. • If the fault occurs again, contact an authorized dealer.
LO °F / °C	The system has detected that the ambient temperature is too low for operation.	The ambient temperature is below 41 °F (5 °C).	Wait until the ambient temperature has risen above 41 °F (5 °C) before switching the system on.
HI 	The system has detected a brief or constant over-voltage.	A brief over-voltage may occur when large electrical devices are switched off. Constant over-voltage is the result of an incorrect connection voltage.	<ul style="list-style-type: none"> • Brief over-voltage: No action required. • If the display message "HI" remains visible for a longer period: have the vehicle electronics checked. Make sure the connection voltage is less than 16 V.
---	The system has detected an excessive inclination. The compressor is switched off. Ten minutes later, the entire system will be switched off.	The compressor in the driver's cab is tilted too far.	Once the compressor has been returned to its normal position, the system can be switched on again.

Display Indication	Description	Cause	Remedy
— 	When operating for the first time, the battery symbol briefly flashes twice every 5 seconds. This indicates an incorrect connection of the battery sensor cable.	The system cannot measure the battery voltage.	Consult an authorized dealer and have the battery connection checked.

11.2 Control Panel Fault Messages

Refer to this section when a fault message is observed.

Display Text	Description	Cause	Remedy
F01	The compressor does not work.	An error in the compressor sensor electrical supply (open circuit) was detected.	<ul style="list-style-type: none"> • Switch off the system. • Switch it on again after 30 minutes.
F02			
F03		The compressor is overloaded.	
F04	The condenser fan 1 does not work.	There is no response from the fan.	If the fault occurs again, contact an authorized dealer.
F05	The condenser fan 1 is overloaded.	The fan speed is faulty.	
F06	The condenser fan 2 does not work.	There is no response from the fan.	
F07	The condenser fan 2 is overloaded.	The fan speed is faulty.	
F08	The evaporator fan does not work.	There is no response from the fan.	
F09	The evaporator fan is overloaded.	The fan speed is faulty.	
F10	N/A		
F11	The system cannot determine the internal temperature.	An error in the temperature sensor electrical supply (open circuit) was detected.	
F12			
F13	The system cannot determine the external temperature.	An error in the temperature sensor electrical supply (open circuit) was detected.	
F14			
F15	The system cannot determine the compressor temperature.	An error in the temperature sensor electrical supply (open circuit) was detected.	If the fault occurs again, contact an authorized dealer.
F16			
F17	The compressor temperature is too high.	Compressor thermal overload.	
F18	Saved for future use.	N/A	N/A
F19	Saved for future use.	N/A	N/A

Display Text	Description	Cause	Remedy
F20	The system reports a (temporary) electrical overload.	The system's current power requirement is too high.	If the fault occurs again, contact an authorized dealer.
F21	The control PCB is not working.	A control PCB communication error was detected.	
F22	The display board is not working.	A display board communication error (fault in the connecting cable between the display and control board) was detected.	
F23	Over temperature protection on heat sink, temperature too high.	Temperature too high.	

12 System Specifications

This section shows the system specification for the RTX 1000 and the RTX 2000 parking coolers.

	RTX 1000 12 V	RTX 2000 12 V
Cooling Capacity	1200 W	2000 W
Voltage	12 V (10 V–15 V)	
Current Consumption	10 A–50 A	10 A–58 A
Operating Temperature Range	41 °F to 126 °F (5 °C to 52 °C)	
Refrigerant	R-134a	
Refrigerant Quantity	350 g	850 g
CO ₂ Equivalent	0.5005 t	1.21 t
Global Warming Potential (GWP)	1430	
Noise Emission	< 70 dB(A)	
Dimensions	33.8 in. x 25.4 in. x 12.1 in. (860mm x 645 mm x 308 mm)	
Weight	Approximately 52.8 lbs (24 kg)	Approximately 72.6 lbs (33 kg)

13 Cleaning and Maintenance

Use this section for the cleaning and maintenance of your parking cooler.

NOTICE: Do **not** use abrasive cleaning agents or hard objects or flammable agents during cleaning as these can damage the unit.

 The parking cooler may be cleaned with a high-pressure cleaner.

Clean the housing of the parking cooler and the outlet panel occasionally with a damp cloth.

Remove leaves and other dirt from the ventilation grilles of the parking cooler occasionally. Make sure you do not damage the system in the process.

Regularly check that all the elements for the air conditioning unit are fastened.

Regularly check that the connection lines are undamaged and secure.

14 Disposal



Place the packaging material in the appropriate recycling waste bins, whenever possible. Consult a local recycling center or specialist dealer for details about how to dispose of the product in accordance with all applicable national and local regulations.

LIMITED ONE-YEAR WARRANTY

LIMITED ONE-YEAR WARRANTY AVAILABLE AT
WWW.DOMETIC.COM/WARRANTY.

IF YOU HAVE QUESTIONS, OR TO OBTAIN A COPY OF THE LIMITED WARRANTY FREE OF CHARGE, CONTACT:

DOMETIC CORPORATION
CUSTOMER SUPPORT CENTER
5155 VERDANT DRIVE
ELKHART, INDIANA, USA 46516
1-800-544-4881 OPT 1