

LORD Hausgeräte GmbH
Greschbachstraße 17
76229 Karlsruhe
Germany
info@lord.eu
www.lord.eu

Misprints reserved



Content



FREESTANDING APPLIANCES

WASHING MACHINES	W1	3
	W2	5
	W3	7
	W4	9
	W5	11
DRYER	T1	13
DISHWASHER	D3	15
FRIDGE-FREEZERS	C1	17
	C2	19
FREEZER	F1	21
MICROWAVE OVEN	M4	23
	M3	25
	M2	27

BUILT-IN APPLIANCES

OVENS	B3	29
	B1	31
	B2	33
MICROWAVE OVENS	M1	35
	M5	37
HOBS	H1	39
	H2	41
AIR FILTERS	AF1	43
	AF2	45
	AF3	47
FRIDGE-FREEZER	C3	49
DISHWASHERS	D1	51
	D2	53

PROFESSIONAL APPLIANCES

REFRIGERATOR	PR1	55
FREEZER	PF1	55
ACCESSORIES		57

ILLUSTRATIONS FOR BUILT-IN INSTALLATION		58
---	--	----

Washing Machine 60 cm – W1

- Category: freestanding
- Water consumption: 9,900 l/year
- Washing/spinning noise: 49/74 dB
- Power consumption: 137 kWh/year
- Energy efficiency class: A+++ -30 %
- Washing efficiency class: A
- Spinning efficiency class: B
- Maximum load: 8 kg
- Maximum spin speed: 1,400/min
- 15 programs
- Touchscreen with additional functions (Time delay, Start/Pause with a reload function, Easy Iron, Spin speed selection, Speed/Eco)
- Setting the end of a program max. 24 h
- The indicator of remaining time to the end of the program
- Child safety lock
- Visual and acoustic indicator of the end of the program
- LED - Display (LED colour: Amber)
- Multiple protection against water damage
- BLDC inverter motor

Dimensions: (HxWxD) 84.8x59.8x62 cm

- **Optional additional accessories:** SK1 - connecting piece with extension, SK2 - connecting piece. See pg. 57.

Washing programs W1

1	Cottons 20°C	9	AllergyPlus / Hygiene
2	Cottons 40°C	10	Drain / Spinning
3	Cottons 60°C	11	Extra rinse / Starching
4	Cottons 90°C	12	Easy iron
5	Easy care 30°C	13	Quick wash / Mixture
6	Easy care 40°C	14	Outdoor
7	Delicates / Silk 30°C	15	Rapid 15/30 min
8	Woolens / Handwash 30°C		

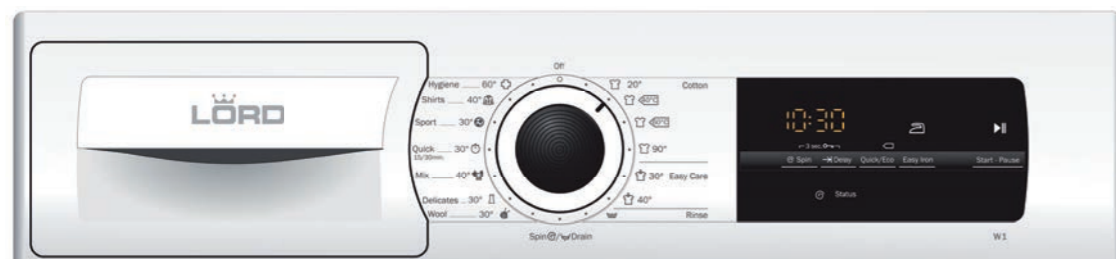

Washing Machine 60 cm – **W2**

- Category: freestanding
- Water consumption: 9,900 l/year
- Washing/spinning noise: 50/74 dB
- Power consumption: 137 kWh/year
- Energy efficiency class: A+++ -30 %
- Washing efficiency class: A
- Spinning efficiency class: B
- Maximum load: 8 kg
- Maximum spin speed: 1,200/min
- 15 programs
- Touchscreen with additional functions (Time delay, Start/Pause with a reload function, Easy iron, Spin speed selection, Speed/Eco)
- Setting the end of a program max. 24 h
- The indicator of remaining time to the end of the program
- Child safety lock
- Visual and acoustic indicator of the end of the program
- LED - Display (LED colour: Amber)
- Multiple protection against water damage
- BLDC inverter motor

Dimensions: (HxWxD) 84.8x59.8x62 cm

- **Optional additional accessories:** SK1 - connecting piece with extension, SK2 - connecting piece. See pg. 57.

Washing programs W2

1	Cottons 20°C	9	AllergyPlus / Hygiene
2	Cottons 40°C	10	Drain / Spinning
3	Cottons 60°C	11	Extra rinse / Starching
4	Cottons 90°C	12	Easy iron
5	Easy care 30°C	13	Quick wash / Mixture
6	Easy care 40°C	14	Outdoor
7	Delicates / Silk 30°C	15	Rapid 15/30 min
8	Woollens / Handwash 30°C		

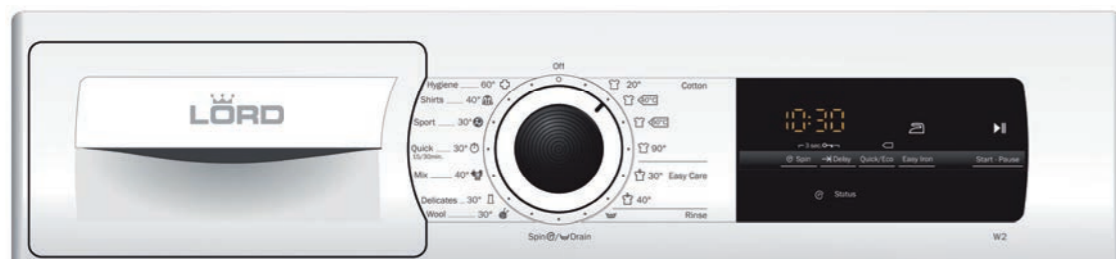

Washing Machine 60 cm – **W3**

- Category: freestanding
- Water consumption: 9,020 l/year
- Washing/spinning noise: 54/74 dB
- Power consumption: 157 kWh/year
- Energy efficiency class: A+++ -10 %
- Washing efficiency class: A
- Spinning efficiency class: B
- Maximum load: 7 kg
- Maximum spin speed: 1,200/min
- 15 programs
- Touchscreen with additional functions (Speed selection, Speed/Eco, Time delay, Start/Pause with a reload function)
- Setting the end of a program max. 24 h
- The indicator of remaining time to the end of the program
- Child safety lock
- Visual and acoustic indicator of the end of the program
- LED - Display (LED colour: Amber)
- Multiple protection against water damage
- BLDC inverter motor

Dimensions: (HxWxD) 84.8x60x59 cm

- **Optional additional accessories:** SK1 - connecting piece with extension, SK2 - connecting piece. See pg. 57.

Washing programs W3

1	Cottons 20°C	9	Easy care 40°C
2	Cottons 40°C	10	Delicates / Silk 30°C
3	Cottons 40°C Eco	11	Woolens / Handwash 30°C
4	Cottons 40°C prewash	12	Extra rinse / Starching
5	Cottons 60°C	13	Rapid 15/30 min
6	Cottons 60°C Eco	14	Quick wash / Mixture
7	Cottons 90°C	15	Drain / Spinning
8	Easy care 20°C		

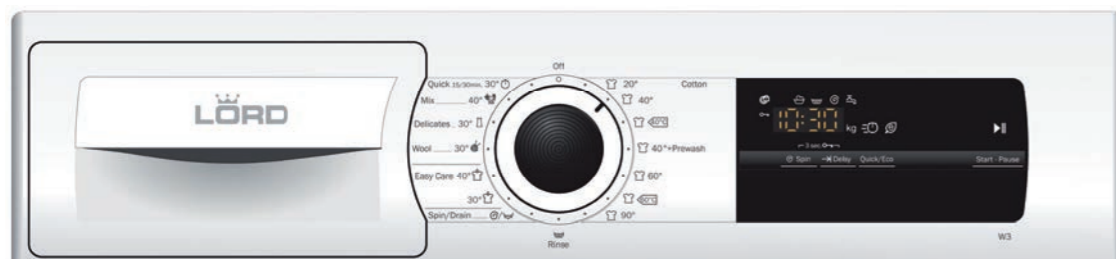

Washing Machine 60 cm – W4

- Category: freestanding
- Water consumption: 10,686 l/year
- Washing/spinning noise: 59/76 dB
- Power consumption: 156 kWh/year
- Energy efficiency class: A+++
- Washing efficiency class: A
- Spinning efficiency class: C
- Maximum load: 7 kg
- Maximum spin speed: 1,200/min
- 15 programs
- Control buttons: 5: (Start/Pause, Speed, Time delay max. 24 h, Rinse plus, Temperature)
- The indicator of remaining time to the end of the program
- Visual indicator of the end of the program
- Child safety lock
- LED - Display (LED colour: Red)
- Multiple protection against water damage

Dimensions: (HxWxD) 84.8 x 59.8 x 59 cm

Washing programs W4

1	Cottons	9	Woolens / Handwash
2	SpeedPerfect	10	Delicates / Silk
3	EcoPerfect	11	Quick wash / Mixture
4	Prewash	12	Quick wash + Prewash
5	Easy iron	13	Quick wash + EcoPerfect
6	Rinsing / Spinning	14	Quick wash + SpeedPerfect
7	Drain	15	Easy care
8	Rapid 15 min		



Washing Machine 45 cm – W5

- Category: freestanding
- Water consumption: 8,800 l/year
- Washing/spinning noise: 52/75 dB
- Power consumption: 147 kWh/year
- Energy efficiency class: A+++ -10 %
- Washing efficiency class: A
- Spinning efficiency class: B
- Maximum load: 6,5 kg
- Maximum spin speed: 1,200/min
- 15 programs
- Touchscreen with additional functions (Temperature, Speed selection, Time delay, Quick/Eco, Water rinse*, Prewash, Start/Pause with a reload function)
- Automatic load sensor
- Unbalanced load detection system
- Foam control
- Multiple water protection
- Anti-crease phase at program end
- VarioSoft Drum
- Voltage check
- Setting the end of a program max. 24 h
- The indicator of remaining time to the end of the program
- Child safety lock
- Visual and acoustic indicator of the end of the program
- LED - Display (LED colour: Amber)
- BLDC inverter motor

Dimensions: (HxWxD) 84.8 x 59.8 x 44,6 cm

Washing programs W5

1	Cotton	9	Spin/Drain
2	Cotton Eco	10	Duvets
3	Easy Care	11	Shirts
4	Delicates	12	Lingerie
5	Wool	13	Outdoor
6	Quick/Mix	14	Quick 60min.
7	Dark Clothes	15	Quick 15/30min.
8	Rinse		



Heatpump Dryer – T1

- Category: freestanding
- Drying program noise 65 dB
- Power consumption: 236 kWh/year
- Energy efficiency class: A++
- Maximum load: 8 kg
- 15 programs
- Touchscreen with additional features (Gentle drying, Start/Pause, Easy iron, Programme length, Low temperature, Time delay max 24 h)
- The indicator of remaining time to the end of the program
- Easy-to-clean filter
- Child safety lock
- Visual and acoustic indicator of the end of the program
- LED - Display (LED colour: Amber)
- Drum interior material: stainless steel

Dimensions: (H x W x D) 84.8 x 59.8 x 63.6 cm

- **Optional additional accessories:** SK1 - connecting piece with extension, SK2 - connecting piece, Condensate drain, Basket for woollens. See pg. 57.

Drying programs

Easy care	Iron-dry	Additional programmes	Mixture
	Cupboard-dry		Sportswear
	Cupboard-dry extra		Super 40
White / Coloured	Iron-dry	Timed 30 min. cold	
	Cupboard-dry	Timed 30 min. warm	
	Cupboard-dry extra	Cottons	
		Downs	
		Shirts / Blouses	
		Towels	

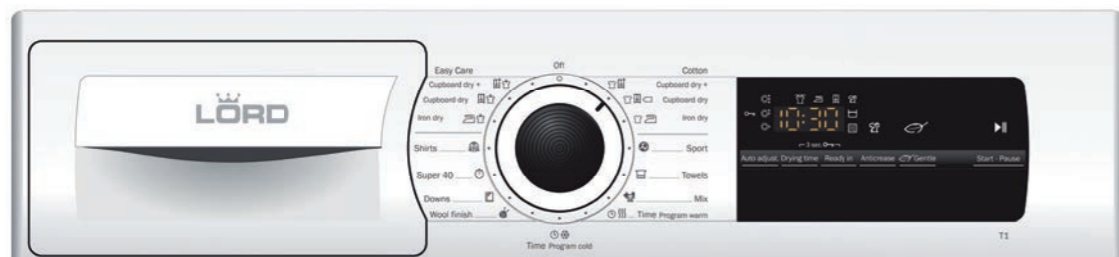

Dishwasher 60 cm – D3

- Category: freestanding
- Energy efficiency class: A++ (A/A)
- Energy label: consumption 9.5 l (2.660 l), 0.93 kWh (266.0 kWh)
- Noise level: 44 dB
- Capacity: 14 dining sets in 3 levels (Lower basket + Upper basket + Cutlery drawer)
- 5 programs: Intensive 70°C, Automatic 45-65°C, Economy 50°C, Quick Wash 45°C, Pre Rinse
- Load sensor, water sensor
- Time save (Vario Speed), half loading
- Delayed start max. 24 h
- The indicator of remaining time to the end of the cycle
- Dosing assistant
- Self-cleaning filter system with triple corrugated filter
- LED - Display (LED colour: Amber)
- Triple Water Protection 24 h (AquaStop)
- Inner walls: stainless steel
- BLDC inverter motor

Dimensions: (H x W x D) 84.5 x 60 x 60 cm



VarioFlex basket



Cutlery basket



Upper basket

- Height-adjustable
- 3 levels (Rackmatic)
- 2 folding elements



Lower basket

- 2 folding elements



NoFrost fridge-freezer – C1

- Category: freestanding
- Energy efficiency class: A++
- Energy consumption: 273 kWh/year
- Total net capacity: 366 l
- Refrigerator net capacity: 279 l
- Freezer net capacity: 87 l
- Noise level: 39 dB (A) re 1 pW
- Climate class: SN-T (+10°C to +43°C)
- Electronic control:
 - electronic temperature setting TouchControl
 - LCD digital temperature display for fridge and freezer on door
 - rapid cooling
 - rapid freezing
 - visual and audible alarm

Refrigerator compartment

- Automatic defrost
- ExtraFresh plus zone with humidity control for fruit and vegetable
- ExtraCold plus zone for fish and meat: 2
- LED light with soft start
- Number of shelves: 5
 - which of them adjustable: 3
- Material of the shelves: safety glass
- Bottle rack
- No. of door shelves: 4
- No. of egg racks: 3

Freezer compartment ❄️❄️❄️

- Automatic defrost - NoFrost
- Freezing capacity: 14 kg/24 h
- Storage period in event of power failure: 16 h
- Drawers: 3
- Cold accumulators: 2
- Ice cube tray with cover: 1
- Door opened indicator

Features

- Multi-Flow Air Tower
- Air-Fresh-Filter
- AntiBacterial
- Colour & finish of doors: inox-easyclean
- Colour & finish of side walls: chrome Inox-metallic
- 2 independent cooling circuits
- Number of compressors: 1
- Door hinges: right reversible
- Front adjustable feet
- Coolant: R600a - isobutane
- Length of electrical supply cord: 240 cm

Dimensions: (H x W x D) 203 x 60 x 66 cm



NoFrost fridge-freezer — C2

- Category: freestanding
- Energy consumption: A++
- Power consumption: 235 kWh/year
- Total net capacity: 302 l
- Refrigerator net capacity: 215 l
- Freezer net capacity: 87 l
- Noise level: 42 dB (A) re 1 pW
- Climate class: SN-T (+10°C to +43°C)
- Control:
 - mechanical control in refrigerator
 - LED temperature display for freezer
 - rapid freezing
 - visual and audible alarm
 - visual and audible door opened signal

Refrigerator compartment

- Automatic defrost
- Fresh drawer for fruit and vegetable
- LED light with soft start
- Number of shelves: 4
 - which of them adjustable: 3
- Material of the shelves: safety glass
- No. of door shelves: 4
- No. of egg racks: 3

Freezer compartment



- Automatic defrost - NoFrost
- Freezing capacity: 11 kg/24 h
 - Storage period in event of power failure: 19 h
 - Drawers: 3
 - Ice cube tray with cover: 1
 - Door opened indicator

Features

- Multi-Flow Air Tower
- Product colour: white
- Door hinges: right reversible
- Integrated horizontal door handle
- Front adjustable feet
- Coolant: R600a - isobutane
- Length of electrical supply cord: 240 cm

Dimensions: (H x W x D) 186 x 60 x 66 cm



Upright NoFrost freezer – F1

- Category: freestanding
- Energy efficiency class: A++
- Energy consumption: 234 kWh/year
- Total net capacity: 237 l
- Noise level: 42 dB (A) re 1 pW
- Climate class: SN-T (+10°C to +43°C)
- Electronic control:
 - electronic temperature setting
 - LED temperature display
 - rapid freezing
 - visual and audible alarm
 - audible door opened indicator

Freezer compartment ********

- Automatic defrost - NoFrost
- Freezing capacity: 20 kg/24 h
- Storage period in event of power failure: 19 h
- Freezing flaps: 2
- Drawers: 5
 - which of them BigBox: 2
- Cold accumulators: 2
- Ice cube tray: 1

Features

- Product colour: white
- Vertical bar door handle
- Door hinges: right reversible
- Front adjustable feet
- Coolant: R600a - isobutane
- Length of electrical supply cord: 230 cm

Dimensions: (H x W x D) 186 x 60 x 65 cm



Microwave Oven – M4

- Category: freestanding
- Type: 4 in 1 (Microwave, Double grill, Hot air)
- Cavity capacity: 25 l
- Rotary knob: extremely easy and comfortable control
- Control: electronic
- Clock: digital
- Automatic programs: 10
- Child safety
- Defrost: automatic
- Memory function
- Quick-Start function
- Timer: 95 min with acoustic signal
- Microwave power level: 900 W in 11 levels
- Double grill power: 1600 W
- Type of grill: quartz
- Hot air power: 2500 W
- Door opening: handle, stainless steel
- Hinges: left
- Turntable: Ø 31.5 cm
- Turntable: Crispy Pizza Plate
- Colour: silver
- Front material: glass
- Interior light on right side
- Cavity material: stainless steel
- Safety:
 - Automatic switch off
 - Door contact switch
 - Integral cooling fan
- Included accessories: 1 x grid, 1 x turntable
- Length of electrical supply cord: 100 cm

Dimensions: (H x W x D) 30,7 x 51,3 x 50,0 cm



Microwave Oven – M3

- Category: freestanding
- Type: 3 in 1 (Microwave, Grill, Hot air)
- Cavity capacity: 25 l
- Rotary knob: extremely easy and comfortable control
- Control: electronic
- Clock: digital multifunction
- Automatic programs: 10
- Child safety
- Defrost: automatic
- Memory function
- Quick-Start function
- Timer: 95 min with acoustic signal
- Microwave power level: 900 W in 5 levels
- Double Grill power: 1100 W
- Type of grill: quartz
- Hot air power: 2500 W
- Door opening: button
- Hinges: left
- Turntable: Ø 31.5 cm
- Turntable material: glass
- Colour: black
- Front material: glass
- Interior light on right side
- Cavity material: stainless steel
- Safety:
 - Automatic switch off
 - Door contact switch
 - Integral cooling fan
- Included accessories: 1 x grid, 1 x turntable
- Length of electrical supply cord: 100 cm

Dimensions: (H x W x D) 30,7 x 51,3 x 50,0 cm



Microwave Oven – M2

- Category: freestanding
- Type: 2 in 1 (Microwave, Grill)
- Cavity capacity: 20 l
- Rotary knob: extremely easy and comfortable control
- Control: electronic
- Clock: digital
- Automatic programs: 8
- Child safety
- Defrost: automatic
- Memory function
- Quick-Start function
- Timer: 95 min with acoustic signal
- Microwave power level: 800 W in 5 levels
- Grill power: 1000 W
- Type of grill: quartz
- Door opening: button
- Hinges: left
- Turntable: Ø 24.5 cm
- Turntable material: glass
- Colour: stainless steel
- Front material: glass
- Interior light on right side
- Cavity material: stainless steel
- Safety:
 - Automatic switch off
 - Door contact switch
 - Integral cooling fan
- Included accessories: 1 x turntable
- Length of electrical supply cord: 100 cm

Dimensions: (H x W x D) 29,0 x 46,1 x 35,9 cm



Pyrolytic Oven – B3

- Category: built-in
- Energy efficiency class: A
- Energy consumption conventional heating: 1,02 kWh
- Energy consumption forced air convection: 0,81 kWh
- Cavity capacity: 71 l
- LED electronic control:
- Touch control
- Electronic functions:
 - Actual temperature display
 - Automatic temperature proposal
 - Heating-up control
 - Timer
- 40 automatic programmes
- 12 heating modes:
 - Bottom heat
 - Conventional heat
 - Defrost
 - Full width grill
 - Half width grill
 - Hot air soft
 - Hot air
 - Hot air grilling
 - Intensive heat
 - Pizza setting
 - Pre-heating
 - Warming
- Safety:
 - Childproof lock
 - Door lock electrical
 - Safety switch-off function oven
 - Start button
 - Quadruple glazing
 - Soft closing door
- 2-level full extension railing system
- Halogen interior light on top
- Pyrolytic integrated self cleaning system
- Colour: black
- Front material: glass
- Metal bar handle
- Max. temperature: 275 °C
- Included accessories: 1 x combination grid, 1 x enamel baking tray, 1 x universal pan
- Length of electrical supply cord: 120 cm

Dimensions: (H x W x D) 59.5 x 59.4 x 54.8 cm

- **Optional additional accessories:** 3-stage telescopic extensions, Enamel baking tray, Universal pan, Combination grid. See pg. 57.



Pyrolytic Oven – B1

- Category: built-in
- Energy efficiency class: A -10 %
- Energy consumption conventional heating: 0,91 kWh
- Energy consumption forced air convection: 0,71 kWh
- Stainless steel control panel
- Push-pull control knob
- Cavity capacity: 57 l
- Electronic functions:
 - Digital display
 - Timer
 - Temperature recommendations & timer
 - Smooth side oven
 - Single row telescopic rails
 - Interior lighting
 - Cooling fan
- 8 heating modes:
 - Bottom heating
 - Circular heating
 - Circular heating eco
 - Conventional heating
 - Full-width variable grill
 - Half-width variable grill
 - Hot-air grilling
 - Pizza
- Safety:
 - Childproof lock
 - Door lock electrical
 - Safety switch-off function oven
 - Quadruple glazing
- Pyrolytic integrated self cleaning system
- Door colour: black
- Door material: glass
- Metal handle
- Max. temperature: 275 °C
- Accessories: 1x combination grid, 1x universal pan, suitable for pyrolytic cleaning

Dimensions: (H x W x D) 59.5 x 59.5 x 51.5 cm

- **Optional additional accessories:** 3-stage telescopic extensions, 1-stage telescopic extensions, Enamel baking tray, Universal pan, Combination grid. See pg. 57.



Multifunctional Oven – B2

- Category: built-in
- Energy efficiency class: A
- Energy consumption conventional heating: 0,85 kWh
- Energy consumption forced air convection: 0,79 kWh
- Stainless steel control panel
- 2 control knobs
- Cavity capacity: 61 l
- Electromechanical control
- Electronic Timer
- Oven with smooth sides & rails
- Ecolytic back panel
- Interior lighting
- Child safety lock
- 6 heating modes:
 - Circulating air
 - Bottom heating
 - Conventional heating
 - Hot-air grilling
 - Full-width grill
 - Pizza
- Door colour: black
- Door material: glass
- Metal handle
- Max. temperature: 275 °C
- Accessories: 1x enamel baking tray, 1x combination grid

Dimensions: (H x W x D) 59.5 x 59.5 x 51.5 cm

- **Optional additional accessories:** 3-stage telescopic extensions, 1-stage telescopic extensions, Enamel baking tray, Universal pan, Combination grid. See pg. 57.



Microwave Oven – M1

- Category: built-in
- Cavity capacity: 20 l
- Rotary knob: extremely easy and comfortable control
- Timer
- Microwave power level: 800 W in 5 levels
- Grill power: 1000 W
- Type of grill: quartz
- Door opening: button
- Hinges: left
- Turntable: Ø 25.5 cm
- Turntable material: glass
- Colour: black
- Front material: glass
- Interior light on right side
- Cavity material: stainless steel
- Safety:
 - Automatic switch off
 - Door contact switch
 - Integral cooling fan
- Included accessories: 1 x grid, 1 x turntable
- Length of electrical supply cord: 130 cm

Dimensions: (H x W x D) 38.2 x 59.4 x 31.7 cm



Microwave Oven – M5

- Category: built-in
- Cavity capacity: 20 l
- Rotary knob: extremely easy and comfortable control
- Timer
- Microwave power level: 800 W in 5 levels
- Grill power: 1000 W
- Type of grill: quartz
- Door opening: button
- Hinges: left
- Turntable: Ø 24.5 cm
- Turntable material: glass
- Colour: stainless steel
- Front material: glass/stainless steel
- Interior light on right side
- Cavity material: stainless steel
- Safety:
 - Automatic switch off
 - Door contact switch
 - Integral cooling fan
- Included accessories: 1 x grid, 1 x turntable
- Length of electrical supply cord: 100 cm

Dimensions: (H x W x D) 38.8 x 59.5 x 34.4 cm



Induction Hob – H1

- Category: built-in

Glass-ceramic induction hob

- KeraBlack +
- Rounded edges
- Performance of cooking zones
 - Front left: 220 x 180 mm, 2100 / 2600 / 3700 W
 - Rear left: 220 x 180 mm, 2100 / 2600 / 3700 W
 - Front right: 220 x 180 mm, 2100 / 2600 / 3700 W
 - Rear right: 220 x 180 mm, 2100 / 2600 / 3700 W

Control

- Slider touch control with 12 levels of power setting (0-9 + Booster, Double Booster, Keep warm)
- Long-lasting touch technology (no oxidation)
- Capacitive technology with patented foam elements for greater reliability
- 2 large cooking zones
- 4x Booster function (for all cooking zones)
- 4x Double Booster (for all cooking zones)
- 4 simultaneously-usable timers + countdown timer function
- Child safety lock
- Quick heat up of the zone function
- Auto cooking function - maintaining the temperature at 42 °C, 70 °C, 94 °C
- Pause function
- Restart function

Installation

- 400 V / 2N (2 phases) 50/60 Hz power supply
- Power input of 7400 W
- Supplied with sealing
- Power cable

Security features

- Detection of faulty electrical connections
- Detection of under-voltage and over-voltage in the power supply
- Detection of the presence of cookware
- Detection of the suitability of cookware
- Detection of the presence of fluids on control electronics
- Detection of critical temperature overrun
- Detection of forgetting to turn off
- Detection of residual temperature of the cooking zone
- Child safety - Locking the control functions
- Detection of insufficient ventilation in the area under the hob

Eco-design

- Standby consumption <0.5 W

Dimensions: (H x W x D) 5.2 x 59 x 52 cm

- **Optional additional accessories:** Decorative side bar. See pg. 57.

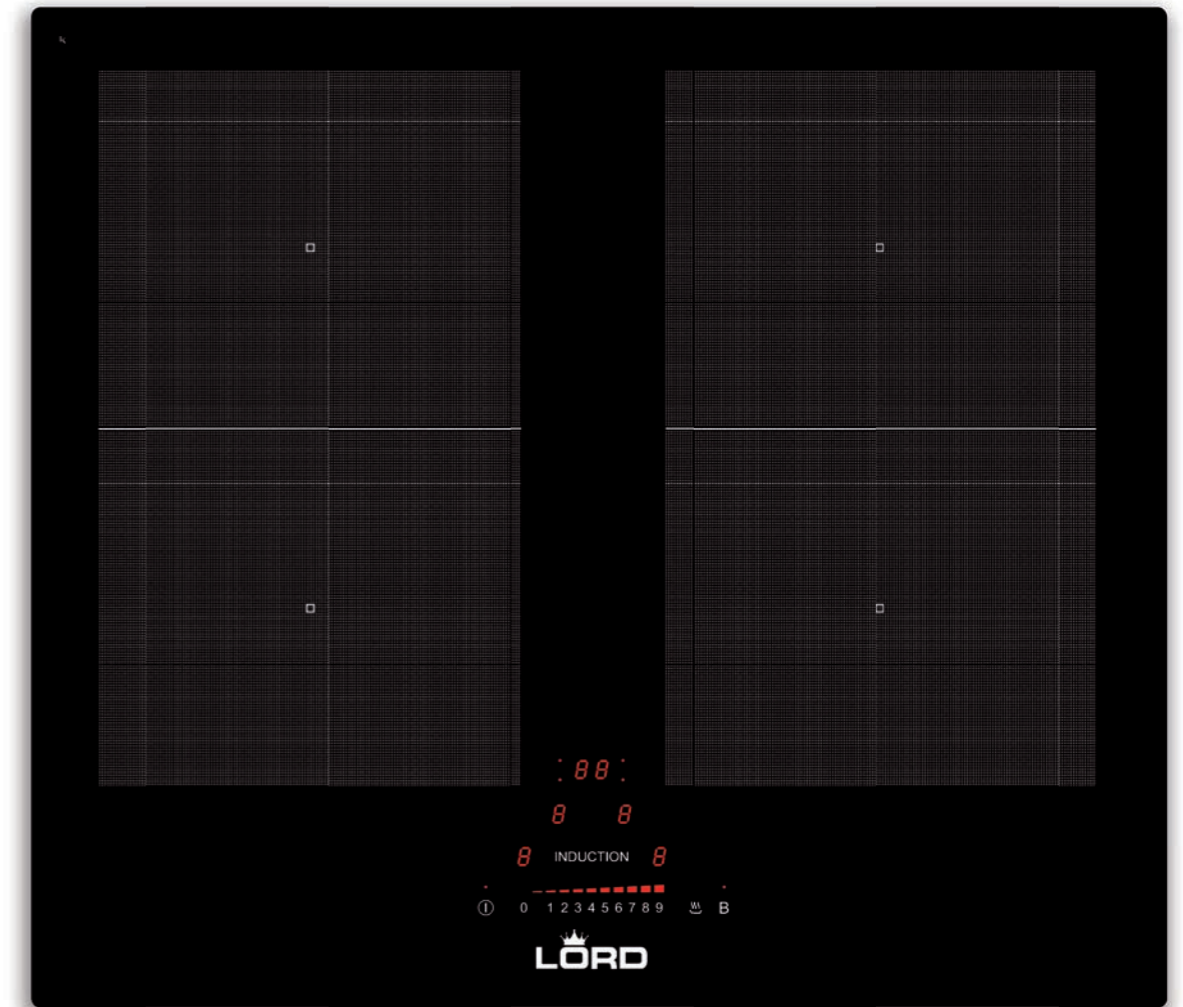

Induction Hob – H2

- Category: built-in

Glass-ceramic induction hob

- KeraBlack +
- Rounded edges
- Performance of cooking zones
 - Front left: 200 mm, 1850 / 2300 / 3000 W
 - Rear left: 200 mm, 1850 / 2300 / 3000 W
 - Front right: 230 mm, 2100 / 2600 / 3700 W
 - Rear right: 200 mm, 1850 / 2300 / 3000 W

Control

- Slider touch control with 12 levels of power setting (0-9 + Booster, Double Booster; Keep warm)
- Long-lasting touch technology (no oxidation)
- Capacitive technology with patented foam elements for greater reliability
- 1 large cooking zone
- 4x Booster function (for all cooking zones)
- 4x Double Booster (for all cooking zones)
- 4 simultaneously-usable timers + countdown timer function
- Child safety lock
- Quick heat up of the zone function
- Auto cooking function - maintaining the temperature at 42 °C and 70 °C
- Pause function
- Restart function

Installation

- 400 V / 2N (2 phases) 50/60 Hz power supply
- Power input of 7400 W
- Supplied with sealing
- Power cable

Security features

- Detection of faulty electrical connections
- Detection of under-voltage and over-voltage in the power supply
- Detection of the presence of cookware
- Detection of the suitability of cookware
- Detection of the presence of fluids on control electronics
- Detection of critical temperature overrun
- Detection of forgetting to turn off
- Detection of residual temperature of the cooking zone
- Child safety - Locking the control functions
- Detection of insufficient ventilation in the area under the hob

Eco-design

- Standby consumption <0.5 W

Dimensions: (H x W x D) 5.2 x 59 x 52 cm

- **Optional additional accessories:** Decorative side bar. See pg. 57.

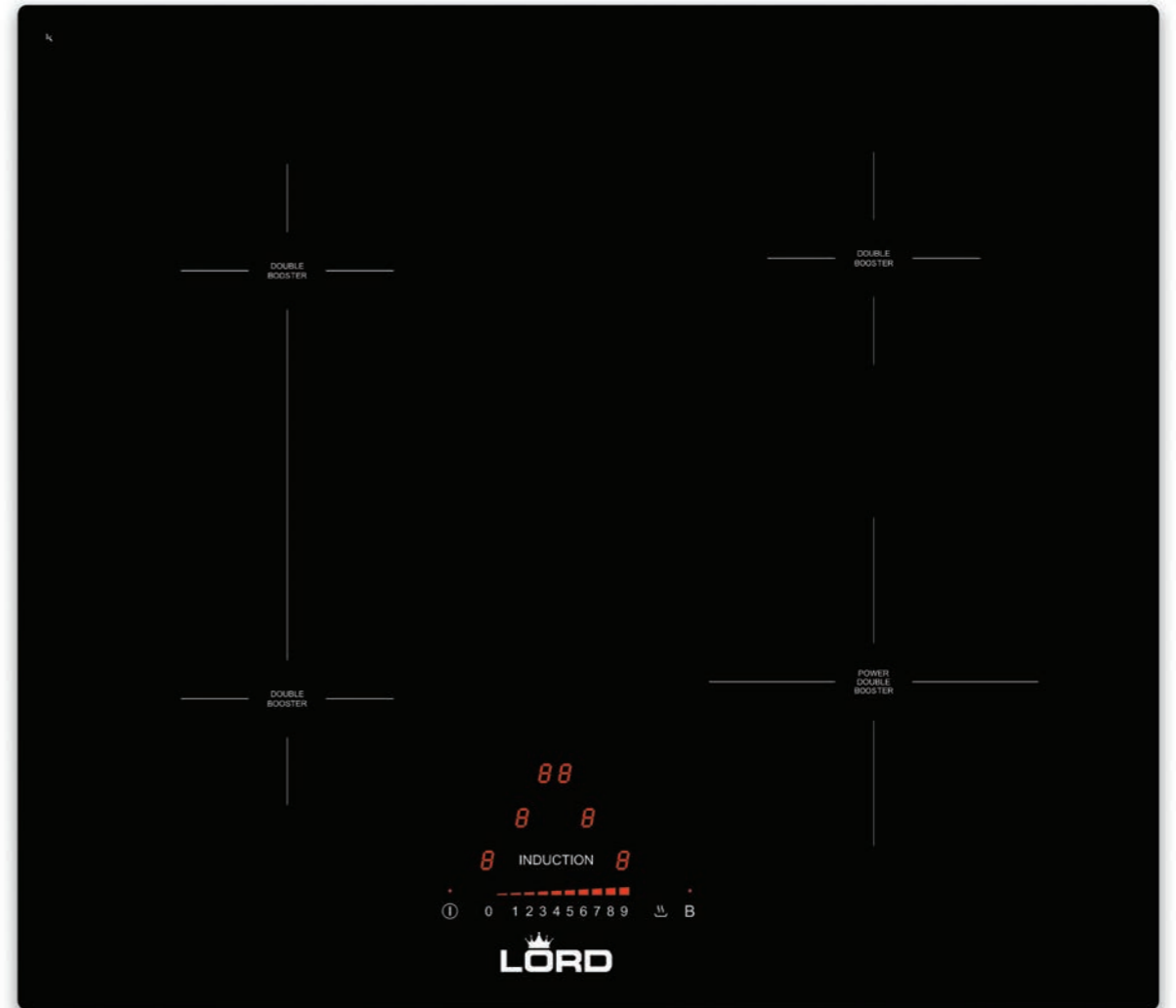

PlasmaMade Air Filter – **AF1**

- Mounting: 230 x 80 mm
- Max 1000 m³/h
- Plasma
- Electrostatic core
- Carbon filter
- High efficient air treatment of e.g.:
 - Airborne viruses
 - Bacteria
 - Mold
 - Tar and cigarette smoke
 - Nicotine
 - House dust mite
 - Pollen
 - Animal dander particles
 - Dust
- Lifetime (in years): 10–15 (based on use of 2 hours a day)
- Hours of operating mode: 9000
- Electrical connection: 240 V, 12 V
- Including mounting adapter:
 - 222 x 89 mm
 - 220 x 90 mm
 - 230 x 80 mm
- Mounting horizontally and vertically

Dimensions: (H x W x D) 9.6 x 34.1 x 37.2 cm



PlasmaMade Air Filter – **AF2**

- Mounting: Ø 150 mm
- Max 1000 m³/h
- Plasma
- Electrostatic core
- Carbon filter
- High efficient air treatment of e.g.:
 - Airborne viruses
 - Bacteria
 - Mold
 - Tar and cigarette smoke
 - Nicotine
 - House dust mite
 - Pollen
 - Animal dander particles
 - Dust
- Lifetime (in years): 10–15 (based on use of 2 hours a day)
- Hours of operating mode: 9000
- Electrical connection: 240 V, 12 V
- Including mounting adapter:
Ø150 mm
- Mounting horizontally and vertically

Dimensions: (H x W x D) 22 x Ø33 cm



PlasmaMade Air Filter – **AF3**

- Mounting: Ø 100 mm
- Max 600 m³/h
- Plasma
- Electrostatic core
- Carbon filter
- High efficient air treatment of e.g.:
 - Airborne viruses
 - Bacteria
 - Mold
 - Tar and cigarette smoke
 - Nicotine
 - House dust mite
 - Pollen
 - Animal dander particles
 - Dust
- Lifetime (in years): 10–15 (based on use of 2 hours a day)
- Hours of operating mode: 9000
- Electrical connection: 240 V, 12 V
- Including mounting adapter:
 - Ø150 mm
 - Ø100 mm
- Mounting horizontally and vertically

Dimensions: (H x W x D) 17 x Ø18 cm



NoFrost fridge-freezer — C3

- Category: built-in
- Energy efficiency class: A++
- Energy consumption: 221 kWh/year
- Total net capacity: 254 l
- Refrigerator net capacity: 187 l
- Freezer net capacity: 67 l
- Noise level: 39 dB (A) re 1 pW
- Climate class: SN-ST (+10°C to +38°C)
- Electronic control:
 - electronic temperature setting
 - 2x digital temperature display for fridge and freezer
 - rapid cooling
 - rapid freezing
 - holiday function
 - visual and audible alarm

Refrigerator compartment

- Automatic defrost
- Interior ventilator
- HyperFresh plus zone with humidity control
- LED light
- No. of shelves: 5
 - which of them adjustable: 4
- Material of the shelves: safety glass
- No. of door shelves: 5
- No. of egg racks: 3
- Bottle holder in door tray: 1

Freezer compartment ❄️❄️❄️

- Automatic defrost - NoFrost
- Freezing capacity: 12 kg/24h
- Storage period in event of power failure: 13 h
- Drawers: 3
 - which of them BigBox: 1
- VarioZone for storing bulky items
- Cold accumulators: 2
- Ice cube tray with cover: 1
- Ice cube tray: 1
- Door opened indicator

Features

- 2 independent cooling circuits
- Inverter compressor
- Door hinges: fixed; right reversible
- Coolant: R600a - isobutane
- Length of electrical supply cord: 230 cm

Dimensions: (H x W x D) 177.2 x 55.8 x 54.5 cm



Dishwasher 60 cm – D1

- Category: built-in
- Energy efficiency class: A++ (A/A)
- Energy label: consumption 9.5 l (2.660 l), 0.93 kWh (266.0 kWh)
- Noise level: 44 dB
- Capacity: 14 dining sets in 3 levels (Lower basket + Upper basket + Cutlery drawer)
- 5 programs: Intensive 70 °C, Automatic 45 °C - 65 °C, Economical 50 °C, Quick wash 45 °C, Pre Rinse
- Delayed start max. 24 h
- Dosing assistant
- Load sensor; water sensor; 3-in-1, water switch
- Time-Save (VarioSpeed), half loading
- Self-cleaning filter system with triple corrugated filter
- LED - Display (LED colour: red)
- Acoustic indicator of the end of a cycle
- Info-Light (beam on the floor)
- VarioFlex basket
- Triple Water Protection 24 h (AquaStop)
- Inner walls: stainless steel
- BLDC inverter motor

Dimensions: (H x W x D) 81.5 x 59.8 x 55 cm



VarioFlex basket



Cutlery basket



Upper basket

- Height-adjustable
- 3 levels (Rackmatic)
- 2 folding elements



Lower basket

- 2 folding elements



Dishwasher 45 cm – D2

- Category: built-in
- Energy efficiency class: A++ (A/A)
- Energy label: consumption 9.5 l (2.660 l), 0.75 kWh (211.0 kWh)
- Noise level: 44 dB
- Capacity: 10 dining sets in 3 levels (Lower basket + Upper basket + Cutlery drawer)
- 6 programs: Intensive 70 °C, Auto 45-65 °C, Economy 50 °C, Intense smart 45 °C, Quick Wash 45 °C, Pre Rinse
- Delayed start max. 24 h
- Dosing assistant
- Load sensor, water sensor, 3-in-1, water switch
- Time save (Vario Speed), half loading
- Self-cleaning filter system with triple corrugated filter
- Acoustic indicator of the end of a cycle
- Info-Light (beam on the floor)
- LED - Display (LED colour: Red)
- Triple Water Protection 24 h (AquaStop)
- Inner walls: stainless steel
- BLDC inverter motor

Dimensions: (H x W x D) 81.5 x 44.8 x 55 cm



VarioFlex basket



Cutlery basket



Upper basket

- Height-adjustable
- 3 levels (Rackmatic)
- 2 folding elements



Lower basket

- 2 folding elements



Refrigerator – PR1

- Category: Refrigerator for professional gastronomy
- Consumption: 621 kWh/year
- Power input: 1,6 A/260 W
- Gross volume: 650 l
- Cooling method: Dynamic
- Ambient operating temperature: +10 °C to +40 °C
- For GN 2/1, digital indicator with alarms - HACCP

Other features

- Gross weight: 140 kg
- Net weight: 120 kg
- Stainless steel casing and interior
- Cooling system: Dynamic
- Defrosting method: Automatic
- Control type: electronic control
- Temperature indicator: outer digital
- Operation indicator: yes
- Fault indicator: optical and acoustic
- Shelf material: GN 2/1 grates with plastic finish
- Number of shelves: 3
- of which height-adjustable: 3
- Ventilator: yes
- Temperature range: -0 °C to +12 °C
- Refrigerant: R290
- Handle: Integrated handle
- Adjustable feet: 4
- Feet material: stainless steel
- Lock: yes
- Self-closing doors: yes
- Voltage: 220-230 V
- Length of the power cord: 200 cm
- Door location: right, interchangeable

Dimensions: (H x W x D) 202 x 65.5 x 84.6 cm

Freezer – PF1

- Category: Freezer for professional gastronomy
- Consumption: 2953 kWh/year
- Power input: 2,3 A/420 W
- Gross volume: 650 l
- Cooling method: Dynamic
- Ambient operating temperature: +10 °C to +40 °C
- For GN 2/1, digital indicator with alarms - HACCP

Other features

- Gross weight: 140 kg
- Net weight: 120 kg
- Stainless steel casing and interior
- Cooling system: Dynamic
- Defrosting method: Automatic
- Control type: electronic control
- Temperature indicator: outer digital
- Operation indicator: yes
- Fault indicator: optical and acoustic
- Shelf material: GN 2/1 grates with plastic finish
- Number of shelves: 3
- of which height-adjustable: 3
- Ventilator: yes
- Temperature range: -15 °C to -22 °C
- Refrigerant: R290
- Handle: Integrated handle
- Adjustable feet: 4
- Feet material: stainless steel
- Lock: yes
- Self-closing doors: yes
- Voltage: 220-230 V
- Length of the power cord: 200 cm
- Door location: right, interchangeable

Dimensions: (H x W x D) 202 x 65.5 x 84.6 cm



Accessories



Wool basket



Enamel baking tray



Universal pan



Combination grid



3-stage telescopic extensions (R+L)
(Illustrative image, delivery without grid and trays)



1-stage telescopic extensions (R+L)
(Illustrative image)



Set for condensate drain for T1



SK1 - connecting piece for washing machine and dryer with an extension



SK2 - connecting piece for washing machine and dryer without an extension

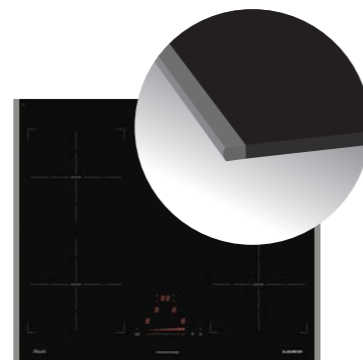

Decorative side bar for hobs

Illustrations for built-in installation

All dimensions are stated in mm

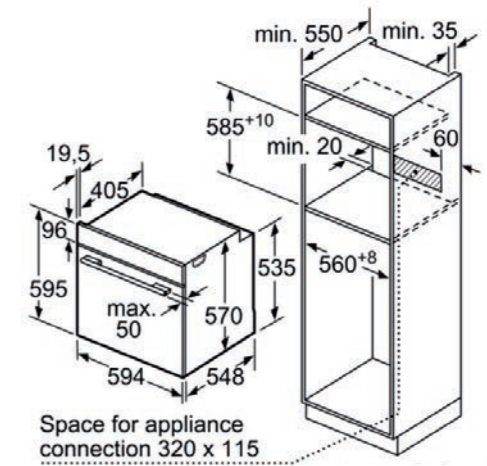
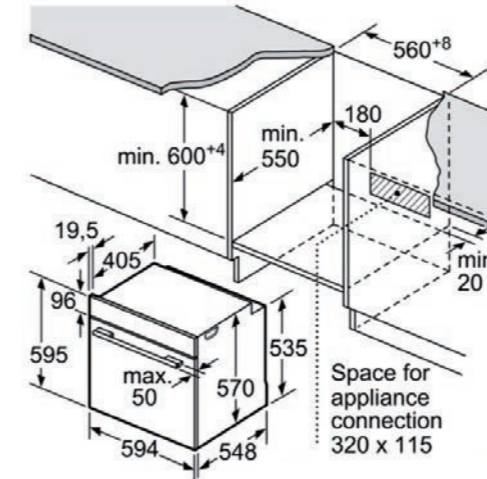

Built-in installation for models: B3

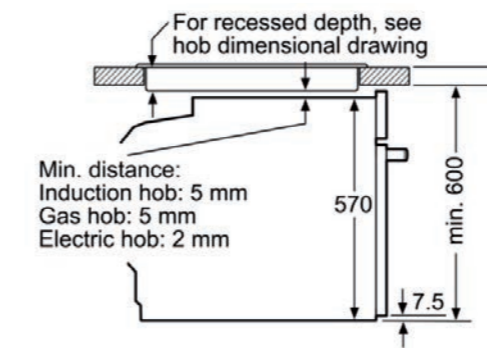

Built-in installation for models: B3 with a hob

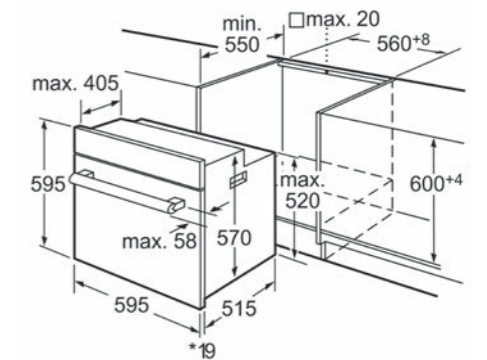

Built-in installation for models: B1, B2

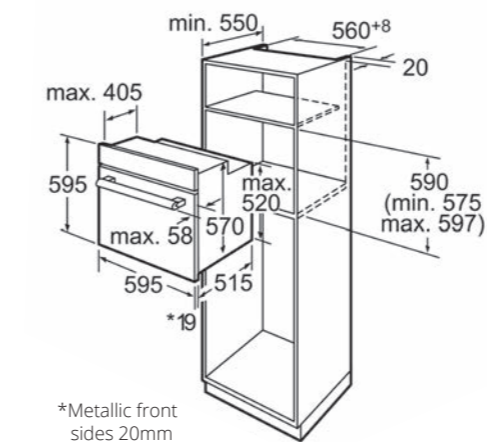

*Metallic front sides 20mm

Built-in installation for models: B1, B2

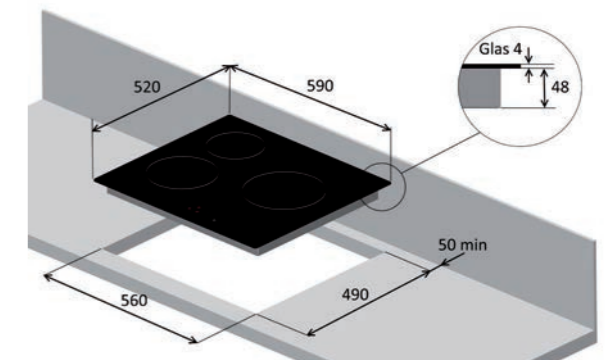

Built-in installation for models: H1, H2

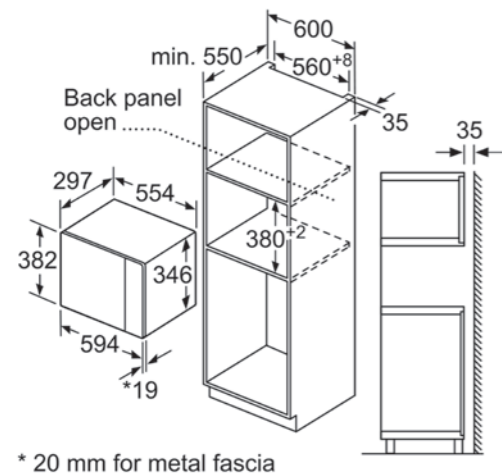

Built-in installation for model: M1

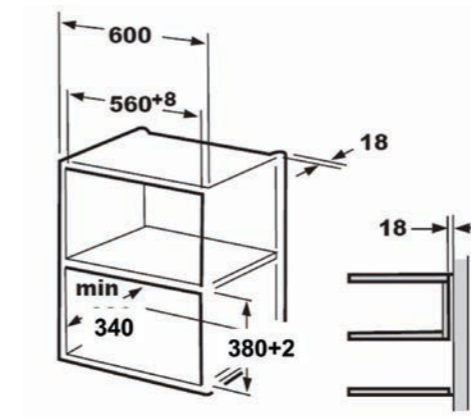
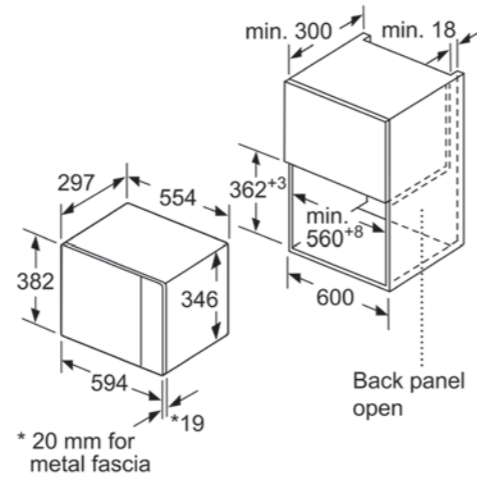

Built-in installation for model: M5

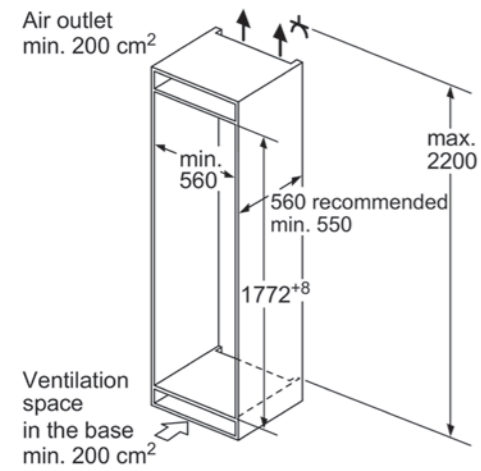
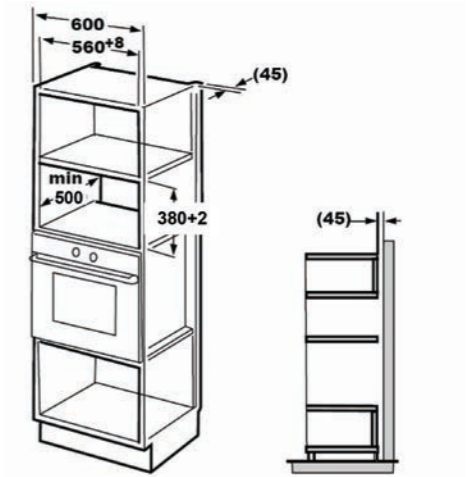

Built-in installation for model: C3

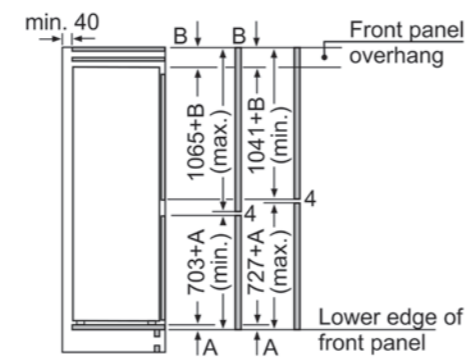

The specified unit door dimensions are valid for a door gap of 4 mm.

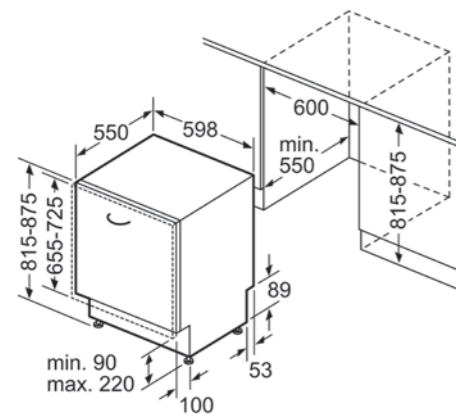

Built-in installation for model: D1

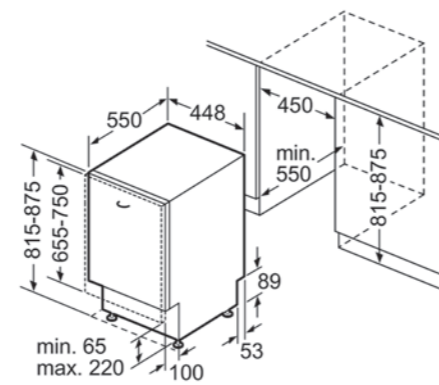

Built-in installation for model: D2