

④ LAST FITTING STEPS

Fit the spacer sleeves in the centre of the diffuser. Put the long threaded screw through the holes in the middle of the diffuser and the sleeve and screw it into the plastic threads.

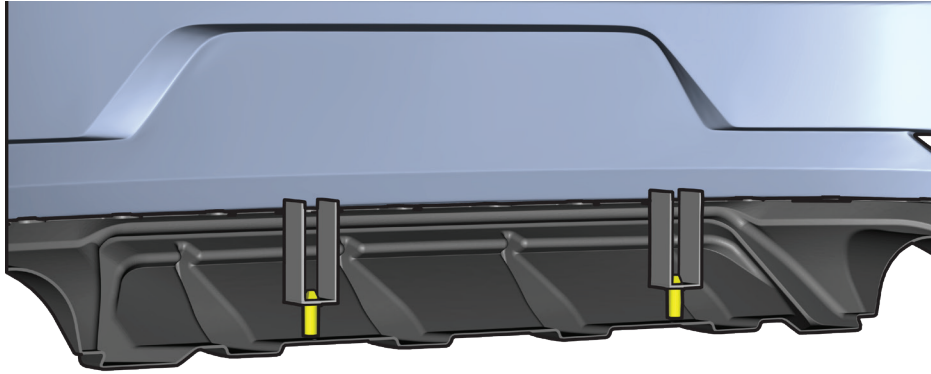

Please note that you have to remove the original plastic parts on the inside of the bumper (left & right). Drill a new hole on the underside of the bumper (marked blue) with a 7mm drill bit. As a last step you can now attach the plastic rivets through the drilled holes.

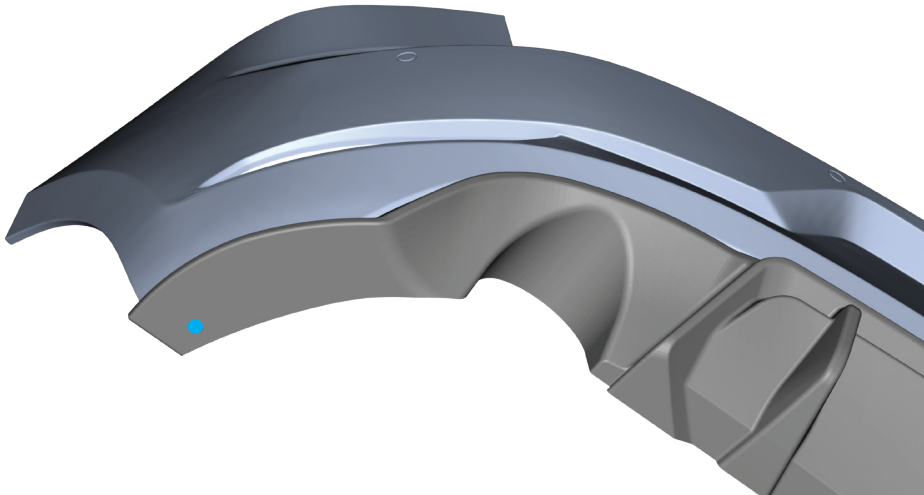

Done! We wish you a lot of fun with your new diffuser!
Tuning is not just a passion, it's a lifestyle!

Enjoy it!

ZAERO

D E S I G N

EVO-1 DIFFUSER FOR VW GOLF MK 7.5 GTI

Installation Manual



WWW.ZAERO-DESIGN.COM

EVO-1 DIFFUSER FOR VW GOLF MK 7.5 GTI

DISASSEMBLY OF THE ORIGINAL DIFFUSER

Please remove the original Diffuser. The easiest way to release the anchoring clips from the bumper is to press them down on the inside of the bumper, so that the clip does not lock. Please note the fastening points below the bumper.

①

Anchored correctly

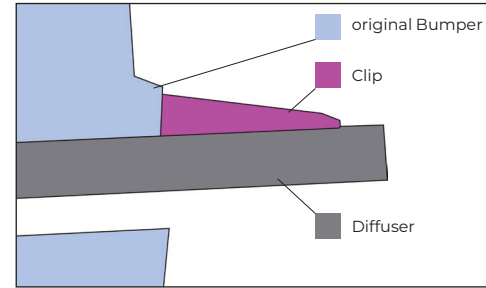

Not anchored correctly

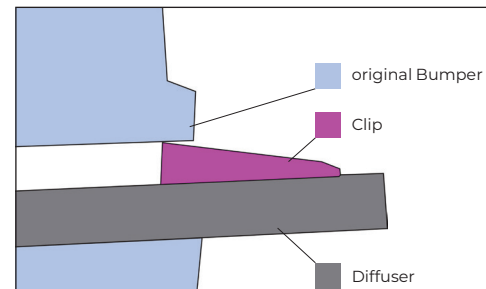

② REMOVING PROTECTIVE FILM

Please peel off the protective film slightly at the edges so that you can remove the protective film more easily when mounted.



③

INSTALLATION OF THE DIFFUSER

As first step after the original diffuser was dismantled, insert the plastic threads (marked yellow) into the original steel holders first.

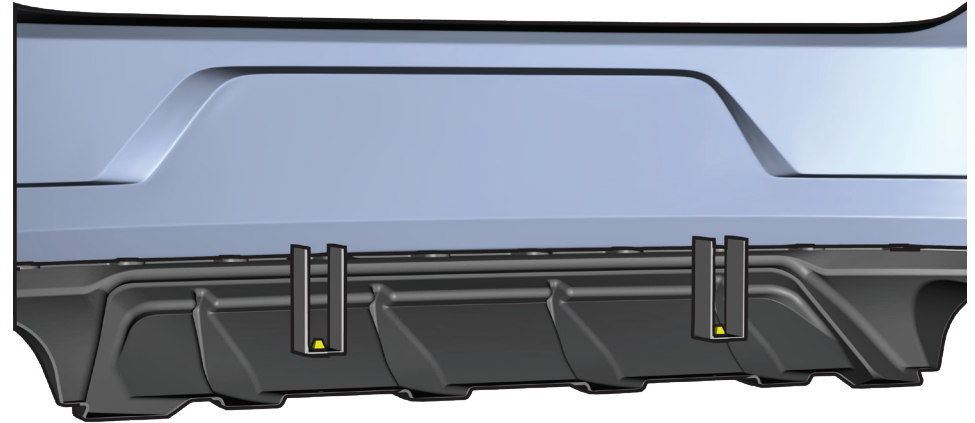

You can attach our diffuser now. Make sure that all tabs are inserted correctly in the original bumper.

Gently push the diffuser onto the bumper to achieve the correct position. As the bumpers are often very soft in the middle and give way, make sure that you can hold against them from the inside if necessary.

The clips must now anchor with the bumper.

