

# SDS05W SDH05W SERIES

DC-DC CONVERTER

4:1 ULTRA WIDE INPUT RANGE  
UP TO 5.04 WATTS

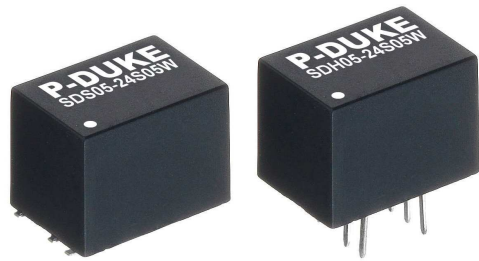

## FEATURES

- ULTRA SMALL SMD AND DIP PACKAGE, 0.52 x 0.36x 0.40 INCH WITH REGULATED
- SMD PACKAGE QUALIFIED FOR LEADFREE REFLOW SOLDER PROCESS ACCORDING IPC J-STD-020D
- NO MINIMUM LOAD REQUIRED
- CONTINUOUS SHORT CIRCUIT PROTECTION
- 1600VDC INPUT TO OUTPUT ISOLATION AND 3000VDC FOR OPTION
- SAFETY MEETS UL60950-1, EN60950-1, & IEC60950-1
- CE MARKED
- COMPLIANT TO RoHS II & REACH

## APPLICATIONS

- WIRELESS NETWORK
- TELECOM/DATACOM
- INDUSTRY CONTROL SYSTEM
- MEASUREMENT EQUIPMENT
- SEMICONDUCTOR EQUIPMENT

3000VDC ISOLATION	1600VDC ISOLATION	REMOTE CONTROL	OCP	SCP
-------------------	-------------------	----------------	-----	-----

## TECHNICAL SPECIFICATION

All specifications are typical at nominal input, full load and 25°C otherwise noted

Model Number	Input Range	Output Voltage	Output Current @Full Load	Input Current @ No Load	Efficiency	Maximum Capacitor Load
	VDC	VDC	mA	mA	%	µF
SDS(H)05-24S3P3W	9 ~ 36	3.3	1000	20	76	4400
SDS(H)05-24S05W	9 ~ 36	5	1000	30	80	2200
SDS(H)05-24S12W	9 ~ 36	12	420	30	83	1220
SDS(H)05-24S15W	9 ~ 36	15	333	30	83	1000
SDS(H)05-24S24W	9 ~ 36	24	210	30	83	470
SDS(H)05-24D05W	9 ~ 36	±5	±500	30	80	±1000
SDS(H)05-24D12W	9 ~ 36	±12	±210	30	83	±680
SDS(H)05-24D15W	9 ~ 36	±15	±168	30	84	±440
SDS(H)05-48S3P3W	18 ~ 75	3.3	1000	10	76	4400
SDS(H)05-48S05W	18 ~ 75	5	1000	12	81	2200
SDS(H)05-48S12W	18 ~ 75	12	420	15	83	1220
SDS(H)05-48S15W	18 ~ 75	15	333	15	83	1000
SDS(H)05-48S24W	18 ~ 75	24	210	15	83	470
SDS(H)05-48D05W	18 ~ 75	±5	±500	15	80	±1000
SDS(H)05-48D12W	18 ~ 75	±12	±210	15	83	±680
SDS(H)05-48D15W	18 ~ 75	±15	±168	15	84	±440

## PART NUMBER STRUCTURE

SDS05 -	48	S	05	W	H
Series Name	Input Voltage (VDC)	Output Quantity	Output Voltage (VDC)	Input Range	Isolation Option
SDS: SMD type	24: 9~36	S: Single	3P3: 3.3	4:1	□: Standard type
SDH: DIP type	48: 18~75		05: 5		1600VDC isolation
			12: 12		H: 3000VDC Isolation
			15: 15		
			24: 24		
		D: Dual	05: ±5		
			12: ±12		
			15: ±15		

**INPUT SPECIFICATIONS**

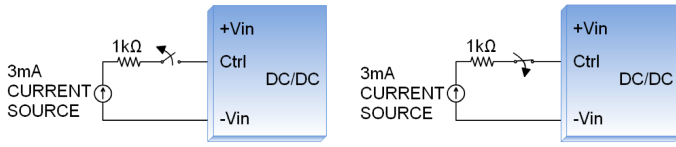
Parameter	Conditions	Min.	Typ.	Max.	Unit
Operating input voltage range	24Vin(nom)	9	24	36	VDC
	48Vin(nom)	18	48	75	
Start up time	Constant resistive load	Power up	5	10	ms
		Remote ON/OFF	5	10	
Input surge voltage	1 second, max.	24Vin(nom)		50	VDC
		48Vin(nom)		100	
Input reflected ripple current <sup>(1)</sup>		24Vin(nom)	20		mAp-p
		48Vin(nom)	15		
Input filter					Capacitor type
Remote ON/OFF	Ctrl pin applied current via 1kΩ	DC-DC ON	Open or high impedance		mA
		DC-DC OFF	2.0	3.0	4.0
		Remote off input current		2.5	mA
	Application circuit	DC-DC ON		DC-DC OFF	
					

**OUTPUT SPECIFICATIONS**

Parameter	Conditions	Min.	Typ.	Max.	Unit	
Voltage accuracy		-1.0		+1.0	%	
Line regulation	Low Line to High Line at Full Load	-0.2		+0.2	%	
Load regulation	No Load to Full Load	Single		+1.0	%	
		Dual		+1.0		
	10% Load to 90% Load	Single	-0.5			+0.5
		Dual	-0.8			+0.8
Cross regulation	Asymmetrical load 25%/100% FL	-5.0		+5.0	%	
Ripple and noise	Measured by 20MHz bandwidth		75		mVp-p	
Temperature coefficient		-0.02		+0.02	%/°C	
Transient response recovery time	25% load step change		500		µs	
Short circuit protection					Continuous, automatic recovery	

**GENERAL SPECIFICATIONS**

Parameter	Conditions	Min.	Typ.	Max.	Unit
Isolation voltage	1 minute	Standard	1600		VDC
		Suffix "H"	3000		
Isolation resistance	500VDC	1			GΩ
Isolation capacitance		Standard Suffix "H"		50	pF
				50	
Switching frequency		100			kHz
Safety meets					UL60950-1 EN60950-1 IEC60950-1
Case material					Non-conductive black plastic
Base material					Non-conductive black plastic
Potting material					Silicone (UL94 V-0)
Weight					2.7g (0.10oz)
MTBF	MIL-HDBK-217F, Full load				2.281 x 10 <sup>6</sup> hrs

**ENVIRONMENTAL SPECIFICATIONS**

Parameter	Conditions	Min.	Typ.	Max.	Unit
Operating ambient temperature	With derating	-40		+105	°C
Storage temperature range		-55		+125	°C
Thermal shock					MIL-STD-810F
Vibration					MIL-STD-810F
Relative humidity					5% to 95% RH
Lead-free reflow solder process					IPC J-STD-020D
Moisture sensitivity level(MSL)					IPC J-STD-033B Level 2

**EMC SPECIFICATIONS**

Parameter	Conditions	Level
EMI (1)	EN55022	Class A, Class B
ESD	EN61000-4-2 Air $\pm 8kV$ Contact $\pm 6kV$	Perf. Criteria A
Radiated immunity	EN61000-4-3 10 V/m	Perf. Criteria A
Fast transient (2)	EN61000-4-4 $\pm 2kV$	Perf. Criteria A
Surge (2)	EN61000-4-5 $\pm 1kV$	Perf. Criteria A
Conducted immunity	EN61000-4-6 10 Vr.m.s	Perf. Criteria A
Power frequency magnetic field	EN61000-4-8 100A/m continuous; 1000A/m 1 second	Perf. Criteria A

**Note:**

- The standard module meet EMI Class A or Class B and input reflected ripple current with external components. For further information, please contact with P-DUKE
- An external input filter capacitor is required if the module has to meet EN61000-4-4, EN61000-4-5. The filter capacitor Power Mate suggest: Nippon chemi-con KY series, 220  $\mu F/100V$ .

**CAUTION:** This power module is not internally fused. An input line fuse must always be used.

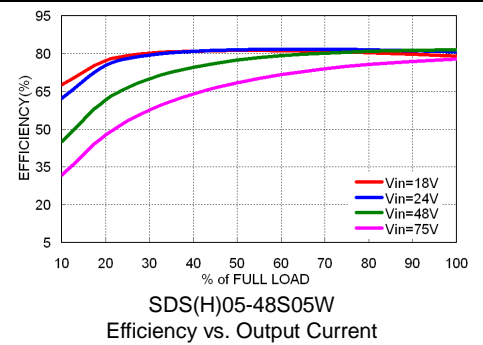
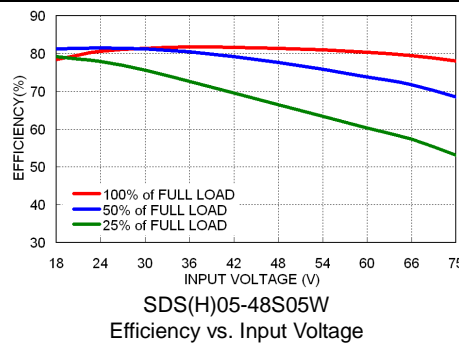
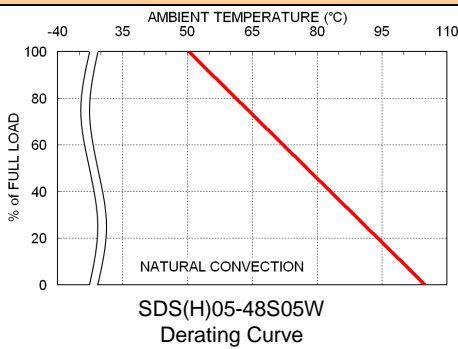
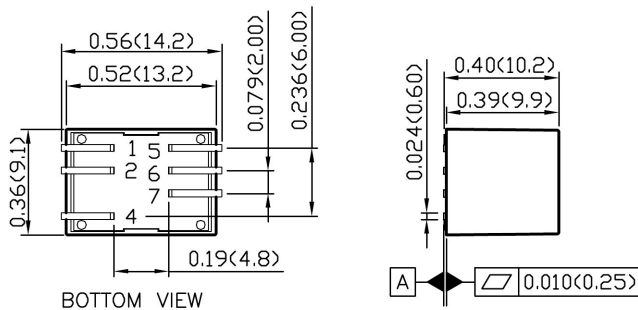
**CHARACTERISTIC CURVE**

**MECHANICAL DRAWING**
**SDS05W: SMD TYPE**

**PIN CONNECTION**

PIN	SINGLE	DUAL
1	+Vin	+Vin
2	-Vin	-Vin
4	Ctrl	Ctrl
5	NC	-Vout
6	-Vout	Common
7	+Vout	+Vout

- All dimensions in inch (mm)
- Tolerance :x.xxx $\pm 0.02$  (x.x $\pm 0.5$ )  
x.xxx $\pm 0.01$  (x.xx $\pm 0.25$ )
- Pin pitch tolerance  $\pm 0.01$  (0.25)
- Pin dimension tolerance  $\pm 0.004$  (0.1)

**SDH05W: DIP TYPE**
