

QAE150W SERIES

QUARTER-BRICK DC-DC CONVERTER

4:1 ULTRA WIDE INPUT RANGE
UP TO 132Watts



FEATURES

- NO MINIMUM LOAD REQUIRED
- LOW STANDBY POWER CONSUMPTION
- 2250VDC INPUT TO OUTPUT BASIC INSULATION
- SAFETY MEETS UL60950-1, EN60950-1, & IEC60950-1
- COMPLIANCE TO EN50155 AND EN45545-2 RAILWAY STANDARD
- CE MARKED
- COMPLIANT TO RoHS II & REACH

APPLICATIONS

- RAILWAY SYSTEM
- WIRELESS NETWORK
- TELECOM/DATACOM
- INDUSTRY CONTROL SYSTEM
- DISTRIBUTED POWER ARCHITECTURES
- SEMICONDUCTOR EQUIPMENT

2250VDC ISOLATION	REMOTE CONTROL	UVP	OCP	SCP	OVP	OTP	LOW STANDBY POWER
-------------------	----------------	-----	-----	-----	-----	-----	-------------------

TECHNICAL SPECIFICATION

All specifications are typical at nominal input, full load and 25°C otherwise noted

Model Number	Input Range	Output Voltage	Output Current @Full Load	Input Current @ No Load	Efficiency	Maximum Capacitor Load
	VDC	VDC	A	mA	%	µF
QAE150-24S3P3W	8.5 ~ 36	3.3	30	25	88	91000
QAE150-24S05W	8.5 ~ 36	5	24	25	89	48000
QAE150-24S12W	8.5 ~ 36	12	10	25	88	8300
QAE150-24S15W	8.5 ~ 36	15	8	25	89	5300
QAE150-24S24W	8.5 ~ 36	24	5	25	88	2100
QAE150-24S30W	8.5 ~ 36	30	4	25	89	1300
QAE150-24S48W	8.5 ~ 36	48	2.5	25	88	520
QAE150-48S3P3W	16.5 ~ 75	3.3	30	15	88	91000
QAE150-48S05W	16.5 ~ 75	5	24	15	89	48000
QAE150-48S12W	16.5 ~ 75	12	10	15	89	8300
QAE150-48S15W	16.5 ~ 75	15	8	15	90	5300
QAE150-48S24W	16.5 ~ 75	24	5	15	90	2100
QAE150-48S30W	16.5 ~ 75	30	4	15	90	1300
QAE150-48S48W	16.5 ~ 75	48	2.5	15	90	520
QAE150-110S3P3W	40 ~ 160	3.3	30	8	88	91000
QAE150-110S05W	40 ~ 160	5	24	8	89	48000
QAE150-110S12W	40 ~ 160	12	11	8	88	9170
QAE150-110S15W	40 ~ 160	15	8.6	8	89	5730
QAE150-110S24W	40 ~ 160	24	5.5	8	89	2290
QAE150-110S30W	40 ~ 160	30	4.4	8	89	1470
QAE150-110S48W	40 ~ 160	48	2.7	8	89	560

PART NUMBER STRUCTURE

QAE150	-	48	S	05	W	-	P	HS
Series Name		Input Voltage (VDC)	Output Quantity	Output Voltage (VDC)	Input Range		Ctrl and Pin Options	Assembly Option
		24:8.5~36 48:16.5~75 110:40~160	S:Single	3P3:3.3 05:5 12:12 15:15 24:24 30:30 48:48	4:1		□:Negative logic P:Positive logic	□:None HS:H=0.24" Horizontal, 7G-0029B-F HS1:H=0.5" Horizontal, 7G-0030B-F HS2:H=0.24" Vertical, 7G-0031B-F HS3:H=0.5" Vertical, 7G-0032B-F TH:Through hole (No thread) ⁽¹⁾

(1) The module can't equip Heat-sink with TH option.

INPUT SPECIFICATIONS

Parameter	Conditions	Min.	Typ.	Max.	Unit	
Operating input voltage range	24Vin(nom)	8.5	24	36	VDC	
	48Vin(nom)	16.5	48	75		
	110Vin(nom)	40	110	160		
Start-up voltage	24Vin(nom)			9	VDC	
	48Vin(nom)			18		
	110Vin(nom)			43		
Shutdown voltage	24Vin(nom)	7.3		8.1	VDC	
	48Vin(nom)	15.5		16.3		
	110Vin(nom)	33.0		36.0		
Start up time	Constant resistive load	Power up	75	100	ms	
		Remote ON/OFF	75	100		
Input surge voltage	1 second, max.	24Vin(nom)		50	VDC	
		48Vin(nom)		100		
		110Vin(nom)		185		
Input filter ⁽¹⁾		Pi type				
Remote ON/OFF	Referred to -Vin pin	Negative logic DC-DC ON		Short or 0 ~ 1.2VDC		
		(Standard) DC-DC OFF		Open or 3 ~ 12 VDC		
		Positive logic DC-DC ON		Open or 3 ~ 12 VDC		
		(Option) DC-DC OFF		Short or 0 ~ 1.2VDC		
		Input current of Ctrl pin	-0.5	1	mA	
		Remote off input current	3		mA	

OUTPUT SPECIFICATIONS

Parameter	Conditions	Min.	Typ.	Max.	Unit
Voltage accuracy		-1.0		+1.0	%
Line regulation	Low Line to High Line at Full Load	-0.1		+0.1	%
Load regulation	No Load to Full Load	3.3 & 5Vout		+0.2	%
		Others		+0.1	
Voltage adjustability	Maximum output deviation is inclusive of remote sense	-20		+10	%
Remote sense	% of Vout(nom). If remote sense is not being used, sense pins should connect to the output pins with the same polarity.			10	%
Ripple and noise	Measured by 20MHz bandwidth				mVp-p
	With a 22µF/25V X7R MLCC	3.3Vout, 5Vout	75		
	With a 22µF/25V X7R MLCC	12Vout, 15Vout	100		
	With a 4.7µF/50V X7R MLCC	24Vout, 30Vout	200		
	With a 2.2µF/100V X7R MLCC	48Vout	300		
Temperature coefficient		-0.02		+0.02	%/°C
Transient response recovery time	25% load step change		250		µs
Over voltage protection	% of Vout(nom); Hiccup mode	115		130	%
Over load protection	% of Iout rated; Hiccup mode	110		140	%
Short circuit protection		Continuous, automatic recovery			

GENERAL SPECIFICATIONS

Parameter	Conditions	Min.	Typ.	Max.	Unit
Isolation voltage	1 minute (Basic insulation)	Input to Output	2250		VDC
		Input (Output) to Base-Plate	2250		
Isolation resistance	500VDC	1			GΩ
Isolation capacitance				1500	pF
Switching frequency		270	300	330	kHz
Safety meets				UL60950-1 EN60950-1 IEC60950-1 EN50155	
Case material		Aluminum base-plate with plastic case			
Potting material		Silicone (UL94 V-0)			
Weight		64g (2.26oz)			
MTBF	MIL-HDBK-217F, Full load	3.684 x 10 ⁵ hrs			

ENVIRONMENTAL SPECIFICATIONS

Parameter	Conditions	Min.	Typ.	Max.	Unit
Operating base-plate temperature		-40		+100	°C
Over temperature protection			+110		°C
Storage temperature range		-55		+125	°C
Thermal impedance (2)	Without Heat-sink Vertical direction by natural convection (20LFM)		9 2.8 7.1 5.5		°C/W
Thermal shock					MIL-STD-810F
Shock					EN61373, MIL-STD-810F
Vibration					EN61373, MIL-STD-810F
Relative humidity					5% to 95% RH

Advice Electronics Ltd

EMC SPECIFICATIONS

Advice Building, 16 Atir Yeda St., Kfar Saba, 4464321, Israel • Tel: +972-3-9000910 • sales@advice.co.il • www.advice.co.il

Parameter	Conditions	Level
EMI (3)	EN55011, EN55022	Class A Class B
ESD	EN61000-4-2 Air ± 8kV Contact ± 6kV	Perf. Criteria A
Radiated immunity	EN61000-4-3 20 V/m	Perf. Criteria A
Fast transient (4)	EN61000-4-4 ± 2kV	Perf. Criteria A
Surge (4)	EN61000-4-5 EN55024:±2kV EN50155:±2kV	Perf. Criteria A
Conducted immunity	EN61000-4-6 10 Vr.m.s	Perf. Criteria A
Power frequency magnetic field	EN61000-4-8 100A/m continuous; 1000A/m 1 second	Perf. Criteria A

Note:

- Input source impedance: The power module will operate as specifications without external components, assuming that the source voltage has a very low impedance and reasonable input voltage regulation. Highly inductive source impedances can affect the stability of the power module. Since real-world voltage source has finite impedance, performance can be improved by adding external filter capacitor.
The QAE150-24SXXW and QAE150-48SXXW recommended Nippon Chemi-con KY series, 100µF/100V.
The QAE150-110SXXW recommended Ruby-con BXF series, 39µF/200V.
- The heat-sink is optional and P/N: 7G-0029A-F, 7G-0030A-F, 7G-0031A-F, 7G-0032A-F. Please refer to heat-sink selection guide.
- The standard module meets EMI Class A or Class B with external components. For further information, please contact with P-DUKE.
- An external input filter capacitor is required if the module has to meet EN61000-4-4, EN61000-4-5.
The QAE150-24SXXW and QAE150-48SXXW recommended 2 pcs of aluminum electrolytic capacitor (Nippon chemi-con KY series, 220µF/100V) to connect in parallel.
The QAE150-110SXXW recommended 3 pcs of aluminum electrolytic capacitor (Ruby-con BXF series, 100µF/250V) to connect in parallel.
- BASE-PLATE GROUNDING: When connect two screw bolts to shield plane, the EMI could be reduced.

CAUTION: This power module is not internally fused. An input line fuse must always be used.

CHARACTERISTIC CURVE

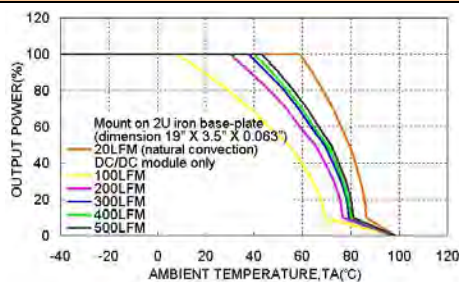

QAE150-24S05W Derating Curve

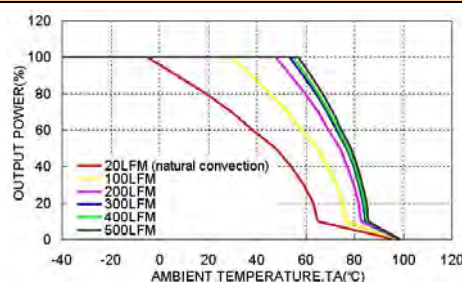

QAE150-24S05W Derating Curve
With 0.24" Height Heat-sink

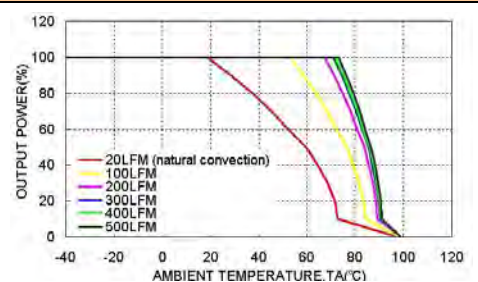

QAE150-24S05W Derating Curve
With 0.5" Height Heat-sink

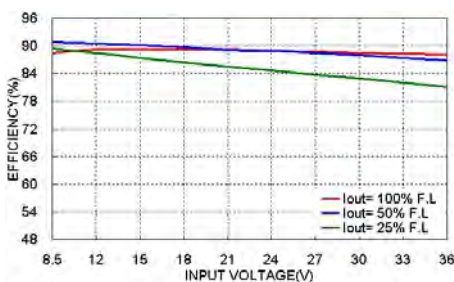

QAE150-24S05W Efficiency vs. Input Voltage

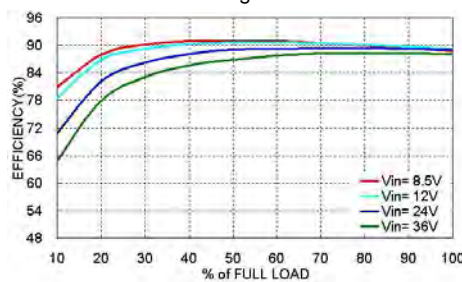

QAE150-24S05W Efficiency vs. Output Load

Advice Electronics Ltd

MECHANICAL DRAWING

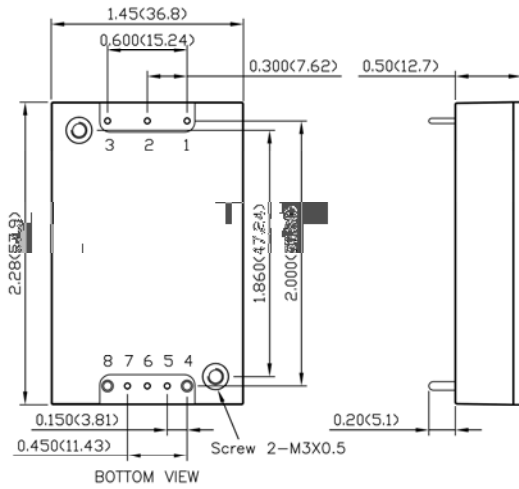

PIN CONNECTION

PIN	DEFINE	DIAMETER
1	- Vin	0.04 Inch
2	Ctrl	0.04 Inch
3	+ Vin	0.04 Inch
4	- Vout	0.06 Inch
5	- Sense	0.04 Inch
6	Trim	0.04 Inch
7	+ Sense	0.04 Inch
8	+ Vout	0.06 Inch

EXTERNAL OUTPUT TRIMMING

Output can be externally trimmed by using the method shown below.

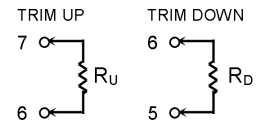

1. All dimensions in inch (mm)
2. Tolerance :x.xx±0.02 (x.x±0.5)
x.xxx±0.01 (x.xx±0.25)
3. Pin pitch tolerance ±0.01 (0.25)
4. Pin dimension tolerance ±0.004(0.1)
5. The screw locked torque:
MAX 3.5kgf-cm (0.34N-m)

$$R_U = \left(\frac{5.11V_{OUT}(100 + \Delta\%)}{1.225\Delta\%} - \frac{(511 + 10.22\Delta\%)}{\Delta\%} \right) k\Omega$$

$$R_D = \left(\frac{511}{\Delta\%} - 10.22 \right) k\Omega$$

HEAT-SINK TYPE OPTIONS

7G-0029B-F

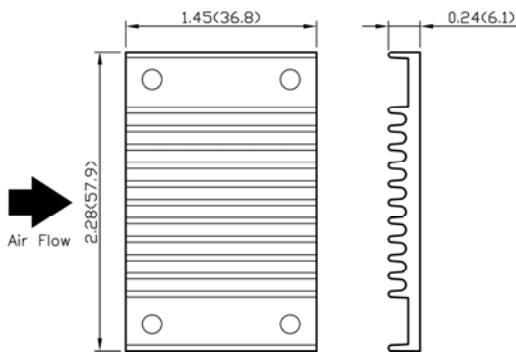

7G-0030B-F

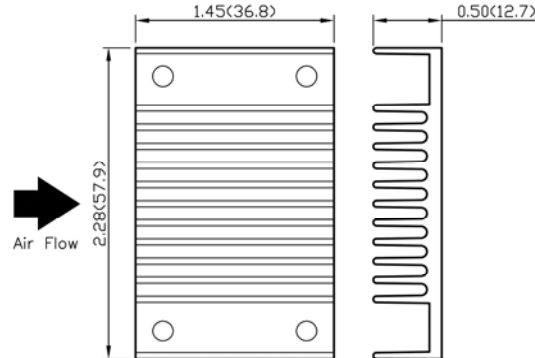

7G-0031B-F

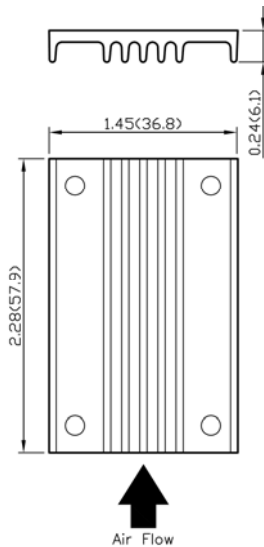

7G-0032B-F

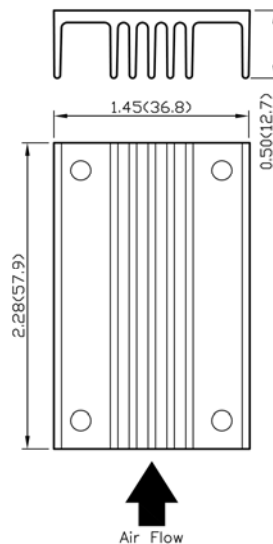

1. All dimensions in inch (mm)
2. Tolerance :x.xx±0.02 (x.x±0.5)